

(12) **UK Patent Application** (19) **GB** (11) **2 186 684** (13) **A**

(43) Application published 19 Aug 1987

(21) Application No **8626443**

(22) Date of filing **5 Nov 1986**

(30) Priority data

(31) **8530040**
8610321

(32) **5 Dec 1985**
28 Apr 1986

(33) **GB**

(51) INT CL⁴

G01N 21/03 21/05 21/51 21/53

(52) Domestic classification (Edition I):

G1A D10 D4 DM G10 G17 G1 G2 G3 G7 P10 P17 P9 R7
S10 S12 S3 S5 T14 T22 T2 T8 T9
U1S 1262 1457 G1A

(71) Applicant

City of London Polytechnic

(Incorporated in United Kingdom)

117-119 Houndsditch, London EC3A 7BU

(56) Documents cited

GB A 2141224 **GB 1588862** **US 4105334**
GB A 2120784 **GB 1524041** **WO A1 84/02396**
GB A 2001751 **EP A2 0157310**

(58) Field of search

G1A
Selected US specifications from IPC sub-class G01N

(72) Inventors

Dr G. H. Meeten
Peter John Molloy

(74) Agent and/or Address for Service

Carpmaels & Ransford,
43 Bloomsbury Square, London WC1A 2RA

(54) **Flocculation monitor**

(57) A flocculation monitor which makes use of shearing force applied to a dispersion of free or discrete colloidal particles to distinguish between particles in their flocculated and non-flocculated states.

White light from a tungsten-halogen lamp 1 run from a stabilised power supply is focussed approximately by a lens 2 onto the influx bundle 4 of a bifurcated optical fibre bundle. The incident light can be wavelength-selected by a variable-wavelength interference filter 3 to give a maximum reflectance change according to the particular type of dispersion being measured. The back-scattering of the dispersion 13 is measured by the light entering the efflux bundle 5. This light is then detected by the silicon photodiode 10, and the optical signal is processed and displayed by the display unit 11. The dispersion 13 is held in a cell 6 with an optically-absorbing base 7. This cell is rotatable by stepping motor 9 via shaft 8, either continuously, or in steps in one direction, or in steps in alternate directions. These then give a continuous shear, or time-dependent shears, respectively. The mode of shear, the shear rate and the angle of shear are controlled by the motor control logic 12. A flow-through cell may alternatively be used, and the shear may be varied by a variable speed pump or a periodically actuated valve, instead of using rotation.

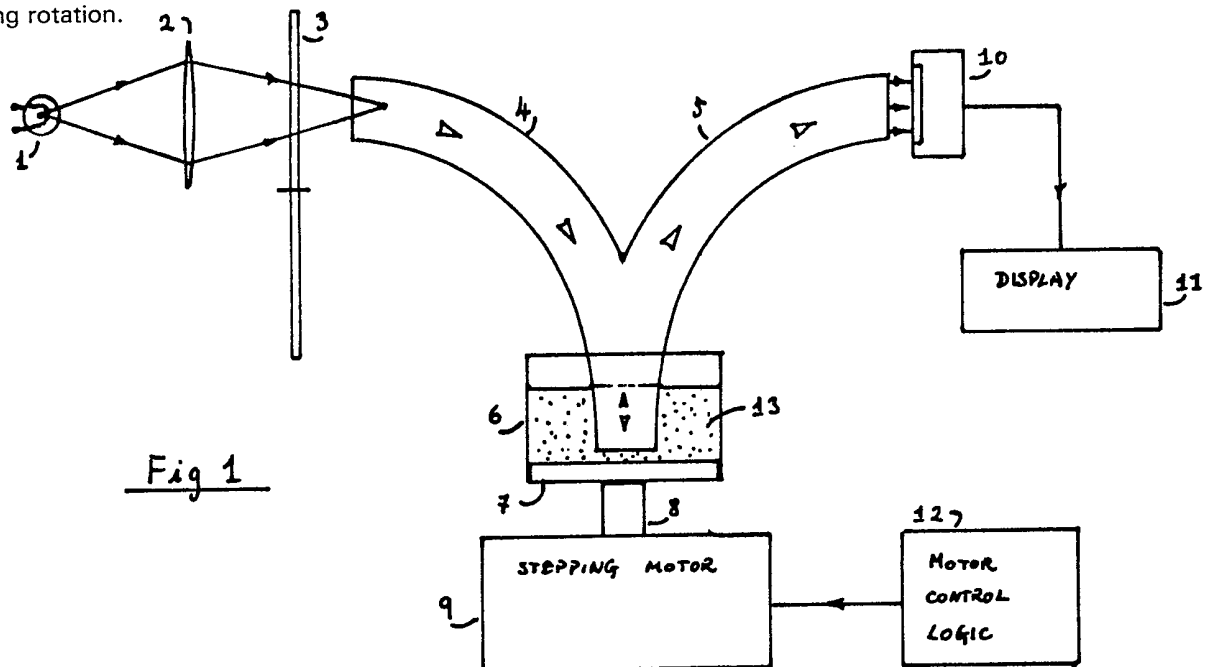

GB 2 186 684 A

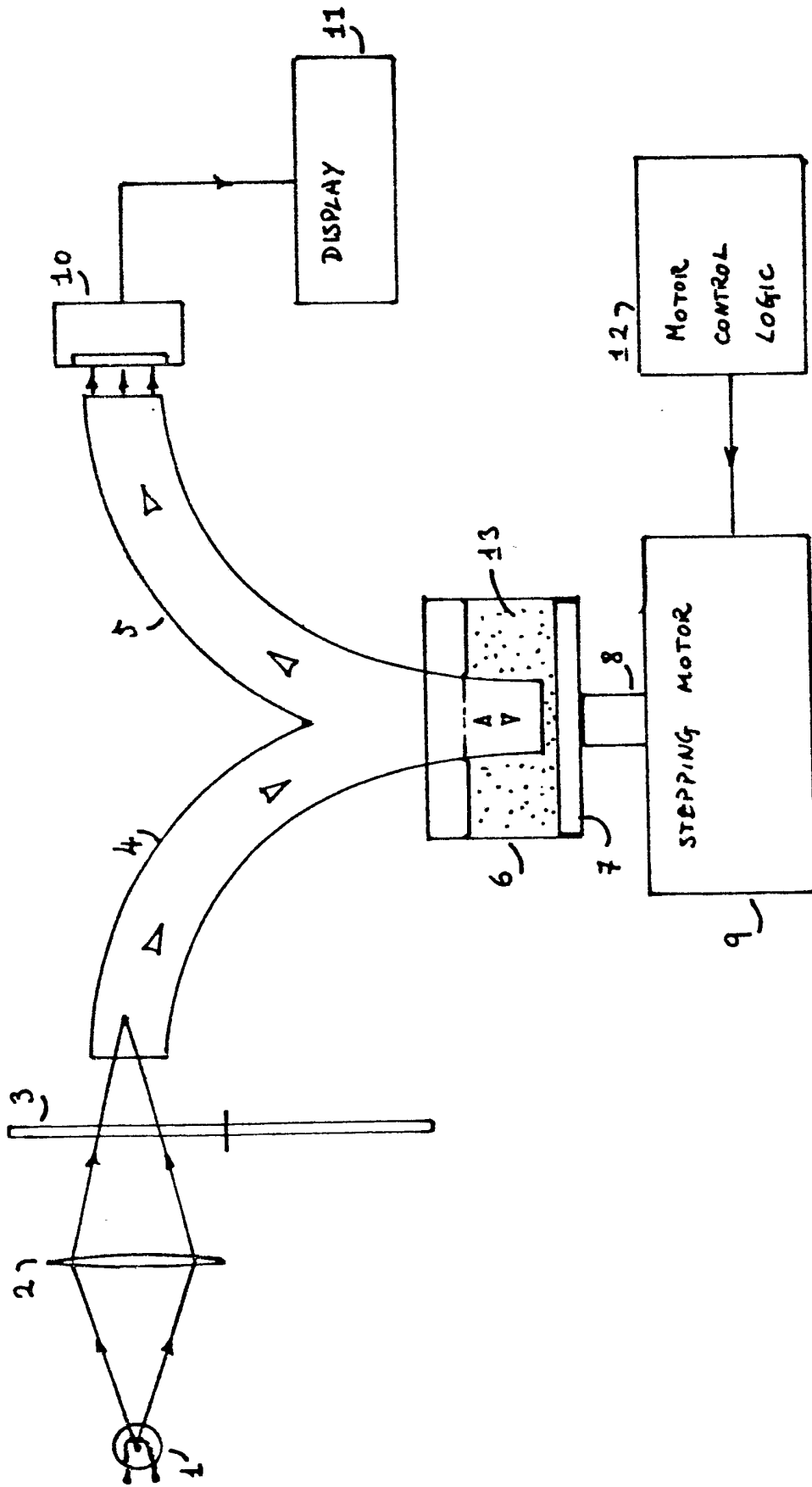

Fig 1

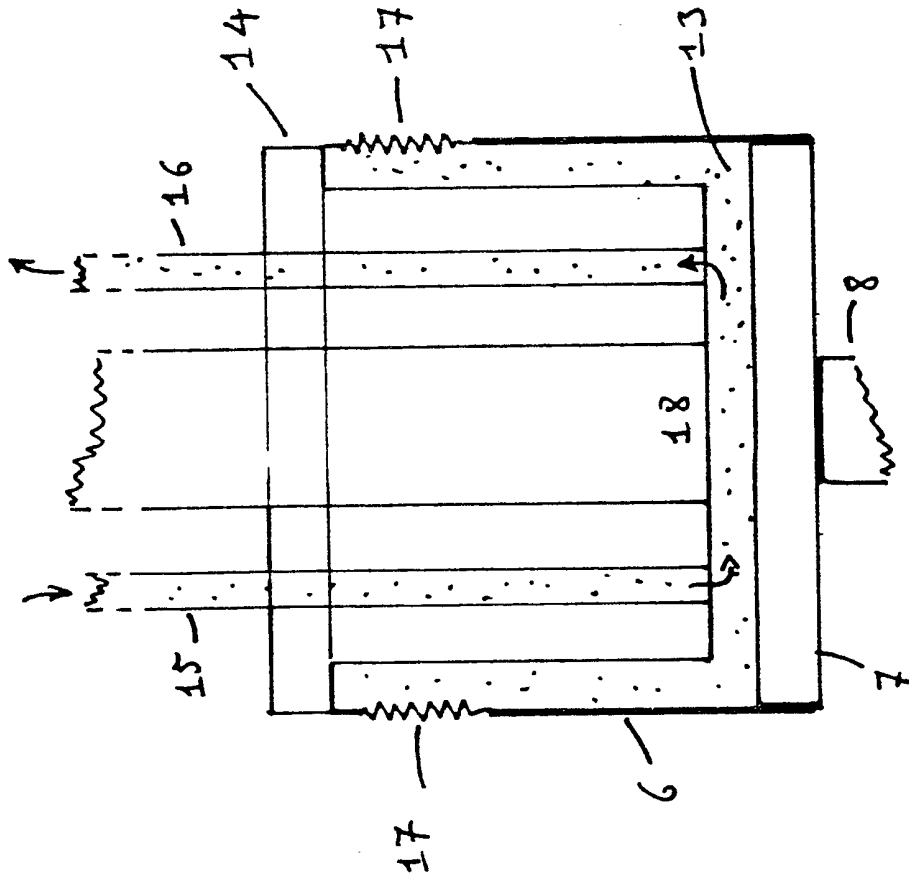
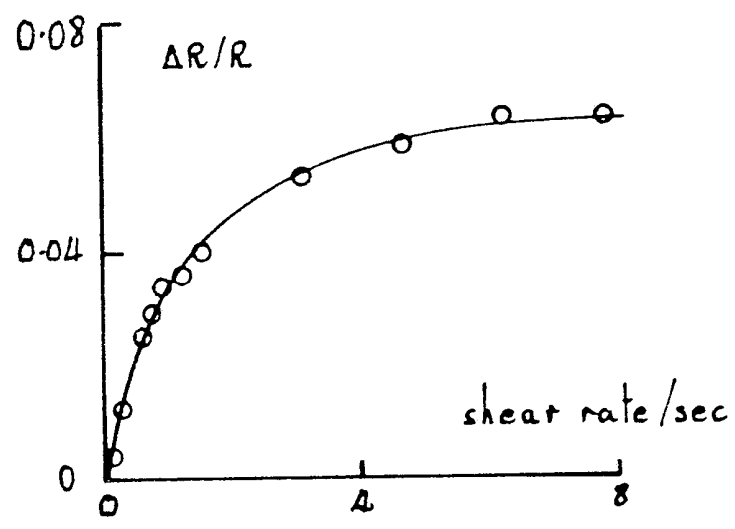
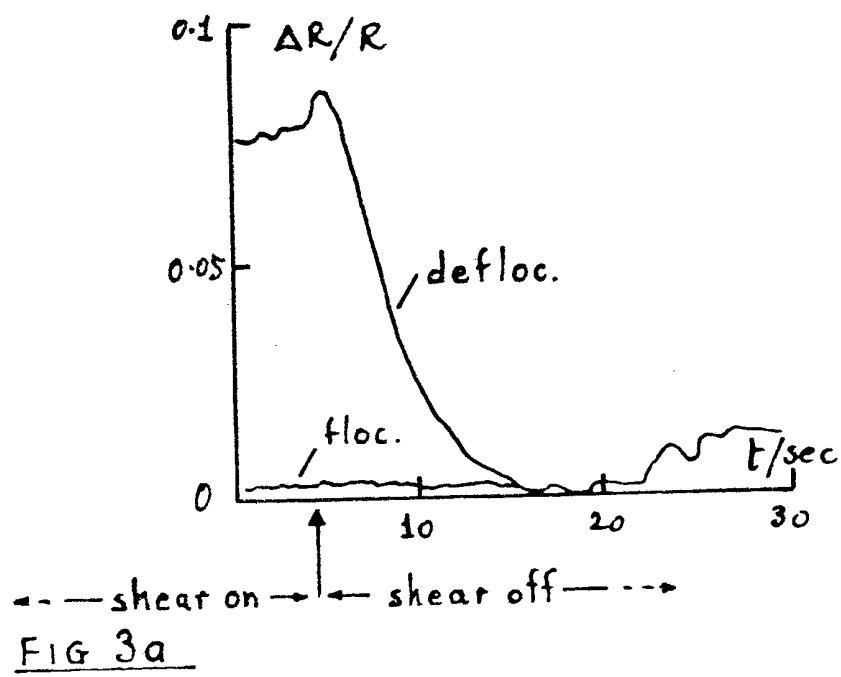

FIG 2



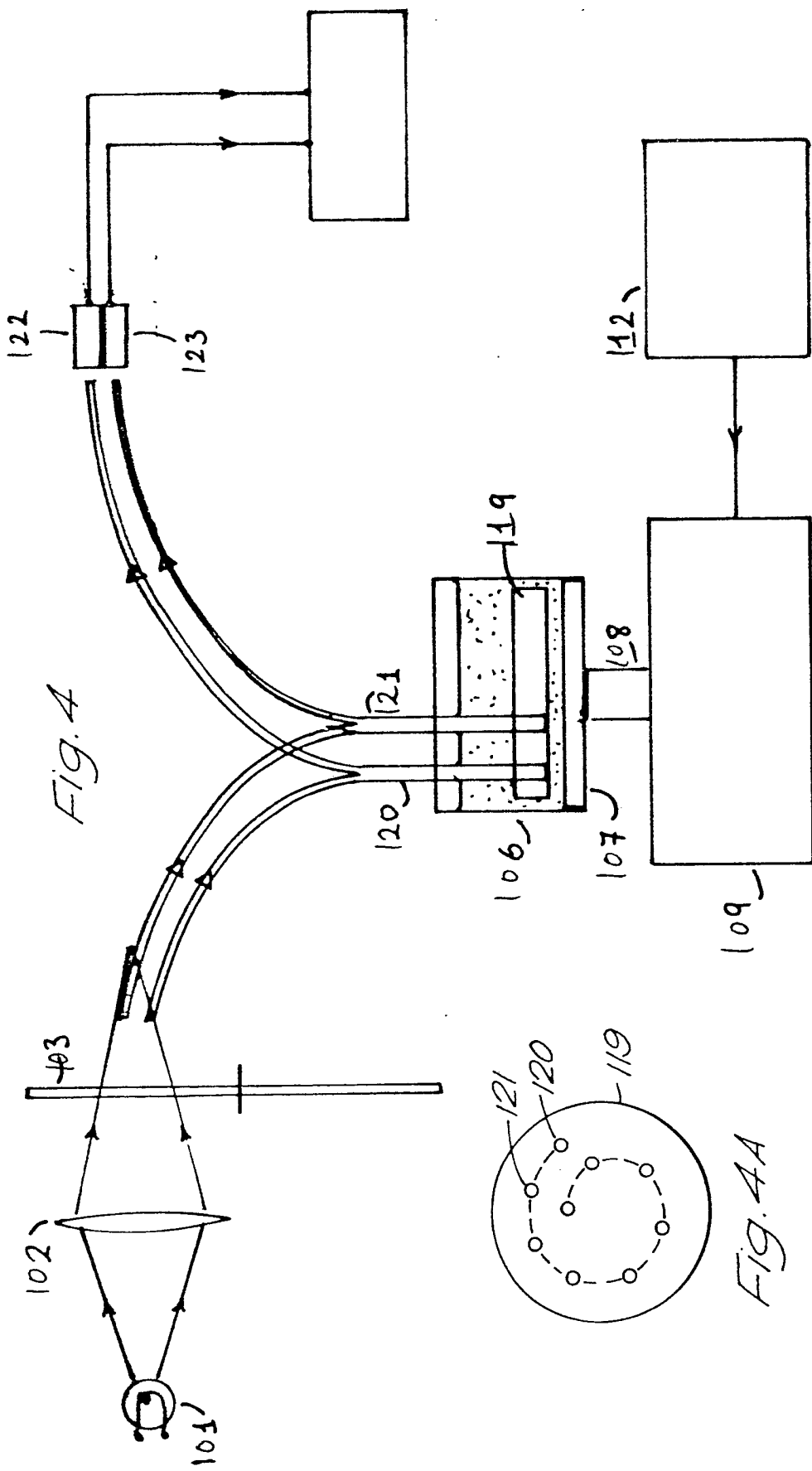

Fig. 4

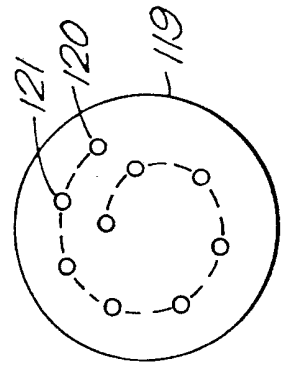

FIG. 4A

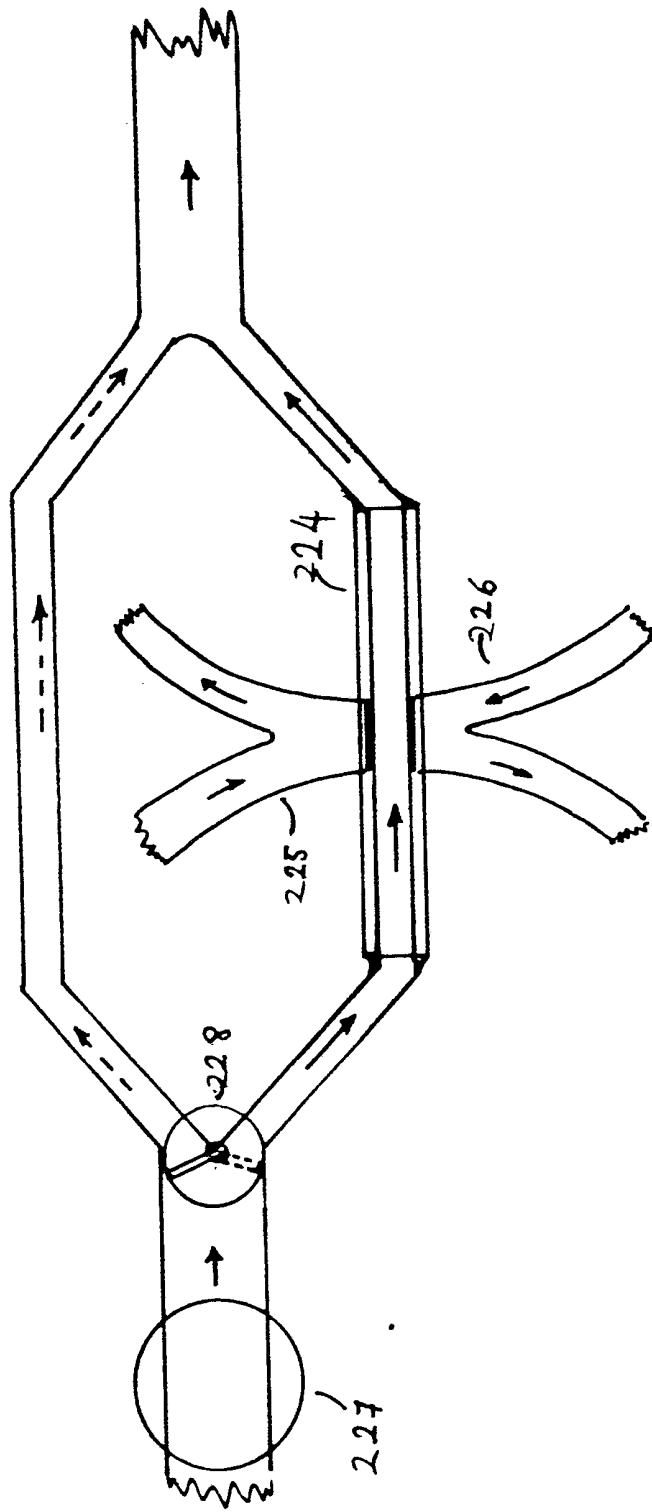

FIG 5

SPECIFICATION

Flocculation monitor

- 5 This invention relates to a flocculation monitor that is to say a device for distinguishing between particles in their flocculated and non-flocculated states. 5
- In accordance with the present invention there is a flocculation monitor comprising a vessel or cell adapted to contain a dispersion of free or discrete colloidal particles, means for introducing incident light into the dispersion and measuring changes in the recovered light, and means for
- 10 subjecting the dispersion of colloidal particles to a shearing force. The shearing force may be applied, for instance either by rotating the vessel continuously or in steps in one direction or in alternate directions, or by causing the dispersion to flow. 10
- Preferably the means for introducing incident light comprises a source of incoherent or diffuse light. The means for introducing incident light and recovering scattered light may comprise
- 15 incoherent optical fibres preferably in bundles and the bundles may extend into the vessel so that in use they enter the dispersion. 15
- The incident light may be passed through a variable wavelength interference filter to enable a maximum change of recovered light to be achieved for the particular dispersion which is to be measured.
- 20 The vessel may be rotated continuously or in steps by an electrical stepping motor which may be controlled by a logic circuit. 20
- Alternatively flow may be altered by pumps or valves.
- A shear-optical system embodying the invention monitors the anisotropy of aggregates in colloidal dispersions and therefore monitors the flocculation process of colloidal particles within a
- 25 dispersion. 25
- When a suspension of free or discrete colloidal particles is sheared there is usually a change in the optical diffuse reflectance and the collimated and diffuse transmittance of the dispersion. This change usually arises from the non-random orientation induced by the shear on the particles. This is due to the action of the shear on the structure of the dispersion. When the
- 30 particles are flocculated there is no similar change in the transmittance and reflectance. This is thought to be due to the mode of flocculation which produces optically isotropic particle aggregates or because the particles are no longer free to orient in the shear field. 30
- The shear-optical flocculation monitor is therefore able to monitor the flocculated and non-flocculated states and intermediate states of flocculation.
- 35 The act of shearing a dispersion of free or discrete colloidal particles is usually accompanied by a change in the backward or forward scattering of the dispersion. This change usually arises from the non-random orientation, induced by the shear, of non-spherical particles. Generally, it occurs due to the effect of the shear on the structure of the dispersion. When the particles are flocculated they are no longer free to orientate in the shear flow and so the act of shear causes
- 40 no scattering changes. The shear-optical flocculation monitor is thus able to distinguish between the flocculated and non-flocculated states, and intermediate states of flocculation if it is properly calibrated. 40
- In the accompanying drawings:-
- Figure 1* is a diagrammatic representation of an apparatus embodying the present invention;
- 45 *Figure 2* shows again diagrammatically, a more practical version of the monitor; 45
- Figure 3a* illustrates graphically experimental results for a flocculated and a deflocculated clay dispersion;
- Figure 3b* is a graph in which relative change in diffuse reflectance is plotted against the average velocity of a cell containing the dispersion, for a deflocculated dispersion;
- 50 *Figure 4* shows diagrammatically a second embodiment of this invention in the form of a monitor capable of measuring the explicit shear-rate dependence of the back scattering; 50
- Figure 4A* shows the spiral disposition of optical bundles employed in Fig. 4; and
- Figure 5* shows diagrammatically a third embodiment of the invention in the form of a monitor in which shear is generated by flowing the dispersion through a parallel-sided flow cell.
- 55 White light from a tungsten-halogen lamp 1 run from stabilised power supply is focused approximately by a lens 2 onto the influx bundle 4 of a bifurcated optical fibre bundle. The incident light can be wavelength-selected by a variable-wavelength interference filter 3 to give a maximum reflectance change according to the particular type of dispersion being measured. The back-scattering of the dispersion 13 is measured by the light entering the efflux bundle 5. This
- 60 light is then detected by the silicon photodiode 10, and the optical signal is processed and displayed by the display unit 11. The dispersion 13 is held in a cell 6 with an optically-absorbing base 7. This cell is rotatable by stepping motor 9 via shaft 8, either continuously, or in steps in one direction, or in steps in alternate directions. These then give a continuous shear, or time-dependent shears, respectively. The mode of shear, the shear rate and the angle of shear are
- 65 controlled by the motor control logic 12. 65

The path length i.e. the distance from the end of the fibre bundle to the bottom of the cell may be varied using a simple variable height clamp not shown. This distance can be measured using a dial gauge.

In a practical realisation of the instrument, as shown in Fig. 2, the dispersion end of the bifurcated bundle is surrounded by a collar 14 to reduce radial flow of the dispersion. An on-line or continuous-flow instrument can be envisaged by incorporating inlet 15 and outlet 16 sampling tubes into such a collar, where the shear rate due to the pumped flow is made small relative to the maximum shear rate set up by the cell rotation. A flexible coupling 17 allows optically-absorbing base 7 to be rotated relative to collar 14 by steps in alternate direction, i.e. oscillating shear flow is established between optically-absorbing base 7 and the common end 18 of the bifurcated fibre bundle.

A series of experiments were carried out, using an instrument embodying the invention, under the following conditions:

15	Temperature:	22°.	15
	Wavelength:	White Light.	
	Colloidal Material:	A commercial kaolinite clay with a particle size distribution such that 80% (by weight) of the kaolinite is of equivalent stokes diameter less than 2 micrometres.	
20	Dispersion:	The clay as specified above dispersed in water at a concentration of 20% (by weight).	20
	State of Flocculation:	Fig. 3a ("defloc" curve) and Fig. 3b both refer to a dispersion pH=9. Fig. 3a ("floc" curve) is for a pH<6.5.	
	Apparatus:	The shear gap between the fibre optic bundle (4/5 in Fig. 1) and the base (7 in Fig. 1) was 0.4 mm.	
25	Shear Rate:	As shown on the graph abscissa of Fig. 3b. The shear rate (prior to being turned off) in Fig. 3a was 8. reciprocal seconds.	25

Fig. 3a shows typical experimental results for a flocculated and deflocculated clay dispersion, $\Delta R/R$ being the relative change in the diffuse reflectance, as a measure of backscattering, and t indicating time. Fig. 3b shows $\Delta R/R$ for a deflocculated dispersion as a function of average velocity gradient of the cell 6.

Fig. 4 shows a version of the monitor by which means the explicit shear-rate dependence of the back-scattering may be measured. Shear is set up between the optically-absorbing rotating base 107 and the stationary disc-plate 119. A series of bifurcated optical bundles are disposed spirally (as seen in plan view—see Fig. 4A) around the plate 119 and detect and measure the back-scattering at various radial distances from the axis of rotation of the optically-absorbing base 117. For illustration only two bundles 120, 121 are shown in Fig. 4 but a spiral series of, say, nine might be used, as shown in Fig. 4A. The shear rate increases linearly with radial distance. The spiral disposition minimises the cross-transfer of light within the dispersion from one common bundle to another. The light influx to each bifurcated bundle is from a common source 101 with wavelength-selective filter 3, with separate optical detectors 122, 123 etc. attached to each efflux bundle.

Alternatively to avoid the cross-transfer of light, separate light-emitting diode sources could be used attached to each influx bundle which could interrogate the backscattering of the sheared dispersion by being rapidly and sequentially switched on and off by a logic circuit such that no more than one bundle is illuminated at any one time. In this arrangement a common photodetector can be used to detect the light from the separate efflux bundles. In this version of the monitor the rotation of the optically-absorbing base 107 could be time-dependent and produce a time-dependent shear for monitoring flocculation as previously described. Alternatively steady rotation of the base 107 can be used, the radial variation of shear rate across disc 119 then being used to monitor flocculation, by comparing the back-scattering from any bifurcated bundle with the central one at which the shear rate is practically zero.

Fig. 5 shows a version of the monitor in which shear is generated by flowing the dispersion through a parallel-sided flow cell 224 having no moving parts, and in which both the forward and backward light scattering are detected and measured by bifurcated bundles 225, 226. To monitor flocculation the shear can either be varied in time by means of a variable-speed pump 227 or a combination of a steady pump rate and a periodically actuated valve 228. As the forward- and back-scattered light intensity changes on shear are usually of opposite sign, the flocculation detection can be made more sensitive by any means of electronically subtracting the changes or by measuring their ratio. The ratio method is preferred if a common light source is used, as it removes accidental signals originating from fluctuations in the light source intensity.

CLAIMS

1. A flocculation monitor comprising a vessel or cell adapted to contain a dispersion of free

- or discrete colloidal particles, means for introducing incident light into the dispersion and for recovering reflected light from the dispersion and measuring changes in scattering, and means for subjecting the dispersion of colloidal particles to a shearing force either by rotating the vessel continuously or in steps in one direction or in alternate directions, or by steady or
 5 fluctuating flow. 5
2. An optical flocculation monitor according to claim 1 and in which the means for introducing incident light comprises a source of incoherent or diffuse light.
3. An optical flocculation monitor according to claim 1 or claim 2 and in which means for introducing incident light and recovering reflected light comprises incoherent optical fibres.
- 10 4. An optical flocculation monitor according to claim 3 and in which the optical fibres are in bundles. 10
5. An optical flocculation monitor according to claim 3 or claim 4 and in which said optical fibres or bundles of optical fibres extend into said vessel so that, in use, they extend into said dispersion.
- 15 6. An optical flocculation monitor according to any preceding claim and in which the incident light is passed through a variable wavelength interference filter to enable a maximum reflectance change to be achieved for the particular dispersion which is to be measured. 15
7. An optical flocculation monitor according to any preceding claim and in which the vessel is rotated in steps by an electrical stepping motor.
- 20 8. An optical flocculation monitor according to claim 7 and in which said stepping motor is controlled by a motor control logic circuit. 20
9. An optical flocculation monitor according to any of Claims 1 to 6 and in which the shearing force is generated by flowing the dispersion through a parallel side cell.
10. An optical flocculation monitor according to claim 9 and in which shear is varied by
 25 means of a variable speed pump or by means of a periodically actuated valve. 25
11. An optical flocculation monitor according to any of claims 1 to 6 and in which there are a number of bundles of optical fibres arranged in an array on a stationary plate to detect and measure back-scattering at various radial distances from the axis of rotation of an optically-absorbing base by which explicit shear rate dependence of the back-scattering may be measured.
 30 30
12. An optical flocculation monitor according to claim 11 and in which said array is a spiral array.
13. An optical flocculation monitor substantially as hereinbefore particularly described and as illustrated in any of the accompanying drawings.