



(72) HUGHES, GRAHAM J., GB

(72) CHAMBERS, GEOFFREY R., GB

(71) ABBOTT LABORATORIES, US

(51) Int.Cl.<sup>7</sup> C12Q 1/00, C12Q 1/54, G01N 27/327

(30) 1997/09/05 (08/924,266) US

(54) **CAPTEUR ELECTROCHIMIQUE COMPRENANT DES  
SURFACES D'ELECTRODES EQUILIBREES**

(54) **ELECTROCHEMICAL SENSOR HAVING EQUALIZED  
ELECTRODE AREAS**

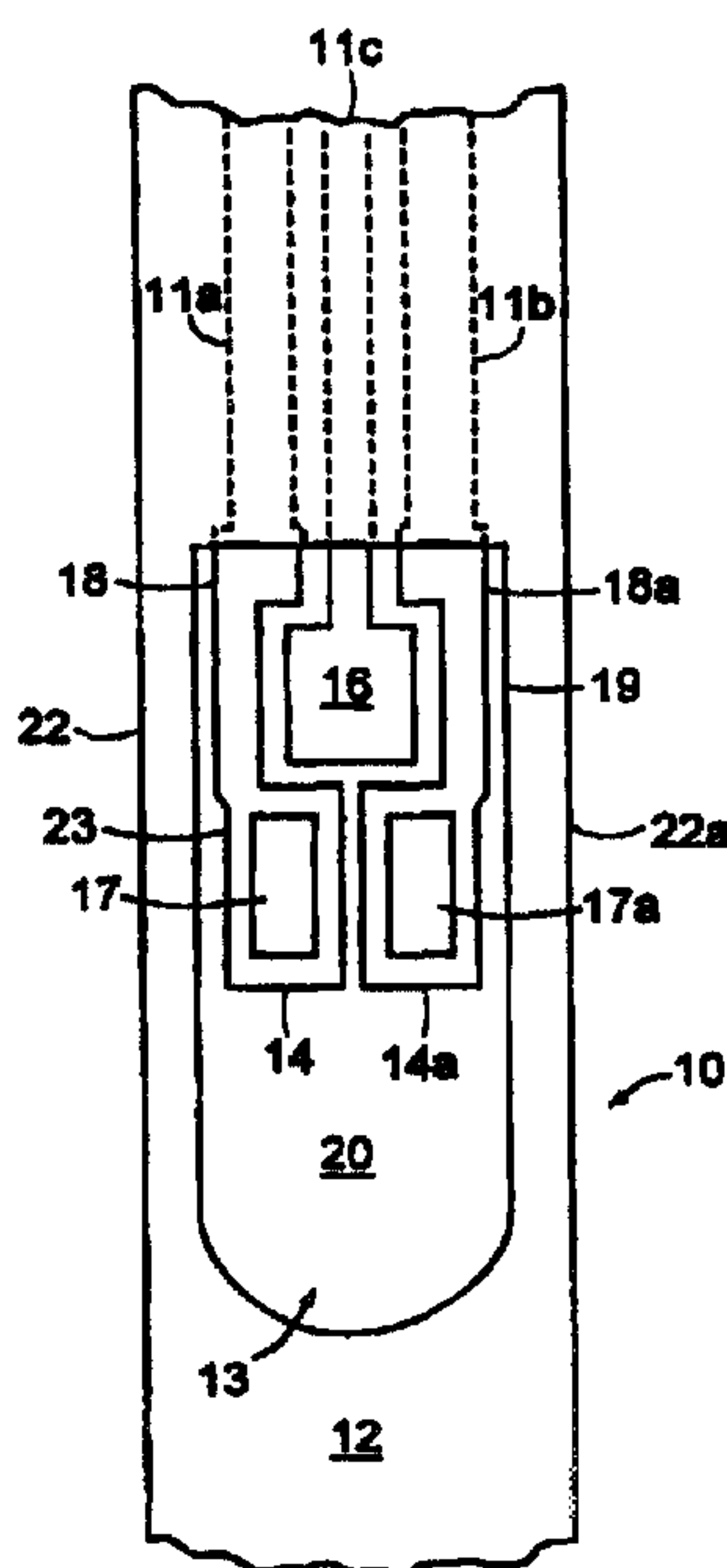

(57) Cette invention concerne une bandelette de capteur électrochimique. Dans une bandelette de capteur à plusieurs électrodes, l'équilibrage des surfaces non actives ainsi que des surfaces actives d'électrodes améliore la précision et l'exactitude globale des mesures effectuées à l'aide de la bandelette de capteur. L'effet bénéfique de l'équilibrage des surfaces est plus prononcé avec des concentrations de glucose relativement faibles. Dans cette invention, l'exactitude et la reproductibilité de l'équilibrage des surfaces d'électrodes est améliorée du fait qu'on évite le chevauchement entre les électrodes et un revêtement diélectrique qui définit une surface d'exposition de l'électrode.

(57) An improved electrochemical sensor strip is disclosed. In a multiple electrode sensor strip, equalization of electrode nonworking areas, as well as working areas, enhances the overall precision and accuracy of the measurements made using the sensor strip. The beneficial effect of area equalization is most pronounced at relatively low glucose concentrations. In the present invention, the exactness and reproducibility of electrode area equalization is improved by avoidance of overlap between the electrodes and a dielectric coating that defines an electrode exposure area.





PCT

WORLD INTELLECTUAL PROPERTY ORGANIZATION  
International Bureau

## INTERNATIONAL APPLICATION PUBLISHED UNDER THE PATENT COOPERATION TREATY (PCT)

(51) International Patent Classification <sup>6</sup> : C12Q 1/00, G01N 27/327, C12Q 1/54	A1	(11) International Publication Number: <b>WO 99/13099</b> (43) International Publication Date: 18 March 1999 (18.03.99)
<p>(21) International Application Number: PCT/US98/18216</p> <p>(22) International Filing Date: 2 September 1998 (02.09.98)</p> <p>(30) Priority Data: 08/924,266 5 September 1997 (05.09.97) US</p> <p>(71) Applicant: ABBOTT LABORATORIES [US/US]; CHAD 0377/AP6D-2, 100 Abbott Park Road, Abbott Park, IL 60064-3500 (US).</p> <p>(72) Inventors: HUGHES, Graham, J.; 23 New Cross Road, Headington, Oxford OX3 8LP (GB). CHAMBERS, Geoffrey, R.; 32 Elgood Avenue, Northwood, Middlesex HA6 3QS (GB).</p> <p>(74) Agents: POPE, Lawrence, C. et al.; Abbott Laboratories, CHAD 0377/AP6D-2, 100 Abbott Park Road, Abbott Park, IL 60064-3500 (US).</p>	<p>(81) Designated States: AL, AM, AT, AU, AZ, BA, BB, BG, BR, BY, CA, CH, CN, CU, CZ, DE, DK, EE, ES, FI, GB, GE, GH, GM, HR, HU, ID, IL, IS, JP, KE, KG, KP, KR, KZ, LC, LK, LR, LS, LT, LU, LV, MD, MG, MK, MN, MW, MX, NO, NZ, PL, PT, RO, RU, SD, SE, SG, SI, SK, SL, TJ, TM, TR, TT, UA, UG, UZ, VN, YU, ZW; ARIPPO patent (GH, GM, KE, LS, MW, SD, SZ, UG, ZW), Eurasian patent (AM, AZ, BY, KG, KZ, MD, RU, TJ, TM), European patent (AT, BE, CH, CY, DE, DK, ES, FI, FR, GB, GR, IE, IT, LU, MC, NL, PT, SE), OAPI patent (BF, BJ, CF, CG, CI, CM, GA, GN, GW, ML, MR, NE, SN, TD, TG).</p> <p><b>Published</b> <i>With international search report.</i></p>	

(54) Title: ELECTROCHEMICAL SENSOR HAVING EQUALIZED ELECTRODE AREAS

## (57) Abstract

An improved electrochemical sensor strip is disclosed. In a multiple electrode sensor strip, equalization of electrode nonworking areas, as well as working areas, enhances the overall precision and accuracy of the measurements made using the sensor strip. The beneficial effect of area equalization is most pronounced at relatively low glucose concentrations. In the present invention, the exactness and reproducibility of electrode area equalization is improved by avoidance of overlap between the electrodes and a dielectric coating that defines an electrode exposure area.

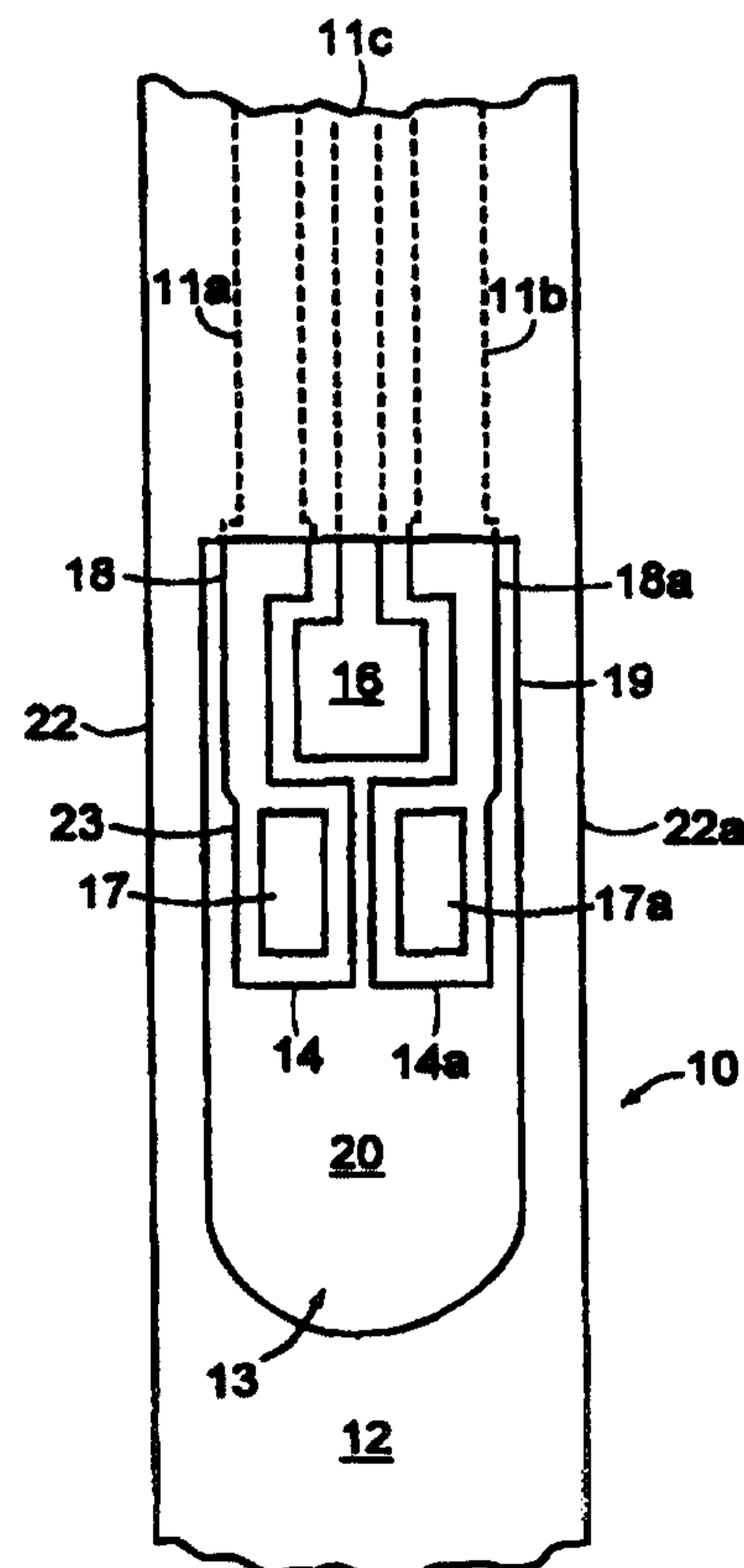

## ELECTROCHEMICAL SENSOR HAVING EQUALIZED ELECTRODE AREAS

### Field of the Invention

The invention relates to electrochemical sensors, biomedical testing, and blood analysis.

### Background of the Invention

5 Electrochemical assays for determining the concentration of enzymes or their substrates in complex liquid mixtures have been developed. For example, electrochemical sensor strips have been developed for the detection of blood glucose levels. Electrochemical sensor strips generally include an electrochemical cell in which there is a working electrode and a reference electrodes. The potential of the working electrode typically is kept at a constant value relative to that of the reference electrode.

10 Electrochemical sensor strips are also used in the chemical industry and food industry, to analyze complex mixtures. Electrochemical sensors are useful in biomedical research, where they can function as invasive probes, and for external testing (i.e., testing of blood obtained by a needle and syringe, or a lance).

15 Typical electrochemical sensors for blood analysis measure the amount of analyte in a blood sample by using a working electrode coated with a layer containing an enzyme and a redox mediator and a reference electrode. When the electrodes contact a liquid sample containing a species for which the enzyme is catalytically active, the redox mediator transfers electrons in the catalyzed reaction. When a voltage is applied across the electrodes, a response current results from the reduction or oxidation of the redox mediator at the electrodes. The response current is proportional to the concentration of the substrate. Some sensors include a dummy electrode coated with a layer containing the redox mediator but lacking the enzyme. The response current at the dummy electrode represents a background response of the electrode in contact with the sample. A corrected response is derived by subtracting the response of the dummy electrode from the response of the working electrode. This dummy subtraction process substantially eliminates background interferences, thereby improving the signal-to-noise ratio in the electrode system.

### Summary of the Invention

30 It has been discovered that equalizing the exposed areas of electrode regions having no electrochemical reaction components by which to generate a catalytic current increases the accuracy and precision of analyte concentration measurements. This result was unexpected. According to conventional electrochemical theory, the magnitude of current from such areas

should be negligible relative to the current generated at the working areas of the electrodes.

Based on this discovery, the invention features an improved electrode strip for use in an electrochemical sensor for measuring an analyte in a sample. The electrode strip includes an electrode support, which has a first support edge and a second support edge, and an electrode arrangement on the support. The electrode arrangement includes a working electrode, a dummy electrode, and a reference electrode. The working electrode includes a working area, which contains assay reaction components, including an enzyme and a redox mediator. The working electrode also includes an extension, which is substantially free of the enzyme and redox mediator, and an outside edge. The dummy electrode includes a working area, which contains assay reaction components, except the enzyme. The dummy electrode also includes an extension, which is substantially free of assay reaction components, and an outside edge. The reference electrode has a working area-facing side and an extension-facing side. The working area extension is located between the reference electrode and the first support edge. The dummy electrode extension is located between the reference electrode and the second support edge. The electrode strip includes a dielectric coating, which covers a portion of the support. The covered portion of the support includes an area located between the working electrode extension and the first support edge, and an area located between the dummy electrode extension and the second support edge, and the dielectric coating covers no portion of the outside edge of the working electrode or the outside edge of the dummy electrode.

Preferably, the dielectric coating surrounds the electrode arrangement in which the working electrode and the dummy electrode have equal areas. Preferably, each electrode is a printed electrode. Preferably, the enzyme is an enzyme that reacts with glucose, for example, glucose oxidase or glucose dehydrogenase. The redox mediator can be any electrochemically active compound that accepts or donates an electron to an enzyme. Redox mediators include ferrocene, ferrocene derivatives, ferricyanide, and osmium complexes.

Unless otherwise defined, all technical and scientific terms used herein have the same meaning as commonly understood by one of ordinary skill in the art to which this invention belongs. In case of conflict, the present application, including definitions will control. All publications, patent applications, patents, and other references mentioned herein are incorporated by reference.

Although methods and materials similar or equivalent to those described herein can be used in the practice or testing of the present invention, the preferred methods and materials

are described below. The materials, methods, and examples are illustrative only and not intended to be limiting.

Other features and advantages of the invention will be apparent from the detailed description, and from the claims.

#### Brief Description of the Drawings

Fig. 1 is a top view of the electrode region of a prior art electrode sensor strip.

Fig. 2 is a top view of a preferred embodiment of an electrode strip according to the present invention.

Fig. 3 is an exploded view of an electrode strip according to one embodiment of the invention.

Fig. 4 is a perspective view of the assembled strip shown in Fig. 3.

#### Description of the Preferred Embodiments

In a multiple electrode sensor strip, equalization of electrode nonworking areas, as well as working areas, enhances the overall precision and accuracy of the measurements made using the sensor strip. The beneficial effect of area equalization is most pronounced at relatively low glucose concentrations. In the present invention, the exactness and reproducibility of electrode area equalization is improved by avoidance of overlap between the electrodes and a dielectric coating that defines an electrode exposure area.

The invention is illustrated by comparison of Figs. 1 and 2, which depict a prior art electrode strip and an electrode strip of the invention, respectively. Referring to Fig. 1, the electrode strip 10 has three printed tracks of electrically conducting carbon ink 11a, 11b, 11c. A dielectric coating 12 partially covers the electrode strip 10 and defines an open area 13, which includes an electrode arrangement 19 and a sample loading area 20. Each printed track of electrically conducting carbon ink 11a, 11b, 11c terminates in an electrode, in the open area 13. One track 11a terminates in a working electrode 14. A second track 11b terminates in a dummy electrode 14a. A third track terminates in a reference electrode 16.

The working electrode 14 includes a working area 17, which contains components of an analyte assay reaction, including glucose oxidase and a ferrocene redox mediator. The working electrode also includes an extension 18, which is a non-working area, i.e., it does not contain any assay reaction components.

The dummy electrode includes 14a a working area 17a, which contains components of the assay assay reaction, except the enzyme, glucose oxidase. The dummy electrode also includes an extension 18a, which is a non-working area, i.e., it does not contain any assay

reaction components. The geometry of the dummy electrode 14a forms a mirror image of the working electrode 14.

The reference electrode 16 is situated so that one side faces the working areas 17, 17a, one side faces the working electrode extension 18, and one side faces the dummy electrode extension 18a.

In the prior art electrode depicted in Fig. 1, dielectric coating 12 covers a portion of the working electrode 14 and dummy electrode 14a, thereby forming a pair of small overlap regions 21, 21a.

Referring to Fig. 2, the electrode strip 10 has three printed tracks of electrically conducting carbon ink 11a, 11b, 11c. A dielectric coating 12 partially covers the electrode strip 10 and defines an open area 13, which includes an electrode arrangement 19 and a sample loading area 20. Each printed track of electrically conducting carbon ink 11a, 11b, 11c terminates in an electrode, in the open area 13. One track 11a terminates in a working electrode 14. A second track 11b terminates in a dummy electrode 15. A third track terminates in a reference electrode 16.

The working electrode 14 includes a working area 17, which contains components of an analyte assay reaction, including glucose oxidase and a ferrocene redox mediator. The working electrode also includes an extension 18, which is a non-working area, i.e., it does not contain any assay reaction components.

The dummy electrode includes 14a a working area 17a, which contains components of the assay reaction, except the enzyme, glucose oxidase. The dummy electrode also includes an extension 18a, which is a non-working area, i.e., it does not contain any assay reaction components. The geometry of the dummy electrode 14a forms a mirror image of the working electrode 14.

The reference electrode 16 is situated so that one side faces the working areas 17, 17a, one side faces the working electrode extension 18, and one side faces the dummy electrode extension 18a.

In the electrode depicted in Fig. 2, the dielectric coating 12 extends along the electrode support edges 22, 22a. However, the width of the open area 13 is greater than the width of the electrode arrangement 19. This creates a gap between the outside edges of the working and electrodes, and the surrounding dielectric coating 12. Therefore, the dielectric coating 12 covers no portion of the outside edge of the working electrode 14 or the outside edge of the dummy electrode 14a. The overlap regions 21, 21a, which are present in the prior art

electrode strip 10 depicted in Fig. 1, are absent from the electrode strip 10 depicted in Fig. 2.

A gap can be created between the outside edges of the electrodes and the surrounding dielectric coating by narrowing the electrodes, or by widening the open area, or both. The extent of electrode narrowing is limited, in part, by the overall resistance of the electrode system and printing tolerances.

As the width of the electrode arrangement 19 and the width of the open area 13 are made closer, imperfect registration of electrode strip layers can cause the dielectric coating 12 inadvertently to overlap an outside edge 23, 23a of the working electrode 14 or the dummy electrode 14a. Preferably, the difference between electrode arrangement 19 width and open area 13 width is great enough to accommodate layer registration tolerances in a manufacturing process without any overlap of dielectric coating 12 onto electrode edges.

Preferably, the dielectric coating is bonded securely to the electrode support, mesh layers, and to an electrode strip cover layer (e.g., polyester tape). Preferably, the dielectric layer is hydrophobic. This enhances its ability to confine an aqueous sample to the electrode area. Preferred materials for use as the dielectric coating are POLYPLAST<sup>®</sup> and SERICARD<sup>®</sup> (Sericol Ltd., Broadstairs, Kent, UK), with SERICARD<sup>®</sup> being more preferred.

The working electrode working area 17 is formed from an ink that includes an enzyme, a redox mediator, and a filler. The dummy electrode working area 17a is formed from an ink that includes the redox mediator and filler, but does not include the enzyme. The respective inks can be applied to the carbon tracks 11a, 11b by printing, to form discrete working areas 17, 17a. When the analyte to be measured is blood glucose, the enzyme is preferably glucose oxidase, and the redox mediator is a ferrocene derivative.

Referring to Fig. 3, the various layers that make up the electrode strip are laid down on an electrode support 36. The electrode support is typically a plastic material such as PVC, polycarbonate, or polyester. Three printed tracks of electrically conducting carbon ink 11a, 11b, 11c formed on the electrode support 36. Silver/silver chloride tracks 35a, 35b, 36c are then overlaid onto the carbon ink tracks 11a, 11b, 11c.

Referring to Fig. 3, two surfactant coated mesh layers 30, 31 overlay the electrode arrangement 19. The mesh layers protect the printed components from physical damage. They also facilitate wetting of the electrodes by the aqueous sample. Preferably, the mesh layers extend over the entire sample path, between and including, the sample loading area 20

and the electrode arrangement 19. Finely woven nylon is suitable for the mesh layers. Alternatively, any woven or non-woven material can be used. For a detailed discussion of the mesh layers see Carter et al., U.S. Patent No. 5,628,890, which is herein incorporated by reference.

5 If the mesh material is hydrophobic (e.g., nylon or polyester), it is coated with a surfactant. If a hydrophilic mesh is used, the surfactant coating can be omitted. Hydrophilicity of the mesh allows the sample to wick along the mesh layer to the electrodes. The wicking properties of the mesh can be controlled by changing the type or amount of surfactant on the mesh material. Various surfactants are suitable for coating the mesh material. A preferred surfactant is FC 170C FLUORAD<sup>®</sup> fluorochemical surfactant  
10 (3M, St. Paul, MN). FLUORAD<sup>®</sup> is a solution of a fluoroaliphatic oxyethylene adduct, lower polyethylene glycols, 1,4-dioxane, and water.

The preferred surfactant loading will vary depending on the type of mesh and surfactant used and the sample to be analyzed. It can be determined empirically by observing flow of the sample through the mesh with different levels of surfactant. If two mesh layers are used,  
15 the second (upper) mesh layer preferably is hydrophilic, but not more hydrophilic than the first (lower) mesh layer. Accordingly, the first mesh layer can have a greater load of surfactant than the second mesh layer. With regard to the first mesh layer, suitable surfactant loading for most applications is about 15-20  $\mu$ g/mg of mesh (i.e., about 1.0 percent w/v). With regard to the second mesh layer, suitable surfactant loading for most  
20 applications is about 1-10  $\mu$ g/mg of mesh.

The mesh layers 30, 31 are held in place by a dielectric coating 12, which impregnates the periphery of the mesh layers 30, 31. The dielectric coating 12 can be applied by screen printing. The dielectric coating 12 covers no portion of the electrode arrangement 19.  
25 Preferably, the dielectric coating is hydrophobic, so that it efficiently confines the sample. Preferably, the hydrophobic dielectric coating is POLYPLAST<sup>®</sup> (Sericol Ltd., Broadstairs, Kent, UK). More preferably, it is SERICARD<sup>®</sup> (Sericol).

The uppermost layer on the electrode strip is a cover layer 32. Preferably, the cover layer is substantially impermeable. A suitable material for formation of the cover layer 32 is  
30 a flexible polyester tape.

The cover layer 32 defines an upper boundary of the electrochemical cell volume, and thus, the cover layer 32 determines the maximum depth of the aqueous sample. The cover layer 32 fixes the upper boundary of the cell volume at a predetermined height, which

depends on the thickness of the mesh layers 30, 31. The cell height, and thus maximum sample depth, is selected to ensure a suitably high solution resistance.

The cover layer 32 has an aperture 33 for sample access to the underlying mesh layers 30, 31. The aperture 33 is located over the sample loading area 20, which is adjacent to the upstream ends of the working electrode 14 and dummy electrode 14a. The aperture 33 can be of any suitable size large enough to allow sufficient volume of sample to pass through to the mesh layers 30, 31. It should not be so large as to expose any portion of the electrode arrangement 19. The aperture 33 can be formed in the cover layer 32 by any suitable method, e.g., die punching.

Cover layer 32 is peripherally affixed to the strip by means of a suitable adhesive. The cover layer 32 is not affixed in the area of the electrode arrangement 19, the sample loading area 20, or the area therebetween. Preferably, the cover layer 32 is affixed by means of a hot melt adhesive. The hot melt adhesive typically has a coating weight between 10 and 50 g/m<sup>2</sup>, preferably from 20 to 30 g/m<sup>2</sup>. Pressure sensitive adhesives or other suitable adhesives can also be used. When a heat sensitive dielectric coating 12 is used, e.g., SERICARD<sup>®</sup>, heat welding of the cover layer 32 should be carried out in a manner that does not damage the dielectric coating 12.

Optionally, the upper surface of the cover layer 32 can be coated with a layer of silicone or other hydrophobic coating. This helps to drive the applied sample onto the hydrophilic mesh layers 30, 31 at the sample loading area 20, thus facilitating the application of small volumes.

Referring to Fig. 4, an electrode strip 10 of the invention is connected, via electrode contacts 34, to a compatible meter (not shown), after a sample is placed in aperture 33.

The following examples are intended to be illustrative and not limiting of the invention.

#### Example 1 - Spiked Venous Blood Testing

Eleven batches of electrode strips essentially as shown in Fig. 2 were constructed. In addition, a batch of prior art control strips as shown in Fig. 1, were constructed.

Samples of venous blood were collected in four studies and spiked with various concentrations of glucose. Small volumes of each samples were applied to the target area of the sample and control strips and allowed to cover the working and reference electrodes. The responses of the strips to the glucose concentration in the blood were measured after a steady state response was achieved, using an appropriate meter.

The average calibration results for the eleven batches were calculated and are listed in

Table 1. The data include the standard deviations of the results ("S.D.") and the coefficients of variation ("CV").

Table 1

Glucose Level	Mean (mM)	Pooled S.D. (mM)	CV (%)
1	2.6	0.16	6.1
2	5.1	0.27	5.3
3	9.9	0.44	4.4
4	14.3	0.64	4.5

5 For comparison, the average precision results for the control batch are listed in Table 2. The standard deviations and coefficients of variation were consistently higher in the control strips.

Table 2

Glucose Level	Mean (mM)	Pooled S.D. (mM)	CV (%)
1	2.7	0.28	10.2
2	5.1	0.34	6.7
3	10.1	0.52	5.1
4	15.1	0.71	4.7

#### 10 Example 2 - Control Solution Testing

A standard precision test using 96 replicate measurements of an aqueous solution with a glucose concentration of 2.0 mM was carried out on eleven batches of electrodes of this invention. The results were compared to results from a corresponding test carried out on control (prior art) electrode batches. The results are shown in Table 3.

Table 3

Mean Response (mM)	SD	% CV
Test Batches	2.4	5.8
Control Batches	2.3	10.87

15 Other embodiments are within the following claims.

## Claims

We claim:

1. An electrode strip for use in an electrochemical sensor for measuring an analyte in an aqueous sample, comprising:

- 5 (a) an electrode support comprising a first support edge and a second support edge;
- (b) an electrode arrangement on said support, comprising a working electrode, a dummy electrode, and a reference electrode, wherein:
- (1) said working electrode comprises:
- (i) an outside edge;
- 10 (ii) a working area comprising an enzyme and a redox mediator, and
- (iii) an extension substantially free of said enzyme and said redox mediator;
- (2) said dummy electrode comprises:
- (i) an outside edge;
- (ii) a working area comprising a redox mediator and being substantially free of said
- 15 enzyme, and
- (iii) an extension substantially free of said enzyme and said redox mediator;
- (3) said reference electrode comprises a working area-facing side and an extension-facing side; and
- (4) said working electrode extension is located between said reference electrode and said
- 20 first support edge, and said dummy electrode extension is located between said reference electrode and said second support edge; and
- (5) the area of said working electrode extension and the area of said dummy electrode extension are equal; and
- (c) a dielectric coating, wherein: said dielectric coating covers a portion of said support,
- 25 which portion is located between said working electrode extension and said first support edge, and said dummy electrode extension and said second support edge; and said dielectric coating covers no portion of said outside edge of said working electrode or said outside edge of said dummy electrode.
2. The electrode strip of claim 1, wherein said dielectric coating surrounds said
- 30 electrode arrangement.
3. The electrode strip of claim 1, wherein each electrode is a printed electrode.
4. The electrode strip of claim 1, wherein said enzyme is glucose oxidase and said redox mediator a ferrocene.

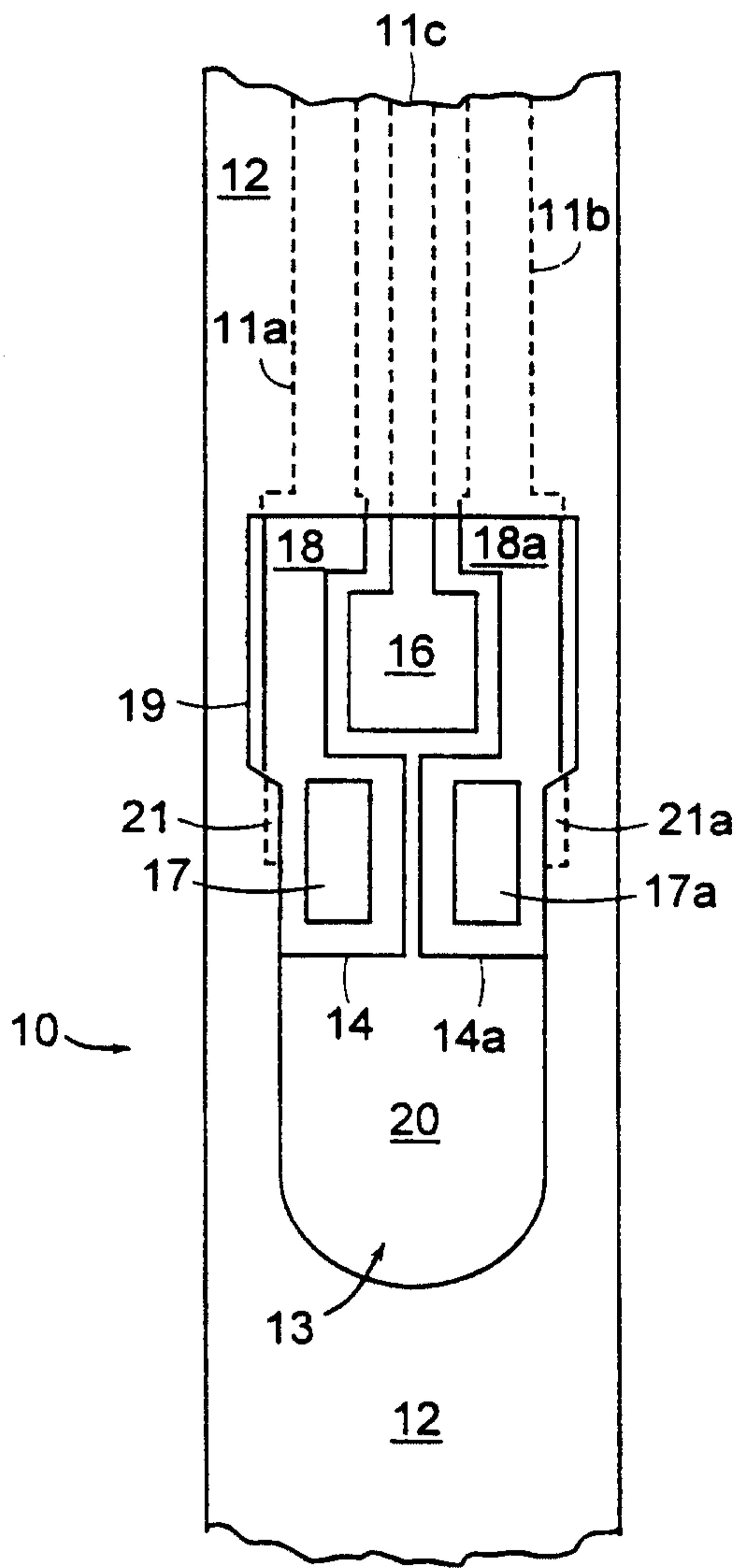

PRIOR ART  
FIG. 1

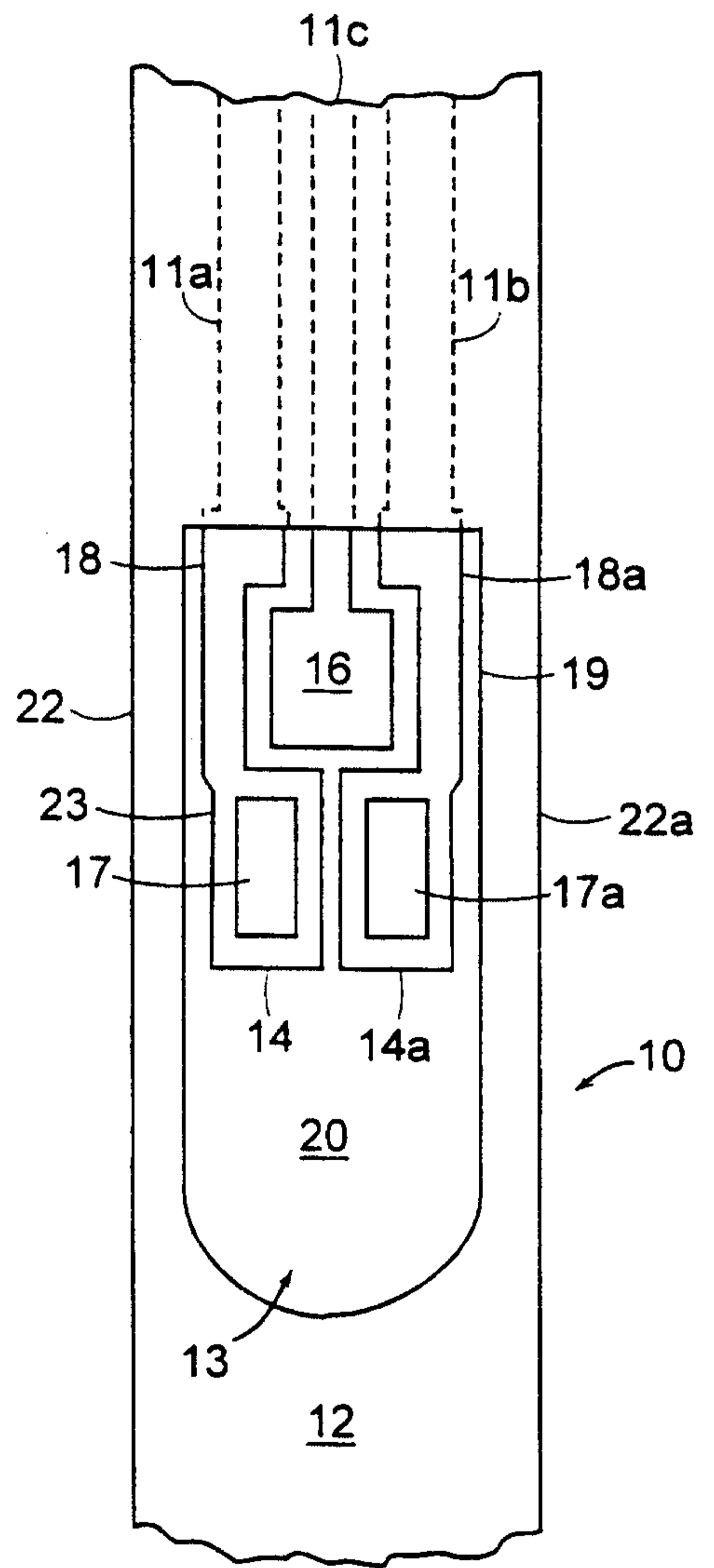

FIG. 2

2/2

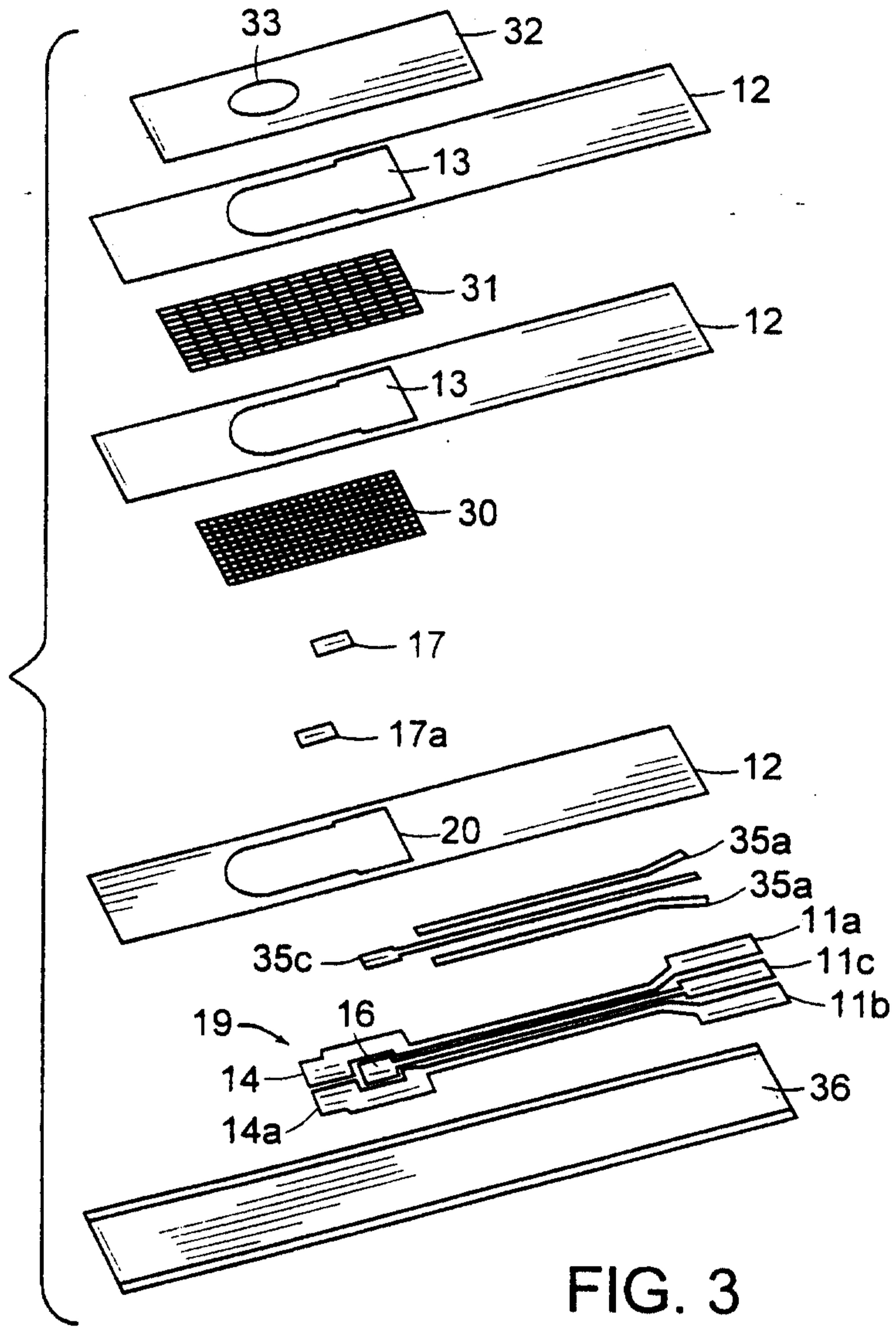

FIG. 3

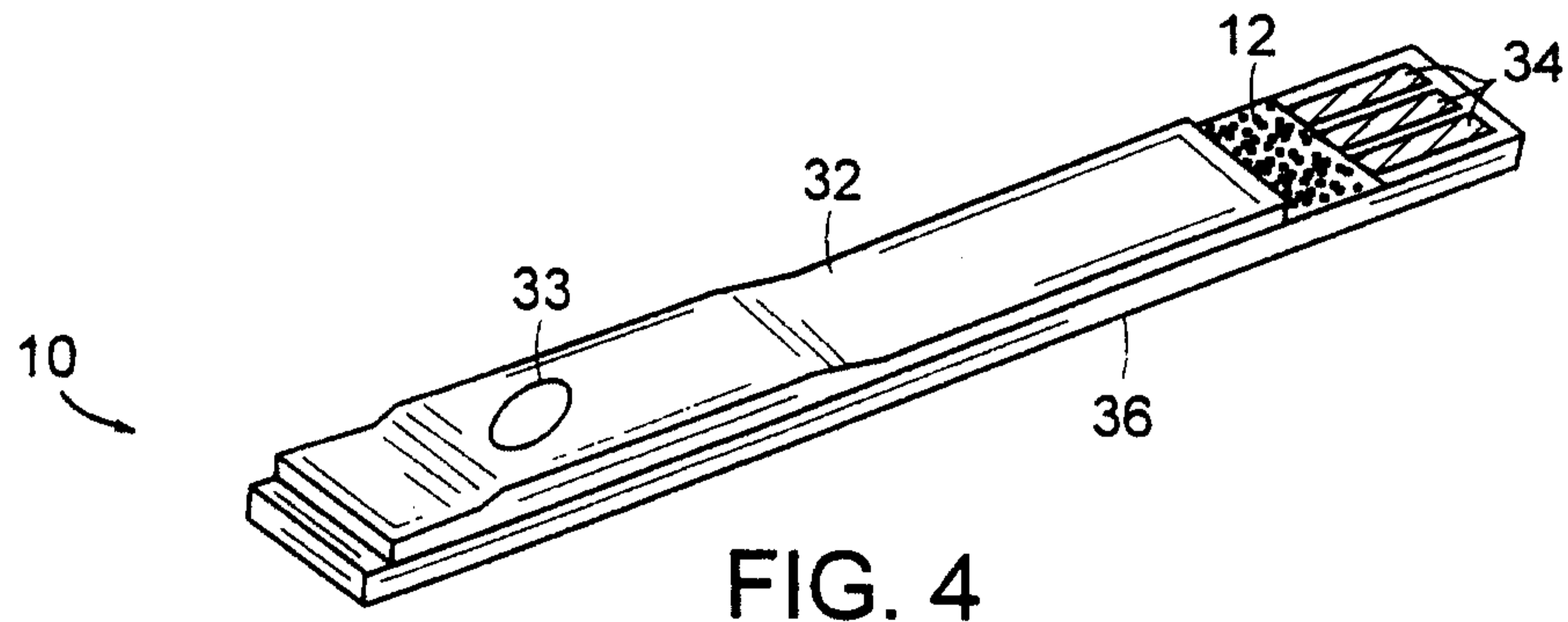

FIG. 4