

A. MAYER.

Gas Stove.

No. 11,259.

Patented July 11, 1854.

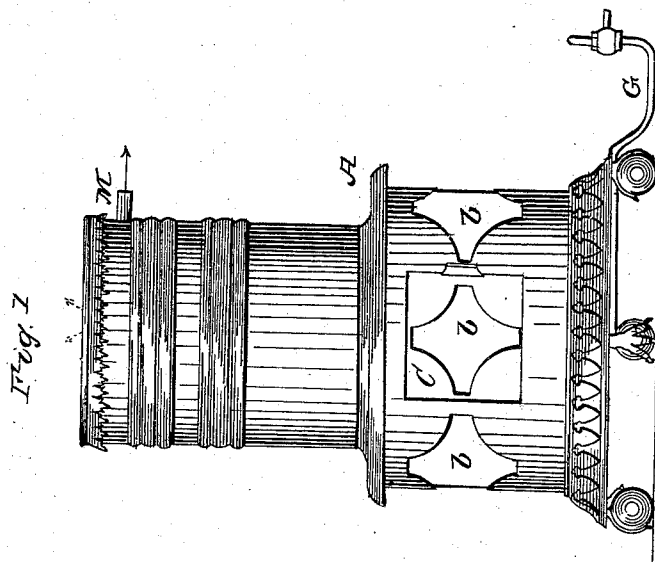
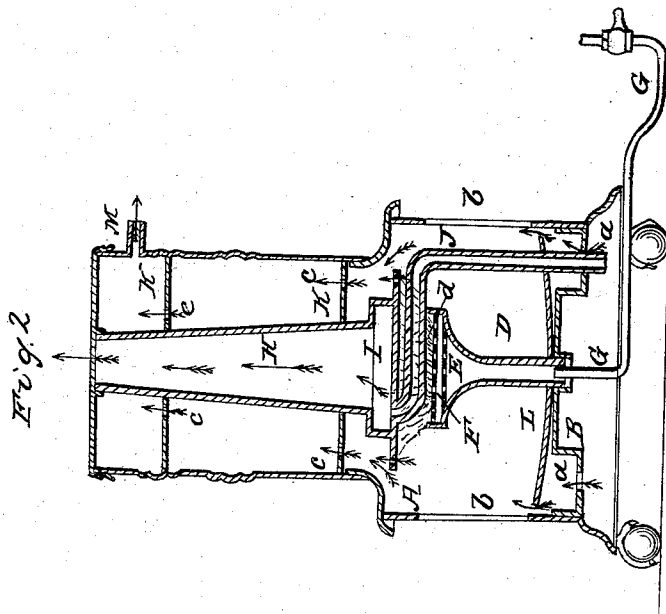

UNITED STATES PATENT OFFICE.

ANDREW MAYER, OF PHILADELPHIA, PENNSYLVANIA.

GAS-STOVE.

Specification of Letters Patent No. 11,259, dated July 11, 1854.

To all whom it may concern:

Be it known that I, ANDREW MAYER, of the city and county of Philadelphia and State of Pennsylvania, have invented a new and Improved Gas-Stove; and I do hereby declare that the following is a full, clear, and exact description of the same, reference being had to the annexed drawings, making a part of this specification, in which—

Figure 1, is an external view of the stove in elevation. Fig. 2, is a vertical section of the same, the plane of section being through the center.

Similar letters of reference indicate corresponding parts in the two figures.

This invention relates to a new and improved stove for heating apartments by burning gas.

The nature of the invention consists in the peculiar construction of the stove, or the arrangement of the several parts, whereby the whole amount of heat from the burning gas, is radiated or diffused in the apartment, and all unpleasant odor avoided.

To enable others skilled in the art to fully understand and construct my invention, I will proceed to describe it.

A, represents the body or case of the stove, of cylindrical, or other shape, and having a bottom, B, provided with apertures or slots, (a), for the admission of air, see Fig. 2. The lower part of the body or case, A, is provided with a door, C, see Fig. 1, and may also have apertures, (b), through its side, covered with mica.

D, is a tube inserted in the center of the bottom plate, B, of the stove. The upper end of the tube is trumpet shaped, as shown in Fig. 2, and has a perforated disk, E, within it, and also a wire cloth screen, F; a suitable space being between the disk and screen. The lower end of the tube, D, communicates with a gas pipe, G.

H, Fig. 2, is an air heating pipe, or chamber, placed vertically within the case, A, and at its center. The bottom, I, of the pipe or chamber is constructed of copper, and is a short distance above the upper part of the tube, D. The bottom, I, is larger in diameter than the upper part of the tube, D. The chamber, or pipe, H, communicates with the external air at the upper part of the body, or case, A.

J, is a pipe which is connected to the bottom of the chamber, or pipe, H. The pipe, J, is bent, and passes between the bottom, I,

and upper end of the tube, D, and passes down through one of the slots, (a), in the bottom, B, of the body, or case, A.

K, K, Fig. 2, are two disks placed around the chamber or pipe, H, at suitable distances apart. The edges of these disks are in close contact with the side of the body, or case, A; and are perforated with holes, (c); the holes in the upper disk being nearer the pipe or chamber, H, than the holes in the lower disk.

L, is a disk at the lower part of the tube, D. This disk extends nearly to the side of the body, or case, leaving a small space, sufficient for the admission of air to feed the flame. On the top of the wire cloth screen, F, is placed a quantity of pumice stone, asbestos, or other incombustible substance, see (d), Fig. 2.

The bottom, I, of the chamber, or pipe, H, is of copper, as before stated, the other parts may be constructed of iron.

When it is designed to use the stove, the gas is allowed to pass into the tube, D, by turning a faucet in the pipe, G, and the gas is distributed, or spread over the whole surface of the upper part of the tube, D, by the perforated disk, E. The gas is ignited at the upper end of the tube, as it passes through the pumice stone, or asbestos, and the copper bottom, I, soon become heated, and the cold air within the chamber, or pipe, H, also becomes heated, and escapes into the room or apartment. The dotted arrows, Fig. 2, show the passage of the air into the chamber, or pipe, H, through the pipe, J.

The air that passes into the stove for the purpose of feeding the flame, passes upward through the holes, (c), in the disks, K, K, and by the position of these holes, is drawn nearer the chamber, or pipe, H, as it passes upward, and consequently serves to heat the air within the chamber, or pipe, H. The air last mentioned passes out of the stove at its upper part, and into a pipe, M, leading underneath the floor or into a flue. See solid arrows, Fig. 2.

The pumice stone, or asbestos, retains the heat, and prevents the formation of carbon, or lampblack, on the under surface of the copper bottom, I. To effect this perfectly, it is necessary that this bottom, I, be kept near the flame, as shown in Fig. 2, in order that it may be kept hot by it. No unpleasant odor escapes into the room as it passes into the pipe, M, at the upper part of the

body or case, as shown by the solid arrows.

With a stove of the above construction, having a single burner of ordinary capacity, a room, sixteen feet square, may be properly
5 heated. This has been proved by experiment.

I do not claim the perforated distributing disk, E, for that has been previously employed; neither do I claim placing pumice
10 stone, or other incombustible material in the flame, for retaining the heat, for that is well known. But

What I claim as new, and desire to secure by Letters Patent, is:—

The arrangement of the tube, D; hot air 15 chamber, H; and disks, K, K, as herein shown and described, and for the purpose as set forth.

ANDREW MAYER.

Witnesses:

H. C. MAYER,

STEPHEN K. SIMMONS.