

(19) AUSTRALIAN PATENT OFFICE

(54) Title
Eave lining system

(51) ⁶ International Patent Classification(s)
E04D 013/158 E04F 019/00

(21) Application No: 2004101018 (22) Application Date: 2004.11.29

(30) Priority Data

(31) Number	(32) Date	(33) Country
2004903567	2004.06.29	AU
2004903302	2004.06.17	AU
2003906615	2003.11.28	AU

20041223200508257

(43) Publication Date : 2004.12.23
(43) Publication Journal Date : 2004.12.23

(71) Applicant(s)
James Hardie International Finance B.V.

(72) Inventor(s)
Gleeson, James; Zarb, Joseph Emmanuel

(74) Agent/Attorney
Shelston IP, Level 21 60 Margaret Street, Sydney, NSW, 2000

ABSTRACT

An eave lining system for buildings including an eave lining sheet (1) pre-finished on at least one exposed surface and securing means for affixing the eave sheet to a support surface (6), wherein the eave sheet and securing means are configured such
5 that minimal post installation finishing is required.

In a preferred form, the system includes a pre-finished corner trim system for concealing and finishing the joint between the eave lining sheet and the adjacent building surface. In one form the trim system is a two-part system comprising an inner core element that is secured to the eave support structure or adjacent building surface,
10 and an outer pre-finished clip on cover element. Preferably, the cover element comprises standard straight length sections and custom pre-formed corner pieces that sit over the ends of the straight sections.

Figure 8

2004101018 29 Nov 2004

- 1 -

AUSTRALIA

PATENTS ACT 1990

COMPLETE SPECIFICATION

FOR AN INNOVATION PATENT

ORIGINAL

Name of Applicants: James Hardie International Finance B.V.

Actual Inventors: Joseph Emmanuel Zarb and James Gleeson

Address for Service is:

SHELSTON IP
60 Margaret Street Telephone No: (02) 9777 1111
SYDNEY NSW 2000 Facsimile No. (02) 9241 4666
CCN: 3710000352
Attorney Code: SW

Invention Title: EAVE LINING SYSTEM

Details of Associated Provisional Application No. 2003906615 dated 28 Nov 2003
2004903302 dated 17 Jun 2004
2004903567 dated 29 Jun 2004

The following statement is a full description of this invention, including the best method of performing it known to us :

File: 38578AUP00

500482400_1.DOC/5345

Technical Field

The present invention relates generally to building construction, and more particularly to the installation of eave linings.

Description of the Prior Art

5 The invention has been developed primarily for use in the installation of eave linings, and will be described predominantly with reference to this application. It will be appreciated, however, that the invention is not limited to this particular field of use, being also applicable to other areas of building and construction.

In the construction industry, the installation of eaves lining is a multi-stage
10 process. Eave sheet used to line the eaves is generally produced in set lengths and widths. The sheet must be transported to site, nailed into position on the building, the joints set, concealed or connected using joining strips and then the whole assembly must be painted. Sometimes, the sheet must be painted more than once with and undercoat and topcoat.

15 These finishing processes add greatly to the expense of installing eave linings adding labor and paint and setting costs as well as needing additional time taken to paint and/or set the eaves. In addition, eaves are most often situated high up on buildings and therefore, generally, additional costs for scaffolding equipment to elevate the tradesmen during the eave finishing and painting process will be incurred.

20 This is a particular problem in the construction of many project, kit and prefinished buildings where the only part of the entire building requiring painting are the eaves. Accordingly, painters must be brought in specifically and only for that task. As such the efficiency is reduced.

Another problem is the consistency of the painting when done onsite. It is often
25 the case that the coverage applied by hand painting eaves is not uniformly thick. This

2004101018 09 Aug 2005

- 2 -

may result in patchy protection and/or appearance. Similar comments apply in relation to the setting and concealing of various joints where this is required.

It is an object of the present invention to overcome or ameliorate one or more of these disadvantages of prior art, or at least to provide a useful alternative.

5 **Brief Summary of the Invention**

According to a first aspect, the invention provides an eave lining system for buildings including:

a fibre cement eave lining sheet pre-finished on at least one surface that will be exposed; and

10 securing means for affixing said eave sheet to a support surface; wherein said eave sheet and securing means are for pre-finished installation.

The term "pre-finished" is intended to cover all finishing processes and includes, but is not limited to, painting, coating, laminating (e.g. with Formica® or Tedlar®), as well as using pigmented base materials and/or additives so that no, or substantially no,

15 further finishing is required. The term may be used herein to describe not only the eave sheets, but also the entire eave system including the securing means for affixing the eave sheets and the eave trim system.

Desirably, the invention further includes a joining strip for joining a peripheral edge of said eave sheet with a peripheral edge of a like eave sheet; wherein said joining
20 strip is also preferably configured and coloured such that minimal post installation finishing is required.

The phrase "post installation finishing" is used herein to refer to any relevant post installation finishing process such as joint setting, painting and the like.

Preferably, the eave lining system also includes a pre-finished corner trim system
25 for concealing and finishing the joint between the eave lining sheet and the adjacent

2004101018 09 Aug 2005

- 3 -

building surface which in most cases is a wall. In a particularly preferred form, the trim system is a two-part system comprising an inner core element, that is secured to the eave support structure or adjacent building surface, and an outer pre-finished clip on cover element. Ideally, the cover element comprises standard straight length sections and custom pre-formed corner pieces. Desirably, the corner pieces sit over the straight section cover portions to allow for expansion and reduce the need for accurate length cuts on the long sections.

In one form, the inner core trim element has a conventional solid or hollow rectangular, quad, or fillet profile or the like, with rebates formed adjacent diametrically opposed corner edges for accepting in-turned lip portions on corresponding outer trim cover portions having the same general profile as the exposed portion of the inner element. For regular shaped profiles such as the square or rectangular trim element, and any other sections which could be installed in more than one orientation, rebates are formed on all edges or multiple sets of corner edges to reduce the need to carefully orientate the section prior to placement adjacent the joint.

In a second form, the inner core trim element has a thin walled profile defining only one or more surfaces for connection to the eave sheet or adjacent wall and means to secure thereto a cover element of the desired external profile. In one form the trim element has two perpendicular arms where the ends of each arm are configured to accept and retain outer trim portions having the same or a different general profile to the inner element.

Preferably, the securing means is selected from the group of screws, nails, staples, plugs, and glues and tapes and may include any combination thereof.

Preferably, the screws, nails and plugs are colour coordinated with the eave sheet or include colour coordinated caps.

2004101018 09 Aug 2005

- 4 -

In a preferred form particularly suited for use with externally clad timber framed building structures one or more components of the system such as the eave sheets, the sheet joining strips and/or the trim components, may include openings or perforations configured to provide a predetermined amount of ventilation to selected parts of the building structure such as the roof or wall cavities.

According to a second aspect of the invention there is provided a method of installing an eave lining system in accordance with any one of the previous aspects, said method including the steps of:

providing the fibre cement eave lining sheet, said sheet having at least one pre-finished surface; and

installing the eave lining sheet with the pre-finished surface exposed.

The first step may be conducted on or off site.

In preferred forms of the invention the method also includes the steps of securing the pre-finished eave sheets using some or all of the various securing and fixing elements of the second aspect of the invention.

According to a third aspect of the invention there is provided a two part trim system for concealing joints in building structures, said trim system including:

a base securable over or adjacent a joint to be concealed; and

a cover element connectable to said base to conceal said joint.

In various preferred forms the two part system is configured as per the embodiments foreshadowed and described herein with reference to an eaves corner joint which is defined by two intersecting planes. However, other variations are contemplated which are configured to conceal joints which occur in a single plane as may occur with cladding sheets and the like. In such embodiments the trim cover elements have

2004101018 09 Aug 2005

- 5 -

exposed external surfaces viewable over 180° rather than 90° as with the corner trim elements described herein.

Brief Description of the Drawings

A preferred embodiment of the invention will now be described, by way of example only, with reference to the accompanying drawings in which:

Figure 1 is a sectional side view of a building showing a first embodiment eave system in accordance with the invention;

Figure 2 is sectional plan view of the system shown in Fig. 1;

Figure 3a is a nail in accordance with the invention;

Figure 3b is a screw in accordance with the invention;

Figure 3c is a quick fix fastener plug in accordance with the invention;

Figure 4 is a view showing a first embodiment protective hammer pad in accordance with the invention;

Figure 5 is a view showing a second embodiment hammer protector cap in accordance with the invention;

Figure 6 is a sectional view of an abutment join "on frame" between two eave boards in accordance with the invention;

Figure 7 is a sectional view of an abutment join "off frame" between two eave boards in accordance with the invention;

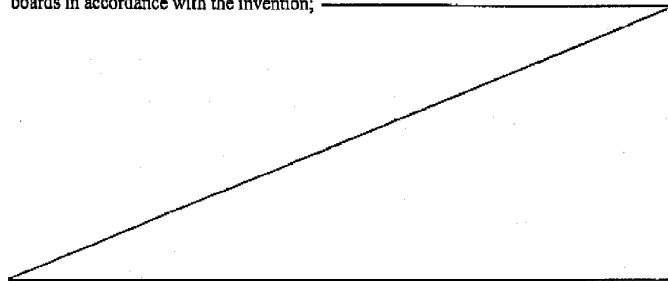

Figure 8 is a sectional side view of part of a building showing a second embodiment eave lining system in accordance with the invention having an alternative two part trim system;

Figure 9a shows a first embodiment straight inner trim section of the kind shown
5 in Figure 8;

Figure 9b shows an alternative embodiment straight inner trim section of the kind shown in Figure 8;

Figure 10 shows a first embodiment straight outer trim section for use with the inner trim section of Figure 9;

10 Figure 11 shows a partly assembled system using the inner and outer trim sections of Figures 9 and 10 along with a custom outer external corner piece;

Figure 12 shows a variety of alternative profiles for the two part trim system of Figures 8 to 11; and

Figure 13 shows a third embodiment eave lining system in accordance with the
15 invention that incorporates a vented eave panel and/or eave panel trim arrangement.

Figure 14 is a detailed view of the vented eave panel trim arrangement shown in Figure 13;

Figure 15 shows a ventilated eave panel end join strip particularly suited for, but not limited to use with the system of Figure 13.

20 **Detailed Description of the Invention**

In general terms the invention provides a pre-finished eave system for buildings such that post installation, no additional painting or finishing of the eaves is required.

In this embodiment, the eave sheets are fibre reinforced cement (FRC), classified as Type A Category 3 in accordance with AS/NZS 2908.2 'Cellulose-Cement Products'.

25 However, in alternative embodiments, the sheets may be of other suitable material. For

instance, it will be appreciated that sheets formed of (wood, metal or plastics etc) might replace the FRC sheets of this preferred embodiment and are within the scope of the invention.

Whichever material, the sheets are produced in a variety of standard widths and generally will be a standard thickness so that the sheets will be flush on installation. The table lists the preferred product sizes however, it will be appreciated that the product may be produced in any size or thickness as required.

Product Sizes		
Length (mm)	Width (mm)	Thickness (mm)
2400	450	4.5
2400	600	4.5
2400	750	4.5
2400	1200	4.5

The sheets may also be perforated through their thickness with a predetermined number and arrangement of slots or holes. These slots or holes provide a predetermined amount of airflow through the sheet, in turn providing ventilation to the roof or wall cavity when the sheet is installed.

In this embodiment, the sheets are pre-painted on at least one side with a protective paint or coating. Painting is normally an automated process conducted at a purpose built production facility and may be applied using conventional techniques, such as spraying, roll coating, curtain coating, or powder coating. The paint may be cured by thermal means or by radiation or a combination thereof. The paint may be applied in one or more coats with or without an undercoat layer, depending on the type and colour of paint or thickness of paint layer required.

The sheets may also be prefinished using durable laminates (e.g. Formica ® high pressure laminates) or durable polymeric films (e.g. Tedlar ® fluoropolymer films). Such laminates are applied to the surface of the sheet with a suitable adhesive, such as a

polyurethane adhesive. The sheets may also be coloured using organic or inorganic pigments incorporated directly into the fibercement. The sheets may also be coated with treatments to prevent the accumulation of mildew and fungus which may form during storage and when installed. Other possible coatings maybe applied to help fire retardation, repel insects or provide insulation characteristics. These coatings may be applied under or on top of the paint layer or may be additives to the paint itself.

While it is preferred that the sheets be painted in a factory and in a form which is substantially or totally pre-finished, it will be appreciated that the invention may be applied to sheets that are raw or unpainted and unfinished at purchase.

To prevent damage to the eaves during storage and shipment, the finished eave sheet may be prepared by covering the surfaces of the sheet with a one or more removable protective coatings or laminates. This process is described in detail by the applicant's corresponding, co-pending United States Application No. 10/620,711 filed 16 July, 2003. Alternatively, the removable protective coating may be spray-applied or applied as a transfer film from a backing material

The laminate forms a barrier preventing the surface of the eaves being damaged, marked or scratched. Once at the building site, the protective layer is stripped off either before, after or during installation. In one embodiment, the removable protective layer is preferably stripped after installation is complete, in order to protect the pre-finished panel surfaces from fingerprints, scratches and the like.

Referring to the drawings, as is known in the art, the eave sheets 1 are attached to the eaves support structure 4. As shown in Figures 1 and 2, the support structure 4 is generally a frame work of eave battens 4. These battens are most commonly steel or timber. In alternative embodiments, the eave sheets maybe attached to a substrate rather than the more common framework.

As can be seen in a first embodiment shown in Figure 1, the outer edge of each eave sheet fits into a groove 5 in an eave fascia board 6 and pre-finished trim 7 is used at the inner edge to fill the corner between the board and the exterior wall.

The trim can be a conventional wooden beading element, or instead could be an extruded plastic strip or similar, with or without pre-made straight section and/or corner connectors, the latter obviating the need to produce mitre cuts on site. Alternatively, a preferred two part trim system can be used as discussed below in reference to Figures 8 to 11. In either embodiment the trim may also be a fibrecement material.

In other embodiments such as maybe used in the US where grooves are not usually provided in the fascia board, the eaves sheet is nailed to a support and the fascia is installed afterwards. Any gap in the eaves sheet and the fascia is then caulked or covered by a trim piece which can be of the kinds discussed above.

The sheets are affixed to the supporting structure by a variety of methods. Such methods may include, nails 8, screws 9, plugs 10, staples, glues or adhesive tapes alone or in combination. However, it is preferable that the fixing method and procedure does not damage the eave board surface so that the need for any painting or touch up painting after installation is eliminated or kept to a minimum.

For instance, screws and nails are fitted with coloured or painted heads to match the eave board finish. Accordingly, as shown in Figure 4 special hammer pads 11 are provided so that the heads of the nails are not marked and the sheet not damaged. In an alternative embodiment shown in Figure 5, a soft plastic or rubber hammer protective cap 11a is provided along with a sleeve 11b that allows the protective cap to be fitted to hammers having a smaller head size. Another method is to use coloured caps in conjunction with screws and nails to cover the exposed head. Touch up may be required

if non-prefinished fixers are used e.g. when stainless steel nails are specified in coastal areas.

As seen in Figures 6, 7, and 15, joining strips 12 are provided to facilitate joining of abutting boards. The joining strips may be extruded plastic or another suitable material such as timber, rubber or a molded material. Preferably, the strips are colour coordinated with the boards and do not require painting. The strips may be used for joints between sheets either on frame as shown in Figure 6 or off frame as shown in Figure 7. Alternatively, a strip may be pre-attached to one sheet with a suitable adhesive. While these strips are of a generally "H" shaped profile, typically one internal leg is extended to facilitate attachment to the support structure as shown in Figure 6. H-moulds may have an extended width and contain perforations to provide venting as per the example shown in Figure 15.

Referring next to Figures 8 to 11, there is shown an alternative and preferred two part trim system for finishing and concealing the corner between the eave sheets and the adjacent wall. This system uses an inner trim section which in the form illustrated in Figure 9a shows a first embodiment comprising a solid elongate core member 13a of generally rectangular section, having rebates 14 adjacent to diametrically opposed corner edges as shown. An alternative embodiment 13b is shown in Figure 9b which has rebate on all four edges so that the section can be installed in multiple orientations thereby simplifying the installation process. This modification can be applied to any profile that could be installed in more than one configuration. These inner trim cores can be made of wood or a wood based composite like most of the conventional beadings and trim sections used in the building industry. However, any other firm nailable material would be suitable including, for example, polymeric expanded foam materials or the like.

In other forms (not illustrated), the core element may be of a simple thin walled structure effectively defining a base plate which can be secured to the eave sheet and/or the adjacent building surface and which includes retaining means to which a clip on cover can be connected. Such a base plate may be of a standard generally L shaped section and it is each cover element only which is configured to the desired external profile.

The second part of the system comprises a pre-finished outer cover element 15a that is adapted to sit over the inner core element 13. In the example provided, the outer core at a cover element has in-turned lip formations 16 along its outer edges, such that the cover 15 can be "snapped on" to the core element and be retained thereby engagement of the lip formations 16 with the corresponding rebates 14. This cover element can again be made of any material that would provide a requisite resilience to effect a simple "snap-on" or "push-on" connection. Suitable materials may include various moulded or extruded polymers or pre-coated steel or aluminum sections.

Also, optionally forming part of the cover element portion of this trim system are pre-formed and pre-finished corner pieces such as 15b shown in Figure 11. The corner pieces can be made available in all common configurations such as 90° (internal and external) and 135° external for bay windows and the like. Preferably, the custom corner sections are configured to sit over the straight section cover elements. This eliminates the need for accurate length cutting on the long sections and allows for expansion and contraction which can be a problem over long lengths.

The advantages of the two part inner and outer trim system are significant, in that the need for a skilled carpenter is eliminated and a simplified fixing process should be fairly quick to install. In this regard, the inner core sections can be conveniently cut using, for example, suitable plier type cutters and nailed into position without the need to

ensure a clean and accurate mitre join at the corner. The straight section cover elements can then be cut approximately to length in the same way and “snapped” onto the core elements. Finally, the corner pieces can be clipped on top of the adjacent straight section cover portions and the finishing processes complete. There is no need to finish
5 or touch up joints, and no special skills are required as there are no mitre joints to be cut and accurate length cutting at the straight sections is not needed.

As can be seen from Figure 12, the two part inner and outer trim system can be configured to any desired profile and is not limited to the examples shown, nor is it limited to the use of solid core elements as shown in this illustration. Additional
10 advantages are that the hidden fixings of the 2 part trim section removes the need for touch up of nails or screws. Furthermore the snap on trim sections allow for thermal expansion of the building and the eaves components that is not possible using a 1 piece trim as is found in traditional eaves installation methods. This ability to accommodate thermal expansion provides a significant advantage over prior art systems. For example,
15 for a fully fixed trim that can't accommodate thermal expansion, buckling of the trim can occur if the thermal expansion of the trim is greater than the wall resulting in an unsightly finish and possible nail pull out of the trim. Alternatively, if the wall/substrate/etc expands more than a fully fixed trim, the corner joints of the trim can open up and cause a deterioration in performance of the eaves system. These potential
20 problems are avoided with the preferred system described above.

It will also be appreciated that while this two part trim system is particularly suited to use in eave lining systems as described, it is equally applicable to other building applications where corner or indeed planar joints need to be concealed in a simple manner that minimises the need for highly skilled labour.

Turning finally to Figures 13, 14 and 15 there are shown further variations to the invention that incorporate venting means for enabling air and moisture vapour to flow from the wall and/or roof cavity to atmosphere. The arrangement shown in the accompanying figures is particularly well suited to externally clad timber frame structures. However, the concept is not limited to this particular type of building structure.

In order to provide ventilation to the wall cavity, a vented trim system is optionally provided. While the illustrated form is based on the preferred two part trim system, an equivalent single part trim component could also be used. The functional modification resides in the provision of a trim wall extension strip 17 which has ventilation apertures 18 provided therein.

In use, the vented eaves sheets are secured in the usual manner and an opening 19 is left between the external wall cladding and the sheet and/or eaves bearer. The modified trim element including the trim wall extension strip 17 is then secured to the eave sheet so that the extension strip bridges over the opening 19 as shown. If separate or additional ventilation is required into the roof cavity, then a suitably vented eaves sheet can also be used. Alternately, a roof space may be ventilated by using a similar strip and re-orienting it so that the vented extension strip bridges a gap between the eaves sheet and the eaves support structure. The eaves sheets, whether ventilated or un-ventilated, can also be joined using a ventilated end join strip 12 such as the kind shown in figure 15 which further enhances the ventilation and also provides an easy means of providing ventilation without using perforated eave panels which may not be aesthetically acceptable.

It will be appreciated that all aspects of the invention provide significant advantages over the prior art by minimising or at least significantly reducing the amount

of time consuming and expensive in-situ post installation finishing required. This enables faster and more economical installation of eaves, particularly where scaffolding would have normally been required. Furthermore, the trim arrangement incorporating overlapping corner and end finishing components overcomes problems that can readily occur with fixed trim systems where there is some form of differential expansion between the trim and the adjacent sheets or elements of the building structure.

Although the invention has been described with reference to specific examples it will be appreciated by those skilled in the art that the invention may be embodied in many other forms.

2004101018 09 Aug 2005

THE CLAIMS DEFINING THE INVENTION ARE AS FOLLOWS:-

- 1. An eave lining system for buildings including:
a fibre cement eave lining sheet pre-finished on at least one surface that will be exposed after installation; and
- 5 securing means for affixing said eave sheet to a support surface;
wherein said eave sheet and securing means are configured for pre-finished installation.
- 2. An eave lining system for buildings according to claim 1 including a pre-finished corner trim system for concealing and finishing a joint between an eave lining and an adjacent building surface.
- 10 3. An eave lining system according to claim 2, wherein the trim system is a two-part system comprising an inner core element that is secured to an eaves support structure or adjacent building surface, and an outer pre-finished clip-on cover element.
- 15 4. An eave lining system for buildings according to any one of the preceding claims substantially as herein described with reference to any one of the embodiments of the invention illustrated in the accompanying drawings and/or examples.
- 5. A method of installing an eave lining system in accordance with any one of the preceding claims, said method including the steps of:
providing the fibre cement eave lining sheet, said sheet having at least one pre-
20 finished surface; and
installing the eave lining sheet with the pre-finished surface exposed.

DATED this 9th day of August, 2005
 SHELSTON IP
 Attorneys for: JAMES HARDIE INTERNATIONAL FINANCE B.V.

25

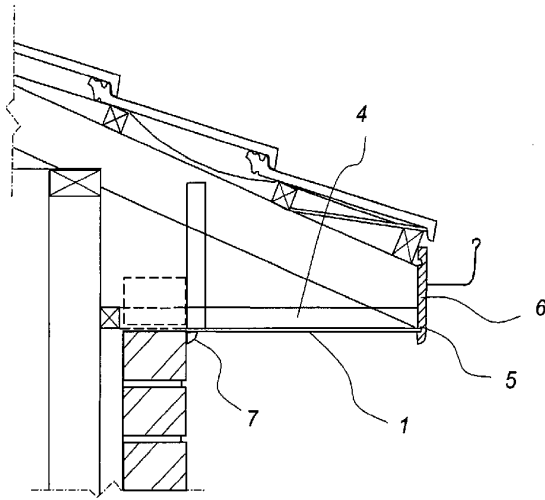

Fig. 1

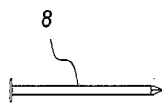

Fig. 3a

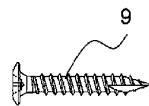

Fig. 3b

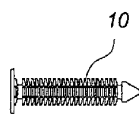

Fig. 3c

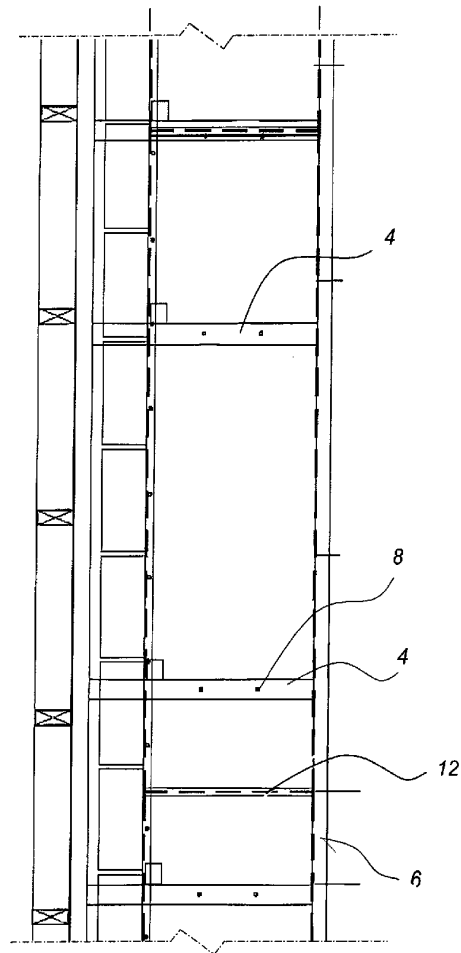

Fig. 2

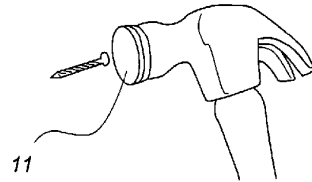

Fig. 4

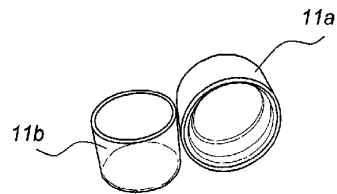

Fig. 5

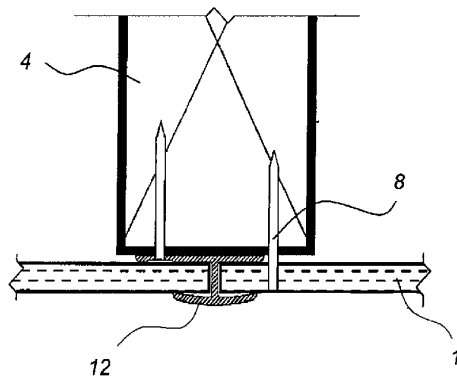

Fig. 6

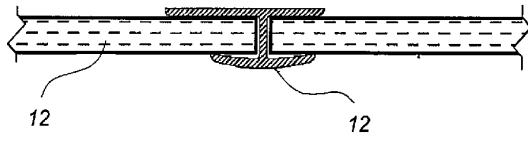

Fig. 7

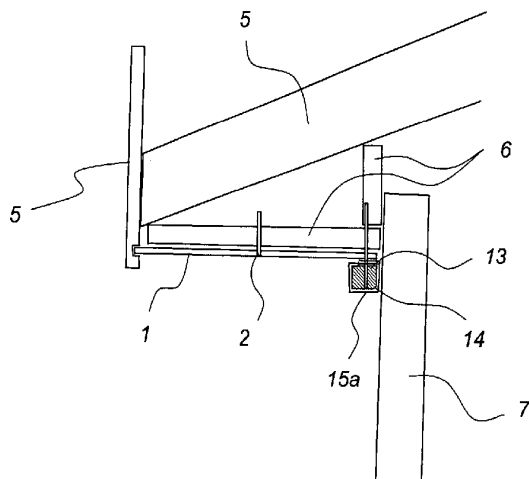
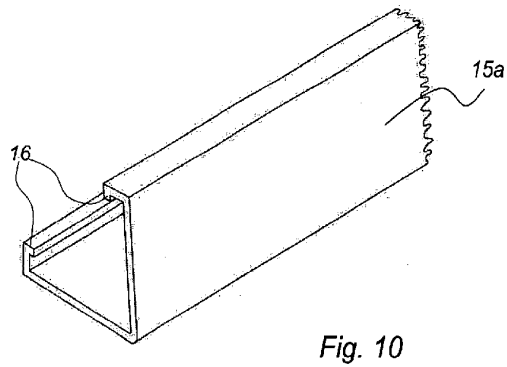
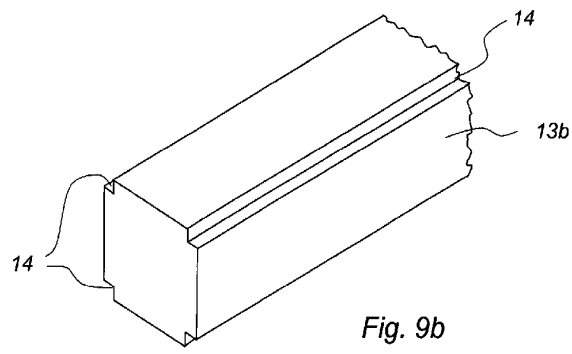
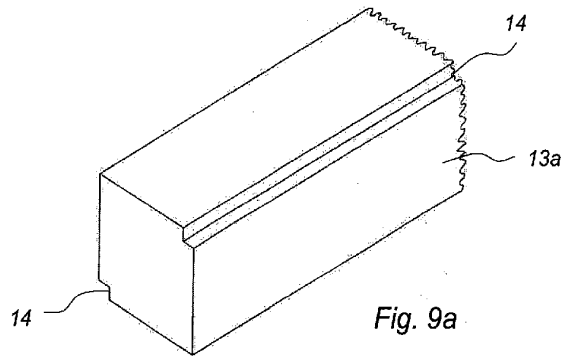

Fig. 8



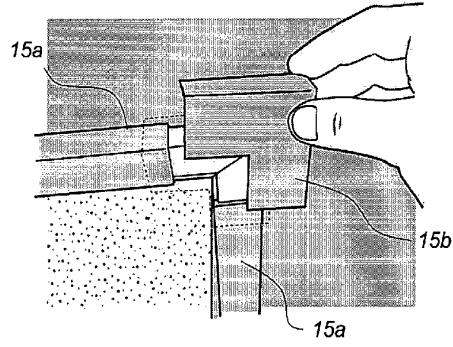

Fig. 11

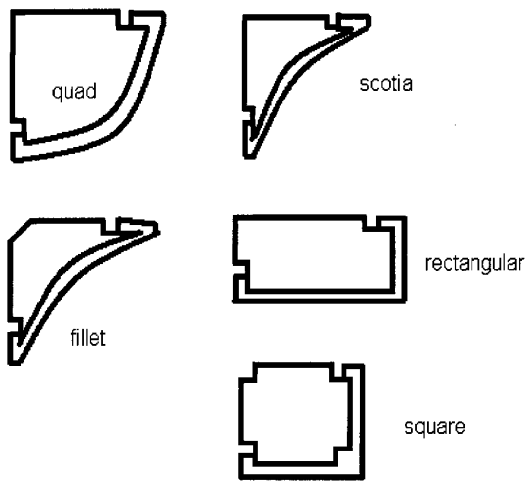

Fig. 12

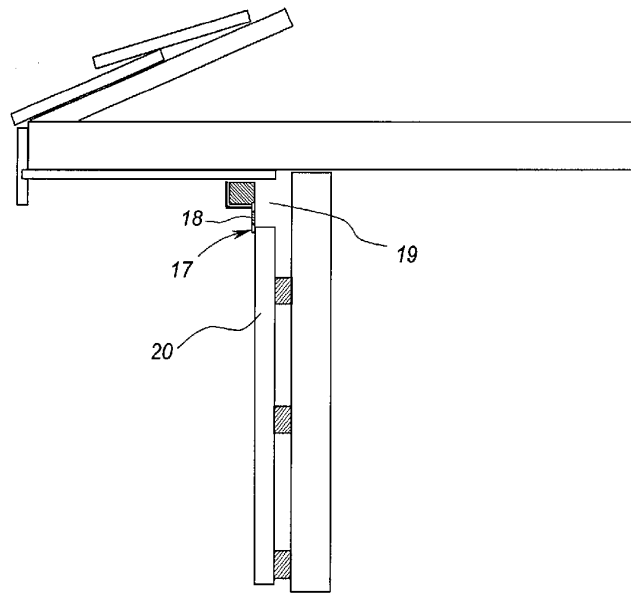

Fig. 13

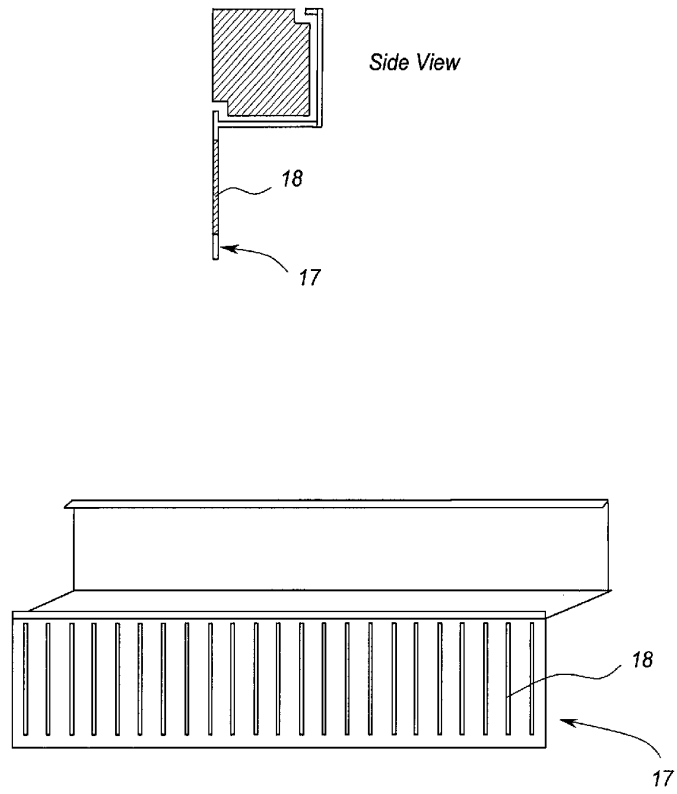

Fig. 14

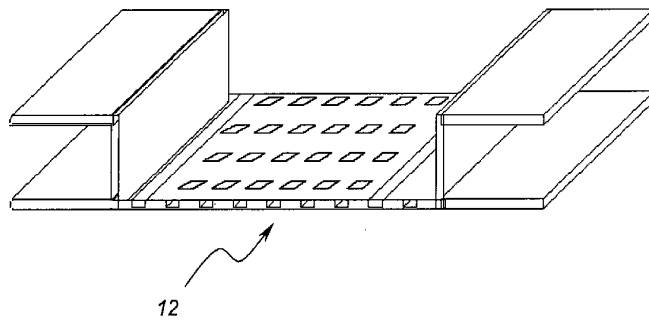

Fig. 15