

June 3, 1924.

1,496,580

F. KUSTERLE

BOTTOM MOUNT

Filed Sept. 22, 1920

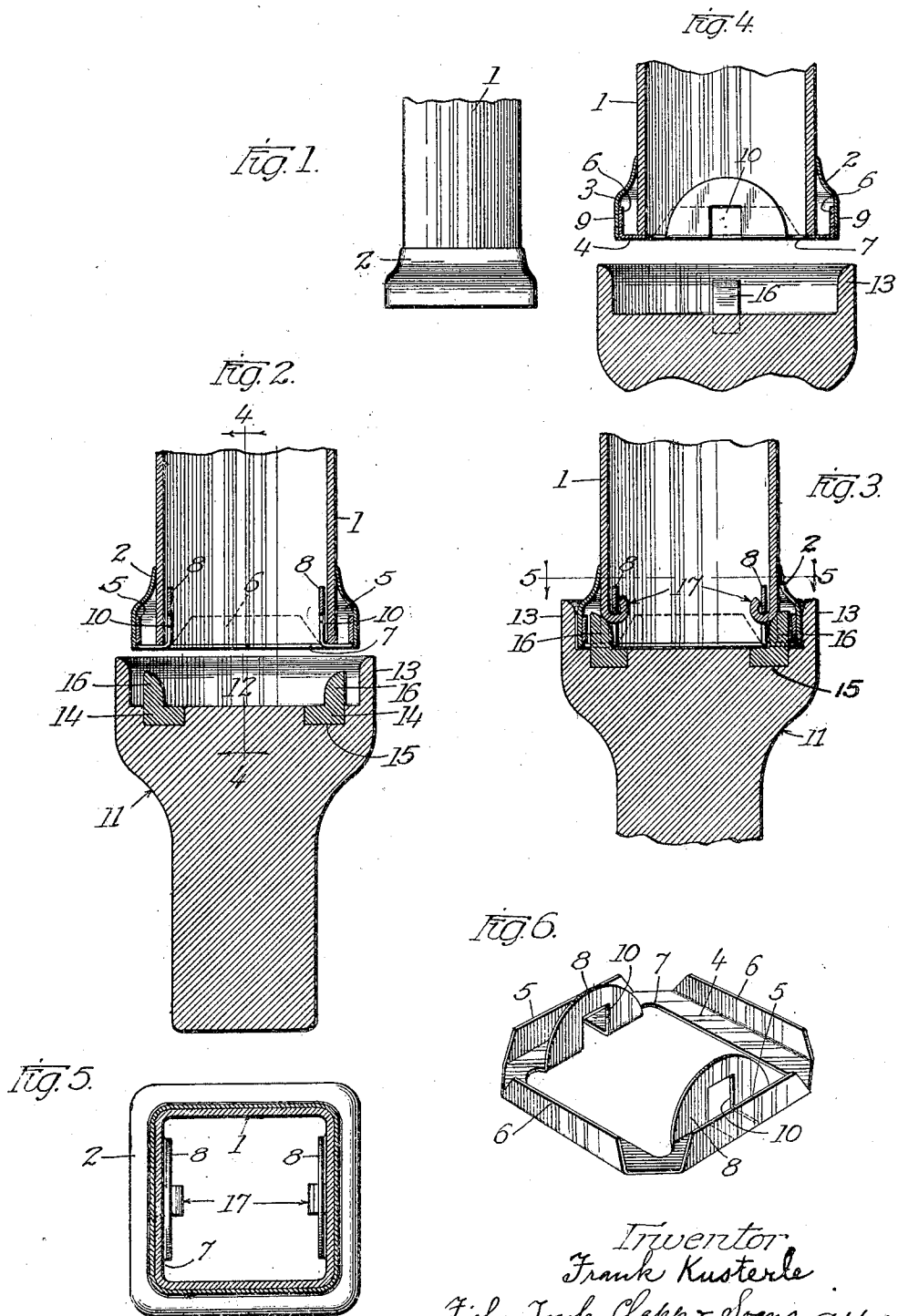

Inventor
Frank Kusterle
Fisher Towle Clapp & Soans, Attys.

UNITED STATES PATENT OFFICE.

FRANK KUSTERLE, OF KENOSHA, WISCONSIN, ASSIGNOR TO SIMMONS COMPANY, OF KENOSHA, WISCONSIN, A CORPORATION OF WISCONSIN.

BOTTOM MOUNT.

Application filed September 22, 1920. Serial No. 412,090.

To all whom it may concern:

Be it known that I, FRANK KUSTERLE, a citizen of the United States, residing in the city of Kenosha, in the county of Kenosha and State of Wisconsin, have invented certain new and useful Improvements in Bottom Mounts, of which the following is a specification.

My invention has reference to an end fitting for a tubular member, as for example a bottom mount for the lower end of a bed post, and also has reference to the method of attaching same thereto.

In constructing articles wherein a tubular part is used, it is often desirable to employ a fitting on the end of the tubular part for reinforcing and affording a finished appearance thereto, or to provide substantial means for attaching other parts to the tubular member, and my invention seeks to provide an improved fitting of this character and facilitate the attachment thereof to the tubular part.

The principal objects of my invention are to provide an improved end fitting for a tubular member; to provide a novel method of attaching same; to attach the end fitting by bending a portion of the tube so as to interlock with the fitting; to construct the fitting so as to co-operate with a tool in shearing off a tongue for effecting the attachment; to provide an improved fitting which is particularly adapted to serve as a bottom mount for a bed post; and in general, to provide an improved end fitting for a tubular post, which is economical to manufacture and may be conveniently and quickly attached without the necessity of employing separate attaching parts, such as bolts or rivets.

On the drawings:

Fig. 1, is a fragmentary view of the end of a tubular post with my end fitting thereon;

Fig. 2, a vertical sectional view of my improved fitting, placed in position to be attached to the end of the post, and shows the tool positioned ready to effect the attachment;

Fig. 3, a similar view showing the tool in the position at the end of the operation of attaching the fitting to the post;

Fig. 4, a sectional view on the line 4—4 of Fig. 2;

Fig. 5, a transverse sectional view on the line 5—5 of Fig. 3; and

Fig. 6, a perspective view of the abutment and shearing plate which forms a part of my attachment.

Referring to the drawings, the reference numeral 1 indicates a portion of the end of a tube, as for example, a tubular bed post, which may be of any form although it is indicated in rectangular cross section on the drawing, and 2 indicates as a whole, the end fitting, which comprises the flared shell 3 and the bottom plate 4, against which the end of the post is butted.

The shell 3 is restricted at its upper end so as to telescope snugly on the end of the post 1, and is expanded at the lower end to form a bottom mount of desirable appearance, and also to accommodate flanges of the bottom or abutment plate therein. This bottom or abutment plate 4 is of rectangular skeleton form, and provided with upturned flanges 5—5 and 6—6 which are inserted within the shell 3 to such an extent that the bottom of the plate 4 is flush with the lower edge of the shell 3. This plate is cut away at the center as at 7, and formed at opposite sides of this opening 7 with upturned ears 8, spaced apart a suitable distance to fit somewhat closely within the end of the tube 1, to which they are attached. The bottom plate 4 is secured in the shell 3 in any suitable manner, as for example, by spot welding the flanges 6 to the sides of the shell 3, as indicated at 9 in Fig. 4.

For attaching the fitting 2 to the post 1, each of the ears 8 is formed with a slot 10 extending upwardly, as shown in Fig. 6, which slots co-operate with a tool to shear off a tongue which is curled up against the upper edge of the slot, and these slots extend laterally in the bottom plate 4 to the upturned flanges 5, as shown, to admit projections of the tool for shearing off and curling up the attaching tongues.

To attach the fitting to the post, I use a tool 11, having a rectangular socket 12 in the end to receive the end of the post and the fitting therein, and I bevel or round off the inner edge of the flange 13, which surrounds the socket, to facilitate inserting the tool onto the end of the post. This tool is provided in the bottom of the socket 12 with

a pair of spaced dies 14, which are secured in any convenient manner in the die seats 15, and these dies have projections 16 of suitable width and rounded on their inner faces and spaced apart a suitable distance, so that when the tool 11 is forced against the lower end of the post and the fitting thereon, the projections 16 enter the slots 10 outside the wall of the tube 1, and co-operating with the slots 10, shear off a tongue member 17 at each side of the tube, which tongues owing to the form of the inner faces of the projections 16, are curled up tight against the upper edges of the slots 10, as indicated in Fig. 3, and secure the fitting 2 firmly onto the lower end of the post.

It is to be understood that the post 1 and the tool 11 are pressed firmly together in any convenient manner to effect the attachment, and it is merely necessary to insert the fitting 2 onto the end of the post and apply the tool to effect a secure attachment.

While I have shown and described my invention in a preferred form, I am aware that various changes and modifications may be made without departing from the principles of my invention, the scope of which is to be determined by the appended claims.

I claim as my invention:

1. The combination of a tube and an end fitting therefor having overlapping portions, and an integral hook on one of said portions turned back thereover and engaging the other of said portions to lock the tube and fitting together.

2. The combination with a tube, of an end fitting therefor comprising a member against which the end of the tube is butted, said member having apertured portions overlapping the wall of the tube, and laterally bent portions of the tube engaged in the apertures at a distance from the end of the tube so as to lock the fitting onto the end of the tube.

3. The combination with a tube, of an end fitting therefor comprising an abutment

plate with a shell surrounding the end of the tube, ears on the abutment plate inserted inside the tube, and integral tongues cut from the tube and concealed by the shell and interlocked with the said ears for locking the end fitting onto the tube.

4. The combination with a tube, of an end fitting therefor comprising a plate against which the end of the tube is butted, said plate having parts thereon extending along opposite sides of the wall of the tube, openings in the positions within the tube, and tongues cut from the tube and bent inwardly so as to engage said openings and thereby lock the fitting onto the end of the tube.

5. The combination with a tube, of a fitting telescoped onto the end of the tube and having an apertured portion lying adjacent the inner face of the tube, and a tongue cut from the tube and bent inwardly so as to engage the aperture of said portion and thereby lock the fitting onto the end of the tube.

6. The combination with a tube, of a fitting telescoped onto the end of the tube and provided with a portion having a shearing opening adjacent the surface of the tube wall, and a locking member sheared from the tube by forcing a portion of the tube through the shearing opening, said locking member being bent so as to interlock with the shearing opening and thereby lock the fitting onto the end of the tube.

7. The combination with a tubular post, of a bottom mount therefor comprising a shell telescoped onto the end of the post and provided with an inwardly extending flange forming an abutment against which the end of the tube is engaged, a plurality of extensions on the inturned flange projecting along the inner face of the post and having openings therein, and a strip cut from the end of the post adjacent each slot and bent inwardly therethrough, so as to lock the bottom mount onto the end of the post.

FRANK KUSTERLE.