



- (51) **International Patent Classification:**
H01M 8/04 (2006.01)
- (21) **International Application Number:**
PCT/IB2012/051174
- (22) **International Filing Date:**
13 March 2012 (13.03.2012)
- (25) **Filing Language:** English
- (26) **Publication Language:** English
- (30) **Priority Data:**
863/MUM/2011 23 March 2011 (23.03.2011) IN
- (71) **Applicant (for all designated States except US):** **TATA MOTORS LIMITED** [IN/IN]; Bombay House, 24 Homi Mody Street, Hutatma Chowk, Mumbai 400 001, Maharashtra (IN).
- (72) **Inventors; and**
- (75) **Inventors/Applicants (for US only):** **DHIRAJLAL, Bhut, Bhaveshkumar** [IN/IN]; c/o Tata Motors Limited, Bombay House, 24 Homi Mody Street, Hutatma Chowk, Mumbai 400 001 Maharashtra (IN). **MATH, Somalingayya, Gurupadayya** [IN/IN]; c/o Tata Motors Limited, Bombay House, 24 Homi Mody Street, Hutatma Chowk, Mumbai 400 001 Maharashtra (IN). **ANNEGOWDA, Yogesha, Sankenhalli** [IN/IN]; c/o Tata Motors Limited, Bombay

House, 24 Homi Mody Street, Hutatma Chowk, Mumbai 400 001 Maharashtra (IN). **MUNUSAMY, Raja** [IN/IN]; c/o Tata Motors Limited, Bombay House, 24 Homi Mody Street, Hutatma Chowk, Mumbai 400 001 Maharashtra (IN).

(74) **Agents:** **THIPPAPPA, Madhusudan, Siddara** et al.; K & S Partners, # 4121/B, 6th Cross, 19A Main HAL II, Stage (Extension), Bangalore 560 038 (IN).

(81) **Designated States (unless otherwise indicated, for every kind of national protection available):** AE, AG, AL, AM, AO, AT, AU, AZ, BA, BB, BG, BH, BR, BW, BY, BZ, CA, CH, CL, CN, CO, CR, CU, CZ, DE, DK, DM, DO, DZ, EC, EE, EG, ES, FI, GB, GD, GE, GH, GM, GT, HN, HR, HU, ID, IL, IN, IS, JP, KE, KG, KM, KN, KP, KR, KZ, LA, LC, LK, LR, LS, LT, LU, LY, MA, MD, ME, MG, MK, MN, MW, MX, MY, MZ, NA, NG, NI, NO, NZ, OM, PE, PG, PH, PL, PT, QA, RO, RS, RU, RW, SC, SD, SE, SG, SK, SL, SM, ST, SV, SY, TH, TJ, TM, TN, TR, TT, TZ, UA, UG, US, UZ, VC, VN, ZA, ZM, ZW.

(84) **Designated States (unless otherwise indicated, for every kind of regional protection available):** ARIPO (BW, GH, GM, KE, LR, LS, MW, MZ, NA, RW, SD, SL, SZ, TZ, UG, ZM, ZW), Eurasian (AM, AZ, BY, KG, KZ, MD, RU, TJ, TM), European (AL, AT, BE, BG, CH, CY, CZ, DE, DK, EE, ES, FI, FR, GB, GR, HR, HU, IE, IS, IT, LT, LU, LV, MC, MK, MT, NL, NO, PL, PT, RO, RS, SE, SI, SK,

[Continued on next page]

(54) **Title:** A SYSTEM AND METHOD FOR RECIRCULATING HYDROGEN AND BLEEDING OF IMPURITIES FROM FUEL CELL STACK

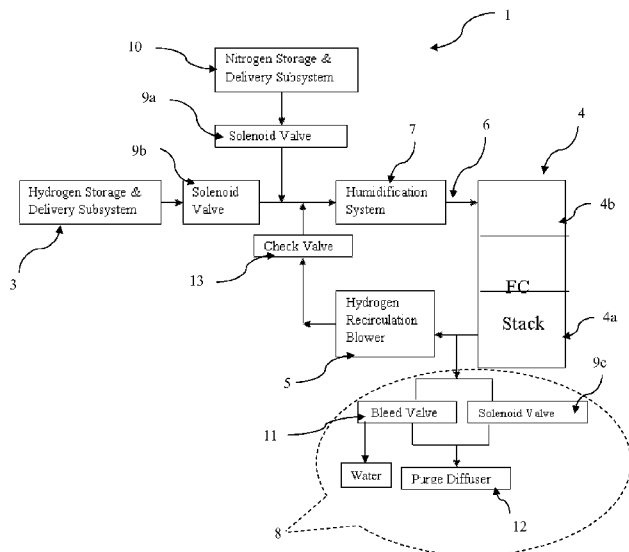

FIG. 1

(57) **Abstract:** The present disclosure provides a system for recirculating hydrogen and bleeding of impurities in hydrogen subsystem of polymer electrolyte fuel cell of a vehicle, said system comprises; an electronic control unit of the vehicle, a hydrogen storage and delivery subsystem interfaced with the electronic control unit to store and supply the hydrogen to a fuel cell stack through a solenoid valve and a humidification system; a hydrogen recirculation blower connected to the fuel cell stack and a hydrogen circulation line; a nitrogen storage and delivery sub system interfaced with the electronic control unit to store and supply the nitrogen to a fuel cell stack through a solenoid valve and the humidification system; a hydrogen purging and diffusing system provided in between the fuel cell stack and hydrogen recirculation blower, wherein said hydrogen purging and diffusing system facilities removal of condensed water and other impurities from the fuel cell stack.

WO 2012/127361 A1

SM, TR), OAPI (BF, BJ, CF, CG, CI, CM, GA, GN, GQ, GW, ML, MR, NE, SN, TD, TG). **Published:**

Declarations under Rule 4.17:

- *as to the applicant's entitlement to claim the priority of the earlier application (Rule 4.17(iii))*
- *of inventorship (Rule 4.17(iv))*

- *with international search report (Art. 21(3))*
- *before the expiration of the time limit for amending the claims and to be republished in the event of receipt of amendments (Rule 48.2(h))*

A SYSTEM AND METHOD FOR RECIRCULATING HYDROGEN AND BLEEDING OF IMPURITIES FROM FUEL CELL STACK

5 TECHNICAL FIELD

Embodiments of the present disclosure relates to a fuel cell of a vehicle. More particularly, embodiments relates to a system and method for recirculating hydrogen and bleeding of impurities in hydrogen subsystem of polymer electrolyte fuel cell of the vehicle.

10

BACKGROUND OF DISCLOSURE

Fuel cell is defined as an electrochemical cell that directly converts chemical energy of a fuel into electrical energy. Unlike a conventional battery, the fuel cell can continuously produce electricity as long as the fuel and air are supplied thereto. Hydrogen is used as the fuel of the fuel cell includes pure hydrogen and reformed hydrogen produced by a reforming process using a hydrocarbon such as methane or ethanol. Although the pure oxygen improves efficiency of the fuel cell, there may be a problem that additional cost and undesirable increase of weight are entailed for providing a tank for the pure oxygen.

20

In the fuel cell system more hydrogen is supplied than the stoichiometric ratio to the anode compartment of the fuel cell stack to prevent fuel cell stack for starving of hydrogen. During operation of fuel cell stack, hydrogen consumed and there is condensation water vapour to liquid water and also accumulation of inert gases like nitrogen as impurities which needs to be purged continuously or periodically. There is also requirement for recirculation of excess hydrogen in the anode compartment to the fuel cell stack.

Further, the condensed water from anode and water flooded from electrode which had crossed over from cathode to anode due to concentration gradient needs to be purged out periodically at regular intervals. And purging is also required to remove the accumulated of impurities like inert gases like nitrogen during the generation and compression and

30

dispensing of hydrogen. There is also purging requirement during startup for removal of entrapped air and also flushing out of hydrogen from anode during emergency shutdown.

In light of forgoing discussion, it is necessary to develop a system and method for
5 recirculation of hydrogen and bleeding of impurities in hydrogen subsystem of polymer electrolyte fuel cell.

STATEMENT OF THE DISCLOSURE

10 Accordingly, the present disclosure provides a system (1) for recirculating hydrogen and bleeding of impurities in hydrogen subsystem of polymer electrolyte fuel cell of a vehicle, said system comprises; an electronic control unit (2) of the vehicle, a hydrogen storage and delivery subsystem (3) interfaced with the electronic control unit (2) to store and supply the hydrogen to a fuel cell stack (4) through a solenoid valve (9b) and a humidification
15 system (7); a hydrogen recirculation blower (5) connected to the fuel cell stack (4) and a hydrogen circulation line (6); a nitrogen storage and delivery sub system (10) interfaced with the electronic control unit (2) to store and supply the nitrogen to a fuel cell stack (4) through a solenoid valve (9a) and the humidification system (7); and a hydrogen purging and diffusing system (8) provided in between the fuel cell stack (4) hydrogen recirculation
20 blower (5), wherein said hydrogen purging and diffusing system (8) facilitates removal of condensed water and other impurities from the fuel cell stack (4), and also provides for a method for recirculating hydrogen and bleeding of impurities in hydrogen subsystem of polymer electrolyte fuel cell of a vehicle, said method comprising acts of; checking a mode of operation of a vehicle by means of driver input; wherein said mode comprises startup
25 mode, run mode, emergency mode and shut down mode; opening a solenoid valves (9a and 9c) to flush out entrapped air from a fuel cell stack (4) when start up time measured by an electronic control unit (2) during the startup mode is less than preset time limit; opening a solenoid valves (9b and 9c) when the start up time is more than the preset limit and voltage of fuel stack (4) measured by the electronic control unit (2) is less than preset voltage limit
30 to supply hydrogen to a fuel cell stack (4) to prevent starvation of hydrogen during the run mode; and opening the solenoid valves (9a and 9c) flush out hydrogen from a fuel cell

stack (4) when a temperature of the stack (4) measured by the electronic control unit (2) during the shutdown mode is less than preset temperature level; wherein an excess hydrogen is recirculated from a fuel cell stack (4) through a humidification system (7) using a hydrogen recirculation blower (5) for improving an efficacy of hydrogen.

5

SUMMARY OF THE DISCLOSURE

The shortcomings of the prior art are overcome and additional advantages are provided through the provision of a system and method as claimed in the present disclosure.

10

Additional features and advantages are realized through the techniques of the present disclosure. Other embodiments and aspects of the disclosure are described in detail herein and are considered a part of the claimed disclosure.

15

One embodiment of the present disclosure provides a system (1) for recirculating hydrogen and bleeding of impurities in hydrogen subsystem of polymer electrolyte fuel cell of a vehicle. The system (1) comprises an electronic control unit (2) of the vehicle. The system (1) further includes hydrogen storage and delivery subsystem (3) which is interfaced with the electronic control unit (2) to store and supply the hydrogen to a fuel cell stack (4) through a solenoid valve (9b) and a humidification system (7). A hydrogen recirculation blower (5) connected to the fuel cell stack (4) and a hydrogen circulation line (6). A nitrogen storage and delivery sub system (10) interfaced with the electronic control unit (2) to store and supply the nitrogen to a fuel cell stack (4) through a solenoid valve (9a) and the humidification system (7). And a hydrogen purging and diffusing system (8) provided in between the fuel cell stack (4) and hydrogen recirculation blower (5), wherein said hydrogen purging and diffusing system (8) facilitates removal of condensed water and other impurities from the fuel cell stack (4).

20

25

30

In one embodiment of the present disclosure, the hydrogen purging and diffusing system (8) comprises a bleed valve (11) for removing the condensed water and solenoid valve (9c)

for removing the accumulated impurities in the fuel cell stack (4) through a purge diffuser (12) with fan.

5 In one embodiment of the present disclosure, a check valve (13) is provided in between the hydrogen recirculation blower (5) and the hydrogen circulation line (6) to increase the pressure of recirculating hydrogen and to allow the unidirectional flow of the recirculating hydrogen.

10 Another embodiment of the present disclosure provides a method for recirculating hydrogen and bleeding of impurities in hydrogen subsystem of polymer electrolyte fuel cell of a vehicle. The said method comprises acts of; checking a mode of operation of a vehicle by means of driver input. The operation mode comprises startup mode, run mode, emergency mode and shut down mode. Now, opening a solenoid valves (9a and 9c) to flush out entrapped air from a fuel cell stack (4) when start up time measured by an
15 electronic control unit (2) during the startup mode is less than preset time limit. Then, opening a solenoid valves (9b and 9c) when the start up time is more than the preset limit and voltage of fuel stack (4) measured by the electronic control unit (2) is less than preset voltage limit to supply hydrogen to a fuel cell stack (4) to prevent starvation of hydrogen during the run mode. And opening the solenoid valves (9a and 9c) to flush out hydrogen
20 from a fuel cell stack (4) when a temperature of the stack (4) measured by the electronic control unit (2) during the shutdown mode is less than preset temperature level. The excess hydrogen is recirculated from a fuel cell stack (4) through a humidification system (7) using a hydrogen recirculation blower (5) for improving an efficacy of hydrogen.

25 In one embodiment of the present disclosure, opening of solenoid valve (9a and 9c) to flush out hydrogen from the fuel cell stack (4) during the emergency mode.

The foregoing summary is illustrative only and is not intended to be in any way limiting. In addition to the illustrative aspects, embodiments, and features described above, further
30 aspects, embodiments, and features will become apparent by reference to the drawings and the following detailed description.

OBJECTIVES OF THE DISCLOSURE

5 One object of the present disclosure is to regulate the flow of hydrogen to a fuel cell stack as per power demand of the vehicle.

One object of the present disclosure is to provide a system for recirculation excess hydrogen present in the anode compartment of the fuel cell stack.

10 One object of the present disclosure is to provide a system for bleeding condensed water and impurities in hydrogen subsystem of fuel cell.

One object of the present disclosure is to provide a system for flush out hydrogen from the fuel cell stack during emergency and shutdown of vehicle.

15 One object of the present disclosure is to provide a system to supply correct amount of hydrogen to a fuel cell stack to prevent starvation of hydrogen in the fuel cell stack.

20 One object of the present disclosure is to provide a system which supplies hydrogen to the fuel cell stack at correct state i.e. temperature, pressure and humidity.

BRIEF DESCRIPTION OF THE ACCOMPANYING FIGURES

The novel features and characteristic of the disclosure are set forth in the appended claims.

25 The disclosure itself, however, as well as a preferred mode of use, further objectives and advantages thereof, will best be understood by reference to the following detailed description of an illustrative embodiment when read in conjunction with the accompanying figures. One or more embodiments are now described, by way of example only, with reference to the accompanying figures wherein like reference numerals represent like
30 elements and in which:

FIG.1 illustrates a system for recirculation and hydrogen and bleeding of impurities in hydrogen subsystem.

FIG. 2 illustrates a block diagram showing interface of Electronic Control Unit with the solenoid valves and other subsystems to monitor different parameters.

5 FIG. 3 illustrates a flow chart to monitor different parameters of the system for recirculation and hydrogen and bleeding of impurities in hydrogen subsystem.

The figures depict embodiments of the disclosure for purposes of illustration only. One skilled in the art will readily recognize from the following description that alternative
10 embodiments of the structures and methods illustrated herein may be employed without departing from the principles of the disclosure described herein.

DETAILED DESCRIPTION

15 The foregoing has broadly outlined the features and technical advantages of the present disclosure in order that the detailed description of the disclosure that follows may be better understood. Additional features and advantages of the disclosure will be described hereinafter which form the subject of the claims of the disclosure. It should be appreciated by those skilled in the art that the conception and specific embodiment disclosed may be
20 readily utilized as a basis for modifying or designing other structures for carrying out the same purposes of the present disclosure. It should also be realized by those skilled in the art that such equivalent constructions do not depart from the spirit and scope of the disclosure as set forth in the appended claims. The novel features which are believed to be characteristic of the disclosure, both as to its organization and method of operation,
25 together with further objects and advantages will be better understood from the following description when considered in connection with the accompanying figures. It is to be expressly understood, however, that each of the figures is provided for the purpose of illustration and description only and is not intended as a definition of the limits of the present disclosure.

30 To overcome the drawbacks mentioned in the background, a system for recirculating hydrogen and bleeding impurities in the hydrogen subsystem is provided. The hydrogen

recirculation system includes a hydrogen recirculation blower in between fuel cell stack and hydrogen recirculation line. This recirculates the excess hydrogen present in the fuel cell stack. Further, the system includes a bleed valve for removing the condensed water and a solenoid valve for removing the other impurities from a fuel cell stack.

5
FIG. 1 is an exemplary block diagram of the system (1) for recirculating hydrogen and bleeding of impurities in hydrogen subsystem as one embodiment. The major components of the system (1) are hydrogen storage and delivery system (3), fuel cell stack (4), hydrogen recirculation blower (5), humidification system (7), hydrogen purging and
10 diffusing system (8) and nitrogen storage and delivery system (10).

The hydrogen storage and delivery sub system (3) consists of hydrogen cylinder to receive and store the hydrogen fuel, pressure relief valve to monitor the pressure of hydrogen fuel, electrically activated solenoid valve (9b) to supply the hydrogen to the fuel cell stack (4),
15 high pressure regulator and a dome loaded regulator to control the flow rate of hydrogen and plurality of mechanical interface blocks for mounting plurality of sensors. The sensors measure the temperature and pressure of the hydrogen. In one embodiment, the hydrogen storage and delivery sub system (3) is provided in the system (1) for storing and supplying hydrogen to a fuel cell stack (4) through a solenoid valve (9b) and a humidification system
20 (7) via hydrogen circulation line (6). The hydrogen supplied from the hydrogen storage and delivery sub system (3) to fuel cell stack (4) is regulated using dome loaded regulator based on power demand of the vehicle.

The system (1) provides hydrogen fuel to the fuel cell stack (4), at the required
25 temperature, pressure, humidity, and flow rate. The system (1) also removes anode waste gases and water. The system (1) delivers hydrogen safely, in the correct amount, at the right state i.e. pressure, temperature, humidity to the fuel cell stack (4). Also, the system (1) removes the excess hydrogen from the fuel cell stack (4).

30 The system (1) also includes, a hydrogen recirculation blower (5) provided in between anode compartment (4a) of the fuel cell stack (4) and the hydrogen circulation line (6) for

recirculating the hydrogen through the humidification system (7). The fuel cell stack (4) consists of an anode compartment (4a) and a cathode compartment (4b). The humidification system (7) humidifies the hydrogen before supplying to the fuel cell stack (4). A check valve (13) is placed in between the hydrogen recirculation blower (5) and the
5 hydrogen circulation line (6) to provide a unidirectional flow of recirculated hydrogen. The check valve (13) also increases a pressure of re-circulating hydrogen.

A nitrogen storage and delivery subsystem (10) is provided in the system (1) for storing and supplying nitrogen to a fuel cell stack (4) through a solenoid valve (9a) and a
10 humidification system (7) via hydrogen circulation line (6). The nitrogen storage and delivery sub system (10) comprises a nitrogen cylinder for storing a nitrogen gas, electrically actuated solenoid valve (9a) for supplying nitrogen to a fuel cell stack (4) to flush out inert gases.

15 The system (1) further includes hydrogen purging and diffusing system (8) provided in between the fuel cell stack (4) and the hydrogen recirculation blower (5) for removal of condensed water and accumulated impurities from the fuel cell stack (4). The hydrogen purging and diffusing system (8) comprises a bleed valve (11) for purging condensed water accumulated in anode compartment (4a) of the fuel cell stack (4) and water flooded from
20 cathode compartment to anode compartment. A solenoid valve (9c) is used to flush out accumulated impurities and entrapped air through the purge diffuser (12) with fan.

In one embodiment of the present disclosure, gravity is utilized in purging of condensed water and accumulated impurities from the fuel cell stack (4) through the hydrogen
25 purging and diffusing system (8).

In one embodiment of the present disclosure, it is important to measure pressure of hydrogen present in the fuel cell stack in order to maintain the healthy state of the fuel cell stack. In order to measure the pressure, plurality of pressure transducers are provided in the
30 anode and cathode compartments (4a and 4b) of the fuel cell stack (4).

FIG. 2 is an exemplary embodiment which illustrates interface of solenoid valves (9a-9c) and other components of system (1) with an electronic control unit (2) of the vehicle. The solenoid valves (9a-9c) are controlled by the electronic control unit (2) to regulate the flow of hydrogen and to flush out entrapped air and impurities from the fuel cell stack (4). The electronic control unit (2) will receive signal from the drivers input and plurality of sensors mounted in the fuel cell stack (4) to measure different parameters such as temperature, pressure and humidity and compares with the preset values stored in it. The said electronic control unit (2) opens the solenoid valves (9a-9c) depending on the drive mode of the vehicle to regulate supply of hydrogen to the fuel cell stack (4) and to remove the impurities from the fuel cell stack (4).

Further, the hydrogen recirculation blower (5) is interfaced with the electronic control unit (2), and said electronic control unit (2) sends signal to hydrogen recirculation blower (5) to run at a predetermined speed.

In addition, plurality of sensors and pressure transducers are interfaced with the electronic control unit (2) to measure temperature, pressure, and humidity of fuel cell stack (4) and compare with the preset values of temperature, pressure, and humidity stored in the electronic control unit (2) to maintain the aforesaid parameter within the preset limit.

FIG. 3 is an exemplary embodiment illustrates a flow chart to monitor different parameters of the system (1) for recirculation and hydrogen and bleeding of impurities in hydrogen subsystem. The electronic control unit (2) checks the mode of operation of the vehicle through a driver input. The operation mode is atleast one of startup mode, run mode, emergency mode and shutdown mode. If vehicle is operating in startup mode then the electronic control unit (2) checks startup time, if the start up time measured by the electronic control unit (2) is less than preset value of time then the electronic control unit opens the solenoid valves (9a and 9c) for flushing out the entrapped air by passing a nitrogen stored in nitrogen storage and delivery system (10). If the time measured by electronic control unit (2) is greater than preset limit then electronic control unit (2)

measures the voltage of the fuel cell stack (4). If the measured voltage measured is less than the preset limit then the electronic control unit (2) opens the solenoid valves (9b and 9c) to supply hydrogen to the fuel cell stack (4) to avoid starvation of hydrogen in the fuel cell stack (4). In the emergency mode the electronic control unit (2) activates the solenoid valves (9a and 9c) to flush out hydrogen from the fuel cell stack (4). If the vehicle is in shutdown mode then the electronic control unit (2) measures a temperature of the fuel cell stack (4), if the temperature measured by the electronic control unit (2) is less than preset limit of temperature then the electronic control unit (2) activates the solenoid valves (9a and 9c) to flush out the hydrogen from the fuel cell stack (4). By doing this there will be no hydrogen trapped in the system (1) while shutting off the vehicle.

In one embodiment of the present disclosure, the preset values of temperature, voltage and startup time are stored in the electronic control unit (2). The preset values of startup time, voltage, and temperature will vary from vehicle to vehicle and values are preferably 60 seconds, 260 volts and 40m degree Celsius respectively.

In one embodiment of the present disclosure, if the voltage measured by the electronic control unit (2) is less than preset value then excess of hydrogen is supplied to the fuel cell stack (4) to prevent starvation of hydrogen in the fuel cell stack (4).

Advantages:

The present disclosure provides a system for recirculation of hydrogen from a fuel cell stack which generates a gravity required for purging impurities from the fuel cell stack.

The present disclosure provides a system which purges the condensed water and other accumulated impurities from the fuel cell stack.

The present disclosure provides a system which purge out hydrogen from the fuel cell stack in emergency and shutdown modes.

The present disclosure provides a system which automatically monitors the recirculation of hydrogen and draining of impurities by opening plurality of solenoid valves through an electronic control unit of the vehicle.

- 5 The present disclosure provides a system which supplies the hydrogen to the fuel cell stack at correct state i.e. temperature, pressure, and humidity.

Equivalents

- 10 With respect to the use of substantially any plural and/or singular terms herein, those having skill in the art can translate from the plural to the singular and/or from the singular to the plural as is appropriate to the context and/or application. The various singular/plural permutations may be expressly set forth herein for sake of clarity.

- 15 It will be understood by those within the art that, in general, terms used herein, and especially in the appended claims (e.g., bodies of the appended claims) are generally intended as "open" terms (e.g., the term "including" should be interpreted as "including but not limited to," the term "having" should be interpreted as "having at least," the term "includes" should be interpreted as "includes but is not limited to," etc.). It will be further
20 understood by those within the art that if a specific number of an introduced claim recitation is intended, such an intent will be explicitly recited in the claim, and in the absence of such recitation no such intent is present. For example, as an aid to understanding, the following appended claims may contain usage of the introductory phrases "at least one" and "one or more" to introduce claim recitations. However, the use
25 of such phrases should not be construed to imply that the introduction of a claim recitation by the indefinite articles "a" or "an" limits any particular claim containing such introduced claim recitation to inventions containing only one such recitation, even when the same claim includes the introductory phrases "one or more" or "at least one" and indefinite articles such as "a" or "an" (e.g., "a" and/or "an" should typically be interpreted to mean "at
30 least one" or "one or more"); the same holds true for the use of definite articles used to introduce claim recitations. In addition, even if a specific number of an introduced claim

recitation *is* explicitly recited, those skilled in the art will recognize that such recitation should typically be interpreted to mean *at least* the recited number (e.g., the bare recitation of "two recitations," without other modifiers, typically means *at least* two recitations, or *two or more* recitations). Furthermore, in those instances where a convention analogous to

5 "at least one of A, B, and C, etc." is used, in general such a construction is intended in the sense one having skill in the art would understand the convention (e.g., "a system having at least one of A, B, and C" would include but not be limited to systems that have A alone, B alone, C alone, A and B together, A and C together, B and C together, and/or A, B, and C together, etc.). In those instances where a convention analogous to "at least one of A, B, or

10 C, etc." is used, in general such a construction is intended in the sense one having skill in the art would understand the convention (e.g., "a system having at least one of A, B, or C" would include but not be limited to systems that have A alone, B alone, C alone, A and B together, A and C together, B and C together, and/or A, B, and C together, etc.). It will be further understood by those within the art that virtually any disjunctive word and/or phrase

15 presenting two or more alternative terms, whether in the description, claims, or drawings, should be understood to contemplate the possibilities of including one of the terms, either of the terms, or both terms. For example, the phrase "A or B" will be understood to include the possibilities of "A" or "B" or "A and B."

20 While various aspects and embodiments have been disclosed herein, other aspects and embodiments will be apparent to those skilled in the art. The various aspects and embodiments disclosed herein are for purposes of illustration and are not intended to be limiting, with the true scope and spirit being indicated by the following claims.

25 Referral Numerals:

Reference number	Description
1	Hydrogen recirculation and bleeding system
2	Electronic control unit
3	Hydrogen storage and

	delivery subsystem
4	Fuel cell stack
4a	Anode compartment of fuel cell stack
4b	Cathode compartment of fuel cell stack
5	Hydrogen recirculation blower
6	Hydrogen circulation line
7	Humidification system
8	Hydrogen purging and diffusing system
9a-9c	Solenoid valve
10	Nitrogen storage and delivery system
11	Bleed valve
12	Purge diffuser
13	Check valve

We claim:

1. A system (1) for recirculating hydrogen and bleeding of impurities in hydrogen subsystem of polymer electrolyte fuel cell of a vehicle, said system comprises;
5 an electronic control unit (2) of the vehicle,
 a hydrogen storage and delivery subsystem (3) interfaced with the electronic control unit (2) to store and supply the hydrogen to a fuel cell stack (4) through a solenoid valve (9b) and a humidification system (7);
 a hydrogen recirculation blower (5) connected to the fuel cell stack (4) and
10 a hydrogen circulation line (6);
 a nitrogen storage and delivery sub system (10) interfaced with the electronic control unit (2) to store and supply the nitrogen to a fuel cell stack (4) through a solenoid valve (9a) and the humidification system (7);
 a hydrogen purging and diffusing system (8) provided in between the fuel
15 cell stack (4) and hydrogen recirculation blower (5), wherein said hydrogen purging and diffusing system (8) facilities removal of condensed water and other impurities from the fuel cell stack (4).
2. The system as claimed in claim 1, wherein the hydrogen purging and diffusing
20 system (8) comprises a bleed valve (11) for removing the condensed water and solenoid valve (9c) for removing the accumulated impurities in the fuel cell stack (4) through a purge diffuser (12) with fan.
3. The system as claimed in claim 1, wherein gravity is utilized in draining the
25 condensed water and impurities from the fuel cell stack (4).
4. The system as claimed claim 1, wherein a check valve (13) is provided in between
the hydrogen recirculation blower (5) and the hydrogen circulation line (6) to
increase the pressure of recirculating hydrogen and to allow the unidirectional flow
30 of the recirculating hydrogen.

5. The system as claimed in claim 1, wherein plurality of pressure transducers are provided in the fuel cell stack (4) for measuring a pressure of hydrogen in the stack (4).

5

6. The system as claimed in claim 1, wherein plurality of thermal and humidity sensors are provided at predetermined locations, and said sensors are interfaced with the electronic control unit (2) to provide level of temperature and humidity of the fuel cell stack (4).

10

7. A method for recirculating hydrogen and bleeding of impurities in hydrogen subsystem of polymer electrolyte fuel cell of a vehicle, said method comprising acts of;

15

checking a mode of operation of a vehicle by means of driver input; wherein said mode comprises startup mode, run mode, emergency mode and shut down mode;

20

opening a solenoid valves (9a and 9c) to flush out entrapped air from a fuel cell stack (4) when start up time measured by an electronic control unit (2) during the startup mode is less than preset time limit;

opening a solenoid valves (9b and 9c) when the start up time is more than the preset limit and voltage of fuel stack (4) measured by the electronic control unit (2) is less than preset voltage limit to supply hydrogen to a fuel cell stack (4) to prevent starvation of hydrogen during the run mode;

25

opening the solenoid valves (9a and 9c) flush out hydrogen from a fuel cell stack (4) when a temperature of the stack (4) measured by the electronic control unit (2) during the shutdown mode is less than preset temperature level;

30

wherein an excess hydrogen is recirculated from a fuel cell stack (4) through a humidification system (7) using a hydrogen recirculation blower (5) for improving an efficacy of hydrogen.

8. The method as claimed in claim 7, wherein opening of solenoid valve (9a and 9c) to flush out hydrogen from the fuel cell stack (4) during the emergency mode.
- 5 9. The method as claimed in claim 7, wherein condensed water in the fuel cell stack (4) is drained by bleed valve (11).
10. The method as claimed in claim 7, wherein the preset limits of startup time, fuel cell stack (4) voltage and fuel cell stack temperature are stored in the electronic control unit (2).
- 10 11. A vehicle comprising a system (1) for recirculating hydrogen and bleeding of impurities in hydrogen subsystem of polymer electrolyte fuel cell as claimed in claim 1.
- 15 12. A system (1) for recirculating hydrogen and bleeding of impurities in hydrogen subsystem of polymer electrolyte fuel cell of a vehicle and a method for recirculating hydrogen and bleeding of impurities in hydrogen subsystem of polymer electrolyte fuel cell of a vehicle are substantially as herein above described and as illustrated in accompanying drawings.

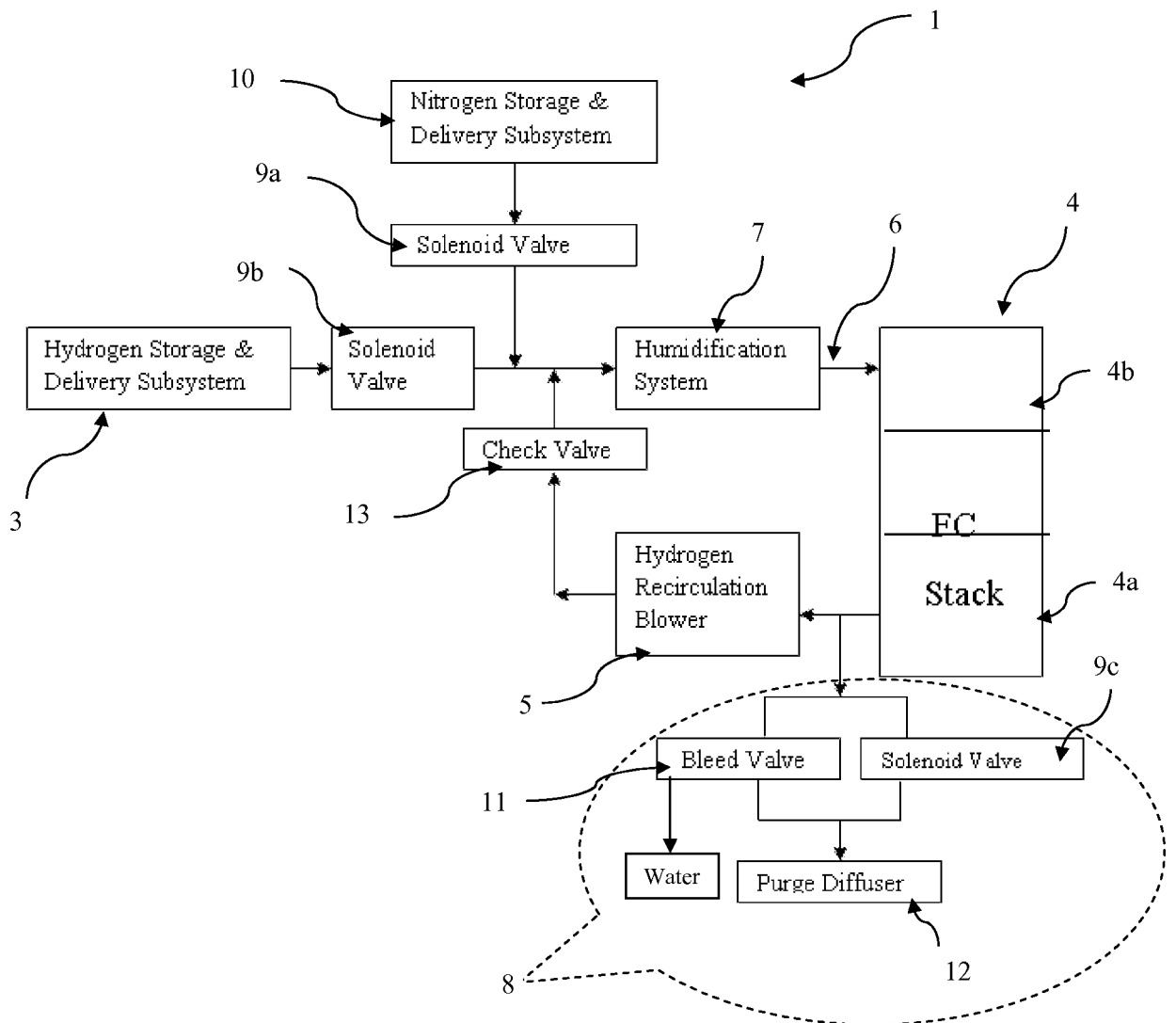

FIG. 1

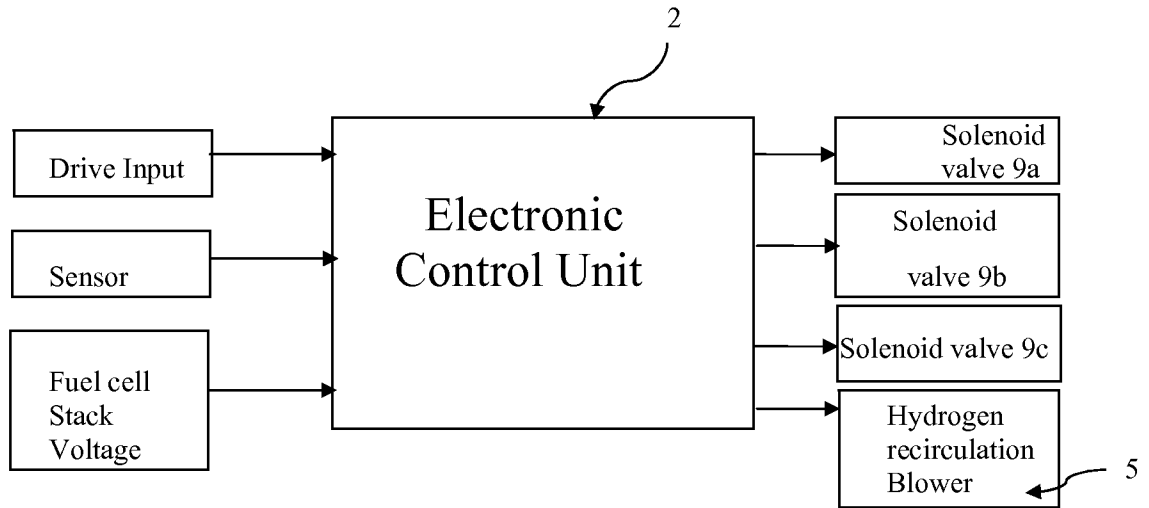

FIG. 2

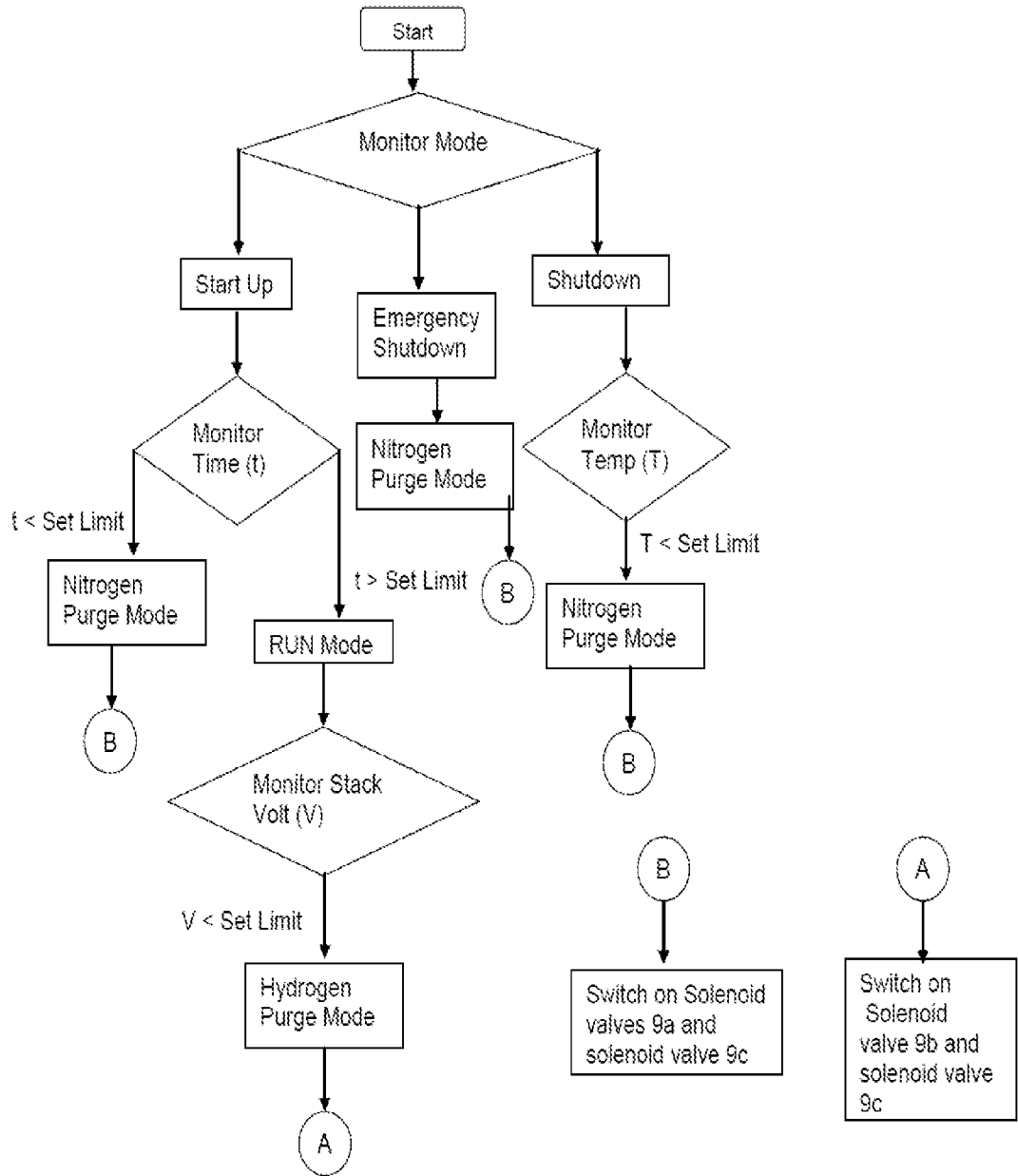

FIG. 3

INTERNATIONAL SEARCH REPORT

International application No PCT/IB2012/051174
--

A. CLASSIFICATION OF SUBJECT MATTER INV. H01M8/04 ADD.		
According to International Patent Classification (IPC) or to both national classification and IPC		
B. FIELDS SEARCHED		
Minimum documentation searched (classification system followed by classification symbols) H01M		
Documentation searched other than minimum documentation to the extent that such documents are included in the fields searched		
Electronic data base consulted during the international search (name of data base and, where practicable, search terms used) EPO-Internal, WPI Data		
C. DOCUMENTS CONSIDERED TO BE RELEVANT		
Category*	Citation of document, with indication, where appropriate, of the relevant passages	Relevant to claim No.
X	US 2007/065711 A1 (GOPAL RAVI B [US]) 22 March 2007 (2007-03-22)	1,3,5-12
Y	paragraph [0034] - paragraph [0074]; figures 1-4	2,4
Y	----- US 2006/073363 A1 (TANIGUCHI IKUHIRO [JP] ET AL) 6 April 2006 (2006-04-06) the whole document	2
Y	----- WO 94/10716 A1 (BALLARD POWER SYSTEMS [CA]; WILKINSON DAVID P [CA]; VOSS HENRY H [CA];) 11 May 1994 (1994-05-11) the whole document	4
A	----- US 2006/134478 A1 (FUSE TORU [JP]) 22 June 2006 (2006-06-22) the whole document	1-12
----- -/--		
<input checked="" type="checkbox"/> Further documents are listed in the continuation of Box C. <input checked="" type="checkbox"/> See patent family annex.		
* Special categories of cited documents :		
"A" document defining the general state of the art which is not considered to be of particular relevance	"T" later document published after the international filing date or priority date and not in conflict with the application but cited to understand the principle or theory underlying the invention	
"E" earlier application or patent but published on or after the international filing date	"X" document of particular relevance; the claimed invention cannot be considered novel or cannot be considered to involve an inventive step when the document is taken alone	
"L" document which may throw doubts on priority claim(s) or which is cited to establish the publication date of another citation or other special reason (as specified)	"Y" document of particular relevance; the claimed invention cannot be considered to involve an inventive step when the document is combined with one or more other such documents, such combination being obvious to a person skilled in the art	
"O" document referring to an oral disclosure, use, exhibition or other means	"&" document member of the same patent family	
"P" document published prior to the international filing date but later than the priority date claimed		
Date of the actual completion of the international search	Date of mailing of the international search report	
11 July 2012	20/07/2012	
Name and mailing address of the ISA/ European Patent Office, P.B. 5818 Patentlaan 2 NL - 2280 HV Rijswijk Tel. (+31-70) 340-2040, Fax: (+31-70) 340-3016	Authorized officer Brune, Markus	

INTERNATIONAL SEARCH REPORT

International application No
PCT/IB2012/051174

C(Continuation). DOCUMENTS CONSIDERED TO BE RELEVANT

Category*	Citation of document, with indication, where appropriate, of the relevant passages	Relevant to claim No.
A	WO 2005/031901 A2 (NISSAN MOTOR [JP]; FUKUDA TAKASHI [JP]) 7 April 2005 (2005-04-07) the whole document -----	1-12

INTERNATIONAL SEARCH REPORT

Information on patent family members

International application No PCT/IB2012/051174

Patent document cited in search report	Publication date	Patent family member(s)	Publication date
US 2007065711 A1	22-03-2007	CA 2623460 A1 EP 1927150 A2 US 2007065711 A1 WO 2007033478 A2	29-03-2007 04-06-2008 22-03-2007 29-03-2007

US 2006073363 A1	06-04-2006	JP 2006099993 A US 2006073363 A1	13-04-2006 06-04-2006

WO 9410716 A1	11-05-1994	AU 675998 B2 AU 5541394 A CA 2146325 A1 DE 69328874 D1 DE 69328874 T2 EP 0671057 A1 JP H08507405 A US 5366818 A WO 9410716 A1	27-02-1997 24-05-1994 11-05-1994 20-07-2000 11-01-2001 13-09-1995 06-08-1996 22-11-1994 11-05-1994

US 2006134478 A1	22-06-2006	CN 1860634 A EP 1535361 A2 JP 2004349068 A KR 20050075383 A US 2006134478 A1 WO 2004105165 A2	08-11-2006 01-06-2005 09-12-2004 20-07-2005 22-06-2006 02-12-2004

WO 2005031901 A2	07-04-2005	EP 1678773 A2 JP 4882198 B2 JP 2005100827 A US 2006210853 A1 US 2008280176 A1 WO 2005031901 A2	12-07-2006 22-02-2012 14-04-2005 21-09-2006 13-11-2008 07-04-2005
