

F. A. CANFIELD.  
 Cartridge Capping and Uncapping Implement.  
 No. 216,554.      Patented June 17, 1879.

*Figure 1.*

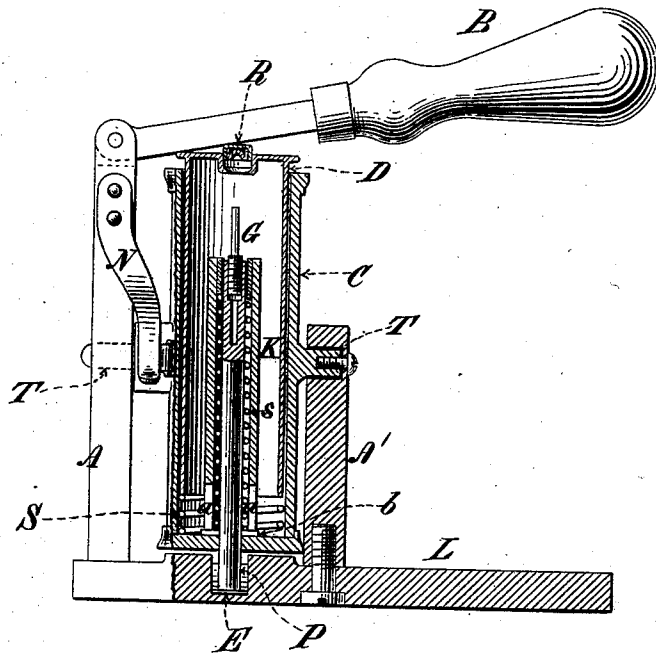

*Figure 2.*

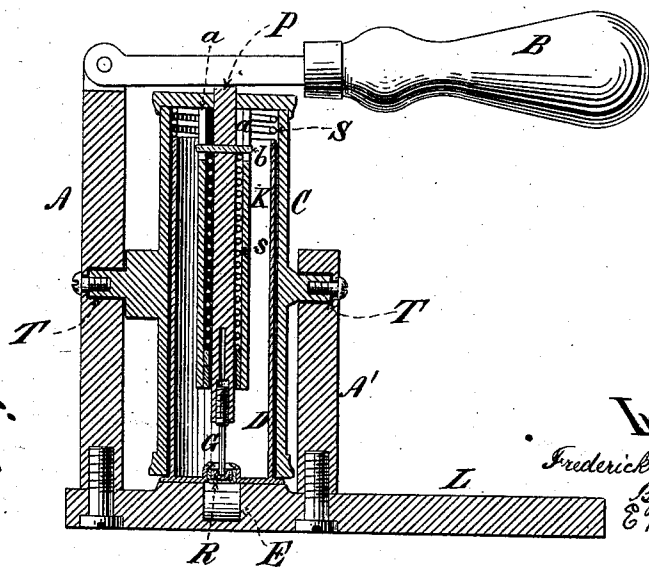

Witnesses:  
 Geo. H. Miatt  
 Albrecht

Inventor:  
 Frederick A. Canfield  
 By his Attorney  
 C. W. Dickerson, Jr.

# UNITED STATES PATENT OFFICE.

FREDERICK A. CANFIELD, OF DOVER, NEW JERSEY.

## IMPROVEMENT IN CARTRIDGE CAPPING AND UNCAPPING IMPLEMENTS.

Specification forming part of Letters Patent No. 216,554, dated June 17, 1879; application filed April 19, 1879.

### *To all whom it may concern:*

Be it known that I, FREDERICK A. CANFIELD, of Dover, in the State of New Jersey, have invented a new and useful Apparatus for Capping and Uncapping Shot-Gun and other Shells or Cases for Ammunition, of which the following is a full, true, and exact description, reference being had to the accompanying drawings.

The object of my improvement is to produce an apparatus by means of which a cap can be readily applied to the ordinary shell, either metallic or paper, which is used in shot-guns, or other similar cases for ammunition, and by means of which said cap can be readily removed from the shell after firing; and my apparatus accomplishes both these ends without removing the shell from its position in the apparatus by merely reversing the position of the shell-supporting cylinder or case, which has, I believe, never before been done.

My apparatus consists, generally, of a base or support for the apparatus, carrying a reversible shell case or tube mounted upon trunnions, which tube contains apparatus for removing the cap from the shell. By means of it either end of the shell can be brought beneath a lever, also carried on the frame of the apparatus, which lever is used both to press the cap in position in the head of the shell, and also to act against the uncapping apparatus when the shell case or tube is reversed.

My apparatus will be readily understood from the accompanying drawings, in which both the figures represent sections—

Figure 1 being the apparatus in the position used for capping a shell, and Fig. 2 in the position in which it is in the operation of uncapping.

L represents the base, carrying two small uprights, A A', the longer of which supports the operating-lever B. The two supports A A' serve to hold the trunnions T of the shell case or tube C, which can be revolved or reversed, so as to bring either end beneath the lever B. The trunnion T, set in the longer support, A, is provided with two flat surfaces, and a spring, N, is attached to such support in such a way as to act against these flat surfaces, so as to hold the tube C vertical whichever end may be uppermost.

Many other devices may be used for this purpose, the object being to insure the central position of the tube C beneath the lever without necessitating adjustment by the operator.

The tube C is preferably made of different sizes, to accommodate the shell which is to be operated in the apparatus; or the tube could be made large enough to admit and accommodate the largest shell, and a bushing or filling could be inserted for smaller shells. The bottom of this tube C is permanently closed, and contains a spring, S, arranged to act against the open end of the shell when in position, and against the tube to raise the head of the shell free from the open end of the tube C, for the purpose of enabling the ready removal of the shell D from the tube by the fingers of the operator. The sides of the tube C might be cut away to accomplish the same purpose.

Fastened permanently into the center of the solid head of the tube C is the smaller tube, K, which serves to support and guide the uncapping apparatus, as will be presently described. Within this tube, and supported by its free end, is the uncapping-stem P, which is arranged centrally in the apparatus, so as to act against the cap, which is also arranged centrally in the head of the shell. This stem is supported by passing through the solid head of the tube C, presenting a projecting portion, to be acted against by the lever B, as shown in Fig. 2. Its other end is supported by the free end of the tube. In the bottom of this tube K are placed two vertical slots, a. Passing through these slots and through the central pin, P, is the pin b, which serves to limit the motion of the pin P vertically and to prevent its revolution. Surrounding the central pin, P, and inclosed by the tube K, is the spiral spring s, one end of which bears against the pin b, just described, and the other against a collar or stem or some other similar arrangement in the free end of the tube K, the object of this spring being to act against the stem P and cause its end to protrude through the closed end of the shell-tube C, and at the same time to withdraw the point G from the hole in the head of the shell, as shown in Fig. 1. In the end of the stem P which is situated within the case C is

screwed the uncapping-pin G, which is caused to act against the cap in the process of uncapping.

Shells are, generally speaking, of two kinds. In one of them a central aperture extends through the head of the shell, allowing the insertion of a pin through the body of the shell, so as to act against the cap when in position, and thus uncap the shell. In the other kind, usually known as the "Sturtevant," the cap rests against a free anvil which has a certain amount of motion in the head of the shell, and any broad surface acting against the inner surface of this anvil will force it outward and cause the cap to leave its position in the head of the shell. My apparatus is arranged to operate upon either kind of shell. The pin G, screwed into the head of the stem P, is reversible, one end being flat, for the purpose of acting against the uncapping device of the "Sturtevant," the other being provided with a pin in the form shown in the figures, which is constructed to pass through the opening in the head of the shell, and thereby force the cap from its position. A recess is provided in the body of the pin P, allowing of the reversal of this uncapping device, as will be clearly understood from the drawings.

A channel, E, is cut in the base L at right angles to the lever B, in the direction of the motion of the tube C, for the reception of the projecting end of the stem P, and also to allow a space into which the cap may be forced in the process of uncapping, the apparatus being so contrived that when it is reversed in the position shown in Fig. 2 the head of the shell rests against the base of the apparatus, and is supported by it in the process of uncapping.

The operation of the apparatus can now be understood. The shell having been fired so as to explode the cap, this shell is placed in position in the center of the tube C, as shown in Fig. 1. This case is then reversed into the position shown in Fig. 2, thereby bringing the head of the shell against the base of the apparatus and the cap itself over the channel E. The apparatus then being in the position shown at Fig. 2, by pressing upon the lever B, the pin G is forced against the cap R, which is thereby removed from the head of the shell and drops into the channel E. The lever B is then released and the tube C is reversed into the position shown in Fig. 1. The projecting end of the pin P sweeping through the channel E throws the old cap out of such channel, and the apparatus is in the position shown in Fig. 1, ready for a new cap. This cap being placed

in position as there shown, the lever B is depressed, thereby forcing the cap into position. By releasing once more the pressure of the lever B the spring S raises the shell, so that it can be readily removed by the fingers of the operator.

It will be readily seen that by means of this apparatus the operations of uncapping and capping can be quickly and readily performed without necessitating any handling of the shell, which is so placed in the apparatus that without removal therefrom it can be brought into position for removing the old cap and placing a new cap therein.

What I claim as my invention, and desire to secure by Letters Patent, is—

1. The combination of a pivoted reversible shell-tube, the capping-lever, and the uncapping apparatus, said apparatus being adapted to be operated by the lever when the shell-case is reversed, substantially as described.

2. The combination of a reversible pivoted cartridge-tube, carrying an uncapping apparatus, and a lever adapted to force the cap in position or to act against the uncapping apparatus, substantially as described.

3. The combination of a pivoted reversible cartridge-tube and a base-plate provided with a slot extending in a line parallel to the movement of the cartridge-case, for the purpose of allowing the ejection of the cap, and also to allow of the passage of the uncapping-rod when the cartridge-shell is reversed, substantially as described.

4. The pivoted reversible cartridge-tube C, having the uncapping-rod P, supported centrally therein, extending through the head of the case, thereby allowing of its engagement with the hand-lever B, substantially as described.

5. The pivoted reversible cartridge-tube C, having the uncapping-rod P, supported centrally therein, extending through the head of the case, thereby allowing of its engagement with a hand-lever, B, and the base provided with a slot, E, thereby enabling the use of the ejector-pin to throw the cap clear of the slot, substantially as described.

6. The pivoted reversible shell-tube, adapted to receive and support the shell and to bring it in a position to be uncapped and recapped without removal from the supporting-case, substantially as described.

FREDERICK A. CANFIELD.

Witnesses:

S. F. SULLIVAN,  
WM. J. SAWYER.