



INTERNATIONAL APPLICATION PUBLISHED UNDER THE PATENT COOPERATION TREATY (PCT)

<p>(51) International Patent Classification ⁶ : B65D 51/28</p>	<p>A1</p>	<p>(11) International Publication Number: WO 98/38104</p> <p>(43) International Publication Date: 3 September 1998 (03.09.98)</p>
<p>(21) International Application Number: PCT/IT97/00222</p> <p>(22) International Filing Date: 10 September 1997 (10.09.97)</p> <p>(30) Priority Data: MO97A000029 28 February 1997 (28.02.97) IT</p> <p>(71) Applicant (for all designated States except US): BORMIOLI ROCCO & FIGLIO S.P.A. [IT/IT]; Via San Leonardo, 41, I-43100 Parma (IT).</p> <p>(72) Inventor; and (75) Inventor/Applicant (for US only): MORINI, Emilio [IT/IT]; Via A. Moro, 35, I-43052 Colorno (IT).</p> <p>(74) Agent: NERI, Luciano; Bugnion S.p.A., Via Emilia Est, 25, I-41100 Modena (IT).</p>		<p>(81) Designated States: AL, AM, AT, AU, AZ, BA, BB, BG, BR, BY, CA, CH, CN, CU, CZ, DE, DK, EE, ES, FI, GB, GE, GH, HU, IL, IS, JP, KE, KG, KP, KR, KZ, LC, LK, LR, LS, LT, LU, LV, MD, MG, MK, MN, MW, MX, NO, NZ, PL, PT, RO, RU, SD, SE, SG, SI, SK, TJ, TM, TR, TT, UA, UG, US, UZ, VN, YU, ARIPO patent (GH, KE, LS, MW, SD, SZ, UG, ZW), Eurasian patent (AM, AZ, BY, KG, KZ, MD, RU, TJ, TM), European patent (AT, BE, CH, DE, DK, ES, FI, FR, GB, GR, IE, IT, LU, MC, NL, PT, SE), OAPI patent (BF, BJ, CF, CG, CI, CM, GA, GN, ML, MR, NE, SN, TD, TG).</p> <p>Published <i>With international search report.</i></p>

(54) **Title:** A PACKAGE FOR KEEPING PRODUCTS SEPARATE BEFORE USE

(57) **Abstract**

A package for keeping products separate until use comprises a container (1) provided with an upper mouth (2) inside which a capsule (3) is inserted; the capsule having a bottom (4) which is destined at the moment of use of the package to be broken by a cutting element (11). A cap (13) covers the capsule (3) and the cutting element (11), and is screwed on a sleeve (6) solidly constrained to the capsule (3). When a security strip (16) is removed the cap (13) can be screwed, placing a pressure on the cutting element (11) which causes the capsule (3) to be ruptured and a product contained therein to mix with a product contained in the container.

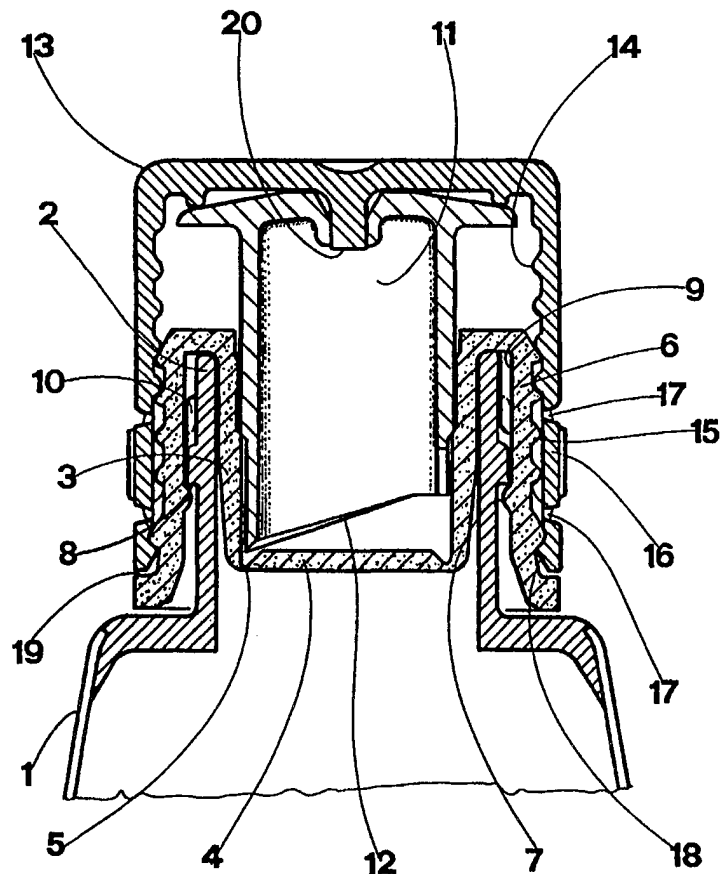

FOR THE PURPOSES OF INFORMATION ONLY

Codes used to identify States party to the PCT on the front pages of pamphlets publishing international applications under the PCT.

AL	Albania	ES	Spain	LS	Lesotho	SI	Slovenia
AM	Armenia	FI	Finland	LT	Lithuania	SK	Slovakia
AT	Austria	FR	France	LU	Luxembourg	SN	Senegal
AU	Australia	GA	Gabon	LV	Latvia	SZ	Swaziland
AZ	Azerbaijan	GB	United Kingdom	MC	Monaco	TD	Chad
BA	Bosnia and Herzegovina	GE	Georgia	MD	Republic of Moldova	TG	Togo
BB	Barbados	GH	Ghana	MG	Madagascar	TJ	Tajikistan
BE	Belgium	GN	Guinea	MK	The former Yugoslav Republic of Macedonia	TM	Turkmenistan
BF	Burkina Faso	GR	Greece	ML	Mali	TR	Turkey
BG	Bulgaria	HU	Hungary	MN	Mongolia	TT	Trinidad and Tobago
BJ	Benin	IE	Ireland	MR	Mauritania	UA	Ukraine
BR	Brazil	IL	Israel	MW	Malawi	UG	Uganda
BY	Belarus	IS	Iceland	MX	Mexico	US	United States of America
CA	Canada	IT	Italy	NE	Niger	UZ	Uzbekistan
CF	Central African Republic	JP	Japan	NL	Netherlands	VN	Viet Nam
CG	Congo	KE	Kenya	NO	Norway	YU	Yugoslavia
CH	Switzerland	KG	Kyrgyzstan	NZ	New Zealand	ZW	Zimbabwe
CI	Côte d'Ivoire	KP	Democratic People's Republic of Korea	PL	Poland		
CM	Cameroon	KR	Republic of Korea	PT	Portugal		
CN	China	KZ	Kazakstan	RO	Romania		
CU	Cuba	LC	Saint Lucia	RU	Russian Federation		
CZ	Czech Republic	LI	Liechtenstein	SD	Sudan		
DE	Germany	LK	Sri Lanka	SE	Sweden		
DK	Denmark	LR	Liberia	SG	Singapore		
EE	Estonia						

-1-

Description

A Package for Keeping Products separate before Use.

Technical Field

The invention relates to a package for keeping products separate before use.

For some time now the market has offered medicines packaged in two separate phases: the first of the medicines is a powder, while the second is a liquid, and they have to be kept separate until the moment of use. Packages for such medicinal mixtures comprise a container for the liquid and a capsule for the
5 powders, which are set in communication just before use so that they can mix.

Background Art

One of the packages of the above-described type on the market is provided with a cutting element which by means of a pressure applied thereto inserts into the
10 liquid container, which is closed off by a thin membrane; the cutting element ruptures the membrane so that the powders can penetrate into the container. A package of this type is described, for example, in Italian patent for industrial invention no. 1,066,140, wherein the cutting element is in fact a hollow cylinder with an oblique-section end, made in a single piece with walls which close the
15 mouth of the container. This package exhibits a lateral strip, removable by tugging along two easy-break parallel lines exhibiting a tab-pull; the user can grip this strip, the removal of which enables the cutting element to make an axial movement. When it is desired to mix the powder with the liquid solvent, the strip must first be removed and then the cutting element pressed using a finger so that
20 the bottom of the little powder container is ruptured and the powders can mix with the liquid.

-2-

Another prior-art package comprises a protection hood, which covers the cutting element and the powder container and which is destined to be removed by tearing at the moment of use in order that the cutting element can be pressed. A package of this type is shown, for example, in Italian application for industrial invention
5 no. RM91A000831.

The prior-art packages contain some drawbacks.

Firstly, in order to avoid a deterioration of the powder quality, the coupling between the external surface of the cutting element and the internal surface of the powder container must be sealed to guarantee a hermetic seal on the container.
10 However, the correct realisation of such coupling is especially difficult to achieve, inasmuch as if the coupling is too tight, a strong pressure will have to be applied to the cutting element, which is not only hard to do but can cause the user to perform the operation wrongly, i.e. not by pressing with a finger on the cap-capsule but by tipping up the package and pressing the cap against a solid
15 surface. This can mean that the mixture is not obtained in the correct manner, as the powder does not fall directly into the liquid but vice-versa, leading to the formation of lumps which are difficult to remove from the cap-capsule. Thus a wrong mixture of the medicine is obtained.

In series production of plastic objects at industrial levels it is quite difficult to
20 obtain size tolerances which would guarantee a constantly correct and desired connection between the cutting element and the cap-capsule.

A further problem in prior-art packages is as follows: at the moment of use, after the mixing phase of the substances (powders and liquid), the container is opened to allow the mixture to be removed. The container, which stays in the mouth of
25 the container even after the cap has been extracted, represents an obstacle which can disturb the pouring-out of the mixture, making it irregular and discontinuous. An aim of the present invention is to eliminate the above-described drawbacks

-3-

by providing a package, simple in construction and economical, which guarantees the seal and security of the package before use and which enables the package to be opened simply and practically.

The invention allows the powder container to be set in communication with the liquid container by means of a simple screwing operation of the former on to the latter, requiring only a small effort on the part of the consumer, who, among other things, will not upturn the package in order to break the bottom of the cap-capsule and so will avoid the problem of lump-formation and the like.

Also, at the moment of use and after the mixture has been united, the powder-container can be removed from the mouth of the container together with the cap and the cutting element, so leaving the container mouth free of obstruction.

An advantage of the invention is that it provides a package which is easily realisable and which is safe from liquid-permeation and which guarantees that the cap cannot be removed from the container until after the mixture of the two products has been obtained.

Disclosure of Invention

The above aims and others besides are all attained with the package of the invention, as it is characterised in the claims that follow.

Further characteristics and advantages of the present invention will better emerge from the detailed description that follows of a preferred but non-exclusive embodiment of the invention, illustrated purely by way of non-limiting example in the accompanying figures of the drawings, in which:

figure 1 shows a section according to a vertical plane of a first embodiment of the package, with the products separated;

figure 2 is the section of figure 1, with the package in a different configuration, in which the products are in communication;

-4-

figure 3 is a vertical elevation of a second embodiment of the package;

figure 4 is a section made according to line IV-IV of figure 3;

figure 5 is the section of figure 4 with the package in a different configuration in which the products, separated previously, are now in communication;

5 figure 6 is the package of figure 5 with the cap detached from the container.

The following description will make reference to the first embodiment of the invention (figures 1 and 2). The package of the invention comprises a container 1, provided with an upper mouth 2, internally of which a superiorly-open capsule 3 is inserted slightly tight. The side surfaces of both the capsule 3 and the mouth 2, set in contact at the moment of packaging, guarantee a perfect seal against any possible leaking of the liquid from the container 1. The capsule 3 comprises a bottom 4 which is easily breakable along a peripheral easy-break line 5. The bottom 4 of the capsule 3 separates the liquid present in the container 1 from the capsule 3 itself. When the bottom 4 is ruptured the capsule 3 is set in communication with the inside of the container 1.

The capsule is made in a single piece with a sleeve body 6, coaxial to the capsule 3 and the neck of the container 1 and arranged externally of the neck itself. The sleeve 6 exhibits an annular projection 7 coupled below in an annular recess 8 on the external surface of the container 1 neck, so that axial raising movements of the sleeve 6 are eliminated or limited. Also provided are means for preventing rotation of the sleeve 6 with respect to the mouth 2 of the container, which means comprise an annular crown of ribs 9 arranged on the internal surface of the sleeve 6, which engage in relative channels obtained in a similar annular crown of ribs 10 situated on the external surface of the mouth 2 of the container 1.

25 A cutting element 11, having the shape of a hollow cylindrical body, is predisposed internally of the capsule 3. The external surface of the cutting element 11 is coupled by slight sealing friction with the internal surface of the

-5-

capsule 3. The lower end 12 of the cutting element 11 is sharpened inasmuch as it exhibits an oblique section, which pointed lower end 12 is destined in use to break through the capsule 3 by means of an applied pressure. Figure 2 shows the package with the capsule 3 broken through by the cutting element 11 and set in communication with the inside of the container 1.

The package further comprises a cap 13 arranged on the container 1 in such a way as to cover the capsule 3 and the cutting element 11. The cap 13 is separated from the cutting element 11 and does not form a single body therewith. The upper wall of the cutting element 11 is in contact with the internal surface of the upper wall of the cap 13. The cap 13 internally exhibits a thread 14 coupled with a thread 15 situated externally on the sleeve 6. This screw-coupling enables the cap 13 to move axially downwards and upwards with respect to the mouth 2 of the container. The cap 13 is provided with a removable element, constituted by an annular security strip 16 which can be torn along two easy-break perimeter lines 17. With the strip in place the cap 13 cannot move axially downwards or upwards. The removal of the strip 16 enables the cap 13 to be screwed on the sleeve 6. Figure 1 shows the package with the strip 16 unremoved. In this configuration, which is how the package is sold, the cap 13 is solidly constrained to the rest of the package. In figure 2 the strip 16 has been removed and the cap 13 has been screwed. Both easy-break perimeter lines 17 are situated at a lower level with respect to the upper margin of the mouth of the container 1. The lower end of the cap 13 exhibits an annular relief 18, projecting internalwise, coupled below in a corresponding cavity on the sleeve 6, such as to prevent or limit axial raising movements of the cap 13. The sleeve 6 further exhibits a striking surface 19 for preventing or limiting axial upwards or downwards movements of the cap 13.

The cap 13 internally and centrally exhibits a protuberance 20 which inserts in

-6-

an opening afforded in the upper wall of the cutting element 11. This opening, once opened after the cap 13 has been unscrewed, serves to allow the liquid to exit drop by drop from the container 1. The opening can be closed by rescrewing the cap 13.

- 5 The various elements composing the package are made of plastic for medicinal use, of known type and in common use.

Figure 1 shows the package before use, with the liquid (the solvent) in the container separated from the powder (the solute) in the capsule 3. At the moment of use, the security strip 16 is torn away, freeing the cap 13 so that it can be
10 screwed down, lowering the cutting element 11 in contact with the cap which then cuts through the bottom of the capsule 3 enabling the powder to mix with the liquid. The cap 13 can then be unscrewed and the mixture dispensed drop by drop through the little central opening in the upper wall of the cutting element 11. Reference will henceforth be made to figures 3 to 6, in which a second
15 embodiment of the invention is illustrated. Some of the elements of the package of the second embodiment are the same as those of the first, for which reason they have been indicated using the same reference numbers.

In the second embodiment the cap 13 is screw-coupled directly on a thread 25 predisposed on the neck of the container 1.

- 20 In the second embodiment, the cutting element 11 is not a single piece with the cap 13, but is made separately.

The capsule 3 exhibits an upper part 21 situated above the upper margin of the mouth of the container 1. The internal diameter of the upper part 21 of the capsule 3 is greater than the external diameter of the cutting element 11 inserted
25 sealedly in the capsule 3. In the assembled configuration of figure 4 (before use) the upper part 21 of the capsule 3 can thus be elastically deformed internalwise. The cutting element 11 exhibits a tract 22 which in use (when the package is to

-7-

be used) is destined to contact the internal surface of the upper part 21 of the capsule, so as to prevent said upper part 21 from being deformed inwardly. An annular projection 23 internal of the cap 13 exhibits an internal diameter which is smaller than the internal diameter of the thread 14. During the downwards axial movement of the capsule 13, this annular projection 23 is destined to engage in an annular recess afforded on the upper part 21 of the capsule 3 so as to constrain the cap 13 and the capsule 3 one to the other in axial upward movement, with which the cap 3 is extracted from the container 1.

Figures 3 and 4 illustrate the package before use.

Whereas the first embodiment included a security strip 16, the package of the second embodiment exhibits a breakable ring 26 coaxially circling the container 1 and situated below the cap 13. The cap 13 and the ring 26 are united by means of easy-break perimeter ribs 27. The ring 26, which has the task of guaranteeing the security of the package, comprises an annular relief 28 coupled with the container 1 in such a way as to prevent or limit axial raising movements of the cap 13. The easy-break ring 26 resists attempts to unscrew and therefore raise the cap 13 (that is, to distance it from the ring 26), while it breaks easily when the cap 13 is lowered. The ring 26 further exhibits an easy-break axial line 29 along which the ring 26 can be opened. In figures 3 and 4 the ring 26 is still unbroken. Figure 5 illustrates the ring 26 open along the axial line 29 and detached from the cap 13.

At the moment of use the ring 26 detaches from the cap 13 and opens by screwing the cap 13 (figure 5). During the screwing-up operation, the cap 13 interacts contactingly with the cutting element 11 so that the latter is pressed downwards, breaking the bottom of the capsule. During this phase the upper annular part 21 of the capsule is deformed inwardly, bringing the internal projection 23 of the cap 13 to engage elastically in the recess 24 on the upper part

-8-

21 of the capsule. This is made possible by the fact that between the elastically-deformable upper annular part 21 of the capsule 3 and the external surface of the cutting element 11 there is a free space. At the end of the cap 13 screwing operation this free space no longer exists, since the above-mentioned tract 22 of cutting element 11 is in contact with the upper part 21 of the capsule. In the subsequent unscrewing phase of the cap 13 the capsule 3, made solid to the cap thanks to the coupling between the projection 23 and recess 24, is raised together with the cutting element 11. During the unscrewing phase the upper tract 22 of the capsule 3 can no longer deform inwardly - as in the screwing phase - since it is forced into contact between the tract 22 of cutting element 11 and the cap 13. The tract 22 of cutting element 11 having the greater diameter has thus the task of keeping the capsule 3 and the cap 13 solidly together during the extraction phase from the container 1.

On packaging, the liquid is poured into the container 1; the powder is placed in the capsule 3 which is then closed by the cutting element 11 with a hermetic and waterproof seal. The assembly is then inserted into the mouth 2 of the container 1. Subsequently the cap 13 is inserted; this is done in such a way that the annular relief 28 is constrained in the annular cavity afforded on the perimeter of the container 1. In this first conformation of the package, illustrated in figures 3 and 4, the conformation in which the package is sold, the cap 13 is solidly anchored to the container 1 and is partially screwed on the container itself. The cap 13 thus has a first function of preventing fraudulent access to the package and handling of the contents of the capsule 3 and the container 1. As has been described, at the moment of use the ring 26 is broken, so that the cap 13 is constrained to the container 1 only by the thread coupling.

The capsule 3 is placed in communication with the container 1 by simply rotating the cap 13, upon which the powders exit and mix with the liquid contents of the

-9-

container 1. As in other known-type packages, a striker is provided to prevent the cutting element 11 from falling into the container 1. On completion of the cap 13 screwing operation the annular projection 23 is inserted into the annular recess 24 afforded on the upper part 21 of the capsule 3.

5 The second function of the cap 13 is to ensure that the above-described operation requires only a minimum effort on the part of the user, who will have no difficulty in performing the mixing operation, as he or she will only have to screw the cap 13. In the second configuration of the package, illustrated in figure 5, the cap 13 is still solidly anchored, thanks to the projection 23 and the recess 24, to
10 the capsule 3 and is free of the container 1, apart, obviously, from the screw coupling.

It is now possible and indeed extremely easy to open the container 1; it is sufficient to unscrew the cap 13, which, translating axially upwards, draws the capsule 3 and the cutting element 11 both constrained thereto. This situation, in
15 which the container 1 is accessible and contains the medicinal substance already mixed, is illustrated in figure 6.

The above details on the packaging and the modalities of use of a configuration of the invention are the same for the other version thereof.

The packages have been described with reference to the pharmaceutical field, but
20 can be used in other fields besides, for example cosmetics, chemistry, food and others, wherever it is necessary to commercialize substances, not necessarily powders and liquids as described herein, but any substances which have to be kept apart until the moment of use.

-10-

Claims.

- 1). A package for keeping products separate before use, comprising:
a container (1) provided with an upper mouth (2);
a capsule (3) inserted internally of the mouth (2) of the container (1), superiorly open, separate from an inside of the container (1), provided with a breakable
5 bottom (4), a rupturing of said breakable bottom (4) setting said capsule (3) in communication with the inside of the container (1);
a cutting element (11) inserted internally of said capsule (3), provided with a bottom end (12) destined in use to break the bottom (4) of the capsule (3);
a cap (13) arranged on the container (1) in such a way as to cover the capsule (3)
10 and the cutting element (11);
wherein the cap (13) exhibits a thread (14) with which a screw-coupling is achieved, by means of which coupling the cap (13) can move axially downwards with respect to the container (1), so that said axial downward movement causes the cap (13) to interact with the cutting element (11) in order to rupture the
15 bottom (4) of the capsule (3).
- 2) The package of claim 1, wherein the cap (13) is screw-coupled with an externally-threaded sleeve (6), predisposed internally of the mouth (2) of the container (1) and solidly constrained to the capsule (3).
- 20
- 3) The package of claim 2, wherein the cap (13) exhibits an annular relief (18) coupled with the sleeve (6) such as to limit upward axial movements of the cap (13).

-11-

4) The package of claim 2 or 3, wherein the sleeve (6) exhibits a striker surface (19) for preventing or limiting downwards axial movements of the cap (13).

5) The package of any one of the claims from 2 to 4, wherein the sleeve (6) exhibits an annular projection (7) coupled with the mouth (2) of the container (1), such as to limit upward axial movements of the sleeve (6).

6) The package of any one of the claims from 2 to 5, wherein the sleeve (6) and the capsule (3) are made in a single piece.

10

7) The package of any one of claims from 2 to 6, comprising means (9, 10) for preventing a rotation of the sleeve (6) with respect to the mouth (2) of the container (1).

8) The package of claim 7, wherein the means (9, 10) for preventing a rotation of the sleeve (6) comprise an annular crown of ribs (9) which engage in respective axial channels.

9) The package of claim 1, wherein the cap (13) is screw-coupled directly on to the neck of the container (1).

10) The package of any one of the preceding claims, wherein the cap (13) internally exhibits an annular projection (23) destined, by effect of said downward axial movement of the cap (13), to engage in an upper annular part (21) of the capsule (3) which is elastically deformable in an internalwise direction, such as to constrain the cap (13) to the capsule (3) in upward axial movements for extraction from the container (1).

-12-

11) The package of claim 10, comprising means for blocking in position the upper part (21) of the capsule (3), which means for blocking intervene after the annular projection (23) has engaged in said upper part (21).

5 **12)** The package of claim 11, wherein said means for blocking said upper part (21) comprise a tract (22) of the cutting element (11) conformed and arranged so as to meet with the internal surface of the upper part (21) of the capsule (3).

10 **13)** The package of any one of the preceding claims, wherein the cap (13) is provided with a removable annular security strip (16) which when removed enables the cap (13) to make said downward axial movement.

15 **14)** The package of claim 13, wherein said removable element comprises an annular security strip (16), removable from the cap (13) along at least one easy-break perimeter line (17).

15) The package of claim 14, wherein said at least one easy-break perimeter line (17) is arranged below an upper edge of the mouth (2) of the container (1).

20 **16)** The package of any one of claims from 1 to 12, comprising a breakable ring (26), predisposed below the cap (13), destined to break by effect of said downward axial movement of the cap (13).

25 **17)** The package of claim 16, wherein said ring (26) can be opened along an easy-break axial line (29).

18) The package of claim 16 or 17, wherein said ring (26) is joined to the cap

-13-

(13) along an easy-break perimeter line.

19) The package of any one of the claims from 16 to 18, wherein the breakable ring (26) exhibits an annular relief (28) coupled with the container (1) in such a way as to prevent or limit upward axial movements of the cap (13).

5

Fig.1

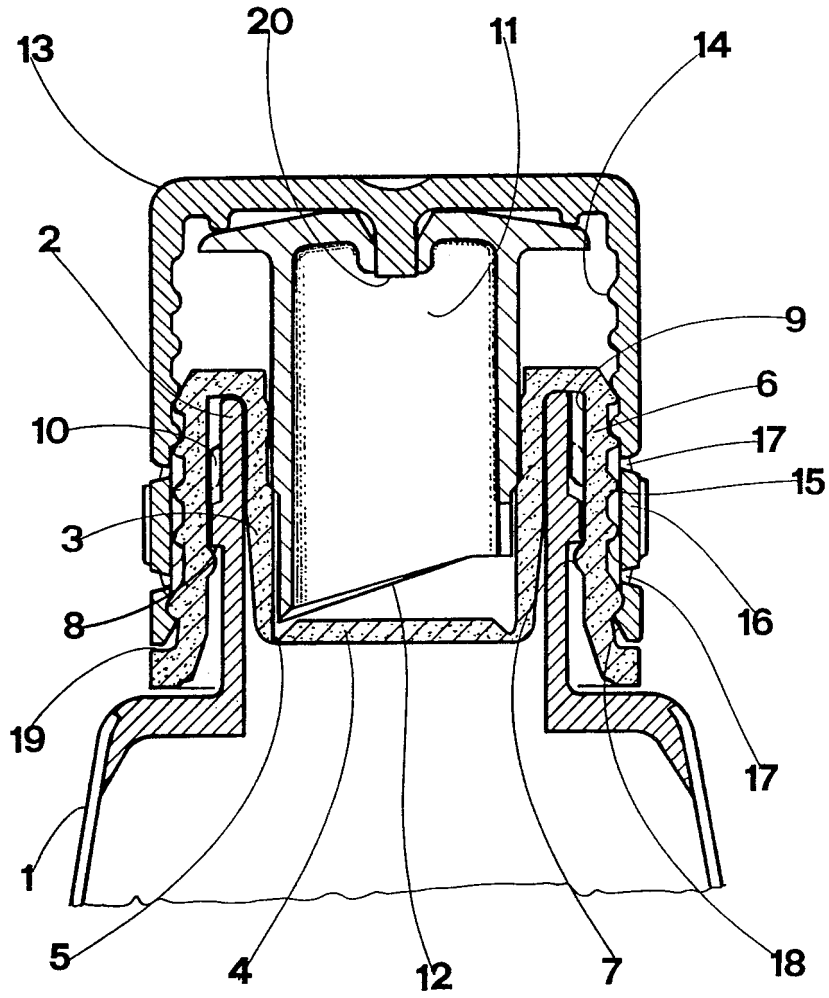

Fig.2

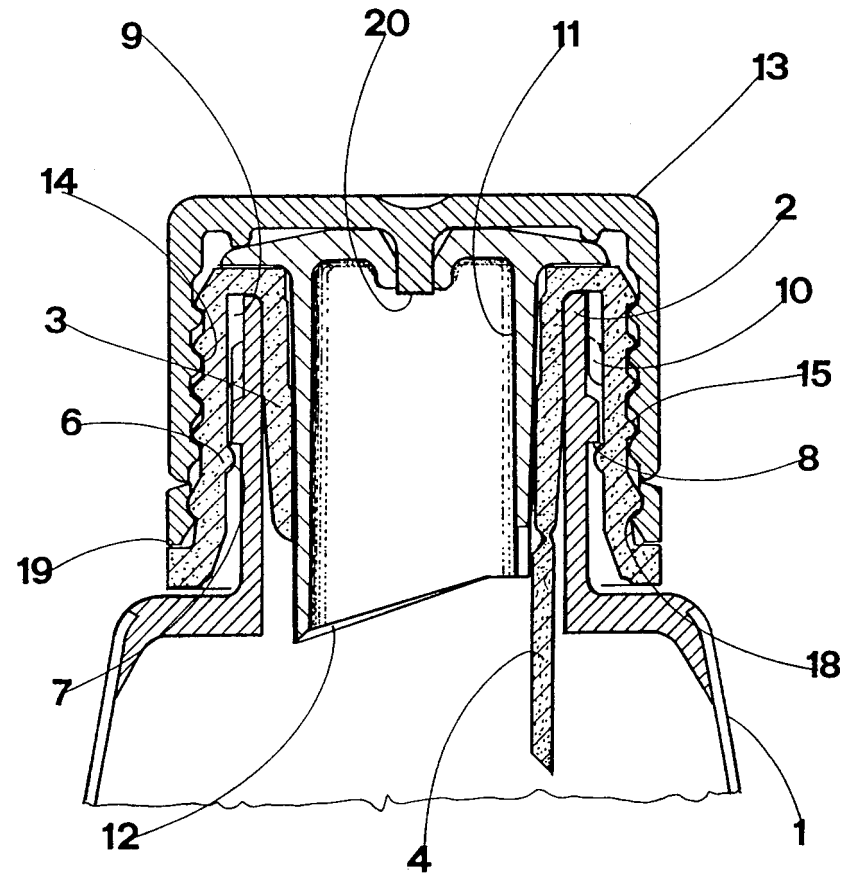

Fig.3

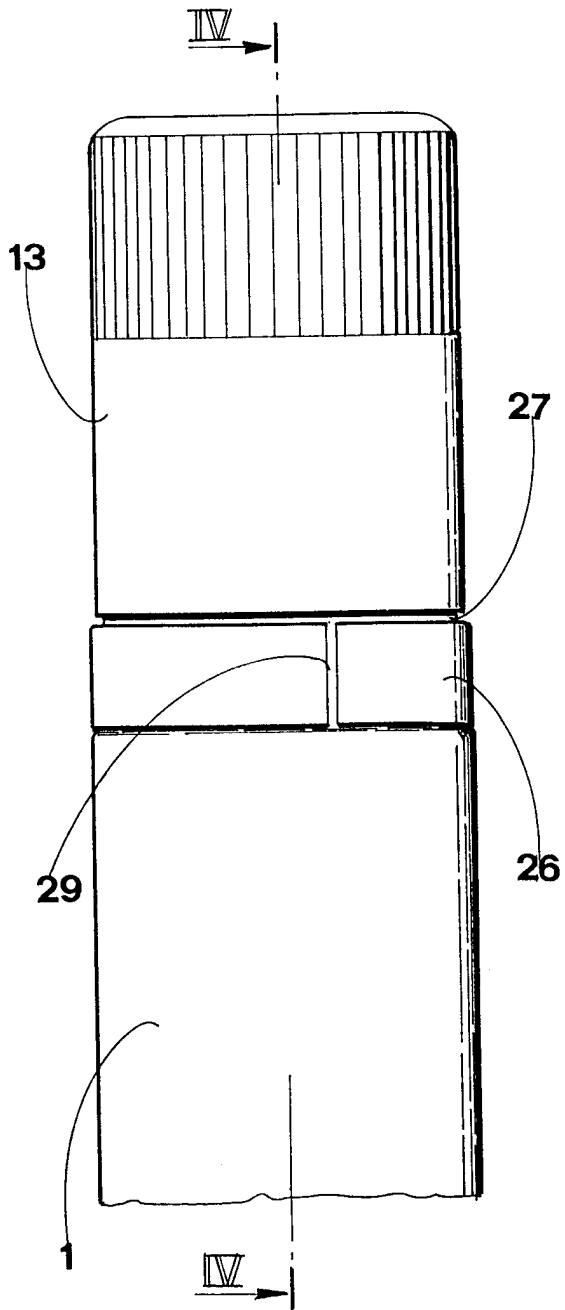
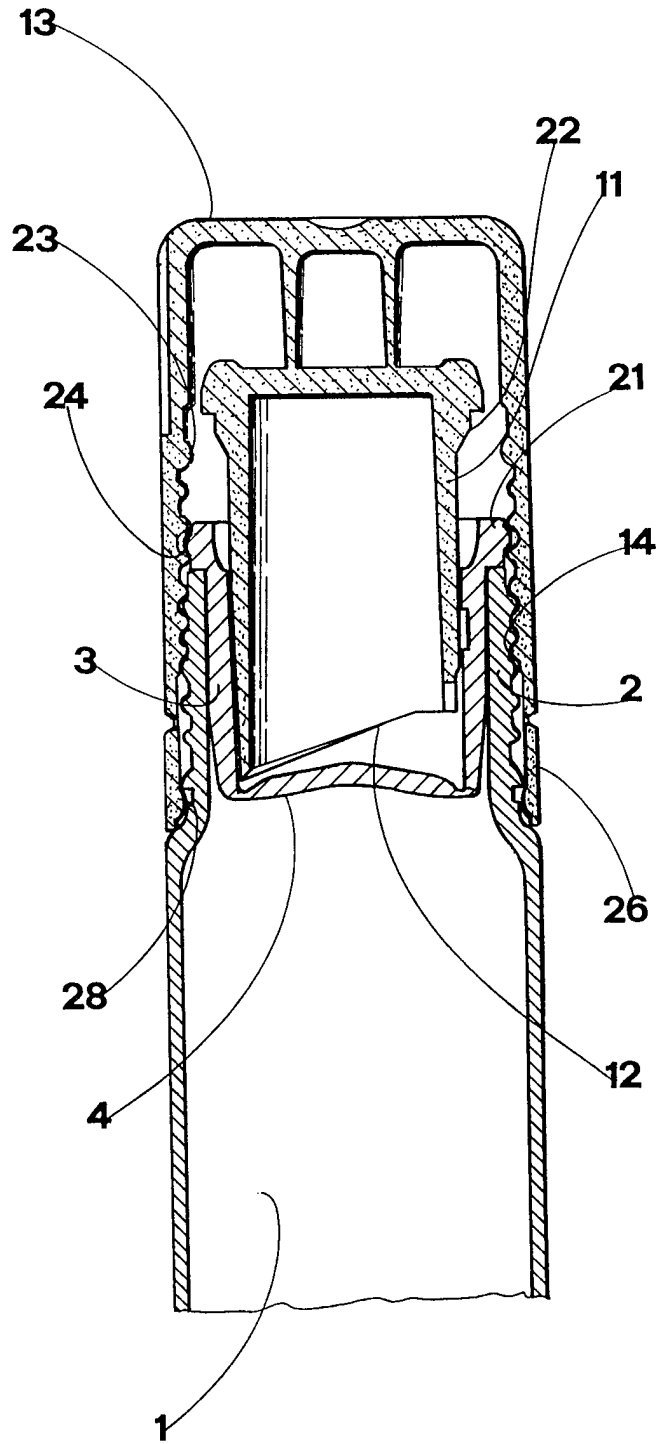

Fig.4



III - III

Fig.6

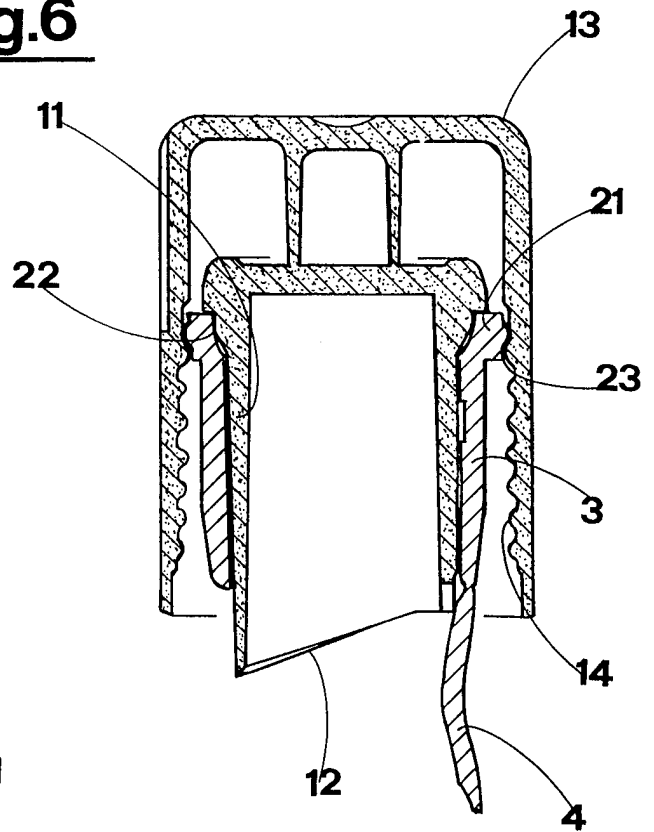
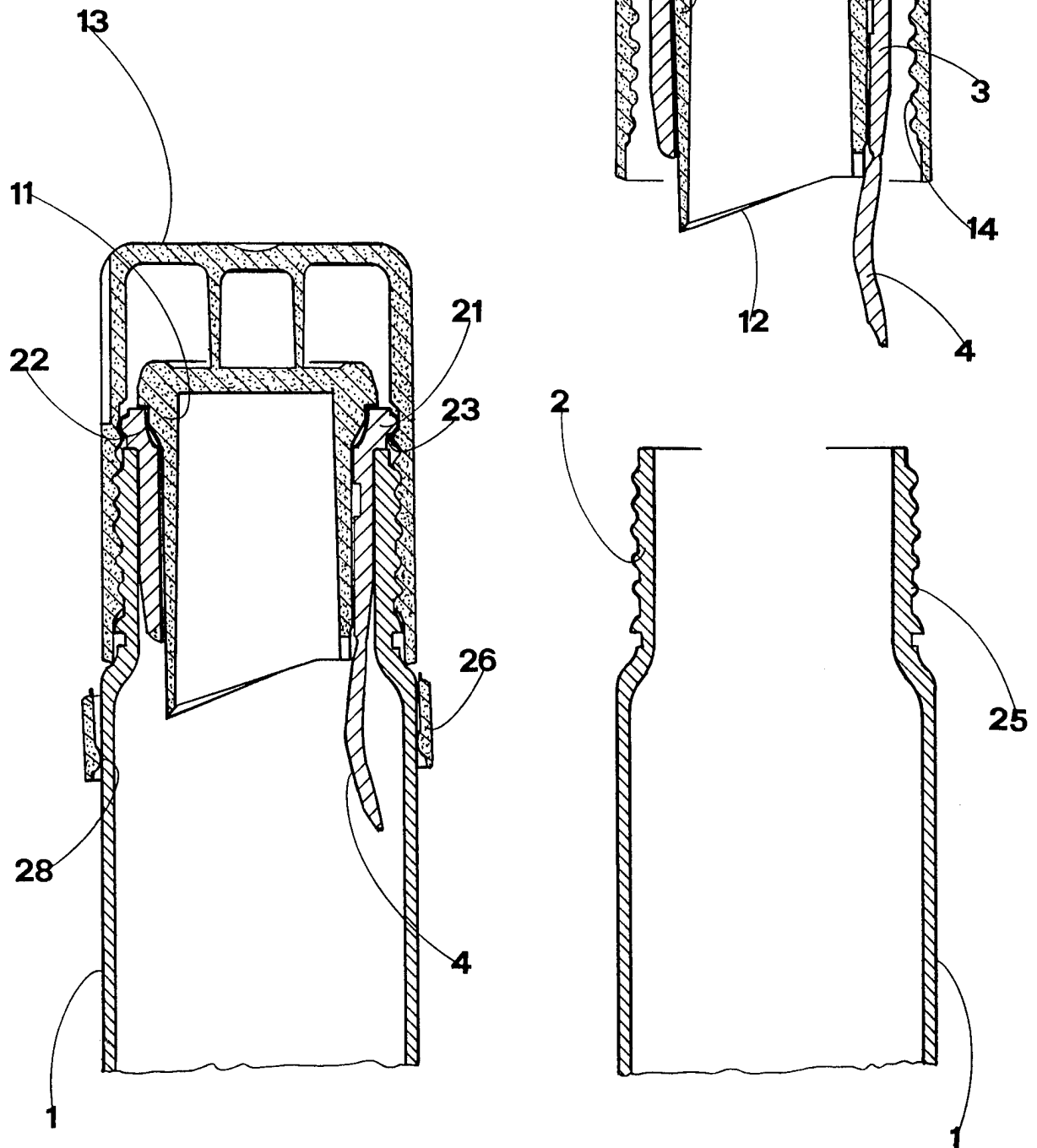

Fig.5



III - III

INTERNATIONAL SEARCH REPORT

Internat. Application No.
PCT/IT 97/00222

A. CLASSIFICATION OF SUBJECT MATTER
IPC 6 B65D51/28

According to International Patent Classification (IPC) or to both national classification and IPC

B. FIELDS SEARCHED

Minimum documentation searched (classification system followed by classification symbols)
IPC 6 B65D

Documentation searched other than minimum documentation to the extent that such documents are included in the fields searched

Electronic data base consulted during the international search (name of data base and, where practical, search terms used)

C. DOCUMENTS CONSIDERED TO BE RELEVANT

Category °	Citation of document, with indication, where appropriate, of the relevant passages	Relevant to claim No.
X	DE 44 10 323 A (HEINLEIN PATRICIA) 28 September 1995	1-8, 10, 13, 14
Y	see the whole document	9, 11, 15-19

Y	US 4 982 875 A (POZZI FRANCO ET AL) 8 January 1991 see column 2, line 21 - column 2, line 37; figures	9, 11, 15-19

A	FR 1 568 362 A (LE NARDOU MICHEL) 23 May 1969 see page 2, line 1 - line 43; figures	1-19

A	US 3 840 136 A (TESTAGUZZA F ET AL) 8 October 1974 see column 3, line 3 - column 4, line 39; figures	1-19

-/--		

Further documents are listed in the continuation of box C.

Patent family members are listed in annex.

° Special categories of cited documents :

- *A* document defining the general state of the art which is not considered to be of particular relevance
- *E* earlier document but published on or after the international filing date
- *L* document which may throw doubts on priority claim(s) or which is cited to establish the publication date of another citation or other special reason (as specified)
- *O* document referring to an oral disclosure, use, exhibition or other means
- *P* document published prior to the international filing date but later than the priority date claimed

- *T* later document published after the international filing date or priority date and not in conflict with the application but cited to understand the principle or theory underlying the invention
- *X* document of particular relevance; the claimed invention cannot be considered novel or cannot be considered to involve an inventive step when the document is taken alone
- *Y* document of particular relevance; the claimed invention cannot be considered to involve an inventive step when the document is combined with one or more other such documents, such combination being obvious to a person skilled in the art.
- *Z* document member of the same patent family

Date of the actual completion of the international search

2 February 1998

Date of mailing of the international search report

25.02.98

Name and mailing address of the ISA

European Patent Office, P.B. 5818 Patentlaan 2
NL - 2280 HV Rijswijk
Tel. (+31-70) 340-2040, Tx. 31 651 epo nl,
Fax: (+31-70) 340-3016

Authorized officer

Olsson, B

INTERNATIONAL SEARCH REPORT

Intern: Application No
PCT/IT 97/00222

C.(Continuation) DOCUMENTS CONSIDERED TO BE RELEVANT

Category °	Citation of document, with indication, where appropriate, of the relevant passages	Relevant to claim No.
A	US 4 195 731 A (CAVAZZA CLAUDIO) 1 April 1980 see column 1, line 37 - column 4, line 12; figures <p style="text-align: center;">-----</p>	1

INTERNATIONAL SEARCH REPORT

Information on patent family members

Internat	l Application No
PCT/IT 97/00222	

Patent document cited in search report	Publication date	Patent family member(s)	Publication date
DE 4410323 A	28-09-95	NONE	
US 4982875 A	08-01-91	CA 1276131 A EP 0217425 A JP 1860362 C JP 62034575 A	13-11-90 08-04-87 27-07-94 14-02-87
FR 1568362 A	23-05-69	NONE	
US 3840136 A	08-10-74	AT 321149 B BE 794915 A CA 1008409 A CH 567978 A DE 2240030 A DE 2363054 A DK 131417 B FR 2170772 A GB 1403274 A JP 48087973 A NL 7301512 A SE 395663 B SE 7301470 A	10-03-75 02-08-73 12-04-77 15-10-75 16-08-73 15-08-74 14-07-75 14-09-73 28-08-75 19-11-73 07-08-73 22-08-77 04-08-73
US 4195731 A	01-04-80	DE 2917281 A FR 2424197 A GB 2019820 A NL 7903308 A	08-11-79 23-11-79 07-11-79 30-10-79