

A&A Ref: 150561

PUBLICATION PARTICULARS AND ABSTRACT
(Section 32(3)(a) - Regulations 22(1)(g) and 31)

21	01	PATENT APPLICATION NO	22	LOGGING DATE	43	ACCEPTANCE DATE
----	----	-----------------------	----	--------------	----	-----------------

2004/5265

1 July 2004

3-10-05

51	INTERNATIONAL CLASSIFICATION	NOT FOR PUBLICATION
----	------------------------------	---------------------

H04B

CLASSIFIED BY: ISA

71	FULL NAME(S) OF APPLICANT(S)
----	------------------------------

LG Electronics Inc.

72	FULL NAME(S) OF INVENTOR(S)
----	-----------------------------

YI, Seung-June
LEE, So-Young

LEE, Young-Dae

EARLIEST PRIORITY CLAIMED	COUNTRY	NUMBER	DATE		
	33	KR 31	10-2002-0057469	32	19 September 2002

NOTE: The country must be indicated by its International Abbreviation - see schedule 4 of the Regulations

54	TITLE OF INVENTION
----	--------------------

Providing multicast services in a point-to-multipoint manner for a radio communication system

57	ABSTRACT (NOT MORE THAN 150 WORDS)
----	------------------------------------

NUMBER OF SHEETS	36
------------------	----

The sheet(s) containing the abstract is/are attached.

If no classification is furnished, Form P.9 should accompany this form.
The figure of the drawing to which the abstract refers is attached.

(12) INTERNATIONAL APPLICATION PUBLISHED UNDER THE PATENT COOPERATION TREATY (PCT)

(19) World Intellectual Property Organization
International Bureau



(43) International Publication Date
1 April 2004 (01.04.2004)

PCT

(10) International Publication Number
WO 2004/028042 A1

- (51) International Patent Classification⁷: H04B 7/26
- (74) Agent: PARK, Jang-Won; Jewoo Bldg. 5th Floor, 200, Nonhyun-Dong, Gangnam-Gu, Seoul 135-010 (KR).
- (21) International Application Number: PCT/KR2003/001920
- (81) Designated States (national): AE, AG, AL, AM, AT, AU, AZ, BA, BB, BG, BR, BY, BZ, CA, CH, CN, CO, CR, CU, CZ, DE, DK, DM, DZ, EC, EE, ES, FI, GB, GD, GE, GH, GM, HR, HU, ID, IL, IN, IS, JP, KE, KG, KP, KZ, LC, LK, LB, LS, LT, LU, LV, MA, MD, MG, MK, MN, MW, MX, MZ, NI, NO, NZ, OM, PG, PH, PL, PT, RO, RU, SC, SD, SE, SG, SK, SL, SY, TJ, TM, TN, TR, TT, TZ, UA, UG, UZ, VC, VN, YU, ZA, ZM, ZW.
- (22) International Filing Date: 19 September 2003 (19.09.2003)
- (25) Filing Language: English
- (26) Publication Language: English
- (30) Priority Data: 10-2002-0057469
19 September 2002 (19.09.2002) KR
- (84) Designated States (regional): ARIPO patent (GH, GM, KE, LS, MW, MZ, SD, SL, SZ, TZ, UG, ZM, ZW), Eurasian patent (AM, AZ, BY, KG, KZ, MD, RU, TJ, TM), European patent (AT, BE, BG, CH, CY, CZ, DE, DK, EE, ES, FI, FR, GB, GR, HU, IE, IT, LU, MC, NL, PT, RO, SE, SI, SK, TR), OAPI patent (BF, BJ, CF, CG, CI, CM, GA, GN, GQ, GW, ML, MR, NE, SN, TD, TG).
- (71) Applicant: LG ELECTRONICS INC. [KR/KR]; 20, Yoido-Dong, Youngdungpo-Gu, Seoul 150-010 (KR).
- (72) Inventors: YI, Seung-June; Daechong Apt. 303-403, Gaepo-Dong, Gangnam-Gu, Seoul 135-940 (KR). LEE, Young-Dae; Sinan Apt. 419-1501, Changwoo-Dong, Hanam, Gyeonggi-Do 465-711 (KR). LEE, So-Young; Twegye 2nd Apt. 366-702, Ogeum-Dong, Gunpo, Gyeonggi-Do 435-758 (KR).

Published:
— with international search report

For two-letter codes and other abbreviations, refer to the "Guidance Notes on Codes and Abbreviations" appearing at the beginning of each regular issue of the PCT Gazette.

(54) Title: PROVIDING MULTICAST SERVICES IN A POINT-TO-MULTIPOINT MANNER FOR A RADIO COMMUNICATION SYSTEM

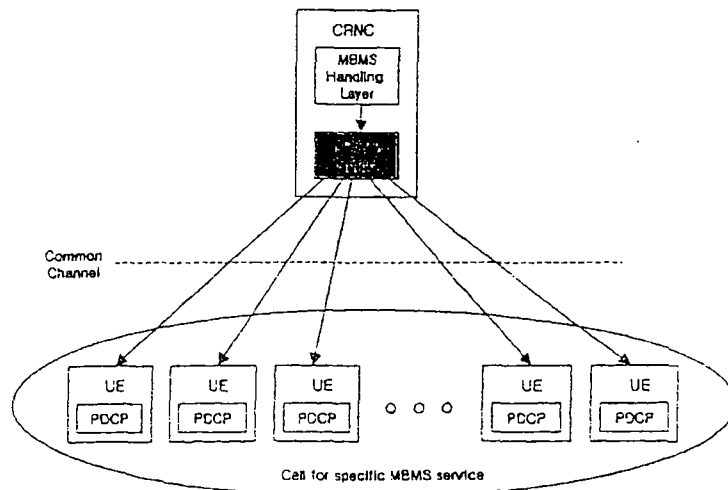

(57) Abstract: Data for a multicast service is provided by a radio communication system by performing header compression and employing a packet data convergence protocol (PDCP) entity that exists for every specific MBMS service to be provided for a cell with users therein. The particular network component (e.g., in a SRNC or a CRNC) that includes one PDCP layer for each specific MBMS service depends upon certain characteristics of the terminals (UE) located within a cell that wish to receive the specific MBMS service. The terminal receives via a common transport channel and restores (i.e., decompresses) the header-compressed data of the MBMS service that was transmitted after header compression at the CRNC, while the terminal receives via a dedicated transport channel and restores (i.e., decompresses) the header-compressed data of the MBMS service that was transmitted after header compression at the SRNC.

WO 2004/028042 A1

**PROVIDING MULTICAST SERVICES IN A POINT-TO-MULTIPOINT
MANNER FOR A RADIO COMMUNICATION SYSTEM**

TECHNICAL FIELD

5

The present invention relates to a multicast service of a mobile communication system and, more particularly, to allowing multicasting of data services in a point-to-multipoint manner using a structure of a PDCP layer suitable for a multimedia broadcast/multicast service (MBMS), and its
10 operation method.

BACKGROUND ART

With the remarkable development in radio mobile communication technology, mobile phones are used more than wired phones. However, for a
15 service providing a large amount of data communications above general voice communications through a radio access network, radio mobile communication technology is behind in its performance compared to that of the existing cable communication system. A communication system enabling a large amount of data communication is called an IMT-2000, for which
20 technological developments and standardization are ongoing in many countries worldwide.

A universal mobile telecommunications system (UMTS), which is a European IMT-2000 system, is a third generation mobile communication

system that has evolved from a standard known as Global System for Mobile communications (GSM). This standard is a European standard which aims to provide an improved mobile communication service based on a GSM core network and wideband code division multiple access (W-CDMA) technology.

5 In December 1998, the ETSI of Europe, the ARIB/TTC of Japan, the T1 of the United States, and the TTA of Korea formed a Third Generation Partnership Project (3GPP) for the purpose of creating the specification for standardizing the UMTS.

The work toward standardizing the UMTS performed by the 3GPP
10 has resulted in the formation of five technical specification groups (TSG), each of which is directed to forming network elements having independent operations.

More specifically, each TSG develops, approves and manages a standard specification in a related region. Among them, a radio access
15 network (RAN) group (TSG-RAN) develops a specification for the function, items desired, and interface of a UMTS terrestrial radio access network (UTRAN), which is a new RAN for supporting a W-CDMA access technology in the UMTS.

Figure 1 shows a network structure of a general UMTS.

20 As shown in Figure 1, the UMTS is roughly divided into a terminal (UE: user equipment), a UTRAN and a core network.

The UTRAN includes one or more radio network sub-systems (RNS). Each RNS includes an RNC and one or more Node Bs managed by the

RNCs.

Node Bs are managed by the RNCs, receive information sent by the physical layer of a terminal (e.g., mobile station, user equipment and/or subscriber unit) through an uplink, and transmit data to a terminal through a downlink. Node Bs, thus, operate as access points of the UTRAN for a terminal.

The RNCs perform functions, which include assigning and managing radio resources, and operate as an access point with respect to the core network.

Each terminal connected to the UMTS network is managed by a specific RNC in the UTRAN, and this RNC is called an SRNC (Serving RNC). The SRNC serves as an access point to the core network in order to transmit data of a specific terminal, and allocates a radio resource suitable for providing a service.

The terminal connected to the core network through the UTRAN has only one SRNC. In general, one RNC is used for connection between the terminal and the RNC, but if the terminal moves into a region managed by a different RNC, it is connected to an SRNC by way of an RNC of the region in which the terminal has moved. Except for the SRNC, every RNC that the terminal goes through is called a DRNC (Drift RNC), and the DRNC performs a simple partial function of routing user data or assigning a code, which is a common resource. That is, the discrimination of the SRNC and the DRNC is a logical discrimination related to a specific terminal.

Meanwhile, the RNC can be discriminated at the Node B according to a dependent relation of the RNC and the Node B in the UTRAN. An RNC which handles managing of a specific Node B is called a CRNC (Controlling RNC), and the CRNC performs functions of controlling a traffic load and congestion in a cell that the CRNC itself manages and a function of controlling acceptance of a new radio link set in the cell. In terms of the structure of the UTRAN, each Node B necessarily has only one CRNC.

The services provided to the specific terminal 10 is roughly divided into a circuit switched service and a packet switched service. For example, a general voice phone call service belongs to the circuit switched service, while a Web browsing service through an Internet connection is classified as the packet switched service.

In case of supporting the circuit switched service, the RNC 20 is connected to the MSC 31 of the core network 30, and the MSC 31 is connected to a GMSC (Gateway Mobile Switching Center) 33 managing a connection to other networks.

Meanwhile, in case of the packet switched service, services are provided by a SGSN (Serving GPRS Support Node) 35 and a GGSN (Gateway GPRS Support Node) 37 of the core network 30.

The SGSN 35 supports a packet communication going toward the RNC 23, and the GGSN 37 manages connections to other packet switched networks such as the Internet.

An interface exists between various network components to allow the

network components to give and take information to and from each other to allow mutual communication. A cable interface between the RNC 23 and the core network 30 is defined as an Iu interface. Connection of the Iu interface to the packet switched area is defined as an Iu-PS, and connection of the Iu interface to the circuit switched area is defined as an Iu-CS.

Figure 2 illustrates a structure of a radio access interface protocol between a terminal and the UTRAN on the basis of 3GPP radio access network standard.

As shown in Figure 2, the radio access interface protocol includes horizontal layers comprising a physical layer, a data link layer and a network layer, and vertical planes comprising a user plane for transmitting data information and a control plane for transmitting control signals.

The user plane is a region to which traffic information of a user such as voice or an IP packet is transmitted. The control plane is a region to which control information such as an interface of a network or maintenance and management of a call is transmitted.

In Figure 2, the protocol layers can be divided into L1 (a first layer), L2 (a second layer), and L3 (a third layer) based on three lower layers of an open system interconnection (OSI) standard model well known in the art of communication systems.

The L1 layer provides an information transfer service to the second layer, (which is an upper layer) by using various radio transfer techniques. The L1 layer is connected to the MAC layer through a transport channel, and

data is transferred between the MAC layer and the PHY layer through the transport channel.

The L2 layer includes a medium access control (MAC) layer, a radio link control (RLC) layer, a packet data convergence protocol (PDCP) layer
5 and a broadcast/multicast control (BMC) layer.

The MAC layer handles a mapping between the logical channel and the transport channel, and provides a re-allocation service of the MAC parameter for allocation and re-allocation of radio resources.

The MAC layer is connected to the radio link control (RLC) layer
10 (which is an upper layer) through a logical channel, and various logical channels are provided according to the kind of transmitted information.

In general, when information of the control plane is transmitted, a control channel is used. When information of the user plane is transmitted, a traffic channel is used.

15 The MAC layer is connected to the physical layer (which is a lower layer) through the transport channel, and as the transport channel, a common channel or a dedicated channel is used depending upon whether the channel is shared or not.

The MAC layer is divided into a MAC-b sublayer, a MAC-d sublayer,
20 and a MAC-c/sh sublayer, according to the type of transport channel being managed. The MAC-b sublayer manages a broadcast channel (BCH) handling the broadcast of various data and system information, while the MAC-c/sh sublayer manages a shared transport channel such as a forward

access channel (FACH), a downlink shared channel (DSCH), or the like, being shared with other terminals.

In the UTRAN, the MAC-c/sh sublayer is located in a control RNC (CRNC) and manages channels shared by all terminals in a cell, so that one
5 MAC-c/sh sublayer exists for each cell. A MAC-c/sh sublayer also exists in each terminal 10, respectively.

The MAC-d sublayer manages a dedicated channel (DCH), which is a dedicated transport channel for a specific terminal 10. Accordingly, the MAC-d sublayer is located in a serving RNC (SRNC) that manages a
10 corresponding terminal 10, and one MAC-d sublayer also exists in each terminal 10.

A radio link control (RLC) layer provides support for reliable data transmissions, and may perform a function of segmentation and concatenation of an RLC service data unit (SDU) coming from a higher layer.
15 The RLC SDU transferred from the higher layer is adjusted in its size according to a throughput capacity at the RLC layer, to which header information is added, and is then transferred to the MAC layer in the form of a protocol data unit (PDU). The RLC layer includes an RLC buffer for storing the RLC SDU or the RLC PDU coming from the higher layer.

20 A packet data convergence protocol (PDCP) layer is located at an upper layer from the RLC layer, allowing data to be transmitted effectively on a radio interface with a relatively small bandwidth through a network protocol, such as the IPv4 or the IPv6. For this purpose, the PDCP layer performs the

function of reducing unnecessary control information used in a wired network, and this function is called header compression. These methods allow transmission of only the absolutely necessary information required in the header part of a data, and thus transmitting a smaller amount of control
5 information can reduce the overall amount of data to be transmitted.

A broadcast / multicast control (BMC) layer schedules a cell broadcast (CB) message transferred from the core network and transmits the cell broadcast message to a specific cell, whereby every terminal positioned in the cell perform the cell broadcast message. Especially, the BMC layer is
10 used for handling only the broadcast function, and the CB message is a short message consisting of a maximum 1230 octets which only include characters and numbers transmitted between terminals or between a terminal and a system.

At the UTRAN 100, the CB message transferred from the upper layer
15 is combined with information, such as a message ID (identification), a serial number, a coding scheme, etc., and transferred to the RLC layer in the form of a BMC message. The BMC message is transmitted to the MAC layer through a common traffic channel (CTCH), which is a logical channel. Here, the logical channel CTCH is mapped to a FACH transport channel, and the
20 FACH transport channel is mapped to a physical channel, that is, a secondary common control physical channel (S-CCPCH).

The radio resource control (RRC) layer located at the lowest portion of the third layer (L3) is only defined in the control plane, and controls the

transport channels and the physical channels in relation to the setup, the reconfiguration, and the release (cancellation) of the radio bearers (RBs). Here, the RB signifies a service provided by the second layer (L2) for data transmission between the terminal 10 and the UTRAN 100. In general, the set up of the RB refers to the process of stipulating the characteristics of a protocol layer and a channel required for providing a specific data service, and setting the respective detailed parameters and operation methods.

The RLC layer may be part of the user plane or the control plane in accordance with an upper layer connected thereto. The RLC layer is part of the control plane when data is received from the RRC layer, and the RLC layer is part of the user plane in all other instances.

As can be understood from Figure 2, regarding the RLC layer and the PDCP layer, a plurality of entities may exist in a single layer thereof. This is because one terminal may have many radio (wireless) carriers, and typically, only one RLC entity and one PDCP entity is used for each radio bearer.

However, the cell broadcast service provided by the existing BMC layer does not only support a multicast function but also have limitations in providing a multimedia service, because it can transmit only a short message with a maximum size of 1230 octets. For this reason, a new service called a multimedia broadcast/multicast service (MBMS) has been proposed.

As shown in Figure 3, the MBMS is a service for simultaneously transmitting multimedia data such as audio, video or image data to a plurality

of terminals by using a uni-directional point-to-multipoint bearer service, which supports a broadcast mode and a multicast mode.

The MBMS is divided into a broadcast mode and a multicast mode. That is, the MBMS is divided into an MBMS broadcast service and an MBMS
5 multicast service.

The MBMS broadcast mode is a service for transmitting multimedia data to every user in a broadcast area. The broadcast area means an area in which a broadcast service is available. One or more broadcast areas may exist in one PLMN, one or more broadcast services can be provided in one
10 broadcast area, and one broadcast service can be provided to several broadcast areas.

The MBMS multicast mode is a service for transmitting multimedia data only to a specific user group existing in a multicast area. The multicast area means an area in which a multicast service is available. One or more
15 multicast areas can exist in one PLMN (public land mobile network), one or more multicast services can be provided in one multicast area, and one multicast service can be provided to several multicast areas.

In general, the MBMS is a service for broadcasting or multicasting multimedia data and the size of a transmitted packet is considerably large.
20 Thus, by compressing a header portion occupying a large part of a packet in the MBMS by using a header compression technique, data transmission efficiency can be improved. Because the MBMS is a uni-directional point-to-multipoint service, a header compressor in the UTRAN at a sending end

transmits the same data to header decompressors in the terminals at a receiving end.

As mentioned above, the MBMS can improve data transmission efficiency by compressing the header part of multimedia data by using the header compression technique.

In the conventional art, as shown in Figure 4, the PDCP layer handling the header compression is positioned at the SRNC of a specific terminal and of UTRAN, and at this time, a compressed packet is transmitted and received through a dedicated transport channel.

In other words, as for the MBMS service provided according to the conventional art, a header part of MBMS data is compressed in a PDCP layer of the SRNC managing a resource of a specific terminal and transmitted to a terminal through the dedicated transport channel.

In this case, because the MBMS service has characteristics of simultaneously broadcasting and multicasting the same data to a plurality of terminals, the number of PDCP entities existing at the SRNC is equal to the number of terminals in a cell for every type of MBMS service.

However, because the MBMS data transmitted after being compressed in the PDCP layer of the SRNC have the same content, the repetitive PDCP entities existing at the SRNC considerably wastes the resources of the UTRAN system and radio resources.

DISCLOSURE OF THE INVENTION

Therefore, an object of the present invention is to provide a PDCP structure capable of allowing a resource of a UTRAN system and a radio
5 resource to be effectively used.

Another object of the present invention is to provide a PDCP structure in which every specific MBMS service has one PDCP entity for a cell.

Still another object of the present invention is to provide a PDCP
10 structure in which a PDCP layer is provided in a CRNC and to provide a data transmission method thereof.

To achieve at least the above objects in whole or in part, there is provided a PDCP structure in a wireless system which compresses a header of multimedia service data and multicasts it through a downlink, wherein an
15 entity handling a header compression of multimedia service data is positioned in a control center which manages a common resource of multiple terminals of a cell.

Preferably, the entity is a packet data convergence protocol (PDCP) entity.

20 Preferably, only one entity exists for every specific MBMS service for one cell.

Preferably, the control center is a control radio network controller (CRNC).

Preferably, the header-compressed data is transmitted to a terminal through a common channel, and the common channel is a forward access channel (FACH) or a downlink shared channel (DSCH).

To achieve at least these advantages in whole or in part, there is further provided a radio mobile communication system including: a radio network controller (RNC) for performing a header compression function on multimedia service data; and a plurality of terminals for receiving the header-compressed multimedia service data from the RNC through a common transport channel.

Preferably, the multimedia service is a multimedia broadcast/multicast service (MBMS).

Preferably, the RNC is a control RNC (CRNC) that manages a common resource for multiple terminals.

Preferably, the RNC includes an MBMS handling layer for outputting multimedia data to be transmitted; and a packet data convergence protocol (PDCP) layer for compressing a header of multimedia data.

Preferably, the PDCP layer includes one entity for every specific multimedia service in one cell.

To achieve at least these advantages in whole or in part, there is further provided a data transmission method in a wireless system for compressing a header of multimedia service data and multicasting it through a downlink, including: compressing a header of multimedia service data; and transmitting the header-compressed multimedia service data to plural

terminals through a common transport channel.

Preferably, the multimedia service is a multimedia broadcast/multicast service (MBMS).

Preferably, the header compression is performed at a packet data
5 convergence protocol (PDCP) layer, and the PDCP layer exists in a control radio network controller (CRNC).

Preferably, the PDCP layer includes one entity for every specific MBMS service in one cell.

Preferably, the particular network component (e.g., in a SRNC or a
10 CRNC) that includes the PDCP layer for a specific MBMS service depends upon certain characteristics of the terminals (UE) located within a cell that wish to receive the specific MBMS service.

Additional advantages, objects, and features of the invention will be set forth in part in the description which follows and in part will become
15 apparent to those having ordinary skill in the art upon examination of the following or may be learned from practice of the invention. The objects and advantages of the invention may be realized and attained as particularly pointed out in the appended claims.

20

BRIEF DESCRIPTION OF THE DRAWINGS

The invention will be described in detail with reference to the following drawings in which like reference numerals refer to like elements

wherein:

Figure 1 illustrates a structure of a network of a general UMTS system;

Figure 2 illustrates a structure of a radio access interface protocol
5 between a terminal and UTRAN on the basis of the 3GPP radio access network standards;

Figure 3 illustrates a concept of transmission of a general MBMS data;

Figure 4 illustrates a protocol stack for transmission of MBMS data in
10 accordance with a conventional art;

Figure 5 illustrates a network structure for transmission of the MBMS in accordance with the conventional art;

Figure 6 illustrates a protocol stack for transmission of MBMS data in accordance with an embodiment of the present invention; and

15 Figure 7 illustrates a network structure for transmission of the MBMS in accordance with an embodiment of the present invention.

MODES FOR CARRYING OUT THE PREFERRED EMBODIMENTS

The present invention is implemented in a mobile communication
20 system such as a UMTS (Universal Mobile Telecommunications System) developed by 3GPP. However, the present invention can be also applied to a communication system opening in a different standard.

Referring back to the related art, if MBMS data is header-

compressed and transmitted, the number of required PDCP entities must equal the total number of terminals for every specific MBMS service to be provided. Accordingly, system resources of the UTRAN and various radio resources are wasted.

5 In order to address such problems, the inventors of the present invention considered the characteristics of providing MBMS, such as MBMS data being simultaneously transmitted to a plurality of terminals, and provided a solution to related art problems by providing a PDCP layer that handles header compression in the CRNC. That is, as shown in the protocol stack
10 shown in Figure 6, the PDCP is provided above the RLC layer, which is above the MAC layer at the CRNC.

 In addition, in the present invention, MBMS data with a header compressed in a single PDCP layer within the CRNC, is transmitted to a terminal through the common transport channel. The common transport
15 channel is a forward access channel (FACH) or a downlink shared channel (DSCH).

 Figure 7 illustrates a network structure for the transmission of the MBMS data in accordance with an embodiment of the present invention.

 As shown in Figure 7, when the PDCP layer, which compresses a
20 header of MBMS data, exists at the CRNC, only one PDCP entity is required for each specific MBMS service in a cell irrespective of the number of terminals. That is, in the present invention, a radio (wireless) system is implemented such that one PDCP entity exists per cell in UTRAN for a

specific MBMS service. Furthermore, each UE has its own PDCP entity for a specific MBMS service. Thus, for a specific MBMS service, if there are plural terminal which desires to receive the service, one PDCP entity in UTRAN is associated with plural PDCP entities that belong to the terminals.

5 Accordingly, for transmission of MBMS data, the MBMS handling layer of CRNC transmits the MBMS data to the PDCP layer, and then, the PDCP layer compresses a header of the received MBMS data and then transmits to a plurality of terminals, which desire to receive the specific MBMS data, through the common transport channel. Each PDCP layer of
10 each terminal decompresses the received MBMS data and transmits it to the MBMS handling layer.

 Also regarding Figure 7, it can be noted that an embodiment of the present invention pertains to a method for providing multicast services in a radio communication system, the method performed by a network component,
15 such as a radio network controller (RNC), comprises the steps of performing Internet protocol header compression to form header compressed data, and transmitting the header compressed data in a point-to-point manner and in a point-to-multipoint manner depending upon a threshold value, to one or more users of the radio communication system.

20 Alternatively, a method for providing multicast services according to the present invention comprises the steps of performing Internet protocol header compression to form header compressed data, and transmitting the header compressed data in a point-to-multipoint manner according to a type

of multicast service to one or more users in the radio communication system.

Here, the Internet protocol header compression is respectively performed for each type of multicasting service to be provided. Also, the header compression is performed at a central location for each type of
5 multicast service, wherein the central location is a packet data convergence protocol (PDCP) entity, and the PDCP entity is located within a controlling radio network controller (CRNC).

Also, it should be noted that the header-compressed data can be selectively transmitted in a point-to-point manner, in a point-to-multipoint
10 manner, or both. The manner of transmission depends upon the conditions of the radio communication environment. For example, the point-to-point manner is employed if a total number of users within a cell is below the threshold value, while the point-to-multipoint manner is employed if a total number of users within a cell is at or above the threshold value.

15 The point-to-point manner is transmitting data from a single sending point to a single receiving point, which may be based upon a total number of users within a cell of the radio communication system.

Preferably, the point-to-point manner is performed in a serving radio network controller (SRNC). Here, the transmitting by point-to-point manner is
20 via a dedicated channel. In contrast, the point-to-multipoint manner is performed in a controlling radio network controller (CRNC). Here, the transmitting by point-to-multipoint manner is via a common channel.

Based upon the above, it can be understood that a method for

receiving multicast services at a user equipment (UE) can be performed with appropriate steps and procedures that oppose those steps and procedures used for providing (transmitting) the multicast service.

As so far described, in the present invention, when MBMS data
5 having point-to-multipoint characteristics is header-compressed and transmitted, the PDCP layer for the MBMS is positioned at the CRNC, so that one PDCP entity exists for every specific MBMS service in a cell. In addition, the MBMS data with a header compressed in one PDCP entity is transmitted to the terminal through the common transport channel.

10 Accordingly, adopting the PDCP structure and the transmission method of the present invention resolves the problems of the related art in which the PDCP entities are repetitively provided for every specific MBMS service in a cell, each PDCP being provided in the SRNC and transmitted via a dedicated transport channel. Thus, waste of system resources of the
15 UTRAN and radio resources can be prevented and transmission efficiency can be improved.

It should be noted that the particular network component (e.g., in a SRNC or a CRNC) that includes the PDCP layer for a specific MBMS service depends upon certain characteristics of the terminals (UE) located within a
20 cell that wish to receive the specific MBMS service. For example, the characteristic of the terminals (UE) may be the total number of terminals (UE) wishing to receive the specific MBMS service. Namely, if the total number of terminals is equal to or greater than a threshold value, header compression is

performed (at the PDCP layer) in a CRNC that manages shared resources within a cell, and downlink data transmission via a common transport channel is performed. If the total number is less than the threshold, header compression is performed (at the PDCP layer) in a SRNC that manages
5 dedicated resources, and downlink data transmission via a dedicated transport channel is performed.

Thus, depending upon the total number of terminals within a cell, a terminal can receive via a common transport channel and restores (i.e., decompresses) the header-compressed data of the MBMS service that was
10 transmitted after header compression at the CRNC, while a terminal can receive via a dedicated transport channel and restores (i.e., decompresses) the header-compressed data of the MBMS service that was transmitted after header compression at the SRNC.

Here, it can be understood that other characteristics, besides the
15 total number of terminals may also be employed as needed.

The foregoing embodiments and advantages are merely exemplary and are not to be construed as limiting the present invention. The present teaching can be readily applied to other types of apparatuses. The description of the present invention is intended to be illustrative, and not to
20 limit the scope of the claims. Many alternatives, modifications, and variations will be apparent to those skilled in the art.

CLAIMS

1. A method for providing multicast services in a radio communication system, the method comprising:

5 performing Internet protocol header compression to form header compressed data; and

transmitting the header compressed data in a point-to-point manner and in a point-to-multipoint manner depending upon a threshold value, to one or more users of the radio communication system.

10

2. The method of claim 1, wherein the point-to-point manner is employed if a total number of users within a cell is below the threshold value.

3. The method of claim 1, wherein the point-to-multipoint manner is
15 employed if a total number of users within a cell is at or above the threshold value.

4. The method of claim 1, wherein the Internet protocol header compression is respectively performed for each type of multicasting service
20 to be provided.

5. The method of claim 1, wherein the point-to-point manner is transmitting data from a single sending point to a single receiving point.

6. The method of claim 5, wherein the point-to-point manner is based upon a total number of users within a cell of the radio communication system.

5 7 The method of claim 5, wherein the point-to-point manner is performed in a serving radio network controller (SRNC).

8. The method of claim 7, wherein the transmitting by point-to-point manner is via a dedicated channel.

10

9. The method of claim 1, wherein the point-to-multipoint manner is transmitting data from a single sending point to multiple receiving points.

10. The method of claim 9, wherein the point-to-multipoint manner is
15 based upon a total number of users within a cell of the radio communication system.

11. The method of claim 9, wherein the point-to-multipoint manner is performed in a controlling radio network controller (CRNC).

20

12. The method of claim 11, wherein the transmitting by point-to-multipoint manner is via a common channel.

13. The method of claim 1, wherein the header compression is performed at a central location for each type of multicast service.

14. The method of claim 13, wherein the central location is a packet
5 data convergence protocol (PDCP) entity.

15. The method of claim 14, wherein the PDCP entity is located within a controlling radio network controller (CRNC).

10 16. The method of claim 1, wherein a multicast service is a service that is provided to a specified plurality of users.

17. The method of claim 16, wherein the multicast service is multimedia broadcast / multicast service (MBMS).

15

18. A method of receiving data of a multicast service in a radio communication system, the method comprising:

receiving header compressed data in a point-to-point manner and in a point-to-multipoint manner depending upon a threshold value; and

20 decompressing the received header compressed data to allow a user to access the multicast service.

19. The method of claim 18, wherein the point-to-point manner is

receiving data by a single receiving point from a single sending point.

20. The method of claim 19, wherein the point-to-point manner is based upon a total number of users within a cell of the radio communication
5 system.

21. The method of claim 19, wherein the receiving by point-to-point manner is via a dedicated channel.

10 22. The method of claim 18, wherein the point-to-multipoint manner is receiving data by multiple receiving points from a single sending point.

23. The method of claim 22, wherein the point-to-multipoint manner is based upon a total number of users within a cell of the radio
15 communication system.

24. The method of claim 22, wherein the receiving by point-to-multipoint manner is via a common channel.

20 25. The method of claim 18, wherein a multicast service is a service that is received by a specified plurality of users.

26. The method of claim 25, wherein the multicast service is

multimedia broadcast / multicast service (MBMS).

27. The method of claim 18, wherein the header decompressing is performed at a packet data convergence protocol (PDCP) entity.

5

28. In a radio communication system for providing and receiving data of a multicast service, a radio network controller comprising:

a header compressing portion that performs Internet protocol header compression; and

10 a transmitting portion, operatively connected with the header compressing portion, that transmits the header compressed data in point-to-point manner and in a point-to-multipoint manner depending upon a threshold value, to one or more users of the radio communication system.

15 29. The radio network controller of claim 28, wherein the header compressing portion is a packet data convergence protocol (PDCP) entity.

30. The radio network controller of claim 28, wherein the header compressing portion respectively performs header compression for each type
20 of multicasting service to be provided.

31. The radio network controller of claim 29, wherein the transmitting portion is a serving radio network controller (SRNC).

32. The radio network controller of claim 31, wherein the SRNC transmits via a dedicated transport channel.

5 33. The radio network controller of claim 29, wherein the transmitting portion is a controlling radio network controller (CRNC).

34. The radio network controller of claim 33, wherein the CRNC transmits via a common transport channel.

10

35. In a radio communication system for providing and receiving data of a multicast service, a user equipment comprising:

a receiving portion, that receives in a point-to-point manner and in a point-to-multipoint manner, Internet protocol header compressed data; and

15 a header decompressing portion, operatively connected with the receiving portion, that decompresses the header compressed data to access the multicast service.

36. The user equipment of claim 35, wherein the header decompressing portion is a packet data convergence protocol (PDCP) entity.

20

37. The user equipment of claim 35, wherein the header compressing portion respectively performs Internet protocol header

compression for each type of multicasting service to be provided.

38. The user equipment of claim 35, wherein the receiving portion receives the data in a point-to-point manner from a serving radio network controller (SRNC).
5

39. The user equipment of claim 38, wherein the receiving portion receives via a dedicated transport channel.

40. The user equipment of claim 35, wherein the receiving portion receives the data by a point-to-point manner from a serving radio network controller (CRNC).
10

41. The user equipment of claim 40, wherein the receiving portion receives via a common transport channel.
15

42. A method for providing multicast services in a radio communication system, the method comprising:

performing Internet protocol header compression to form header compressed data; and
20

transmitting the header compressed data in a point-to-multipoint manner according to a type of multicast service to one or more users in the radio communication system.

43. A method of providing data including at least one header to a plurality of terminals in a wireless communication system, the method comprising the steps of:

performing compression of at least part of the at least one header to form a compressed header in a header compression module (PDCP) in a network communicating with the plurality of terminals; and

transmitting the data comprising the compressed header to at least one terminal of the wireless communication system, wherein the number of terminals is greater than the number of header compression modules in the network.

44. The method of claim 43, wherein the header is an Internet protocol header.

45. The method of claim 43, wherein the data comprising the compressed header is transmitted to the plurality of terminals using a common channel.

46. The method of claim 43, wherein the data comprising the compressed header is transmitted to the plurality of terminals in one of a point-to-point and a point-to-multipoint manner.

47. The method of claim 46, wherein the selection of one of the point-to-point manner and the point-to-multipoint manner is determined using a predetermined requirement associated with a number of terminals communicating with the network.

48. The method of claim 43, wherein at least part of the data comprising the compressed header is not compressed by the header compression module.

49. The method of claim 43, wherein the header compression module is associated with a packet data convergence protocol layer of the network.

50. The method of claim 43, wherein the header compression module is associated with a controlling radio network controller.

51. A method of providing Internet protocol header information to a plurality of users in a wireless communication system, the method comprising the steps of:

performing header compression of Internet protocol header information to form compressed header data; and

transmitting the compressed header data to at least one user of the communication system in one of a point-to-point manner and a point-to-multipoint manner depending upon a threshold value.

52. The method of claim 51, wherein header compression is performed once for the data transmitted to a plurality of users when the data is transmitted in a point-to-multipoint manner.

53. The method of claim 51, wherein the compressed header data is provided to a plurality of users when the data is transmitted in a point-to-multipoint manner.

54. The method of claim 51, wherein the threshold value is associated with a number of terminals.

55. The method of claim 51, wherein the compressed header data is transmitted to the at least one user using a common channel.

56. The method of claim 51, wherein at least part of the Internet protocol header information is not compressed.

57. The method of claim 51, wherein the header compression is performed at a packet data convergence protocol layer.

58. The method of claim 51, wherein the header compression is performed at a controlling radio network controller.

59. A method of providing internet protocol header information to a plurality of terminals in a wireless communication system, the method comprising the steps of:

performing compression of internet protocol header information to form compressed header data and providing the compressed header data on a common logical channel (CTCH);

transmitting the compressed header data to a plurality of terminals in a point-to-multipoint manner wherein the compressed header data is mapped to a

common physical channel (S-CCPCH) accessible by a plurality of terminals; and receiving and decompressing the compressed header data on the common physical channel at the plurality of terminals.

60. The method of claim 59, wherein at least part of the internet protocol header information is not compressed.

61. The method of claim 59, wherein the compression of the internet protocol header information is performed at a packet data convergence protocol layer.

62. The method of claim 59, wherein the compression of the internet protocol header information is performed at a controlling radio network controller.

63. The method of claim 59, wherein the compressed header data is transmitted to the plurality of users in the point-to-multipoint manner over a wireless path.

64. The method of claim 59, wherein the compression of the internet protocol header information and mapping of the compressed header data to the common physical channel is over a wired path.

65. A method of providing internet protocol header information in a wireless communication system, the method comprising the steps of:

providing internet protocol header information from an internet protocol module to a header compression module associated with one of serving network control and controlling network control;

performing compression of the internet protocol header information in the header compression module to form compressed header data; and

transmitting the compressed header data to at least one terminal of the communication system in one of a point-to-point manner and a point-to-multipoint manner depending upon a threshold value and wherein the compressed header data is provided to a plurality of terminals when the data is transmitted in a point-to-multipoint manner.

66. The method of claim 65, wherein the compressed header data is transmitted in the point-to-point manner if the number of users is below the threshold value.

67. The method of claim 65, wherein the compressed header data is transmitted in the point-to-multipoint manner if the number of users is at or above the threshold value.

68. The method of claim 65, wherein the compression of the internet protocol header information is performed at a packet data convergence protocol layer.

69. The method of claim 65, wherein the transmission of the compressed header data to the at least one terminal comprises a multicast service.

70. The method of claim 69, wherein the multicast service is multimedia broadcast multicast service (MBMS).

71. A wireless communication system for providing internet protocol header information to a plurality of terminals, the wireless communication system comprising:

a header compression module adapted to receive internet protocol header information from an internet protocol module and compress the internet protocol header information to form compressed header data;

a transmitting module adapted to transmit the compressed header data to at least one user of the communication system in one of a point-to-point manner and a point-to-multipoint manner depending upon a threshold value; and

a receiving module adapted to receive and decompress the compressed header data.

72. The wireless communication system of claim 71, wherein the compressed header data is provided to the plurality of terminals when the data is transmitted in a point-to-multipoint manner.

73. The wireless communication system of claim 71, wherein the header compression module is associated with one of serving network control and controlling network control.

74. The wireless communication system of claim 71, wherein the compressed header data is transmitted in the point-to-point manner if the number of terminals is below the threshold value.

75. The wireless communication system of claim 71, wherein the compressed header data is transmitted in the point-to-multipoint manner if the number of terminals is at or above the threshold value.

76. The wireless communication system of claim 71, wherein the header compression module is a packet data convergence protocol (PDCP) entity.

77. The wireless communication system of claim 71, wherein the header compression module is part of a controlling radio network controller (CRNC).

78. A method for providing multicast services as claimed in claim 1 or claim 42 substantially as herein described and illustrated,

79. A method for receiving data as claimed in claim 18 substantially as herein described and illustrated.

80. A radio network controller as claimed in claim 28 substantially as herein described and illustrated.

81. A user equipment as claimed in claim 35 substantially as herein described and illustrated.

82. A method of providing data as claimed in claim 43 substantially as herein described and illustrated.

83. A method of providing Internet protocol header information as claimed in claim 51 or claim 59 or claim 65 substantially as herein described and illustrated.

84. A wireless communication system as claimed in claim 71 substantially as herein described and illustrated.

85. A new method for providing multicast services, a new method for receiving data, a new radio network, a new user equipment, a new method of providing data, a new method of providing Internet protocol header information or a new wireless communication system substantially as herein described.

1/5
FIG. 1

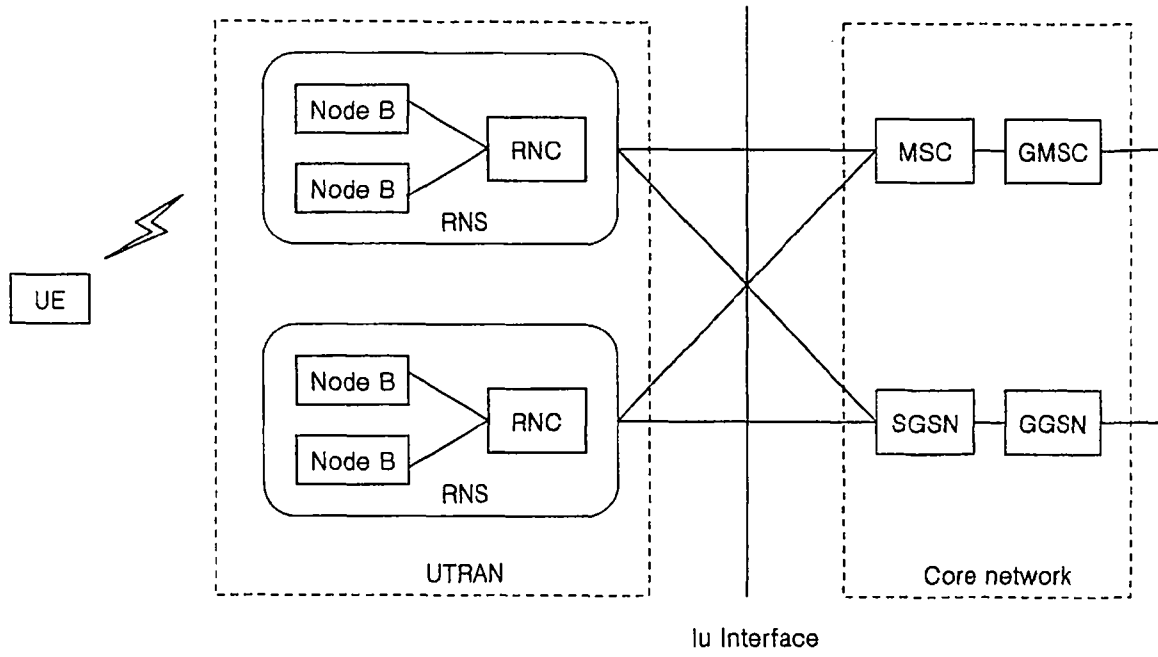

2/5
FIG. 2

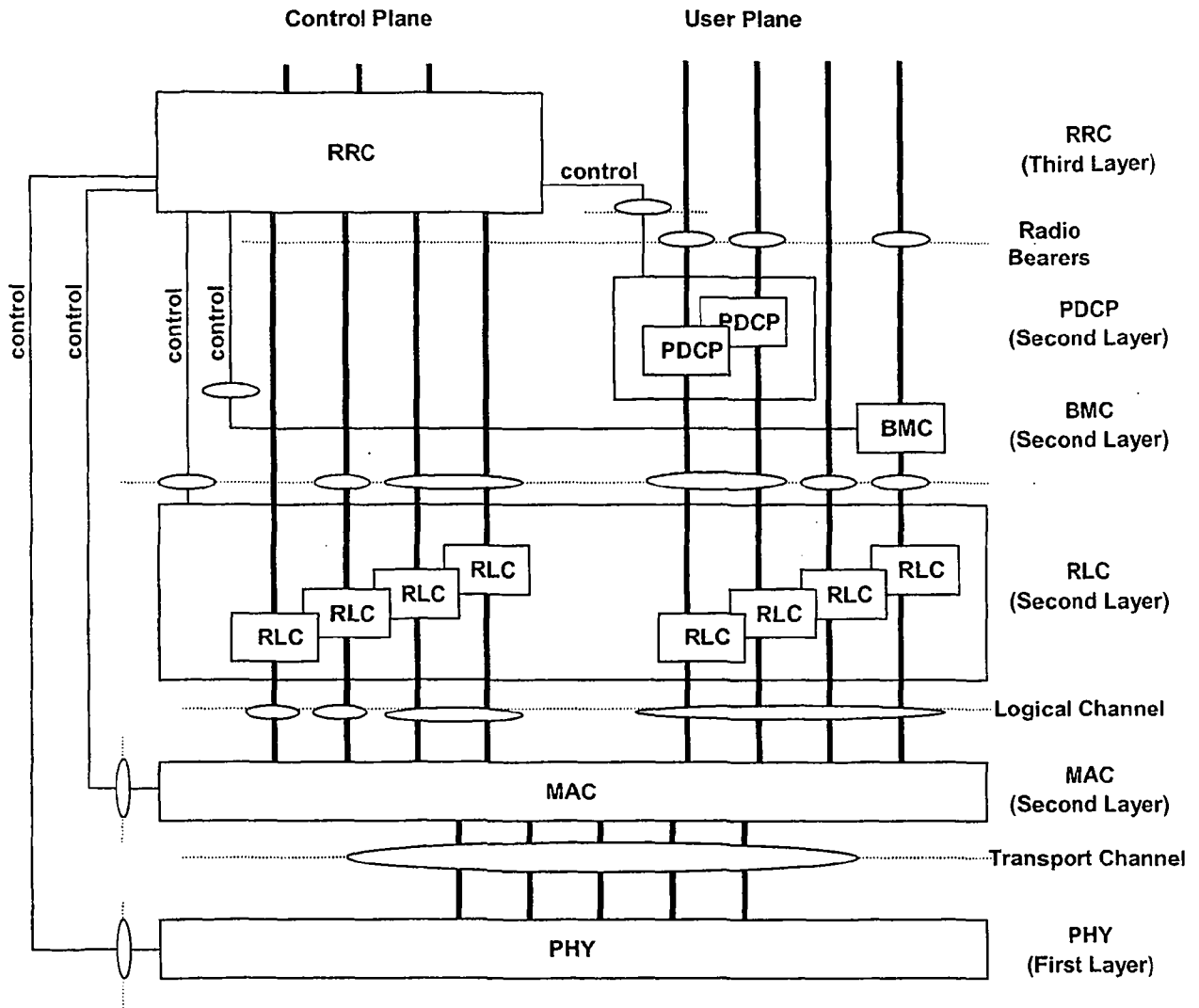

3/5
FIG. 3

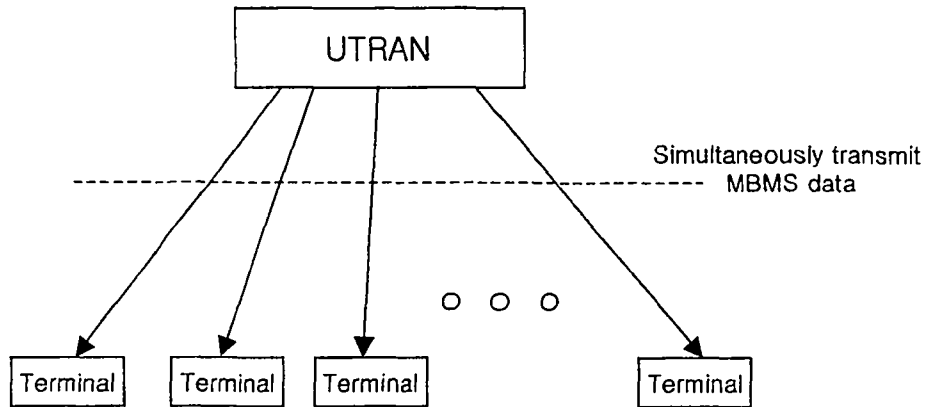
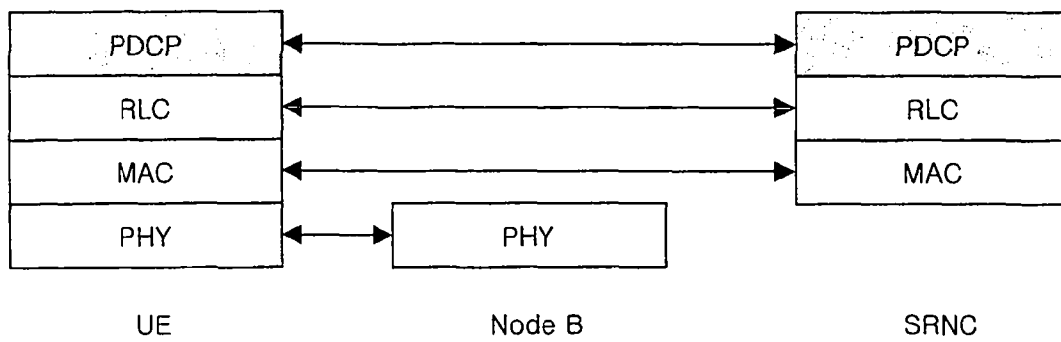
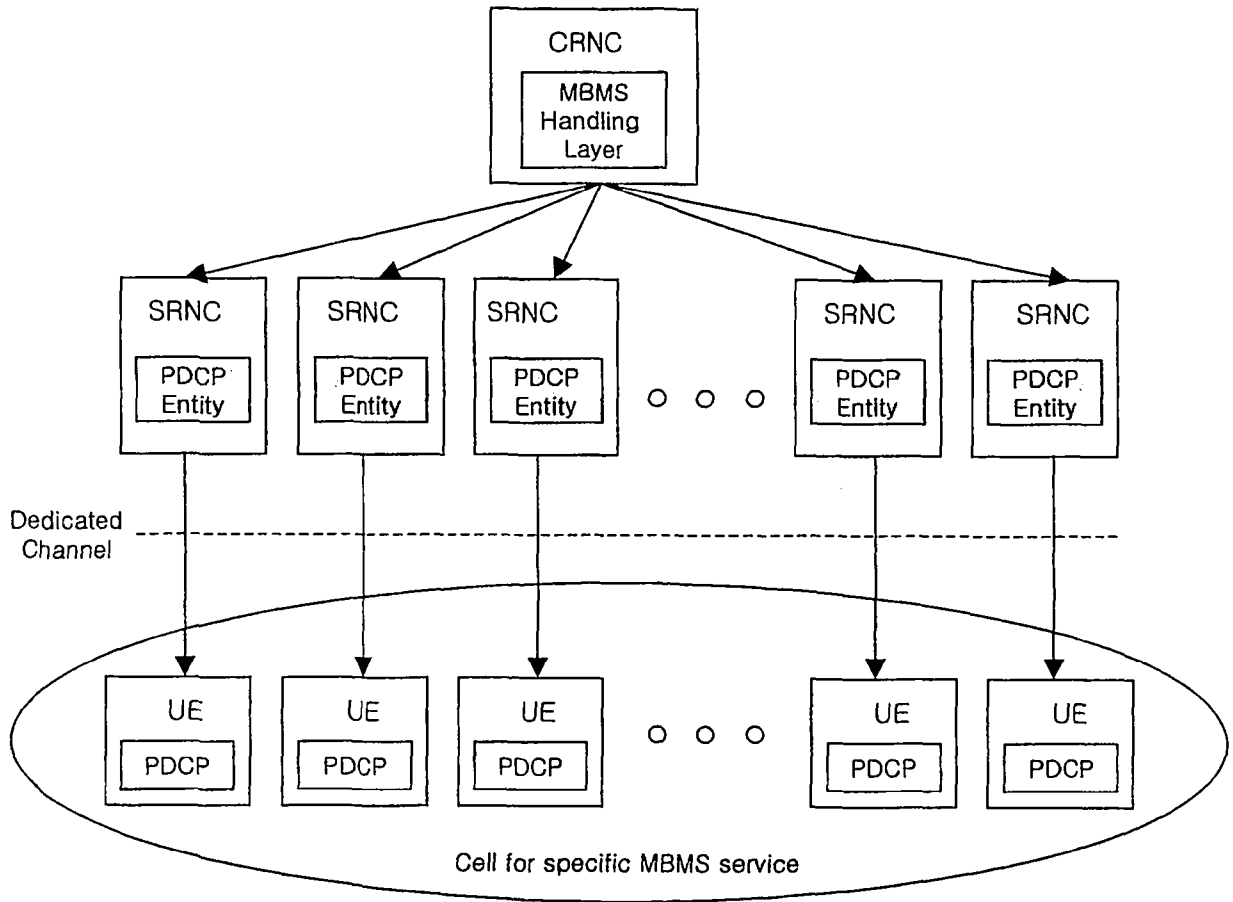

FIG. 4
BACKGROUND ART



4/5
FIG. 5



5/5
FIG. 6

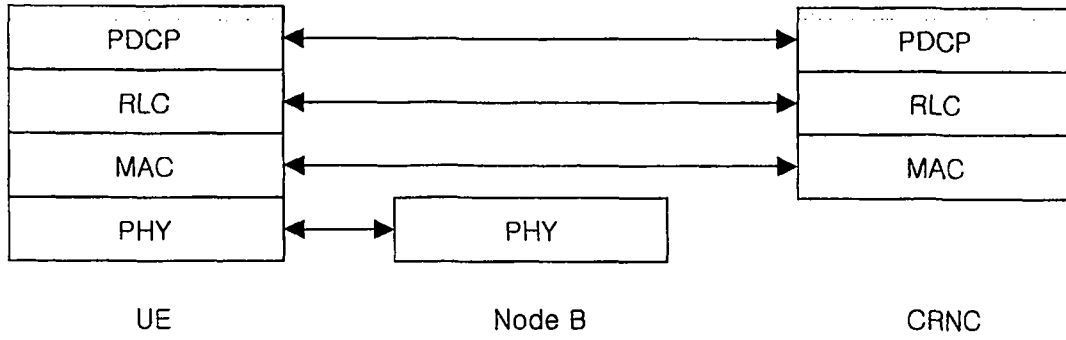

FIG. 7

