

(19)
(12)

(KR)
(A)

(51) 。 Int. Cl.⁷
H01L 21/78

(11)
(43)

10-2004-0064214
2004 07 16

(21) 10-2003-7009249

(22) 2003 07 10

2003 07 10

(86) PCT/JP2002/011941

(87)

WO 2003/049164

(86) 2002 11 15

(87)

2003 06 12

(30) JP-P-2001-00366858 2001 11 30 (JP)

(71) 가 가

가 2 14 3

(72) 가 2 14 3 가 가

가 2 14 3 가 가

가 2 14 3 가 가

가 2 14 3 가 가

(74)

:

(54)

가 (10)

,

,

,

,

.

IC, LS1

가

가

가 100 μm , 50 μm

가

가

가

가

가

가

가

; 가 ;

;

,

가

,

,

,

가

,

가

가 0.5 mm

2.5 mm

가

.

,

,

,

,

.

,

,

가,

,

가

,

,

.

- 1
- 2
- 3
- 4
- 5
- 6
- 7
- 8
- 9
- 10
- 11
- 12
- 13
- 14

가

가

가

가

15
16
17
18
19
20
21

가

가

(C) , 1 (S)
(W1) (C) ,
, 2 (W1) , (W1) (10) (11)
(W1) , 3 ()
(10) , (W1) (11) ,
(10) 63-17981 4-88075

4 , (10) 30 μm (12) ,
가 가
(13) 20 μm (14) 20 μm
(14) (14) (13)
(10) (13)
(14) 가
(W1) (14) (14) (11) , 4 (13)
(13) (14) 가 (14) (14)

(11) , 100 μm , 50 μm PET,
가 O.5 mm 2.5 mm 가 ,
3 (10) (11) (W1) , 5
(20) (20) ()
(20) , (21) (22)가 , (22)
(23) , (23) (24)가 (24)
(25) , (21) (26) 가 (26) 가 ,
(26) (27) 가

(25) , 가 (28) (29)가 ,
(砥石)(31) (30) (30) (28)

(20) (W1) (11) (W1)
(27) (25) , (28)
(25) (28) 가 (30) (31) ,
(31)

(W1) 6 (11) (W1) (11)
7 (40) (11) (W1)

(W1) (40) (41) (11) .
(40) (41) (11)

3) (10) (11) (11) 4 8
(11) (W1) (13) 가 (1) (13)

(14) (10) (11) (11)
(W1) (14)

(10) (11) (W1) 9 (11) (13)
(W1) (14) (10) (11)

(10) (14) (W1) (40) (11) (10)가
가 () . (41)

(W1) (11) ,

(10) (11)
(W1)가 (13) (11)

(40) (41) 가 (W1) , 10
(50)

51) (50) (40) (41) 가 (W1) ()

(53) (41) 가 (W1) , 1 (52) (51) (55)
(54) (54)

(W1)가 (55) (55) +X (56)
가 (S)가 (S)
(57) Y (57) (55)

X (57) Y (55)

90 (57) Y , 11 (S)가 (55)

, (C) ().

가

(11) 가 (W1)

(57) 10 (50) (55) (C)
(60) 12 13 (W2) (S)

2 (11) 14 (W2) (W2) (10)
) 15 (

W2) 5 (20) (27) (11) ((60)
) (25) (W2) 16

(60) (C) (43) (42)
(11) (W2) (10) 17
(13)

(W2) 18 (11) (11) (11)
(10) (10) (W2) (13) (40)

(10) (14) (W2) (11) (10)
가 () (40) (41)

(W2) (11)

(W2)

(10) (13) (11)
(W2)가

1) (11) (10) (C) (11) (C) 19 (W2) (1
(41) () (C) (40)

(W1, W2)
(W1, W2)

(C)

20 (11a) (11a) (W1 W2) 5 (W1 W2) (20) (2

7) (W1, W2) (71) (11a) (70) (70) (71) (11a) (W1, W2) (W1, W2) (72) (W1, W2) (W1, W2) (W1, W2) (51) (11) 가 (51) 1 m m 2 mm

가

(57)

1.

;

가

;

가

;

가

2.

1

가

3.

1

3 4. ,

4 5. ,
가

5 6. ,
가 , 가 0.5 mm 2.5 mm

7. , ;
 ;
가 ;
가 ;

7 8. ,
가

7 9. ,

9 10. ,

10 11.

,

가

.

11 12.

,

가

,

가 0.5 mm

2.5 mm

.

13.

,

;

;

가

;

,

13 14.

,

가

,

13 15.

,

15 16.

,

16 17.

,

가

.

17 18.

,

가

,

가 0.5 mm

2.5 mm

.

1

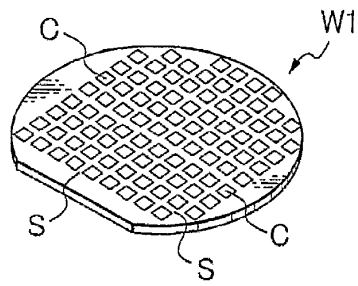

2

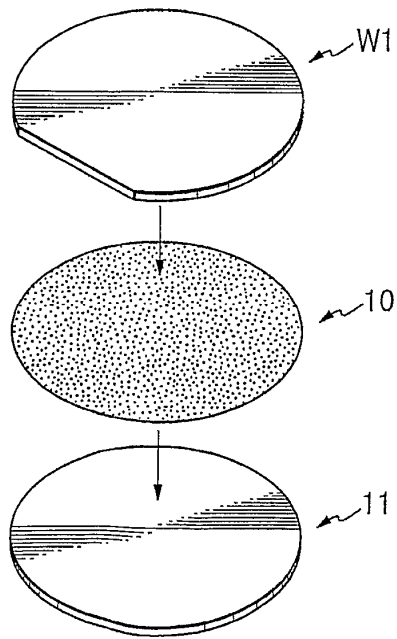

3

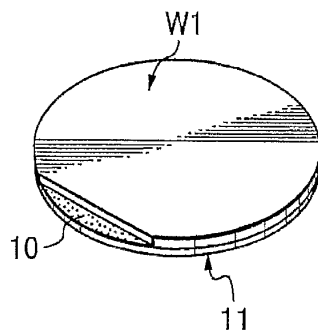

4

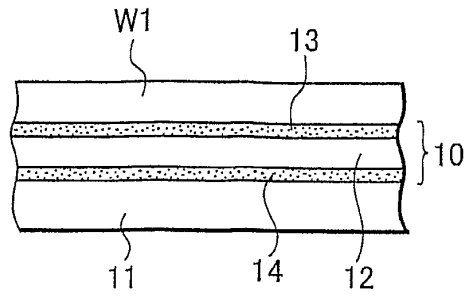

5

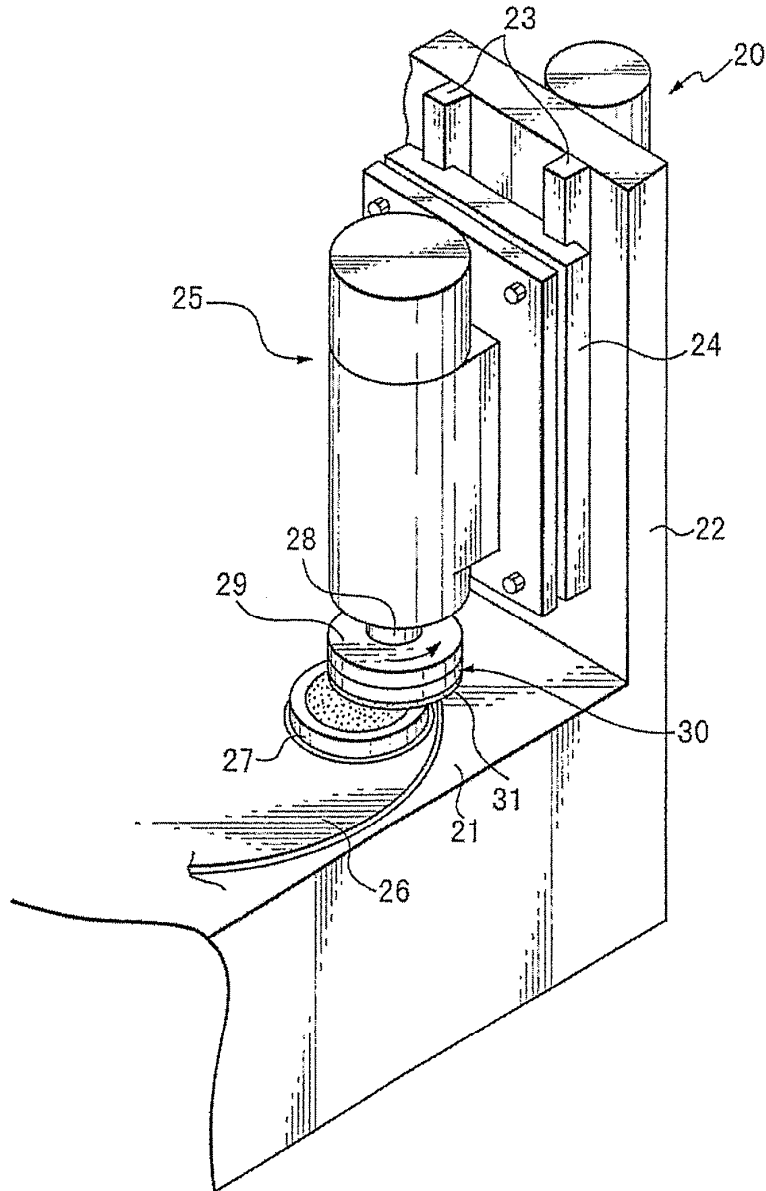

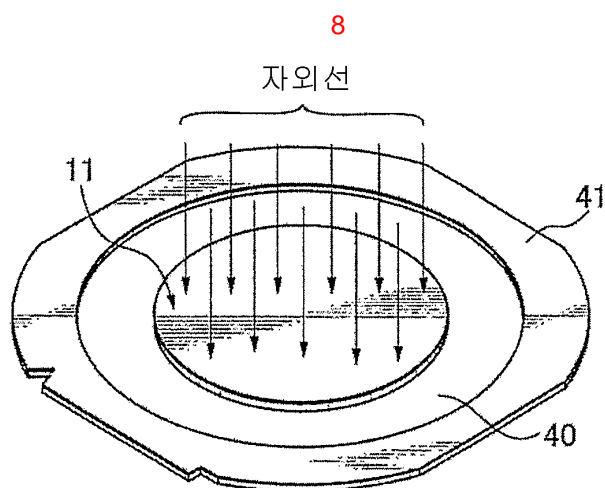
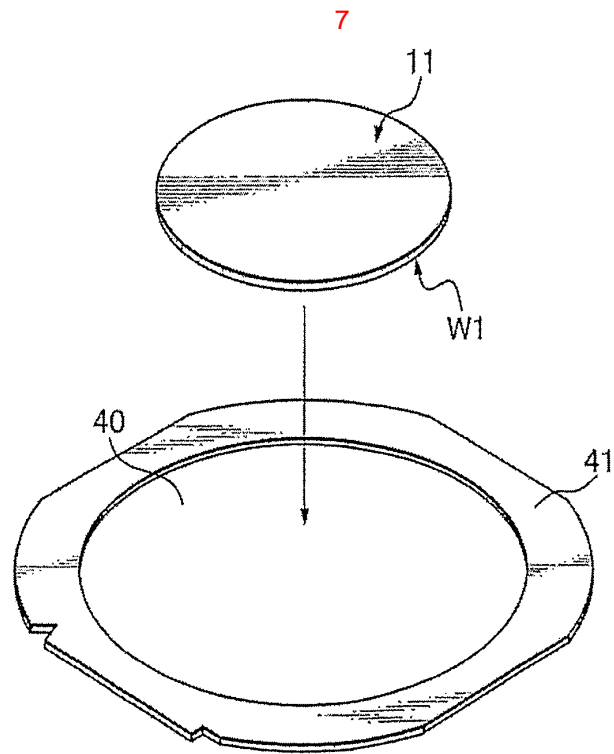
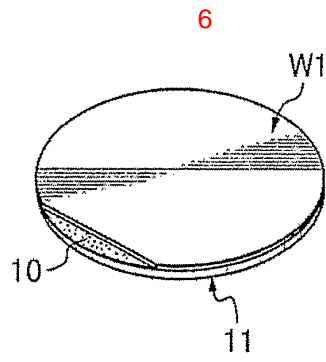

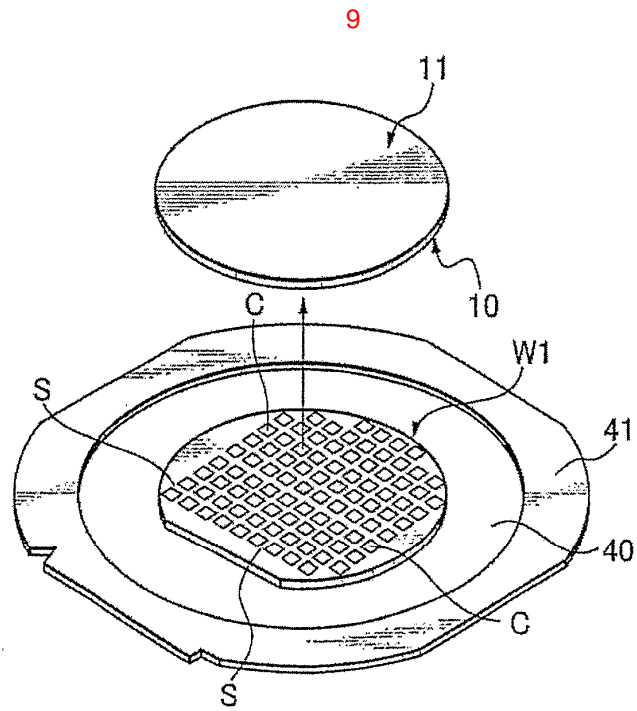

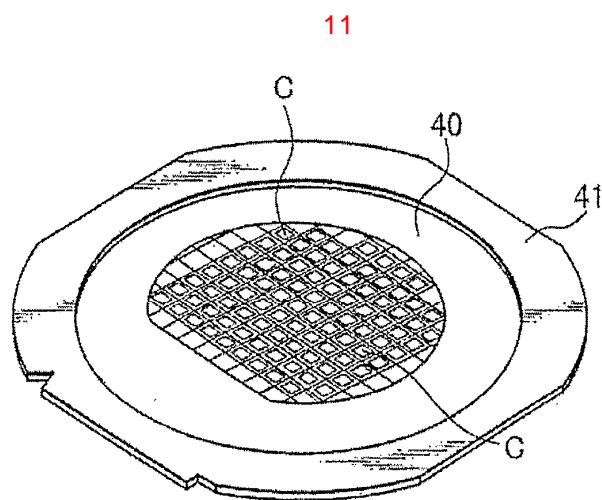
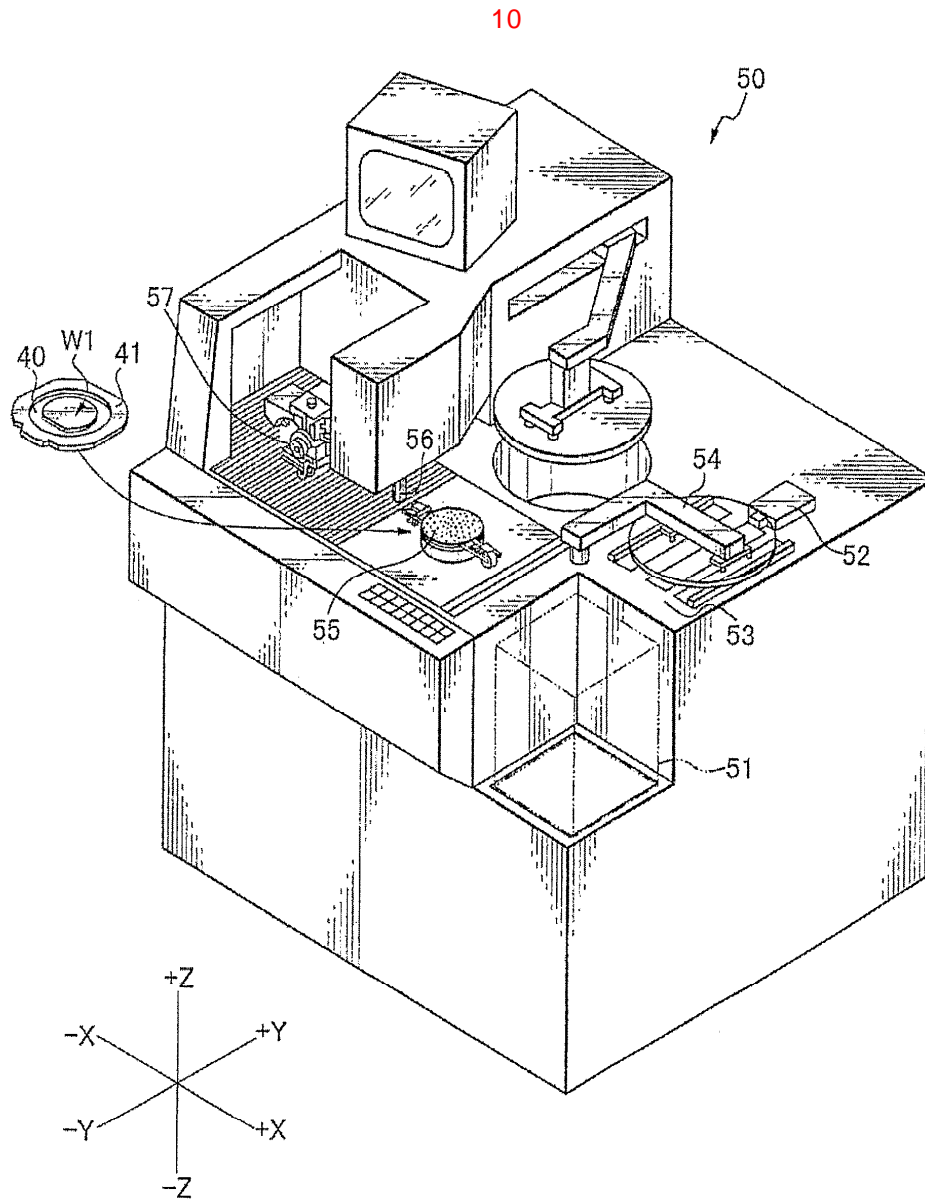

12

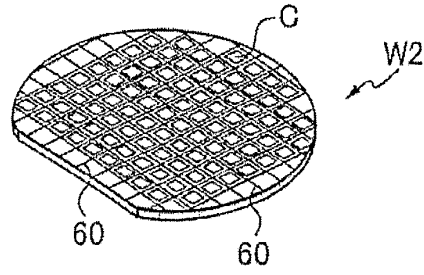

13



14

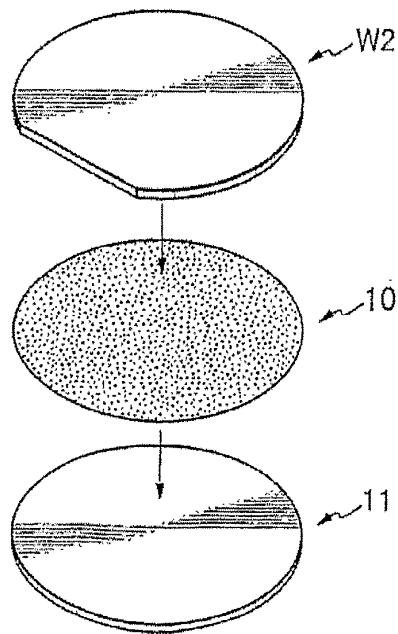

15

