



(11)

EP 3 064 664 A1

(12) **EUROPEAN PATENT APPLICATION**

(43) Date of publication:
07.09.2016 Bulletin 2016/36

(51) Int Cl.:
E03D 5/10 (2006.01) E03D 1/14 (2006.01)

(21) Application number: **16398002.2**

(22) Date of filing: **07.03.2016**

(84) Designated Contracting States:
AL AT BE BG CH CY CZ DE DK EE ES FI FR GB GR HR HU IE IS IT LI LT LU LV MC MK MT NL NO PL PT RO RS SE SI SK SM TR
Designated Extension States:
BA ME
Designated Validation States:
MA MD

(72) Inventors:
• **Moura de Oliveira, António Manuel**
3800-250 Aveiro (PT)
• **Gonçalves de Matos, Bruno Guilherme**
4460-679 Vila Nova de Famalicão (PT)
• **Pinto Lopes, Jaime Rafael**
4460-080 Guifões (PT)
• **Gonçalves da Costa Pereira, Pedro Miguel**
4900-932 Santa Maria Maior, Viana do Castelo (PT)

(30) Priority: **06.03.2015 IT MI20150344**

(71) Applicant: **Oliveira & Irmão S.A.**
3800 Aveiro (PT)

(74) Representative: **Cernuzzi, Daniele et al**
Studio Torta S.p.A.
Via Viotti, 9
10121 Torino (IT)

(54) **AUTOMATIC SYSTEM AND METHOD FOR FLUSHING A SANITARY BOWL**

(57) An automatic system (1) for flushing a sanitary bowl (2) comprises: a flushing valve (5) connectable to a water supply tube (3) of the sanitary bowl (2) and capable of operating in at least two flushing modes in which two different amounts of water are flushed; a flushing control device (6) acting on the flushing valve (5) and comprising a control unit (11) connected to the flushing valve (5) for selectively actuating a first or a second flushing mode; and an acoustic sensor (13) connected to the control unit (11); the control unit (11) is configured to actuate one or the other flushing mode depending on whether the acoustic sensor (13) detects a first or a second type of noise.

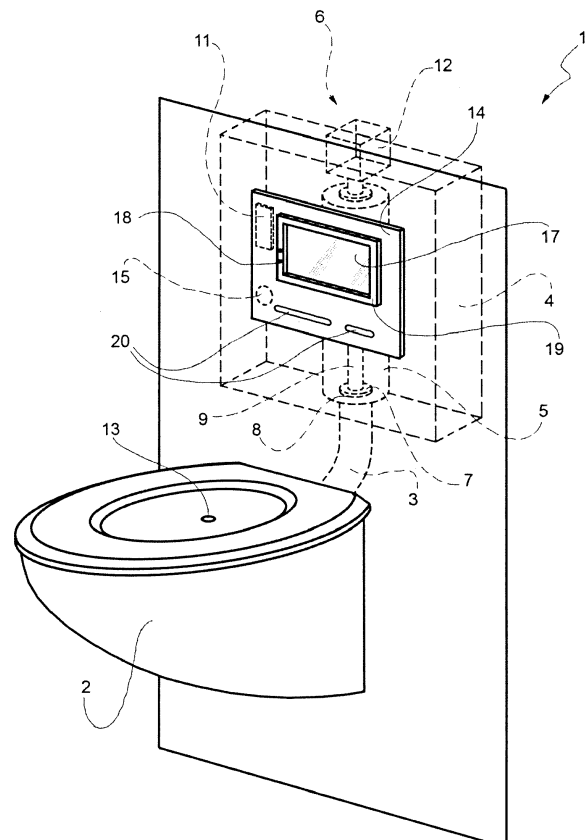

EP 3 064 664 A1

Description

[0001] The present invention relates to an automatic system and a method for flushing a sanitary bowl.

[0002] It is known to use automatic systems in order to avoid the user having to manually control, pressing buttons or levers, the flushing of a sanitary bowl, for example using the water contained in a cistern.

[0003] Essentially, an automatic flushing system of a sanitary bowl includes a sensor, such as a contact or presence sensor, and an electronic control board connected to the sensor; based on the signals received from the sensor, the electronic board controls the turning on and off of a water supply tap or, if a cistern is used, it activates a cistern flush valve actuator.

[0004] The known automatic systems generally have the drawback of flushing a single predefined quantity of water, and do not allow the selection of the amount of water to be flushed as needed, namely depending on the functions performed by the user.

[0005] Saving water is instead an increasingly felt need, as is that of using dual-flush flushing valves, able to selectively flush two different amounts of water: the user can decide whether to actuate the complete flush or partial flush as needed, i.e. depending on the physiological functions performed.

[0006] One purpose of the present invention is thus to provide an automatic method and system of flushing a sanitary bowl which overcome the drawbacks mentioned above of the prior art. In particular, one purpose of the invention is to provide a system and a method permitting the automatic actuation of flushing in two flushing modes, selected according to the functions performed by the user.

[0007] The present invention thus relates to an automatic flushing system of a sanitary bowl and a method of flushing a sanitary bowl as defined in essential terms in the appended claims 1 and 13, respectively, as well as, for the additional preferred characteristics, in the dependent claims.

[0008] The invention permits the actuation of flushing of the sanitary bowl in a fully automatic manner without requiring the intervention of the user, and according to two different flushing modes (for example, complete flush and partial flush) selected, again automatically, as appropriate.

[0009] The system of the invention automatically recognizes the type of physiological function performed by the user and selects the appropriate flushing mode (complete or partial) as a result.

[0010] Further features and advantages of the present invention will be evident from the description below, of a non-limiting example of implementation with reference to the appended drawing which is a perspective schematic view of an automatic flushing system of a sanitary bowl according to the invention.

[0011] In the appended drawing, reference numeral 1 globally denotes an automatic flushing system of a san-

itary bowl 2.

[0012] In the non-limiting example shown (but not necessarily), the bowl 2 is connected by a water supply tube 3 to a cistern 4, for example of the flush mounted type (i.e. recessed in use in a wall).

[0013] The system 1 comprises a flushing valve 5, placed in the cistern 4 and connected to the tube 3 so as to act on the tube 3, in particular to open/close a through hole between the cistern 4 and the tube 3; and a flushing control device 6, acting on the flushing valve 5 to open/close the flushing valve 5.

[0014] The cistern 4 and the flushing valve 5 may be of the known type and are therefore not shown in detail for the sake of simplicity.

[0015] In general, the flushing valve 5 has a mobile obturator 7 acting in conjunction with a flushing hole 8 of the cistern 4; for example, the obturator 7 is placed at a lower end of an overflow pipe 9 of the cistern 4.

[0016] The flushing valve 5 is designed to operate alternately according to two different flushing modes in which two different quantities of water are flushed: in particular, the flushing valve 5 is a dual-flush flushing valve able to selectively actuate a complete flush and a partial flush of the water contained in the cistern 4.

[0017] The device 6 comprises a control unit 11, an actuator 12, controlled by the control unit 11 and acting on the flushing valve 5 and precisely on the obturator 7, and an acoustic sensor 13 connected to the control unit 11.

[0018] The control unit 11 is for example an electronic board (known), supported for example (but not necessarily) by a control plate 14 of the wall-mounted type in front of the cistern 4 closing an inspection opening of the cistern 4.

[0019] The actuator 12 is for example an electromechanical actuator connected to the obturator 7 to move the obturator 7 and thus open/close the flush hole 8 and thus the flushing, valve 5 (and thereby actuate one or other flushing modes).

[0020] The acoustic sensor 13 is for example a microphone and can be positioned in the bowl 2, especially on a side wall of the bowl 2, or near the bowl 2 or in another position in the room where the bowl 2 is situated, for example on the control plate 14, inside the cistern 4, in particular inside the overflow pipe 9, etc.

[0021] The acoustic sensor 13 may be equipped with a support or attachment member to attach the acoustic sensor 13 in the desired position on the bowl 2 or other support surface.

[0022] The acoustic sensor 13 is connected to the control unit 11 to send signals to the control unit 11. For the sake of simplicity the drawing does not show the connections between the control unit 11 and the acoustic sensor 13, nor generally between the various components of the system 1, nor the electrical connections for the power supply of the components of the system 1. It is however understood that the components of the system 1, in particular the control unit 11 and the acoustic sensor 13,

may be connected in any known way with or without wires, for example in any wireless type connection, such as Bluetooth etc.

[0023] As will be described in more detail below, the control unit 11 is configured to actuate one or other flushing mode of the flushing valve 5 (i.e. complete or partial flushing of the water in the cistern 4) depending on whether the acoustic sensor 13 detects a first or a second type of noise.

[0024] The system 1 also comprises a proximity sensor 15, for example a microwave sensor, able to detect the presence of a user at a predefined distance from the proximity sensor 15 and connected (wired or any wireless type connection such as Bluetooth etc.) to the control unit 11.

[0025] For example, the proximity sensor 15 is placed on the control plate 14.

[0026] The control unit 11 also controls a display 17 and a plurality of LEDs 18, for example also placed on the control plate 14 (only two LEDs 18 are shown, by way of example, in the drawing).

[0027] The display 17 provides the user with operating information about the system 1, in particular the water consumption; and/or any other type of information or message, by means of images, photographs, graphics, captions, drawings etc.

[0028] The LEDs 18 can switch on, controlled by the control unit 11, in different light patterns in order to provide different lighted messages.

[0029] For example, the LEDs 18 are arranged around the display 17 to form a closed loop frame 19.

[0030] Preferably, the LEDs 18 are able to provide light of different colours.

[0031] The system 1 comprises then, preferably, also a pair of manual commands 20 to actuate the flushing valve 5 in the respective flushing modes in case of malfunction of the automatic system 1.

[0032] For example, the commands 20 comprise a pair of capacity sensors, placed for example on the control plate 14, which command, again through the control unit 11, the actuator 12.

[0033] The system 1 works, in implementation of the flushing method according to the invention, as follows.

[0034] When a user approaches the system 1 and thus the bowl 2, the proximity sensor 15 detects the presence of the user and sends a presence signal to the control unit 11.

[0035] The control unit 11 activates the acoustic sensor 13 which starts to detect noises.

[0036] At the same time, the control unit 11 may also command the LEDs 18 to switch on in one colour or according to established patterns.

[0037] The acoustic sensor 13 detects the noise generated by the user in performing the physiological functions, namely the noise generated by contact of the faeces or urine with the water in the bowl 2 and/or the walls of the bowl 2.

[0038] The acoustic sensor 13 sends a corresponding

signal, representative of the noise detected, to the control unit 11.

[0039] The control unit 11 processes the signals representative of the noise received from the acoustic sensor 13 and discriminates the signals received from the acoustic sensor 13 into a first and a second type of noise by comparing the signals received with sample signals stored in the control unit 11.

[0040] In particular, the control unit 11 contains programmes to analyse the fundamental frequencies of the signals received from the acoustic sensor 13 and compare the fundamental frequencies identified with sample frequencies stored.

[0041] The control unit 11 thus recognises if the noise detected by the acoustic sensor 13 is associated with the expulsion of faeces or urine.

[0042] After a set time or after receiving from the proximity sensor 15 a signal of absence signalling the user's departure, the control unit orders the intervention of the actuator 12 on the flushing valve 5 to actuate one or other flushing mode (i.e. complete or partial flush) depending on the type of noise detected.

[0043] The control unit 11 also controls the switching on of the display 17 and of the LEDs 18 to provide information and messages to the user.

[0044] For example, the control unit 11 shows on the display 17 water consumption information, or other operating information on the system 1, and switches on the LEDs 18 to selectively provide a first or a second light message corresponding to the flushing mode actuated.

[0045] For example, the control unit 11 switches on the LEDs 18 all along the frame 19 if a complete flush has been actuated, and only some of the LEDs 18, for instance along only one half of the frame 19, if partial flushing has been actuated.

[0046] Lastly, it is understood that further modifications and variations may be made to the automatic system and method for flushing a sanitary bowl described and illustrated while remaining within the scope of the appended claims.

Claims

1. An automatic system (1) for flushing a sanitary bowl (2), comprising a flushing valve (5) connectable to a water supply tube (3) of the sanitary bowl (2) and capable to operate in at least two flushing modes in which respective different amounts of water are discharged; and a flushing control device (6), acting on the flushing valve (5) and comprising a control unit (11) connected to the flushing valve (5) for selectively actuating a first and a second flushing mode; the system (1) being **characterized by** comprising an acoustic sensor (13) connected to the control unit (11); and in that the control unit (11) is configured to actuate one or the other flushing mode depending on whether the acoustic sensor (13) detects a first

- or a second type of noise.
2. A system according to claim 1, wherein the control unit (11) is configured to process signals representative of the noise received from the acoustic sensor (13) and discriminate the signals received from the acoustic sensor (13) in a first and a second type of noise. 5
 3. A system according to claim 2, wherein the control unit (11) is configured to discriminate the signals received from the acoustic sensor (13) in a first and a second type of noise by comparing the signals received from the acoustic sensor (13) with sample signals stored in the control unit (11). 10
 4. A system according to one of the preceding claims, comprising a proximity sensor (15) capable of detecting the presence of a user at a predetermined distance from the proximity sensor (15) and connected to the control unit (11); the control unit (11) being configured so as to activate the acoustic sensor (13) after receiving from the proximity sensor (15) a presence signal revealing the presence of a user. 15
 5. A system according to claim 4, wherein the control unit (11) is configured so as to control the flushing valve (5) for actuating one or the other flushing mode after receiving from the proximity sensor (15) an absence signal revealing the user's departure. 20
 6. A system according to one of the preceding claims, comprising a plurality of LEDs (18) capable of switching on according to different light patterns and connected to the control unit (11), the control unit (11) being configured so as to control the switching on of the LEDs (18) to selectively provide a first or a second light pattern corresponding to the flushing mode actuated. 25
 7. A system according to claim 6, wherein the LEDs (18) are capable of providing light of different colors. 30
 8. A system according to one of the preceding claims, comprising a display (17) connected to the control unit (11) for providing the user with operating information about the system (1). 35
 9. A system according to one of the preceding claims, comprising manual controls (20) for actuating the flushing valve (5) in the respective flushing modes. 40
 10. A system according to claim 9, wherein the manual controls (20) comprise a pair of capacity sensors. 45
 11. A system according to one of the preceding claims, comprising an electromechanical actuator (12) operated by the control unit (11) and acting on the flushing valve (5) for actuating one or the other flushing mode. 50
 12. A system according to one of the preceding claims, wherein the flushing valve (5) is a dual-flush flushing valve installable in a flushing tank (4) for selectively actuating either a complete or a partial flushing of the water contained in the flushing tank (4). 55
 13. A method for flushing a sanitary bowl (2), comprising the steps of: detecting by means of an acoustic sensor (13) a noise made by a user in carrying out physiological functions in the sanitary bowl (2); and actuating a first or a second flushing mode, in which respective different amounts of water are discharged in the sanitary bowl (2), depending on whether a first or a second type of noise is detected.
 14. A method according to claim 13, comprising the step of processing signals representative of the noise received from the acoustic sensor (13) and discriminating the signals received from the acoustic sensor (13) in a first and a second type of noise.
 15. A method according to claim 14, comprising the step of discriminating the signals received from the acoustic sensor (13) in a first and a second type of noise by comparing the signals received from the acoustic sensor (13) with stored sample signals.
 16. A method according to one of claims 13 to 15, comprising the steps of: detecting the presence of a user by means of a proximity sensor (15) and activating the acoustic sensor (13) after the proximity sensor (15) has detected the presence of the user.
 17. A method according to claim 16, wherein one or the other flushing mode is actuated after the proximity sensor (15) detects the user's departure.
 18. A method according to one of claims 13 to 17, comprising a step of switching on LEDs (18) according to different light patterns for selectively providing a first or a second light pattern corresponding to the flushing mode actuated.

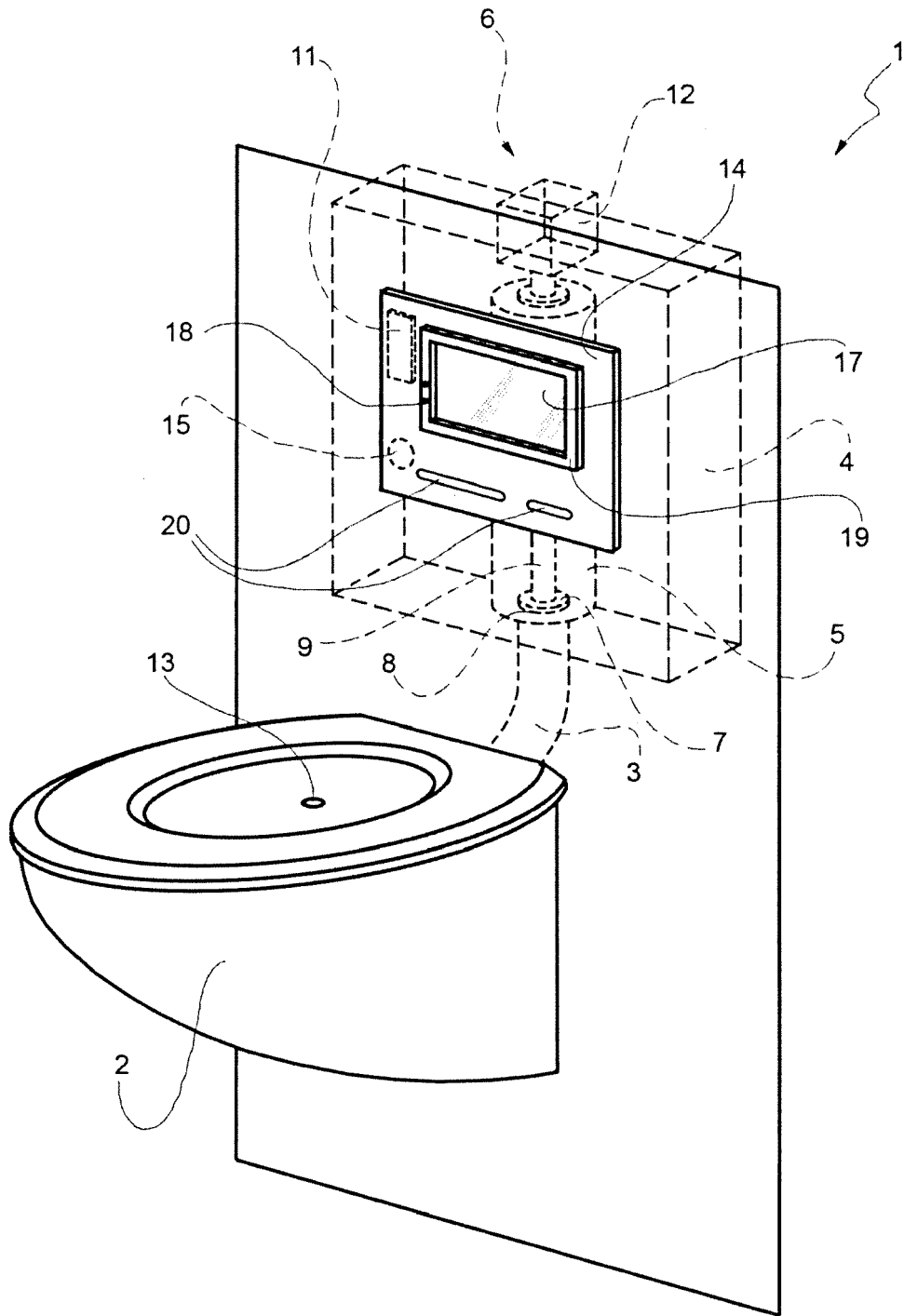



EUROPEAN SEARCH REPORT

Application Number
EP 16 39 8002

5

10

15

20

25

30

35

40

45

50

55

DOCUMENTS CONSIDERED TO BE RELEVANT			
Category	Citation of document with indication, where appropriate, of relevant passages	Relevant to claim	CLASSIFICATION OF THE APPLICATION (IPC)
X A	WO 2009/124866 A1 (LANG EDO [CH]; OBRIST ROLAND [CH]) 15 October 2009 (2009-10-15) * page 3, line 22 - page 14, line 9; figures 1, 2A, 2B * -----	1-5,9-17 6	INV. E03D5/10 E03D1/14
X	DE 299 18 335 U1 (KERAMAG KERAMISCHE WERKE AG [DE]) 30 December 1999 (1999-12-30) * the whole document * -----	1-4, 11-16	
A	WO 98/07930 A1 (CWS AG [CH]; EHRENSPERGER MARKUS [CH]; MEIER HANS PETER [CH]) 26 February 1998 (1998-02-26) * page 5, line 1 - page 8, line 32; figure 4 * -----	1,6,7, 13,18	
			TECHNICAL FIELDS SEARCHED (IPC)
			E03D
The present search report has been drawn up for all claims			
Place of search Munich		Date of completion of the search 27 June 2016	Examiner Fajarnés Jessen, A
CATEGORY OF CITED DOCUMENTS X : particularly relevant if taken alone Y : particularly relevant if combined with another document of the same category A : technological background O : non-written disclosure P : intermediate document		T : theory or principle underlying the invention E : earlier patent document, but published on, or after the filing date D : document cited in the application L : document cited for other reasons & : member of the same patent family, corresponding document	

EPO FORM 1503 03/02 (P04/C01)

ANNEX TO THE EUROPEAN SEARCH REPORT
ON EUROPEAN PATENT APPLICATION NO.

EP 16 39 8002

5

This annex lists the patent family members relating to the patent documents cited in the above-mentioned European search report. The members are as contained in the European Patent Office EDP file on The European Patent Office is in no way liable for these particulars which are merely given for the purpose of information.

27-06-2016

10

Patent document cited in search report	Publication date	Patent family member(s)	Publication date
WO 2009124866 A1	15-10-2009	EP 2288762 A1 WO 2009124866 A1	02-03-2011 15-10-2009

DE 29918335 U1	30-12-1999	NONE	

WO 9807930 A1	26-02-1998	AT 199955 T AU 6654296 A CA 2262747 A1 DE 59606650 D1 DK 0918908 T3 EP 0918908 A1 ES 2156999 T3 HU 9903390 A2 JP 3787163 B2 JP 2001505267 A NO 990698 A PL 331629 A1 PT 918908 E SK 18599 A3 US 6098211 A WO 9807930 A1	15-04-2001 06-03-1998 26-02-1998 26-04-2001 23-04-2001 02-06-1999 01-08-2001 28-02-2000 21-06-2006 17-04-2001 15-02-1999 02-08-1999 29-06-2001 10-09-1999 08-08-2000 26-02-1998

15

20

25

30

35

40

45

50

55

EPO FORM P0459

For more details about this annex : see Official Journal of the European Patent Office, No. 12/82