

[72] Inventor **Bert Phillips**
 215 Wilpot Drive, State College, Pa. 16801
 [21] Appl. No. **739,088**
 [22] Filed **June 21, 1968**
 [45] Patented **Mar. 16, 1971**

2,913,695	11/1959	Borghult et al.	13/25(X)
3,083,445	4/1963	Hill.....	13/25(X)
3,195,093	7/1965	Dillon.....	338/238
3,267,733	8/1966	Chambers	338/238(X)
3,369,209	2/1968	Edwin et al.	338/238

Primary Examiner—H. B. Gilson
Attorneys—Rupert J. Brady and Thomas E. Sterling

[54] **PROTECTION OF OXIDIZABLE ELECTRIC FURNACE ELEMENTS AT HIGH TEMPERATURES**
 8 Claims, 5 Drawing Figs.

[52] U.S. Cl. **13/25,**
 338/238
 [51] Int. Cl. **H05b 3/62,**
 H01c 1/02
 [50] Field of Search 13/25, 25
 (X); 338/238—242

ABSTRACT: Electrical furnace heating elements and structural components are confined within closed or limited access volumes against oxidation by establishing and maintaining a low partial pressure of oxygen in the volume containing the oxidizable element or component. This is effected by including in the volume with the element an oxygen-buffering material, such as a carbonaceous material, which buffering material is potentially reactive with oxygen to react with oxygen at elevated temperatures to establish a reducing atmosphere about such elements, the carbonaceous materials being available to react with any oxygen in the confined volume.

[56] **References Cited**
 UNITED STATES PATENTS
 1,763,117 6/1930 Woodson 338/242(UX)
 2,701,410 2/1955 Huck et al. 338/242(X)

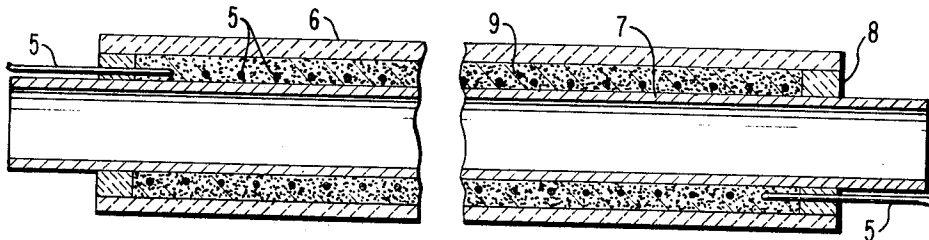

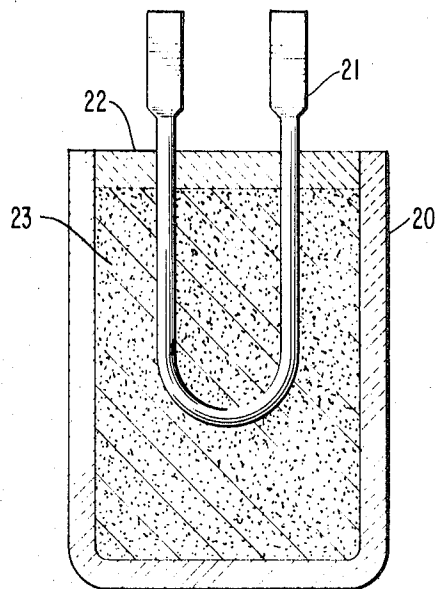
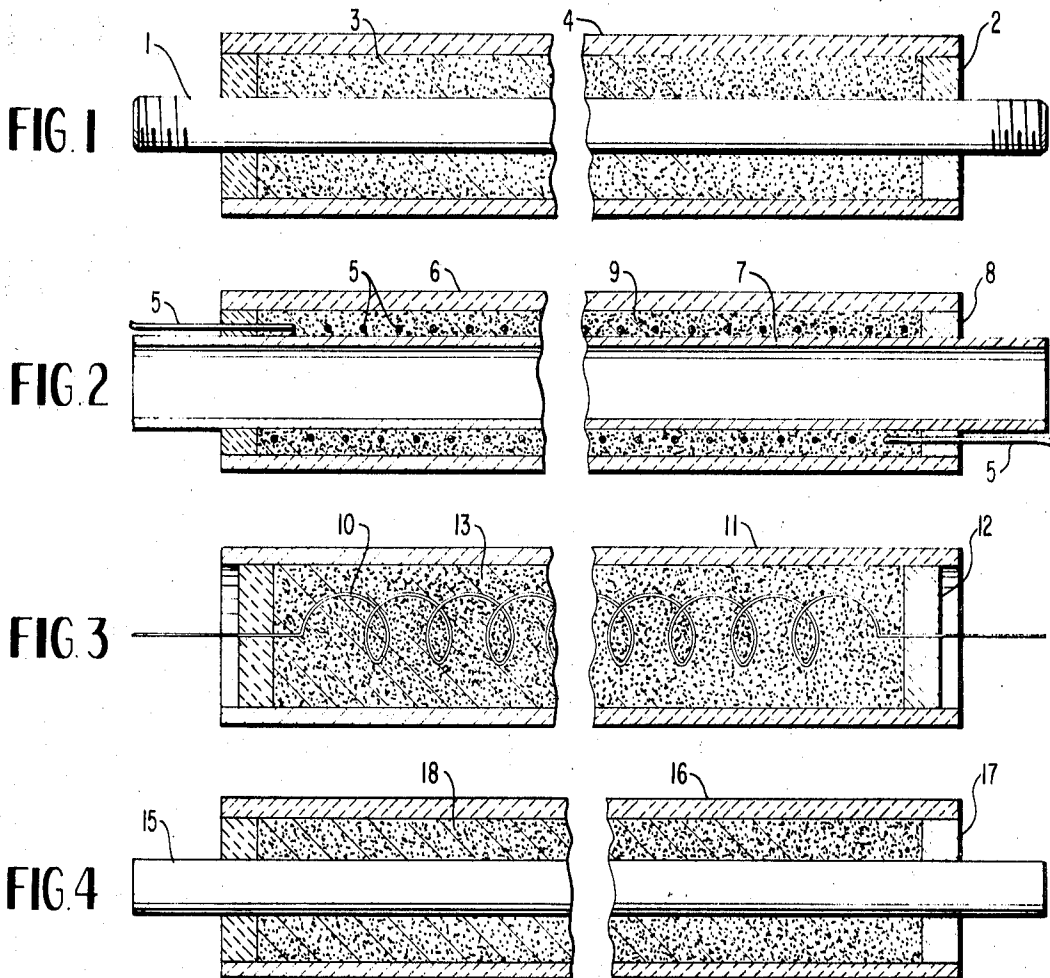

FIG 5

INVENTOR
BERT PHILLIPS
BY *Robert J. Brady*
and *Thomas E. Sterling*
ATTORNEYS

PROTECTION OF OXIDIZABLE ELECTRIC FURNACE ELEMENTS AT HIGH TEMPERATURES

FIELD OF THE INVENTION

The invention pertains to the protection against oxidation of metals, of alloys and of compounds of elements of groups 3, 4 and 5 of the Periodic Table which are employed at high temperatures. Many such high temperature materials are not resistant to oxidation at high temperatures, which oxidation seriously limits the effective life in an oxidizing environment. The invention invokes a novel concept for prolonging the effective life of such materials by establishing and maintaining in the region about such elements a protective zone of low partial pressure of oxygen by a reaction which diminishes the oxygen concentration of air that normally might contact the material. This is effected by including in the space adjacent the element a compound or material which is more reactive with oxygen at elevated temperatures, and preferably a material such as carbon, carbonaceous material or carbon-forming material which can react with oxygen to produce a reducing atmosphere of high CO to CO₂ ratio fixed by the presence of carbon.

DESCRIPTION OF THE PRIOR ART

The problem of limiting or preventing oxidation of oxidizable materials at high temperatures has been long standing and many methods of providing protection have been attempted but none of these has been particularly successful. These suggestions include the development of films or coatings on the element to provide an oxygen diffusion barrier, encasing in ceramic or other thermal resistant shields or otherwise enclosing the elements to be protected.

SUMMARY

The salient object of the invention is to provide lasting high temperature performance of oxidizable metals, of alloys or of compounds of elements of groups 3, 4 and 5 by enclosing them in a sealed or limited access volume and including in that volume some carbon, carbon-containing or carbon-producing, or other oxygen pressure-buffering material which is effective in maintaining a very low partial pressure of oxygen within the confined volume until the buffer has been completely transformed or transported by chemical oxidation. In practice, oxygen is always made available through leaks, channels, and pores in the enclosing shield which develop in time, as well as by atomic diffusion through the crystal lattice. A purpose of the invention is, as noted, to provide a material which consumes this oxygen as it is made available, thereby preventing completely the oxidation of the structural or heating material for a period of time that the oxygen pressure buffer material remains active.

Another objective of the invention is to provide oxidation protection for materials in use at temperatures approaching their melting points by a buffering system, based on C-CO-CO₂ equilibrium, which is effective up to temperatures approximating 6000° F. Through the effective partial pressure of oxygen established by this equilibrium increases with increasing temperature. It is, nevertheless, still very effective because the carbon in the protective zone becomes increasingly reactive to oxygen with increased temperature, and metals normally become decreasingly reactive to oxygen with increased temperature, particularly at the working temperatures contemplated by this invention, i.e. above about 1300° F.

An additional object of the invention is to provide a long-lasting protective system for refractory metals, for alloys and for compounds of elements of groups 3, 4 and 5 used as structural materials by enclosing such materials within a chamber and placing within such chamber an oxygen-buffering material or mixture of materials.

Another object of the invention is to provide a long-lasting protective system for refractory metals, for alloys and for compounds of elements of groups 3, 4 and 5 when used as furnace elements by enclosing such elements in a chamber pro-

vided with an oxygen-buffering material or mixture of materials of the character described.

These and other related objects will be understood from a consideration of the specification and drawings.

IN THE DRAWINGS

FIG. 1 is a longitudinal sectional view showing a structural member protected in accordance with the invention, which member and parts thereof may be of any chosen size and shape;

FIG. 2 is a longitudinal sectional view showing an electrical resistance wire element in a tube-furnace design which is protected in accordance with the principles of the invention;

FIG. 3 is a longitudinal sectional view depicting an electrical resistance wire element in a rod-heater design provided with a protective zone in accordance with the invention;

FIG. 4 is a longitudinal sectional view illustrating an electrical resistance carbide-type heating element provided with protective material according to the principles of the invention; and

FIG. 5 is a longitudinal sectional view showing an electrical resistance silicide-type heating element protected according to the principles of the invention.

DESCRIPTION OF PREFERRED EMBODIMENTS

In FIG. 1 is illustrated a general arrangement effective for the oxidation protection of structural members used in high temperature applications. In such applications the member to be protected is enclosed or confined within a protective casing or chamber which is provided with the oxygen-buffering material described. It will be understood that the material to be protected may be of any desired or selected size and shape and may, for example, be a metal or alloy or a refractory compound of an element of group 3, 4 or 5 or other oxidizable material susceptible to protection by the method of the invention. In such structures the element 1 to be protected against oxidation is mounted within an enclosed or confined space established by a seal 2 and an exterior shield or casing 4 providing a space for the reception of a selected buffering material 3. The exterior shield or casing 4 may be of any high temperature material of good oxidation resistance such as refractory oxide ceramics, suitable metals, special carbon or other structural material adapted to withstand the internal or external environment conditions encountered in use.

The member 2 may be elastomeric material or a mechanical seal so constructed and arranged as to permit relative sliding movement on element 1 and/or casing 4 to allow for different thermal expansion between element 1 and casing 4.

The buffering system designated at 3, as described previously, may be carbon in any form, a carbon-producing substance, such as paper, a carbide, a metal or other material or mixtures thereof which are oxidizable preferentially to element 1. Preferably, the buffering material comprises a carbon-containing substance which, under the thermal conditions obtaining during use, can develop and maintain a CO-CO₂ reducing atmosphere with low partial pressure of oxygen in the area adjacent element 1.

In FIG. 2 is illustrated an electrical resistance wire element which is protected in accordance with the principles of the invention. The wire may be of any desired size or gauge and as illustrated comprises a wire element 5 mounted within a chamber defined by the external casing or tube 6, and interior tube 7 and the seals or closures 8 within which chamber is provided a buffering material 9 of the type and character hereinbefore defined.

The resistance wire 5 may be comprised of molybdenum, tungsten, columbium, tantalum, iron, chromium, nickel, cobalt or alloys thereof. The tubes 6 and 7 may be of any high temperature material with good oxidation resistance such as oxide ceramics, metal or special carbon, or other structural material capable of withstanding the thermal conditions encountered in use. The seal 8, like seal 2 of FIG. 1, may be an

elastomeric or mechanical seal permitting sliding movement along the tubes; the buffering material may be the same as that described in the discussion of FIG. 1.

FIG. 3 illustrates another application of the invention, namely, for the production of a rod heater of increased effective life in which the wire element is protected in accordance with the invention.

In this structure the wire element 10 is enclosed within a chamber formed by a tubular casing 11 and end seals or closures 12 within which chamber is provided the described novel buffering material 13. The casing or tube may be composed of an oxide ceramic, metal, carbon, or other suitable material capable of withstanding the environment of use. In the particular application the end seals 12 may be such as to provide for sliding movement and may comprise elastomeric or mechanical closures or they may be rigid permanently fixed mechanical seals.

It is to be observed that the maximum temperature of usefulness in the structures disclosed is often set by the melting point of the housing or enclosure within which the element to be protected by the buffer is mounted. Thus, for example, when the item 4 of FIG. 1 is composed essentially of aluminum oxide, the maximum temperature of usefulness is approximately 3,750° F. For use at temperatures approaching 4,600° F. such elements may be composed of beryllium oxide. When temperatures up to 4,800° F. are to be encountered, a more refractory material, such as zirconium oxide should be employed in such constructions. At higher temperatures, up to about 5,800° F. thorium oxide is a material of choice.

The maximum temperature of usefulness is also related to the character or composition of the element to be protected, as for example, the electrical-heating elements previously described. Such elements composed of iron, chromium, nickel, cobalt or their alloys would be limited to use at temperatures up to a maximum of 2,880° F. Such elements composed of molybdenum, tungsten, tantalum, columbium or alloys thereof would have a wider range of usefulness, i.e., up to 6,100° F.

FIG. 4 illustrates an electrical resistance carbide-heating element embodying the protective features of the invention. The structure includes an element 15 mounted within a chamber defined by the refractory tube or casing 16 and closures 17 in which chamber an oxygen protective or buffering material 18, previously described, is provided. The element 15 may be silicon carbide, tantalum carbide, or other suitable semiconductive resistance material. The casing 16 may be a high temperature material as described in FIGS. 1, 2 and 3. The closure 17 may be an elastic or mechanical seal which permits relative movement of element 15 and casing 16 to allow for differences in expansion between these two. The oxygen-buffering material 18 may be of the types described in the discussion of FIGS. 1, 2 and 3.

In FIG. 5 is illustrated an electrical resistance silicide-type of heating element protected in accordance with the invention. Such a unit comprises a casing 20 of high temperature material, such as oxide ceramic, metal, carbon and the like, and is designed to receive a heating element 21, such for example, as molybdenum disilicide or other equivalent semiconductive material. The casing or housing 20 is closed by a seal 22 through which the terminals of the elements 21 project; such seal may be of the same material as that used in the casing 20 and may be rigid with such casing. As shown, the chamber of the casing is provided with an oxygen buffering material of the type previously described and adapted to function to protect element 21 against infiltrated air by preferentially reacting the contained oxygen to reduce the partial pressure of such oxygen in the area in which the element 21 is housed.

Dependent upon the maximum temperature of usefulness, as explained previously, in respect to the units disclosed in FIGS. 1-3, the casing 20 may be composed of special carbon, aluminum oxide, zirconium oxide, beryllium oxide, and thorium oxide, or, when circumstances dictate, may be constituted of platinum, rhodium, rubidium, iridium, or alloys thereof.

The buffering material employed is selected so as to be most effective and compatible at the maximum temperatures on the particular units described. Thus when such temperature is of the order of up to 3,700° F. such buffer may comprise carbon or carbon-producing material, aluminum carbide, carbon together with aluminum carbide or aluminum oxide or mixtures of all three of these materials. At temperatures up to approximately 4,600° F. the buffering agent may comprise carbon or carbon-forming material, beryllium carbide, carbon together with beryllium carbide or beryllium oxide or mixtures of these three components. At temperatures up to approximately 4,800° F. such buffering agent may advantageously be comprised of carbon or carbon-forming material, zirconium carbide, carbon together with zirconium oxide or zirconium carbide or mixtures of all three. At higher temperatures, up to approximately 5,800° F. the buffering material may be comprised of carbon or carbon-forming material, thorium carbide, carbonaceous material together with thorium oxide or thorium carbide or mixtures of all three of these components.

It will thus be appreciated that the described invention provides a novel, effective method of protecting oxidizable materials at high temperatures, thus insuring long-lasting high temperature performance of such materials by insuring a low partial pressure of oxygen in the atmosphere to which such materials are normally subjected. As noted, the concept of the invention can be invoked to protect, and thereby prolong, the effective life of structural materials used at high temperatures and is of special utility for use in electrically heated furnaces. Furnaces to which the method of the invention is applicable are, generally considered, of three basic types, low temperature furnaces heated by cobalt-chromium, nickel-chromium and iron-chromium-aluminum-cobalt alloys; moderate temperature laboratory or processing furnaces; and high temperature laboratory or processing furnaces heated by refractory metals, such as molybdenum, tungsten, columbium, tantalum or alloys thereof; some of which high temperature furnaces employ a hydrogen atmosphere or water cooling.

The described method of generating a C-CO-CO₂ equilibria in situ in a confined region contiguous to the element to be protected can be used to particular advantage in each of the above types of furnaces. It enables the operation of low temperature furnaces at temperatures that more closely approximate the melting temperature of the alloys employed. As now used, the temperature of usefulness of such furnaces is limited by oxidation of the electrical-heating element rather than the melting points. Similarly, the invention is of particular utility when employed in a moderate temperature type furnace because the desired temperature can be obtained by eliminating the expensive and difficult-to-obtain noble metals, replacing them with cheaper metals or alloys. Use of the method in the third type high temperature furnace is advantageous because it eliminates the need and hazards of employing gaseous hydrogen and in some cases eliminates the need of water cooling.

It will be appreciated by those skilled in the art that the described method utilizing the C-CO-CO₂ equilibrium concept for the protection of structural components and electrical-heating elements under high temperature conditions is more safe and economical as compared, for example, to the use of hydrogen introduced from sources external to the element to be protected. Furthermore, the concept lends itself to relatively easy replacement of the equilibrium-generating material when necessary.

While preferred embodiments of the invention have been described, it is to be understood that these are given didactically to explain the fundamental concept and not as limiting the useful scope of the invention to the particular examples described, except that such limitations are clearly imposed by the appended claims.

I claim:

1. An electrical furnace comprising a chamber adapted to receive a workpiece, a casing of high temperature material surrounding and spaced from said chamber, seal means connected between said chamber and casing at opposite ends and

defining a sealed interior area of limited size between the chamber and casing, an electrical-heating element comprised of materials oxidizable at very high temperatures and connected to terminals exterior of the seal means and an oxygen-buffering material within the area and adapted to generate and maintain a CO-CO₂ reducing atmosphere at very high temperatures by reaction with oxygen diffusing through said casing.

2. A furnace according to claim 1 in which the buffering agent includes oxygen reactive carbonaceous material.

3. A furnace according to claim 1 in which the buffering agent includes oxygen reactive metallic materials.

4. A furnace according to claim 1 in which said oxidizable material includes metals and alloys and compounds of ele-

ments of group 3, 4 and 5 of the Periodic Table.

5. A furnace according to claim 1 in which said oxidizable material comprises furnace elements.

6. A furnace according to claim 1 in which very high temperatures include temperatures in the range of the order of 1,500° F. to 5,800° F.

7. A furnace according to claim 1 in which the said oxidizable materials are chosen from the group consisting of molybdenum, tungsten, tantalum, columbium, iron, chromium, nickel, cobalt and alloys thereof.

8. A furnace according to claim 1 in which the buffering agent includes carbonaceous materials and oxides and carbides of aluminum, zirconium, beryllium and thorium.

15

20

25

30

35

40

45

50

55

60

65

70

75