

Oct. 23, 1934.

J. F. MARTIN

1,978,162

TIMER FOR INTERNAL COMBUSTION ENGINES

Filed Oct. 7, 1933

2 Sheets-Sheet 1

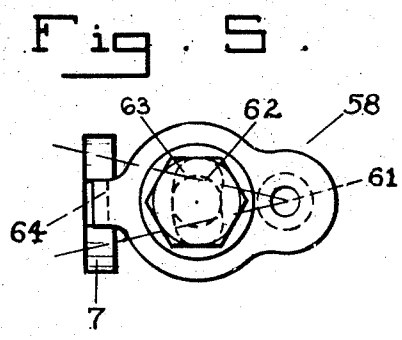
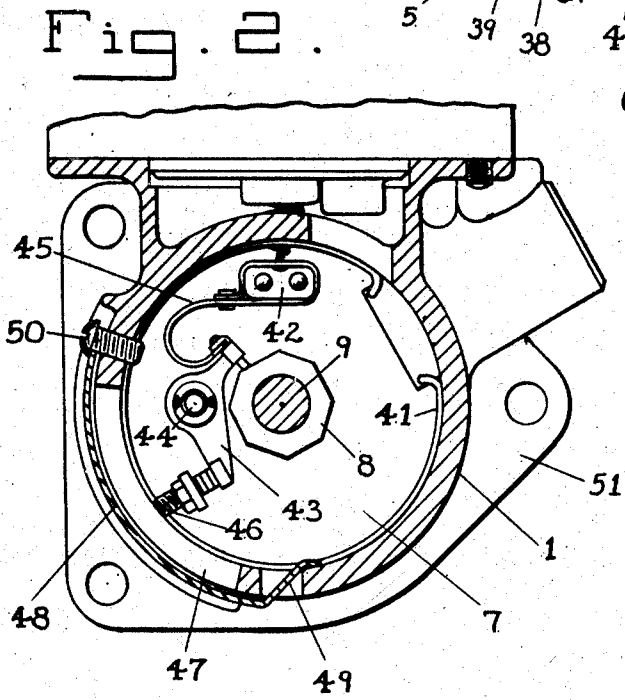
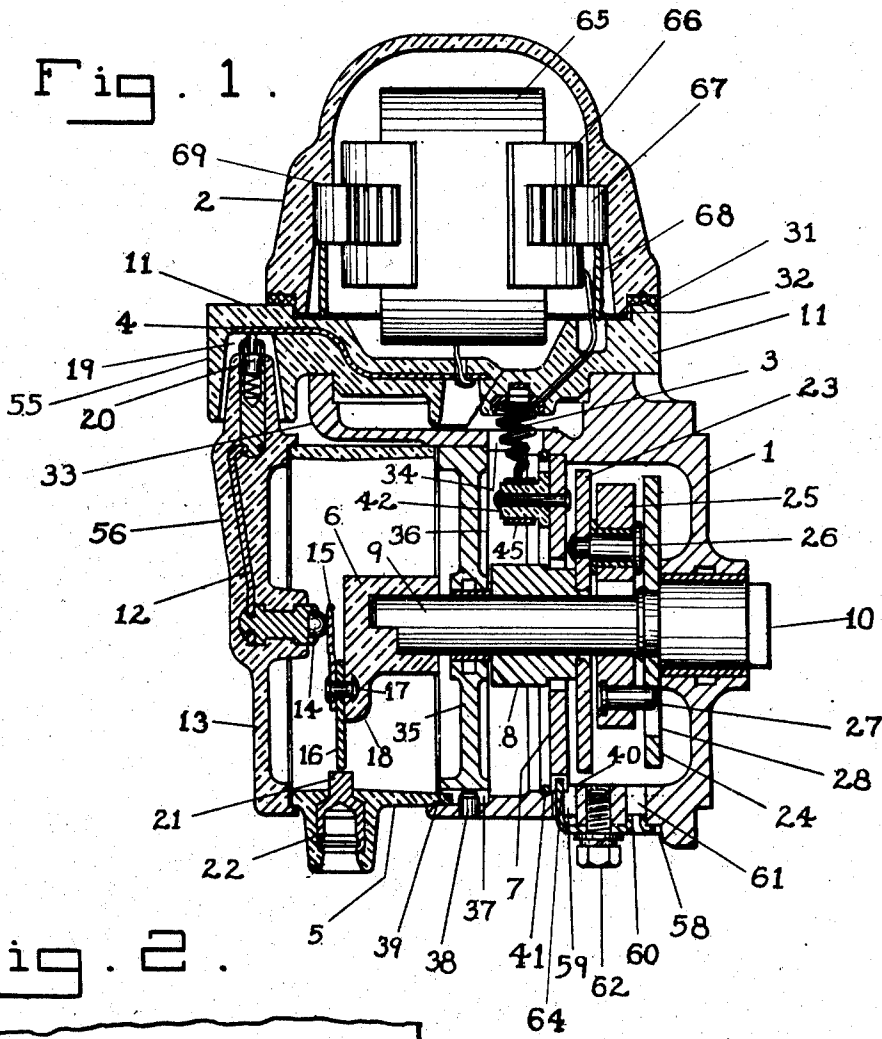

INVENTOR.  
*John F. Martin*  
 BY *Sam A. Brantley*  
 ATTORNEY.

Oct. 23, 1934.

J. F. MARTIN

1,978,162

TIMER FOR INTERNAL COMBUSTION ENGINES

Filed Oct. 7, 1933

2 Sheets-Sheet 2

Fig. 3.

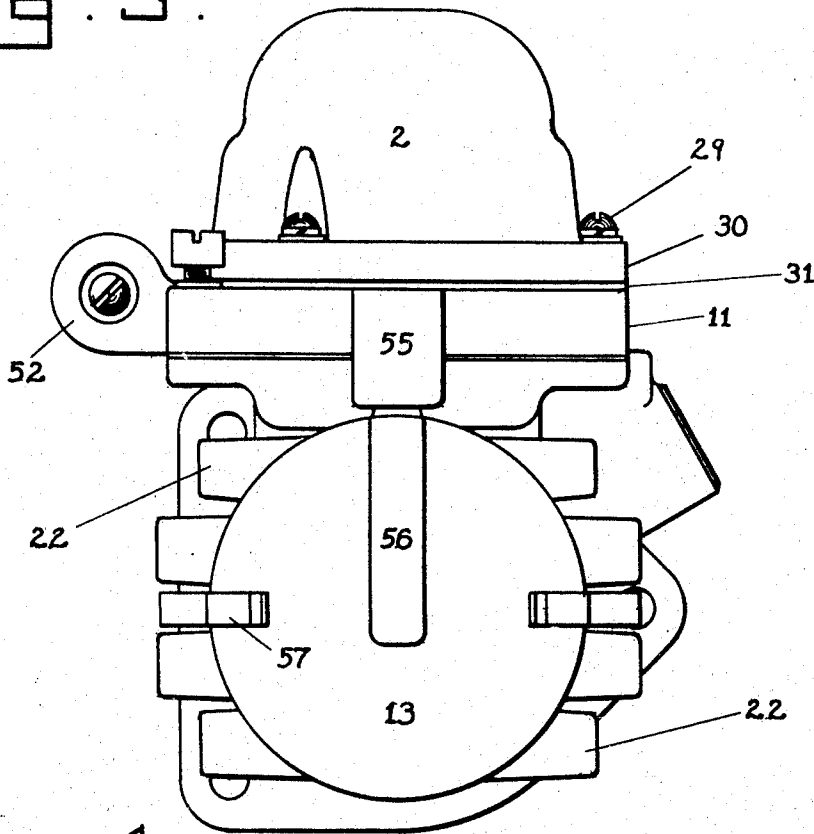

Fig. 4.

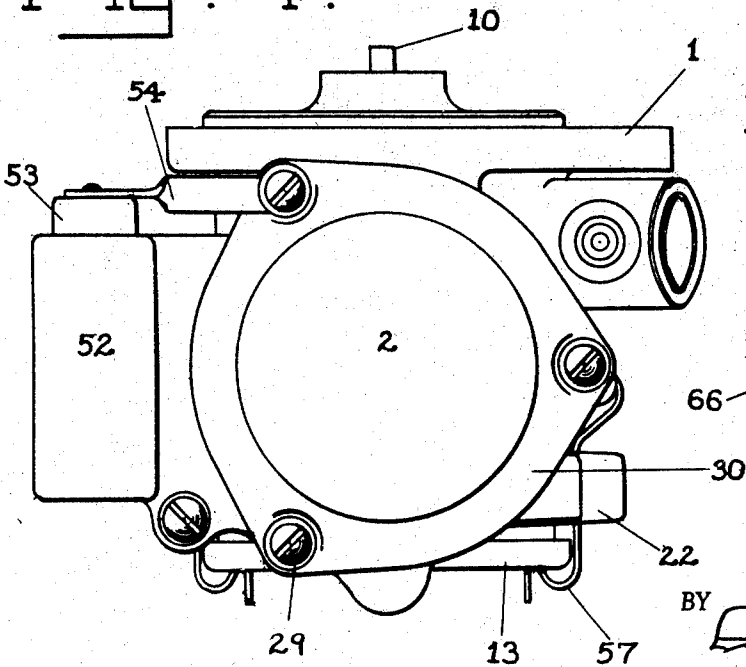
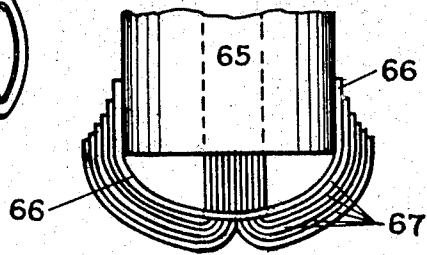

Fig. 6.



INVENTOR.

John F. Martin

BY

*Dean H. Rosenthal*

ATTORNEY.

# UNITED STATES PATENT OFFICE

1,978,162

## TIMER FOR INTERNAL COMBUSTION ENGINES

John F. Martin, Springfield, Mass., assignor to  
United American Bosch Corporation, Spring-  
field, Mass., a corporation of New York

Application October 7, 1933, Serial No. 692,593

6 Claims. (Cl. 123—148)

My invention relates to timers for the ignition circuits of internal combustion engines.

An object of this invention is to provide a timer with a housing enclosing a low tension circuit breaker and a distributor, and a cover for an ignition coil secured on the casing; the entire construction being compact and simple, easy to assemble and attach to the engine for which it is intended, and inexpensive to produce.

The objects and advantages of the invention are set forth in the ensuing description, but I reserve, of course, the right to make changes in details that do not depart from the spirit of the invention or exceed the scope and meaning of the broad terms in which the claims are expressed.

On the drawings:

Fig. 1 is an axial section through a timer according to my invention;

Figure 2 is a transverse section through a part thereof showing the circuit breaker;

Fig. 3 is a front view;

Fig. 4 is a top view thereof; and

Figs. 5 and 6 show details.

The numeral 1 indicates a metal housing for the timer of suitable material on the top of which is a cover 2 containing the primary and secondary windings of a high tension ignition coil, one terminal of the primary of this coil being connected to a suitable source of electrical energy associated with the engine, and the other extremity of the primary being connected to a terminal 3 by which it is joined to the interrupter or circuit breaker of the timer in the housing 1. Of the secondary coil, one end will be grounded in the usual way, and the other end will be joined to a brush or suitable terminal 4 adjacent the base of the cover 2 to enable high tension current to be conducted to the distributor of the timer. The casing of the distributor is shown at 5. This casing 5 as well as the cover 2 will be preferably of some suitable insulating material, and inside of the casing 5 is the rotor 6 of the timer. The supporting plate for the circuit breaker is shown at 7 in the housing 1 and it has a pair of contacts, one fixed and the other movable; the latter to be actuated by a cam 8 on a shaft 9 in the housing 1 so as to open the circuit of the timer at each instant of ignition. The shaft 9 is mounted in a suitable bearing in the bottom or rear wall of the housing 1 and is adapted to be connected by means of a tongue 10 at its outer end to an operating shaft of the engine to rotate the cam 8 and rotor 6. The high tension terminal 4 is embedded in a molded top 11 between the housing 1 and the bottom of the coil cover 2. It is connected with

a conductor strip 12 embedded in a cap 13 for the casing 5 and leading to a central brush 14 on the inside of this cap. This terminal 14 engages a spring conductor 15 on the rotor 6, which is also of insulation and this rotor carries thereon a brush or terminal 16. A rivet 17 embedded in the arm 18 of the rotor secures the conductor 15 in contact with the brush 16 and affixes both to the rotor 6. Of course the cap 13 is of insulation.

The molded top of insulation 11 has a recess 19 opening through its lower face, and the end of the conductor 4 is exposed at the bottom of this recess to be engaged by a spring-pressed brush 20, in a socket embedded in the cap 13 and secured to one end of the conductor 12.

At 21 are shown fixed high tension terminals carried by the distributor casing 5 through which the circuit is closed in turn by the brush 16. These terminals extend through the casing 5 from the inside to the outside; being hollow at their outer ends and enclosed in hollow projections 22 on the casing 5 to receive the ends of the high tension terminals leading to the spark plugs.

The shaft 9 with driving key 10 carries a governor comprising a loose plate 23 and a fixed plate 24 between the breaker plate and the closed end of the housing. Attached to the plate 23 are governor weights 25 pivotally mounted on pins 26 carried by the plate 23. These governor weights carry pins 27 which engage slots 28 of suitable shape in the plate 24. The cam 8 is rigid with the shiftable plate 23 so that when the speed increases the cam is advanced with respect to the shaft 9.

The cover 2 is secured in place by screws 29 passing through openings in the lower part 30 of the cover 2 and top 11 into engagement with threaded bores in the top of the housing 1. Between the cover 2 and the top 11 is a packing ring 31 and the upper face of the top 11 is counterbored slightly to receive a rim 32 on the cover 2.

The top of the housing 1 has an extension 33 on which the molded element 11 rests and the top of the housing has an opening 34 to give passage to the terminal 3. The front end of the housing 1 is open but receives a disk 35 which fits against an inside shoulder 36. The rim of the casing 5 enters this end of the housing and abuts the disk 35. This disk has a keyway 37 in its periphery which engages a projection 38 in the housing and the casing 5 has a projection 39 which also enters this keyway and enables the casing 5 to be fitted to the housing 1 in central position with the sockets 22 at each side of the timer. The supporting plate 7 for the interrupter fits against

a shoulder 40 between the governor and the disk 35 and has an opening to give clearance to the cam 8. This plate 7 is held against the shoulder 40 by a spring ring 41 which is received in an inside groove in the housing 1.

The plate 7 has secured to the face thereof by one or more rivets a piece of insulation 42. At 43 is an interrupter lever preferably of metal having a contact at one end and mounted between its ends on a pivot stud 44 affixed to the plate 7. Adjacent the other end is the usual rubbing block to be engaged by the cam 8 and at 45 is a spring which is affixed to said other extremity of the lever 43 and to the insulation 42, the lower end of the terminal 3 being connected to this spring. A terminal on the end of the lever 43 engages a fixed terminal 46. Preferably the lever 43 is insulated from its pivot stud 44 and the fixed terminal 46 is grounded on the plate 7. Then the primary circuit is opened whenever the cam 8 moves the lever 43 to disengage its contact from the contact 46.

At the side of the housing 1 adjacent the plate 7 is an opening 47 which is closed by a curved strip of metal 48 on the outside of the housing. One end of this strip passes through an opening 49 and engages the inner face of the housing and the other end is made fast by a screw 50. When the screw 50 is taken out, the opening 47 can be uncovered for inspection and repair of the circuit breaker.

The housing 1 has at the closed end thereof a flange 51 with openings for mounting screws. The molded top 11 has a socket 52 to receive a condenser 53 and at 54 is a conductor united to the insulated pole of the condenser to be properly connected to the same terminal of the primary winding that leads to the circuit breaker and thus bridge the breaker contacts. The molded top 11 has a projection 55 in which is located the recess 19 and the cap 13 may have a thickened portion 56 in which the strip 12 is embedded. At 57 are spring clips pivoted to the sides of the housing 1 in position to engage the cap 13 and hold this cap in place.

The lower end of the supporting plate 7 may have a notch therein to receive the inturred end of an adjuster plate 58 which passes through an opening 59 in the bottom of the housing 1. This element 58 holds the plate 7 in a position of fine adjustment. It is punched to provide a pivot 60 which fits into an opening 61 to enable the inturred end of this element 58 to be turned somewhat in the recess 59 and it is held fast by means of a screw 62. This screw passes through an enlarged opening in the element 58 so that the element can be moved sidewise with respect to this screw 62 and locked in desired position. Said opening is indicated at 63 in the form of a slot in the element 58 and the inturred end of this element engaging the timer plate is indicated at 64.

The coil 65 in the cover 2 comprises primary and secondary windings with insulating pieces 66 at the ends and a central laminated core consisting of strips of magnetic material 67. This core is substantially parallel to the top 11. At its ends the strips are bent laterally towards each side of the coil against the insulating pieces 66.

At 68 is an insulating tube which may rest on the top 11 and support the core and coil. The inside of the cover 2 may have a shoulder 69 which engages the outer ends of the core, and holds the coil between it and the tube 68. The insulation pieces 66 of course are perforated to let the ends of the laminations of core 67 go through them before bending.

Having described the invention what is claimed is:

1. A timer comprising a housing, a top of molded insulation on the housing, a coil on said top, a cover for the coil, a distributor casing mounted on the housing, a cap for said casing, embedded conductors in the top and the cap to convey current from the coil to the distributor casing, said top having a recess, and the cap having a projection to enter said recess, the ends of said conductors being in engagement within said recess.

2. A timer comprising a housing, a circuit breaker plate within the housing, an adjuster element on said housing, said element being pivoted to the exterior of the housing, said housing having an opening through which an end of the element projects, the circuit breaker plate having a recess receiving said end, said element having a transverse slot therein between said end and the pivot point and a fastening bolt engaging the housing and passing through said slot.

3. A timer comprising a housing, a circuit breaker plate therein, and an adjusting element pivotally mounted on the housing to maintain the plate in desired position, said element having a pivot punched therefrom and an overturned end to engage said plate, and a transverse slot therein to give passage to a fastening bolt.

4. A timer comprising a housing, a shaft having a bearing in one end of the housing, circuit breaking means encircling said shaft, a distributor casing at the opposite end of the housing, a bearing disk in the housing between the distributor casing and the circuit breaking means, said disk having a key-way, a projection carried by the housing to engage the key-way and a projection on the distributor casing to enter said key-way.

5. A timer comprising a housing, a molded insulating top on the housing, a coil on the top, a distributor casing on the housing, said casing having a projection to enter a key-way carried by a part of the housing, to hold the casing in proper position, a cap for the casing, circuit breaking means in the housing, and enclosed connections leading from the coil to the circuit breaking means and the distributor casing, said connections comprising conductors embedded in the top and cap.

6. A timer comprising a housing, a top of molded insulation on said housing, a coil on said top, a distributor casing, a hollow projection extending laterally from said top and having a downwardly opening recess, a conductor embedded in said top having an exposed part within said projection, and conducting means projecting into contact with said exposed portion and connected to said distributor.

JOHN F. MARTIN.