



(12) **CORRECTED NEW EUROPEAN PATENT SPECIFICATION**

Note: Bibliography reflects the latest situation

- (15) Correction information:
Corrected version no 1 (W1 B2)
Corrections, see page(s) 14-16, 19-22, 25-28
- (48) Corrigendum issued on:
26.01.2005 Bulletin 2005/04
- (45) Date of publication and mention of the opposition decision:
01.09.2004 Bulletin 2004/36
- (45) Mention of the grant of the patent:
30.07.1997 Bulletin 1997/31
- (21) Application number: **92920904.7**
- (22) Date of filing: **02.10.1992**
- (51) Int Cl.7: **F01N 3/18, F01N 3/24**
- (86) International application number:
PCT/JP1992/001279
- (87) International publication number:
WO 1993/007363 (15.04.1993 Gazette 1993/10)

(54) **DEVICE FOR PURIFYING EXHAUST OF INTERNAL COMBUSTION ENGINE**

GERÄT ZUM REINIGEN VON VERBRENNUNGSMOTOR-ABGASEN

DISPOSITIF POUR PURIFIER LES GAZ D'ÉCHAPPEMENT D'UN MOTEUR A COMBUSTION INTERNE

- | | | | | | | | | | | | | | | | | | |
|--|---|------------------------|------------------------|------------------------|------------------------|------------------------|------------------------|------------------------|------------------------|-------------------------|-------------------------|-------------------------|-------------------------|-------------------------|-------------------------|-------------------------|--|
| <p>(84) Designated Contracting States:
DE ES FR GB IT SE</p> <p>(30) Priority: 03.10.1991 JP 28190791
04.10.1991 JP 28409591</p> <p>(43) Date of publication of application:
22.09.1993 Bulletin 1993/38</p> <p>(73) Proprietor: TOYOTA JIDOSHA KABUSHIKI KAISHA
Toyota-shi, Aichi-ken 471-8571 (JP)</p> <p>(72) Inventors:
 <ul style="list-style-type: none"> • TAKESHIMA, Shinichi
Susono-shi, Shizuoka 410-11 (JP) • NAKANISHI, Kiyoshi
Susono-shi, Shizuoka 410-11 (JP) • IGUCHI, Satoshi
Mishima-shi, Sizuoka 411 (JP) • TANAKA, Toshiaki
Numazu-shi, Sizuoka 410 (JP) • ARAKI, Yasushi
Susono-shi, Sizuoka 410-11 (JP) • HIROTA, Shinya
Susono-shi, Sizzoka 410-11 (JP) • KOBASHI, Kiyoshi
Mishima-shi, Sizuoka 411 (JP) </p> | <p>(74) Representative:
Leson, Thomas Johannes Alois, Dipl.-Ing. et al
TBK-Patent,
P.O. Box 20 19 18
80019 München (DE)</p> <p>(56) References cited:</p> <table border="0"> <tr> <td>EP-A- 0 272 136</td> <td>EP-A- 0 351 197</td> </tr> <tr> <td>EP-A- 0 503 882</td> <td>EP-A- 0 540 280</td> </tr> <tr> <td>JP-A- 1 134 020</td> <td>JP-A- 2 149 346</td> </tr> <tr> <td>JP-A- 3 016 641</td> <td>JP-A- 4 004 044</td> </tr> <tr> <td>JP-A- 59 188 053</td> <td>JP-A- 60 164 642</td> </tr> <tr> <td>JP-A- 61 181 538</td> <td>JP-A- 62 106 826</td> </tr> <tr> <td>JP-A- 62 117 620</td> <td>JP-A- 63 270 543</td> </tr> <tr> <td>JP-U- 63 038 619</td> <td></td> </tr> </table> <ul style="list-style-type: none"> • PATENT ABSTRACTS OF JAPAN vol. 11, no. 317 (C-452)15 October 1987 & JP-A-62 106 826 (NIPPON SHOKUBAI KAGAKU KOGYO CO LTD) 18 May 1987 • PATENT ABSTRACTS OF JAPAN vol. 015, no. 345 (C-0864)3 September 1991 & JP-A-03 135 417 (MATSUSHITA ELECTRIC IND CO LTD) 10 June 1991 • SAE Paper 780607 • SAE of Japan, Paper 882087 • JCCCAT, 1990, pages 1165 and 1166 • SAE Paper 881595 | EP-A- 0 272 136 | EP-A- 0 351 197 | EP-A- 0 503 882 | EP-A- 0 540 280 | JP-A- 1 134 020 | JP-A- 2 149 346 | JP-A- 3 016 641 | JP-A- 4 004 044 | JP-A- 59 188 053 | JP-A- 60 164 642 | JP-A- 61 181 538 | JP-A- 62 106 826 | JP-A- 62 117 620 | JP-A- 63 270 543 | JP-U- 63 038 619 | |
| EP-A- 0 272 136 | EP-A- 0 351 197 | | | | | | | | | | | | | | | | |
| EP-A- 0 503 882 | EP-A- 0 540 280 | | | | | | | | | | | | | | | | |
| JP-A- 1 134 020 | JP-A- 2 149 346 | | | | | | | | | | | | | | | | |
| JP-A- 3 016 641 | JP-A- 4 004 044 | | | | | | | | | | | | | | | | |
| JP-A- 59 188 053 | JP-A- 60 164 642 | | | | | | | | | | | | | | | | |
| JP-A- 61 181 538 | JP-A- 62 106 826 | | | | | | | | | | | | | | | | |
| JP-A- 62 117 620 | JP-A- 63 270 543 | | | | | | | | | | | | | | | | |
| JP-U- 63 038 619 | | | | | | | | | | | | | | | | | |

- Taylor et al.;"Behavior of Automobile Exhaust Catalysts with Cycled Feedstreams", Industrial & Engineering Chemistry Products Research and Development, Vol.22, March 1983, pages 45-51

Description

TECHNICAL FIELD

[0001] The present invention relates to an exhaust purification device of an internal combustion engine.

[0002] A diesel engine in which an engine exhaust passage is branched to a pair of exhaust branch passages for purifying NO_x, a switching valve is disposed at the branched portion of these exhaust branch passages to alternately guide the exhaust gas to one of the exhaust branch passages by a switching function of the switching valve, and a catalyst which can oxidize and absorb the NO_x is disposed in each of the exhaust branch passages is well known (refer to Japanese Unexamined Patent Publication No. 62-106826). In this diesel engine, NO_x in the exhaust gas introduced into one exhaust branch passage is oxidized and absorbed by the catalyst disposed in that exhaust branch passage. During this time, the inflow of the exhaust gas to the other exhaust branch passage is stopped and, at the same time, a gaseous reducing agent is fed into this exhaust branch passage. The NO_x accumulated in the catalyst disposed in this exhaust branch passage is reduced by this reducing agent. Subsequently, after a short time, the introduction of the exhaust gas to the exhaust branch passage to which the exhaust gas had been introduced heretofore is stopped by the switching function of the switching valve, and the introduction of the exhaust gas to the exhaust branch passage to which the introduction of the exhaust gas had been stopped heretofore is started again.

[0003] However, when the introduction of the exhaust gas to a pair of exhaust branch passages is alternately stopped, the temperature of the catalyst in the exhaust branch passage on the side where the introduction of the exhaust gas was stopped is gradually lowered in the period where the introduction of the exhaust gas is stopped and is lowered to a considerably low temperature near the time when the introduction of the exhaust gas is started again. When the temperature of the catalyst becomes low in this way, there arises a problem in that the catalytic function of the catalyst is lowered, and therefore the oxidation and absorption function of NO_x is not sufficiently carried out. In the period from when the introduction of the exhaust gas is started to when the catalyst temperature rises, the NO_x is not absorbed by the catalyst and thus is discharged to the atmosphere.

[0004] Also, in this diesel engine, a pair of exhaust branch passages must be provided, and a switching valve becomes necessary. Therefore, the construction becomes complex. Further, the switching valve is always exposed to the high temperature exhaust gas, and therefore there arises a problem of durability of the switching valve. Also, from the viewpoint of the absorption of NO_x, one catalyst is always idle, and therefore there is another problem such that the entire catalyst

which is provided is not effectively utilized for the absorption of NO_x.

[0005] From the JP3135417 a NO_x removing device is known which comprises an NO_x absorbent being disposed in an exhaust passage of an engine for storing NO_x. The exhaust gas continuously flows into the NO_x absorbent during an operation of the engine. A high temperature gas generation unit is provided which generates a high temperature gas of low O₂ concentration. By this gas, the NO_x is released from the absorbent and passed through a reduction catalyst in which the NO_x is decomposed into N₂ and O₂. In the device according to the JP3135417 a separate high temperature generation unit and a reduction unit is necessary in order to reduce the NO_x, additional to the absorbent unit.

DISCLOSURE OF THE INVENTION

[0006] An object of the present invention is to provide an exhaust purification device which can efficiently absorb NO_x without a complex construction of the exhaust system and can release the absorbed NO_x according to need. This object is achieved by the features according to claim 1 in each of the versions for the different designated states.

[0007] Further improvements are the subject-matter of the appended dependent claims.

BRIEF DESCRIPTION OF THE DRAWINGS

[0008] Figure 1 is an overall view of an internal combustion engine; Fig. 2 is a diagram showing a map of a basic fuel injection time; Fig. 3 is a diagram showing a change of a correction coefficient K; Fig. 4 is a graph schematically showing the concentration of unburnt HC and CO in the exhaust gas and oxygen discharged from the engine; Fig. 5 is a diagram for explaining an absorption and releasing operation of the NO_x; Fig. 6 is a diagram showing an absorption rate of NO_x; Fig. 7 is a diagram showing a control of the air-fuel ratio; Fig. 8 is a flow chart showing an interruption routine; Fig. 9 is a flow chart for calculating a fuel injection time TAU; Fig. 10 is an overall view showing another embodiment of the internal combustion engine; Fig. 11 is a graph showing an output of the air-fuel ratio sensor; Fig. 12 is a flow chart for calculating a feedback correction coefficient F; Fig. 13 is a flow chart for calculating the fuel injection time TAU; Fig. 14 is an overall view showing still another embodiment of the internal combustion engine; Fig. 15 is an overall view showing still another embodiment of the internal combustion engine; Fig. 16 is an overall view showing further still another embodiment of the internal combustion engine; Fig. 17 is a flow chart showing an interruption routine; Fig. 18 is a flow chart showing a main routine; Fig. 19 is an overall view showing furthermore still another embodiment of the internal combustion engine; and Fig. 20 is a flow chart for performing the NO_x releasing processing.

BEST MODE FOR CARRYING OUT THE INVENTION

[0009] Figure 1 shows a case where the present invention is applied to a gasoline engine.

[0010] Referring to Fig. 1, 1 denotes an engine body; 2 a piston; 3 a combustion chamber; 4 a spark plug; 5 an intake valve; 6 an intake port; 7 an exhaust valve; and 8 an exhaust port, respectively. The intake port 6 is connected to a surge tank 10 via a corresponding branch pipe 9, and a fuel injector 11 injecting the fuel toward the interior of the intake port 6 is attached to each branch pipe 9. The surge tank 10 is connected to an air cleaner 14 via an intake duct 12 and an air flow meter 13, and a throttle valve 15 is disposed in the intake duct 12. On the other hand, the exhaust port 8 is connected via an exhaust manifold 16 and an exhaust pipe 17 to a casing 19 including the NO_x absorbent 18 therein.

[0011] An electronic control unit 30 comprises a digital computer and is provided with a ROM (read only memory) 32, a RAM (random access memory) 33, a CPU (microprocessor) 34, an input port 35, and an output port 36, which are interconnected by a bidirectional bus 31. The air flow meter 13 generates an output voltage proportional to the amount of intake air, and this output voltage is input via an AD converter 37 to the input port 35. A temperature sensor 20 generating an output voltage proportional to the exhaust temperature is attached in the exhaust pipe 17 upstream of the casing 19, and the output voltage of this temperature sensor 20 is input via the AD converter 38 to the input port 35. Also, an engine speed sensor 21 generating an output pulse expressing the engine speed is connected to the input port 35. On the other hand, the output port 36 is connected via the corresponding driving circuits 39 and 40 to the spark plug 4 and fuel injector 11, respectively.

[0012] In the internal combustion engine shown in Fig. 1, the fuel injection time TAU is calculated based on for example the following equation.

$$TAU = TP \cdot K$$

where, TP is a basic fuel injection time, and K is a correction coefficient. The basic fuel injection time TP shows the fuel injection time necessary for bringing the air-fuel ratio of an air-fuel mixture fed into the engine cylinder to the stoichiometric air-fuel ratio. This basic fuel injection time TP is found in advance by experiments and is stored in advance in the ROM 32 in the form of a map as shown in Fig. 2 as the function of an engine load Q/N (intake air amount Q/engine speed N) and the engine speed N. The correction coefficient K is a coefficient for controlling the air-fuel ratio of the air-fuel mixture fed into the engine cylinder, and if K = 1.0, the air-fuel ratio of the air-fuel mixture fed into the engine cylinder becomes the stoichiometric air-fuel ratio. Contrary to this, when K becomes smaller than 1.0, the air-fuel ratio of the air-fuel mixture fed into the engine cylinder

becomes larger than the stoichiometric air-fuel ratio, that is, becomes lean, and when K becomes larger than 1.0, the air-fuel ratio of the air-fuel mixture fed into the engine cylinder becomes smaller than the stoichiometric air-fuel ratio, that is, becomes rich.

[0013] This correction coefficient K is controlled in accordance with the operating state of the engine. Figure 3 shows one embodiment of the control of this correction coefficient K. In the embodiment shown in Fig. 3, during a warm-up operation, the correction coefficient K is gradually lowered as the engine cooling water temperature becomes higher. When the warm-up is completed, the correction coefficient K is maintained at a constant value smaller than 1.0, that is, the air-fuel ratio of the air-fuel mixture fed into the engine cylinder is maintained as lean. Subsequently, when an acceleration operation is carried out, the correction coefficient K is brought to, for example, 1.0, that is, the air-fuel ratio of the air-fuel mixture fed into the engine cylinder is brought to the stoichiometric air-fuel ratio. When a full load operation is carried out, the correction coefficient K is made larger than 1.0. Namely, the air-fuel ratio of the air-fuel mixture fed into the engine cylinder is made rich. As seen from Fig. 3, in the embodiment shown in Fig. 3, except for the time of the warm-up operation, the time of the acceleration operation, and the time of the full load operation, the air-fuel ratio of the air-fuel mixture fed into the engine cylinder is maintained at a constant lean air-fuel ratio, and accordingly the lean air-fuel mixture is burned in a majority of the engine operation region.

[0014] Figure 4 schematically shows the concentration of representative components in the exhaust gas discharged from the combustion chamber 3. As seen from Fig. 4, the concentration of the unburnt HC and CO in the exhaust gas discharged from the combustion chamber 3 is increased as the air-fuel ratio of the air-fuel mixture fed into the combustion chamber 3 becomes richer, and the concentration of the oxygen O₂ in the exhaust gas discharged from the combustion chamber 3 is increased as the air-fuel ratio of the air-fuel mixture fed into the combustion chamber 3 becomes leaner.

[0015] The NO_x absorbent 18 contained in the casing 19 uses, for example, alumina as a carrier. On this carrier, at least one substance selected from alkali metals, for example, potassium K, sodium Na, lithium Li, and cesium Cs; alkali earth metals, for example, barium Ba and calcium Ca; rare earth metals, for example, lanthanum La and yttrium Y; and precious metals such as platinum Pt, is carried. When referring to the ratio between the air and fuel (hydrocarbons) fed into the intake passage of the engine and the exhaust passage upstream of the NO_x absorbent 18 as the air-fuel ratio of the inflow of exhaust gas to the NO_x absorbent 18, this NO_x absorbent 18 performs the absorption and releasing operation of NO_x by absorbing the NO_x when the air-fuel ratio of the inflow of exhaust gas is lean, while releasing the absorbed NO_x when the concentration of oxygen in the inflow of exhaust gas falls. Note that, where the fuel (hy-

drocarbons) or air is not fed into the exhaust passage upstream of the NO_x absorbent 18, the air-fuel ratio of the inflow of exhaust gas coincides with the air-fuel ratio of the air-fuel mixture fed into the combustion chamber 3, and accordingly in this case, the NO_x absorbent 18 absorbs the NO_x when the air-fuel ratio of the air-fuel mixture fed into the combustion chamber 3 is lean and releases the absorbed NO_x when the concentration of oxygen in the air-fuel mixture fed into the combustion chamber 3 is lowered.

[0016] When the above-mentioned NO_x absorbent 18 is disposed in the exhaust passage of the engine, this NO_x absorbent 18 actually performs the absorption and releasing operation of NO_x, but there are areas of the exact mechanism of this absorption and releasing operation which are not clear. However, it can be considered that this absorption and releasing operation is conducted by the mechanism as shown in Fig. 5. This mechanism will be explained by using as an example a case where platinum Pt and barium Ba are carried on the carrier, but a similar mechanism is obtained even if another precious metal, alkali metal, alkali earth metal, or rare earth metal is used.

[0017] Namely, when the inflow of exhaust gas becomes considerably lean, the concentration of oxygen in the inflow of exhaust gas is greatly increased. As shown in Fig. 5(A), the oxygen O₂ is deposited on the surface of the platinum Pt in the form of O₂⁻. On the other hand, the NO in the inflow of exhaust gas reacts with the O₂⁻ on the surface of the platinum Pt and becomes NO₂ (2NO + O₂ → 2NO₂). Subsequently, a part of the produced NO₂ is oxidized on the platinum Pt and absorbed into the absorbent. While bonding with the barium oxide BaO, it is diffused in the absorbent in the form of nitric acid ions NO₃⁻ as shown in Fig. 5(A). In this way, NO_x is absorbed into the NO_x absorbent 18.

[0018] So long as the oxygen concentration in the inflow of exhaust gas is high, the NO_x is produced on the surface of the platinum Pt, and so long as the NO_x absorption ability of the absorbent is not saturated, the NO_x is absorbed into the absorbent and nitric acid ions NO₃⁻ are produced. Contrary to this, when the oxygen concentration in the inflow of exhaust gas is lowered and the production of NO₂ is lowered, the reaction proceeds in an inverse direction (NO₃⁻ → NO₂), and thus nitric acid ions NO₃⁻ in the absorbent are released in the form of NO₂ from the absorbent. Namely, when the oxygen concentration in the inflow of exhaust gas is lowered, the NO_x is released from the NO_x absorbent 18. As shown in Fig. 4, when the degree of leanness of the inflow of exhaust gas becomes low, the oxygen concentration in the inflow of exhaust gas is lowered, and accordingly when the degree of leanness of the inflow of exhaust gas is lowered, the NO_x is released from the NO_x absorbent 18 even if the air-fuel ratio of the inflow of exhaust gas is lean.

[0019] On the other hand, at this time, when the air-fuel ratio of the air-fuel mixture fed into the combustion

chamber 3 is made rich and the air-fuel ratio of the inflow of exhaust gas becomes rich, as shown in Fig. 4, a large amount of unburnt HC and CO is discharged from the engine, and these unburnt HC and CO react with the oxygen O₂⁻ on the platinum Pt and are oxidized. Also, when the air-fuel ratio of the inflow of exhaust gas becomes rich, the oxygen concentration in the inflow of exhaust gas is extremely lowered, and therefore the NO₂ is released from the absorbent. This NO₂ reacts with the unburnt HC and CO as shown in Fig. 5(B) and is reduced. In this way, when the NO₂ no longer exists on the surface of the platinum Pt, the NO₂ is successively released from the absorbent. Accordingly, when the air-fuel ratio of the inflow of exhaust gas is made rich, the NO_x is released from the NO_x absorbent 18 in a short time.

[0020] Namely, when the air-fuel ratio of the inflow of exhaust gas is made rich, first of all, the unburnt HC and CO immediately react with the O₂⁻ on the platinum Pt and are oxidized, and subsequently if the unburnt HC and CO still remain even though the O₂⁻ on the platinum Pt is consumed, the NO_x released from the absorbent and the NO_x discharged from the engine are reduced by these unburnt HC and CO. Accordingly, when the air-fuel ratio of the inflow of exhaust gas is made rich, the NO_x absorbed in the NO_x absorbent 18 is released in a short time and in addition this released NO_x is reduced, and therefore the discharge of NO_x into the atmosphere can be blocked. Also, since the NO_x absorbent 18 has the function of a reduction catalyst, even if the air-fuel ratio of the inflow of exhaust gas is made the stoichiometric air-fuel ratio, the NO_x released from the NO_x absorbent 18 can be reduced. However, where the air-fuel ratio of the inflow of exhaust gas is made the stoichiometric air-fuel ratio, the NO_x is released merely gradually from the NO_x absorbent 18, and therefore a slightly long time is required for releasing all NO_x absorbed in the NO_x absorbent 18.

[0021] When the degree of leanness of the inflow of exhaust gas is lowered as mentioned before, even if the air-fuel ratio of the inflow of exhaust gas is lean, the NO_x is released from the NO_x absorbent 18. Accordingly, to release the NO_x from the NO_x absorbent 18, it is satisfactory if the concentration of oxygen in the inflow of exhaust gas is lowered. Note, even if the NO_x is released from the NO_x absorbent 18, when the air-fuel ratio of the inflow of exhaust gas is lean, the NO_x is not reduced in the NO_x absorbent 18, and accordingly, in this case, it is necessary to provide a catalyst which can reduce the NO_x downstream of the NO_x absorbent 18 or supply a reducing agent downstream of the NO_x absorbent 18. Of course, it is also possible to reduce the NO_x downstream of the NO_x absorbent 18 in this way, but it is rather preferable that the NO_x be reduced in the NO_x absorbent 18. Accordingly, in the embodiment according to the present invention, when the NO_x should be released from the NO_x absorbent 18, the air-fuel ratio of the inflow of exhaust gas is made the stoichiometric air-

fuel ratio or rich, whereby the NO_x released from the NO_x absorbent 18 is reduced in the NO_x absorbent 18. **[0022]** Figure 6 shows the absorption rate R of the NO_x absorbed into the NO_x absorbent 18 when the air-fuel ratio of the inflow of exhaust gas is lean. Note that, the abscissa T shows the temperature of the NO_x absorbent 18. In actuality, the temperature T of the NO_x absorbent 18 becomes almost equal to the temperature of the exhaust gas flowing into the NO_x absorbent 18. As seen from Fig. 6, when the temperature of the NO_x absorbent 18 becomes lower than about 200°C indicated by T_1 , the oxidation function of NO_x ($2\text{NO} + \text{O}_2 \rightarrow 2\text{NO}_2$) is weakened, and therefore the NO_x absorption rate R is lowered. Moreover, at this time, also the releasing operation of NO_x ($\text{NO}_3^- \rightarrow \text{NO}_2$) is weakened, and therefore even if the air-fuel ratio of the inflow of exhaust gas is made the stoichiometric air-fuel ratio or rich, it becomes impossible to release the NO_x from the NO_x absorbent 18 well. On the other hand, when the temperature T of the NO_x absorbent 18 becomes higher than about 500°C indicated by T_2 , the NO_x absorbed in the NO_x absorbent 18 is decomposed and naturally released from the NO_x absorbent 18, and therefore the NO_x absorption rate is lowered. Accordingly, the NO_x is absorbed well into the NO_x absorbent 18 when the temperature T of the NO_x absorbent 18 is within the predetermined temperature range ($T_1 < T < T_2$).

[0023] As shown in Fig. 3, in the embodiment according to the present invention, the air-fuel ratio of the air-fuel mixture fed into the combustion chamber 3 is made rich at the time of the warm-up operation and at the time of the full load operation, and the air-fuel ratio is made the stoichiometric air-fuel ratio at the time of the acceleration operation, but the lean air-fuel mixture is burned in the combustion chamber 3 in the majority of the operation region other than these. In this case, the air-fuel ratio of the air-fuel mixture burned in the combustion chamber 3 is about more than 18.0. In the embodiment shown in Fig. 1, a lean air-fuel mixture having an air-fuel ratio of from about 20 to 24 is burned. When the air-fuel ratio becomes more than 18.0, even if the three-way catalyst has a reduction property under a lean air-fuel ratio, it cannot sufficiently reduce the NO_x , and accordingly the three-way catalyst cannot be used so as to reduce the NO_x under such a lean air-fuel ratio. Also, as a catalyst which can reduce the NO_x even if the air-fuel ratio is more than 18.0, there is a Cu-zeolite catalyst, but this Cu-zeolite catalyst lacks heat resistance, and therefore the use of this Cu-zeolite catalyst is not preferable in practice. Accordingly, in the end, there is no method of purifying the NO_x when the air-fuel ratio is more than 18.0 other than the method of using the NO_x absorbent 18 which is used in the present invention.

[0024] In the embodiment according to the present invention, as mentioned above, the air-fuel ratio of the air-fuel mixture fed into the combustion chamber 3 is made rich at the time of the full load operation, and that of the air-fuel mixture is made the stoichiometric air-fuel ratio

at the time of the acceleration operation, and therefore NO_x is released from the NO_x absorbent 18 at the time of the full load operation and at the time of the acceleration operation. However, when the frequency of such a full load operation or acceleration operation is low, even if the NO_x is released from the NO_x absorbent 18 only at the time of the full load operation and acceleration operation, the absorption ability of the NO_x by the NO_x absorbent 18 is saturated during the period where the lean air-fuel mixture is burned, and thus the NO_x is no longer absorbed by the NO_x absorbent 18. Accordingly, in the embodiment according to the present invention, when the lean air-fuel mixture is continuously burned, as shown in Fig. 7(A), the air-fuel ratio of the inflow of exhaust gas is periodically made rich, or the air-fuel ratio of the inflow of exhaust gas is periodically made the stoichiometric air-fuel ratio as shown in Fig. 7(B). Note that, in this case, as shown in Fig. 7(C), it is also possible to periodically lower the degree of leanness, but in this case, the NO_x is not reduced in the NO_x absorbent 18, and therefore, as mentioned before, the NO_x must be reduced downstream of the NO_x absorbent 18.

[0025] As shown in Fig. 7(A), looking at the case where the air-fuel ratio of the inflow of exhaust gas is periodically made rich, a time t_2 over which the air-fuel ratio of the inflow of exhaust gas is made rich is much shorter than the time t_1 over which the combustion of the lean air-fuel mixture is carried out. Concretely speaking, while the time t_2 over which the air-fuel ratio of the inflow of exhaust gas is made rich is less than about 10 seconds, the time t_1 over which the combustion of the lean air-fuel mixture is carried out becomes a time of from 10 odd minutes to one hour or more. Namely, in other words, t_2 becomes 50 times or more longer than t_1 . This is true also in the cases shown in Figs. 7(B) and 7(C).

[0026] The releasing operation of the NO_x from the NO_x absorbent 18 is carried out when a constant amount of NO_x is absorbed into the NO_x absorbent 18, for example when NO_x of 50% of the absorption ability of the NO_x absorbent 18 is absorbed. The amount of NO_x absorbed into the NO_x absorbent 18 is proportional to the amount of the exhaust gas discharged from the engine and the NO_x concentration in the exhaust gas. In this case, the amount of the exhaust gas is proportional to the intake air amount, and the NO_x concentration in the exhaust gas is proportional to the engine load, and therefore the amount of NO_x absorbed into the NO_x absorbent 18 is correctly proportional to the amount of intake air and the engine load. Accordingly, the amount of the NO_x absorbed in the NO_x absorbent 18 can be estimated from the cumulative value of the product of the amount of the intake air with the engine load, but in the embodiment according to the present invention, it is simplified and the amount of NO_x absorbed in the NO_x absorbent 18 is estimated from the cumulative value of the engine speed.

[0027] An explanation will be made next of one embodiment of absorption and releasing control of the NO_x absorbent 18 according to the present invention with reference to Fig. 8 and Fig. 9.

[0028] Figure 8 shows an interruption routine executed at predetermined time intervals.

[0029] Referring to Fig. 8, first, it is judged at step 100 whether or not the correction coefficient K with respect to the basic fuel injection time TP is smaller than 1.0, that is, whether or not the lean air-fuel mixture has been burned. When $K < 1.0$, that is, when the lean air-fuel mixture has been burned, the processing routine goes to step 101, at which the result of addition of ΣNE to the current engine speed NE is defined as ΣNE . Accordingly, this ΣNE indicates the cumulative value of the engine speed NE. Subsequently, at step 102, it is judged whether or not the cumulative engine speed ΣNE is larger than the constant value SNE. This constant value SNE shows a cumulative engine speed from which it is estimated that NO_x in an amount of for example 50% of the absorption ability of NO_x is absorbed by the NO_x absorbent 18. When $\Sigma NE \leq SNE$, the processing cycle is completed, and when $\Sigma NE > SNE$, that is, when it is estimated that NO_x in an amount of 50% of the NO_x absorption ability of the NO_x absorbent 18 is absorbed therein, the processing routine goes to step 103. At step 103, it is judged whether or not the exhaust temperature T is lower than a constant value T₁, for example, 200°C. When $T < T_1$, the processing cycle is completed, and when $T \geq T_1$, the processing routine goes to step 104, at which the NO_x releasing flag is set. When the NO_x releasing flag is set, as will be mentioned later, the air-fuel ratio of the air-fuel mixture fed into the engine cylinder is made rich.

[0030] Subsequently, at step 105, the count value C is incremented exactly by "1". Subsequently, at step 106, it is judged whether or not the count value C becomes larger than a constant value C₀, that is, whether or not for example five seconds have elapsed. When $C \leq C_0$, the processing routine is completed, and when C becomes larger than C₀, the processing routine goes to step 107, at which the NO_x releasing flag is reset. When the NO_x releasing flag is reset, as will be mentioned later, the air-fuel ratio of the air-fuel mixture fed into the engine cylinder is switched from rich to lean, and thus the air-fuel ratio of the air-fuel mixture fed into the engine cylinder is made rich for 5 seconds. Subsequently, at step 108, the cumulative engine speed ΣNE and the count value C are brought to zero.

[0031] On the other hand, at step 100, when it is decided that $K \geq 1.0$, that is, when the air-fuel ratio of the air-fuel mixture fed into the engine cylinder is the stoichiometric air-fuel ratio or rich, the processing routine goes to step 109, at which it is judged whether or not the state of $K \geq 1.0$ is continued for a constant time, for example, 10 seconds. When the state of $K \geq 1.0$ is not continued for the predetermined time, the processing cycle is completed, and when the state of $K \geq 1.0$ is con-

tinued for the predetermined time, the processing routine goes to step 110, at which the cumulative engine speed ΣNE is brought to zero.

[0032] Namely, when the time over which the air-fuel ratio of the air-fuel mixture fed into the engine cylinder is made the stoichiometric air-fuel ratio or rich is continued for about 10 seconds, it can be considered that most of the NO_x absorbed in the NO_x absorbent 18 was released, and accordingly in this case, the cumulative engine speed ΣNE is brought to zero at step 110. Also, at step 103, when $T < T_1$, even if the air-fuel ratio of the air-fuel mixture fed into the engine cylinder is made rich, the temperature of the NO_x absorbent 18 is low, and therefore the NO_x is not released from the NO_x absorbent 18. Accordingly, when $T < T_1$, the processing is delayed until T becomes equal to or larger than T₁, and when T becomes equal to or larger than T₁, the air-fuel ratio of the air-fuel mixture fed into the engine cylinder is made rich.

[0033] Figure 9 shows a calculation routine of the fuel injection time TAU. This routine is repeatedly executed.

[0034] Referring to Fig. 9, first, at step 200, a basic fuel injection time TP is calculated from a map indicated in Fig. 2. Subsequently, at step 201, it is judged whether or not the operation state is a state where combustion of the lean air-fuel mixture should be carried out. When it is not an operation state where combustion of the lean air-fuel mixture should be carried out, that is, at the time of the warm-up operation, acceleration operation, or full load operation, the processing routine goes to step 202, at which the correction coefficient K is calculated. At the time of an engine warm-up operation, this correction coefficient K is a function of the engine cooling water temperature and becomes smaller as the engine cooling water temperature becomes higher within a range indicated by $K \geq 1.0$. Also, at the time of the acceleration operation, the correction coefficient K is brought to 1.0, and at the time of the full load operation, the correction coefficient K is made a value larger than 1.0. Subsequently, at step 203, the correction coefficient K is made Kt, and subsequently, at step 204, the fuel injection time TAU (= TP·Kt) is calculated. At this time, the air-fuel ratio of the air-fuel mixture fed into the engine cylinder is made the stoichiometric air-fuel ratio or rich.

[0035] On the other hand, at step 201, when it is judged that the operation state is a state where combustion of the lean air-fuel mixture should be carried out, the processing routine goes to step 205, at which it is judged whether or not the NO_x releasing flag has been set. When the NO_x releasing flag has not been set, the processing routine goes to step 206, at which the correction coefficient K is made for example 0.6, and subsequently, at step 207, the correction coefficient K is changed to Kt, and then the processing routine goes to step 204. Accordingly, at this time, a lean air-fuel mixture is fed into the engine cylinder. On the other hand, when it is decided at step 205 that the NO_x releasing flag was set, the processing routine goes to step 208, at which

the preliminarily determined value KK is changed to Kt, and subsequently the processing routine goes to step 204. This value KK is a value of from about 1.1 to 1.2 with which the air-fuel ratio of the air-fuel mixture fed into the engine cylinder becomes about 12.0 to 13.5. Accordingly, at this time, the rich air-fuel mixture is fed into the engine cylinder, whereby the NO_x absorbed in the NO_x absorbent 18 is released. Note that, at the releasing of NO_x, where the air-fuel mixture is to be made the stoichiometric air-fuel ratio, the value of KK is brought to 1.0.

[0036] Figure 10 indicates another embodiment. In this embodiment, the same constituent elements as those shown in Fig. 1 are indicated by the same reference numerals.

[0037] As shown in Fig. 10, in this embodiment, an air-fuel ratio sensor 22 which can detect the air-fuel ratio over a wide range is disposed in the exhaust manifold 16. This air-fuel ratio sensor 22 generates an output voltage V in accordance with the air-fuel ratio (A/F) as shown in Fig. 11. Accordingly, the air-fuel ratio can be learned from this output voltage V. The output voltage V is input via the AD converter 41 to the input port 35 as shown in Fig. 10.

[0038] In the embodiment indicated in Fig. 1, the value of the correction coefficient K is open loop controlled, and accordingly there is a risk that the lean air-fuel ratio at the combustion of the lean air-fuel mixture and the rich air-fuel ratio at the releasing of NO_x will deviate from the regular air-fuel ratios due to aging. In the embodiment shown in Fig. 10, the air-fuel ratio is subjected to feedback control using the air-fuel ratio sensor 22, whereby these lean air-fuel ratio and rich air-fuel ratio are always brought into coincidence with the regular air-fuel ratios.

[0039] Namely, as shown in Fig. 10, where the air-fuel ratio sensor 22 is used, the fuel injection time TAU is calculated based on the following equation:

$$\text{TAU} = \text{TP} \cdot \text{K} \cdot \text{F} \cdot \text{G}$$

[0040] Here, the basic fuel injection time TP and the correction coefficient K are the same as those used in the embodiment shown in Fig. 1 to Fig. 9, and a feedback correction coefficient F and a learning coefficient G are newly added to this. This feedback correction coefficient F fluctuates so that the air-fuel ratio coincides with the target air-fuel ratio based on the output voltage V of the air-fuel ratio sensor 22, and the learning coefficient G is changed so that a fluctuation around 1.0 occurs. Note that, also in this embodiment, the routine shown in Fig. 8 is used for controlling the NO_x releasing flag.

[0041] Figure 12 shows a routine for calculating the feedback correction coefficient F, which routine is executed by interruption at predetermined time intervals.

[0042] Referring to Fig. 12, first of all, at step 300, it

is judged whether or not the NO_x releasing flag is set. When the NO_x releasing flag is not set, the processing routine goes to step 301, at which a target air-fuel ratio (A/F)₀ corresponding to the correction coefficient K is calculated. Subsequently, at step 302, the current air-fuel ratio (A/F) is calculated from the output voltage V of the air-fuel ratio sensor 22. Subsequently, at step 303, the target air-fuel ratio (A/F)₀ is compared with the present air-fuel ratio (A/F). When (A/F)₀ > (A/F), the processing routine goes to step 304, at which the constant value α is subtracted from the feedback correction coefficient F. As a result, the fuel injection time TAU is decreased, and therefore the air-fuel ratio becomes larger. Contrary to this, when (A/F)₀ ≤ (A/F), the processing routine goes to step 305, at which the constant value α is added to the feedback correction coefficient F. As a result, the fuel injection time TAU is prolonged, and therefore the air-fuel ratio becomes smaller. In this way, the air-fuel ratio (A/F) is maintained at the target air-fuel ratio (A/F)₀.

[0043] Subsequently, at step 306, the average value in the predetermined period of the feedback correction coefficient F is defined as the learning coefficient G. On the other hand, at step 300, when it is decided that the NO_x releasing flag is set, the processing routine goes to step 307, at which the feedback correction coefficient F is fixed to 1.0.

[0044] Figure 13 indicates a calculation routine of the fuel injection time TAU, which routine is repeatedly executed. This routine is the same as the routine shown in Fig. 9 except for step 404.

[0045] Namely, referring to Fig. 13, first of all, at step 400, the basic fuel injection time TP is calculated from the map shown in Fig. 2. Subsequently, at step 401, it is judged whether or not the operation state is a state where combustion of the lean air-fuel mixture should be carried out. When the operation state is not a state where combustion of the lean air-fuel mixture should be carried out, that is, at the time of the warm-up operation, acceleration operation, or full load operation, the processing routine goes to step 402, at which the correction coefficient K is calculated. Subsequently, at step 403, the correction coefficient K is brought to Kt, and subsequently, at step 404, the fuel injection time TAU (= TP·Kt·F·G) is calculated. At this time, the air-fuel ratio of the air-fuel mixture fed into the engine cylinder is made to have the stoichiometric air-fuel ratio or rich air-fuel ratio.

[0046] On the other hand, when it is judged at step 401 that the operation state is a state where combustion of the lean air-fuel mixture should be carried out, the processing routine goes to step 405, at which it is judged whether or not the NO_x releasing flag is set. When the NO_x releasing flag is not set, the processing routine goes to step 406, at which the correction coefficient K is changed to, for example, 0.6, and subsequently, after the correction coefficient K is brought to Kt at step 407, the processing routine goes to step 404. Accordingly, at

this time, the lean air-fuel mixture is fed into the engine cylinder. On the other hand, when it is decided at step 405 that the NO_x releasing flag was set, the processing routine goes to step 408, at which the preliminarily determined value KK is set to Kt, and subsequently, the processing routine goes to step 404. This value KK is a value of from about 1.1 to 1.2. Accordingly, at this time, a rich air-fuel mixture is fed into the engine cylinder, whereby the NO_x absorbed in the NO_x absorbent 18 is released.

[0047] As mentioned before, the learning coefficient G expresses an average value of the feedback correction coefficient F in the predetermined period. This feedback correction coefficient F originally fluctuates around 1.0. For example, when assuming that a deposit builds up in the nozzle port of the fuel injector 11, the feedback correction coefficient F becomes larger than 1.0 so as to maintain the air-fuel ratio (A/F) at the target air-fuel ratio (A/F)₀. In this way, when the feedback correction coefficient F becomes larger than 1.0, the learning coefficient G becomes larger along with this, and thus the feedback correction coefficient F always fluctuates around 1.0. Accordingly, in this case, when the feedback correction coefficient F is fixed to 1.0, the air-fuel ratio (A/F) coincides with the target air-fuel ratio (A/F)₀ corresponding to the correction coefficient K. In the embodiment shown in Fig. 10, as shown in Fig. 12, when the NO_x releasing flag is set, the feedback correction coefficient F is fixed to 1.0. Accordingly, at this time, the air-fuel ratio of the air-fuel mixture fed into the engine cylinder is brought into a correct coincidence with the air-fuel ratio corresponding to KK.

[0048] Figure 14 shows still another embodiment. In this embodiment, an output side of the casing 19 is connected via the exhaust pipe 23 with a catalytic converter 25 including a three-way catalyst 24 therein. This three-way catalyst 24 exhibits a high purification efficiency with respect to the CO, HC, and NO_x when the air-fuel ratio is maintained at approximately the stoichiometric air-fuel ratio as is well known, but this three-way catalyst 24 has a high purification efficiency with respect to the NO_x even when the air-fuel ratio has become rich to a certain extent. In the embodiment shown in Fig. 14, a three-way catalyst 24 is provided downstream of the NO_x absorbent 18 so as to purify the NO_x by utilizing this characteristic.

[0049] Namely, as mentioned before, when the air-fuel ratio of the air-fuel mixture fed into the engine cylinder is made rich so as to release the NO_x from the NO_x absorbent 18, the NO_x absorbed in the NO_x absorbent 18 is abruptly released from the NO_x absorbent 18. At this time, although the NO_x is reduced at the releasing, there is a possibility that all the NO_x is not reduced. However, when the three-way catalyst 24 is disposed downstream of the NO_x absorbent 18, the NO_x which was not reduced at the releasing is reduced by the three-way catalyst 24. Accordingly, by disposing the three-way catalyst 24 downstream of the NO_x absorbent 18, the NO_x

purification performance can be further improved.

[0050] Figure 15 shows more still another embodiment. In this embodiment, still another catalytic converter 27 including a three-way catalyst 26 is disposed between the exhaust manifold 16 and the exhaust pipe 17. In this way, when the three-way catalyst 26 is disposed near the exhaust port 8, the three-way catalyst 26 is in contact with exhaust gas having a higher temperature in comparison with the NO_x absorbent 18 and the three-way catalyst 24, and therefore the three-way catalyst 26 abruptly rises in its temperature after a start of the engine in comparison with the NO_x absorbent 18 and the three-way catalyst 24. Accordingly, when providing such a three-way catalyst 26, it becomes possible to purify the unburnt HC and CO generated in a large amount during the engine warm-up operation by the three-way catalyst 26 from an early time after the start of the engine.

[0051] In the embodiments mentioned heretofore, as the NO_x absorbent, use is made of an NO_x absorbent 18 in which at least one substance selected from alkali metals, alkali earth metals, rare earth metals, and precious metals is carried on the alumina. However, it is possible to use a composite oxide of an alkali earth metal with copper, that is, a Ba-Cu-O system NO_x absorbent, instead of the use of such an NO_x absorbent 18. As such a composite oxide of the alkali earth metal with copper, use can be made of, for example, MnO₂·BaCuO₂. In this case, platinum Pt or cerium Ce can be added.

[0052] In this MnO₂·BaCuO₂ system NO_x absorbent, the copper Cu performs the same catalytic function as that of the platinum Pt of the NO_x absorbent 18 mentioned heretofore. When the air-fuel ratio is lean, the NO_x is oxidized by the copper Cu ($2\text{NO} + \text{O}_2 \rightarrow 2\text{NO}_2$) and diffused in the absorbent in the form of the nitric acid ions NO₃⁻.

[0053] On the other hand, when the air-fuel ratio is made rich, similarly the NO_x is released from the absorbent, and this NO_x is reduced by the catalytic function of the copper Cu. However, the NO_x reduction force of the copper Cu is weaker in comparison with the NO_x reduction force of the platinum Pt, and accordingly where the Ba-Cu-O system absorbent is used, an amount of NO_x which is not reduced at the releasing of NO_x is slightly increased in comparison with the NO_x absorbent 18 mentioned heretofore. Accordingly, where the Ba-Cu-O system absorbent is used, as shown in Fig. 14 and Fig. 15, preferably the three-way catalyst 24 is disposed downstream of the absorbent.

[0054] Figure 16 and Figure 19 show a case where the present invention is applied to a diesel engine. Note that, in Fig. 16 and Fig. 19, the same constituent elements as those in Fig. 1 are shown by the same reference numerals.

[0055] In the diesel engine, usually, in all operation states, combustion is carried out in a state where the excessive air ratio is more than 1.0, that is, the average

air-fuel ratio of the air-fuel mixture in the combustion chamber 3 is lean. Accordingly, the NO_x discharged at this time is absorbed into the NO_x absorbent 18. On the other hand, when the NO_x should be released from the NO_x absorbent 18, the air-fuel ratio of the inflow of exhaust gas to the NO_x absorbent 18 is made rich. In this case, in the embodiment shown in Fig. 16, the average air-fuel ratio of the air-fuel mixture in the combustion chamber 3 is made rich, whereby the air-fuel ratio of the inflow of exhaust gas to the NO_x absorbent 18 is made rich. In the embodiment shown in Fig. 19, the average air-fuel ratio of the air-fuel mixture in the combustion chamber 3 is made lean, and the hydrocarbon is fed into the exhaust passage of engine upstream of the NO_x absorbent 18, whereby the air-fuel ratio of the inflow of exhaust gas to the NO_x absorbent 18 is made rich.

[0056] Referring to Fig. 16, in this embodiment, a load sensor 51 generating an output voltage proportional to the amount of depression of the accelerator pedal 50 is provided, and the output voltage of this load sensor 51 is input via the AD converter 52 to the input port 35. Also, in this embodiment, a throttle valve 53 is disposed in the intake duct 12, which throttle valve 53 is connected to a diaphragm 55 of a vacuum diaphragm device 54. A diaphragm vacuum chamber 56 of the vacuum diaphragm device 54 is selectively connected with the atmosphere or a vacuum tank 58 via an electromagnetic switching valve 57, while the output port 36 of the electronic control unit 30 is connected to the electromagnetic switching valve 57 via a driving circuit 59. For the electromagnetic switching valve 57, a ratio between a time for which the diaphragm vacuum chamber 56 is communicated with the atmosphere and a time for which it is communicated with the vacuum tank 58, that is, the duty ratio DUTY, is controlled. As this duty ratio DUTY becomes larger, the opening degree of the throttle valve 53 becomes smaller.

[0057] In this embodiment, when the NO_x should be released from the NO_x absorbent 18, the amount of injection from the fuel injector 11 is increased only by a constant amount ΔQ with respect to the requested injection amount with which the best combustion is obtained, and simultaneously the throttle valve 53 is opened to the predetermined opening degree so that the average air-fuel ratio of the air-fuel mixture in the combustion chamber 3 becomes rich. Namely, when the amount of injection from the fuel injector 11 is increased by only the constant amount ΔQ with respect to the requested injection amount with which the best combustion is obtained, this increased amount worth ΔQ is not burned well and is discharged to the interior of the exhaust port 8 in the form of unburnt HC and CO. Also, at this time, the amount of air fed into the combustion chamber 3 is decreased by the opening operation of the throttle valve 53, and therefore the air-fuel ratio of the exhaust gas discharged to the interior of the exhaust port 8 become rich. Accordingly, the air-fuel ratio of the inflow of exhaust gas flowing into the NO_x absorbent 18

becomes rich, and thus the NO_x is released from the NO_x absorbent 18. The amount ΔQ of increase of fuel and amount of opening of the throttle valve 53 when the NO_x should be released from the NO_x absorbent 18 are preliminarily found by experiment.

[0058] Figure 17 shows an interruption routine executed at predetermined time intervals for executing the above-mentioned control.

[0059] Referring to Fig. 17, first of all, at step 500, a result obtained by adding ΣNE to the present engine speed NE is defined as ΣNE . Accordingly, this ΣNE indicates the cumulative value of the engine speed NE. Subsequently, at step 501, it is judged whether or not the cumulative engine speed ΣNE is larger than the predetermined value SNE. This predetermined value SNE indicates the cumulative engine speed from which it is estimated that the NO_x in an amount of for example 50% of the NO_x absorption ability of the NO_x absorbent 18 is absorbed therein. When $\Sigma NE \leq SNE$, the processing cycle is completed, and when $\Sigma NE > SNE$, that is, when it is estimated that the NO_x in an amount of 50% of the NO_x absorption ability of the NO_x absorbent 18 is absorbed therein, the processing routine goes to step 502. At step 502, it is judged whether or not the exhaust temperature T is lower than the predetermined value T₁, for example, 200°C. When $T < T_1$, the processing cycle is completed, and when $T \geq T_1$, the processing routine goes to step 503, at which the NO_x releasing flag is set. When the NO_x releasing flag is set, as will be mentioned later, the fuel injection amount is increased, and the throttle valve 53 is opened to the constant opening degree.

[0060] Subsequently, at step 504, the count value C is incremented exactly by "1". Subsequently, at step 505, it is judged whether or not the count value C becomes larger than the predetermined value C₀, that is, whether or not for example 5 seconds elapsed. When $C \leq C_0$, the processing routine is completed, and when C becomes larger than C₀, the processing routine goes to step 506, at which the NO_x releasing flag is reset. When the NO_x releasing flag is reset, as will be mentioned later, the increasing operation of the fuel injection amount is stopped, and the throttle valve 53 is fully opened. Accordingly, the air-fuel ratio of the exhaust gas flowing into the NO_x absorbent 18 is made rich for 5 seconds. Subsequently, at step 507, the cumulative engine speed ΣNE and the count value C are brought to zero.

[0061] Figure 18 shows a main routine.

[0062] Referring to Fig. 18, first of all, at step 600, the fuel injection amount Q is calculated based on the output signals from the engine speed sensor 21 and the load sensor 51. Subsequently, it is judged at step 601 whether or not the NO_x releasing flag has been set. When the NO_x releasing flag has not been set, the processing routine goes to step 607, at which the duty ratio DUTY is brought to zero, and subsequently the processing routine goes to step 605, at which the control of the throttle valve 53 is carried out. At this time, the duty ratio DUTY

is zero, and therefore the throttle valve 53 is retained at the fully open state. Subsequently, at step 606, the fuel injection processing is carried out, and the injection amount at this time becomes the injection amount Q calculated at step 600.

[0063] On the other hand, when it is decided at step 601 that the NO_x releasing flag has been set, the processing routine goes to step 602, at which the injection amount increase value ΔQ is calculated. Subsequently, at step 603, the increase value ΔQ is added to the injection amount Q, to obtain a new injection amount Q. Subsequently, at step 604, the duty ratio DUTY is calculated. Subsequently, at step 605, the throttle valve 53 is opened to the opening degree determined by the duty ratio DUTY, and subsequently, at step 606, the fuel is injected from the fuel injector 11 according to the injection amount Q calculated at step 603.

[0064] In the embodiment shown in Fig. 19, a reducing agent supply valve 60 is disposed in the exhaust pipe 17, which this reducing agent supply valve 60 is connected with a reducing agent tank 62 via a supply pump 61. The output port 36 of the electronic control unit 30 is connected to the reducing agent supply valve 60 and the supply pump 61 via the driving circuits 63 and 64, respectively. In the reducing agent tank 62, a hydrocarbon such as gasoline, isooctane, hexane, heptane, light oil, kerosine, or the like or a hydrocarbon such as butane, propane, or the like which can be stored in the state of a liquid is filled.

[0065] In this embodiment, usually the air-fuel mixture in the combustion chamber 3 is burned under an excess air state, that is, in a state where the average air-fuel ratio is lean. At this time, the NO_x discharged from the engine is absorbed into the NO_x absorbent 18. When the NO_x should be released from the NO_x absorbent 18, the supply pump 61 is driven and, at the same time, the reducing agent supply valve 60 is opened, whereby the hydrocarbon filled in the reducing agent tank 62 is supplied from the reducing agent supply valve 60 to the exhaust pipe 17 for a predetermined time, for example, about 5 seconds to 20 seconds. The amount of supply of the hydrocarbon at this time is determined so that the air-fuel ratio of the inflow of exhaust gas flowing into the NO_x absorbent 18 becomes rich. Accordingly, at this time, the NO_x is released from the NO_x absorbent 18.

[0066] Figure 20 shows a routine for executing the NO_x releasing processing, which routine is executed by interruption at every predetermined time interval.

[0067] Referring to Fig. 20, first of all, at step 700, a result obtained by adding ΣNE to the present engine speed NE is defined as ΣNE . Accordingly, this ΣNE indicates the cumulative value of the engine speed NE. Subsequently, at step 701, it is judged whether or not the cumulative engine speed ΣNE is larger than the predetermined value SNE. This predetermined value SNE indicates a cumulative engine speed from which it is estimated that the NO_x in an amount of, for example, 50% of the NO_x absorption ability of the NO_x absorbent 18 is

absorbed therein. When $\Sigma NE \leq SNE$, the processing cycle is completed, and when $\Sigma NE > SNE$, that is, when it is estimated that the NO_x in an amount of 50% of the NO_x absorption ability of the NO_x absorbent 18 is absorbed therein, the processing routine goes to step 702. At step 702, it is judged whether or not the exhaust temperature T is lower than the predetermined value T₁, for example, 200°C. When $T < T_1$, the processing cycle is completed, and when $T \geq T_1$, the processing routine goes to step 703, at which the supply pump 61 is driven for a predetermined time, for example, about 5 seconds to 20 seconds. Subsequently, at step 704, the reducing agent supply valve 60 is opened for a predetermined time, for example, about 5 seconds to 20 seconds, and subsequently, at step 705, the cumulative engine speed ΣNE is brought to zero.

[0068] As mentioned before, when the temperature is lowered, the NO_x absorbent 18 becomes not able to absorb the NO_x. However, in all of the embodiments mentioned heretofore, the exhaust gas is always flows into the NO_x absorbent 18 during the operation of the engine, and therefore the NO_x absorbent 18 is retained at a relatively high temperature. Accordingly, it becomes possible to cause the NO_x generated during the engine operation to be absorbed in the NO_x absorbent 18 well.

LIST OF REFERENCE NUMERALS

[0069]

3	combustion chamber;
5	intake valve;
7	exhaust valve;
17, 23	exhaust pipes;
18	NO _x absorbent;
20	temperature sensor; and
24, 26	three-way catalysts.

40 Claims

Claims for the following Contracting States : DE, FR, GB

1. An exhaust purification device of a lean burn internal combustion engine (1) comprising an NO_x absorbent (18) disposed in an exhaust passage (17) of said engine (1), wherein the exhaust gas continuously flows into the NO_x absorbent (18) during an operation of said engine (1), wherein a lean air-fuel mixture is continuously burned and said absorbent (18) comprises a catalyst, and absorbs NO_x when the exhaust gas is lean and releases said absorbed NO_x when the oxygen concentration of the exhaust gas is lowered, wherein release of absorbed NO_x takes place when the air-fuel ratio of the inflowing exhaust gas is rich and when the air-fuel ratio is sto-

- ichiometric, wherein the air-fuel ratio of the exhaust gas is made rich or stoichiometric when a constant amount of NO_x is absorbed in the NO_x absorbent (18), to release the absorbed NO_x from the NO_x absorbent (18), so that, when the exhaust gas is rich or the stoichiometric air-fuel ratio, unburned HC and CO in the exhaust gas react with the released NO_x to thereby reduce the NO_x , wherein the NO_x -release processing is not carried out until the temperature (T) of said NO_x absorbent (18) becomes equal to or larger than a predetermined temperature (T1).
2. An exhaust purification device of an internal combustion engine according to claim 1, wherein a period for which the air-fuel ratio of the exhaust gas flowing into the No_x absorbent is made lean and the No_x is absorbed in the No_x absorbent is 50 times or more longer than the period for which the oxygen concentration in the exhaust gas flowing into the No_x absorbent is lowered so as to release the No_x from the No_x absorbent.
 3. An exhaust purification device of an internal combustion engine according to claim 1, wherein the air-fuel ratio of the exhaust gas flowing into the NO_x is absorbed into the No_x absorbent.
 4. An exhaust purification device of an internal combustion engine according to claim 1, wherein the No_x absorbent contains at least one substance selected from alkali metals comprising potassium, sodium, lithium, or cesium, alkali earth metals comprising barium or calcium, rare earth metals comprising lanthanum or yttrium and contains platinum.
 5. An exhaust purification device of an internal combustion engine according to claim 1, wherein the No_x absorbent comprises a composite oxide of barium and copper.
 6. An exhaust purification device of an internal combustion engine according to claim 1, wherein air-fuel ratio control means is provided for controlling the air-fuel ratio of the air-fuel mixture formed in an engine combustion chamber, and the absorption of No_x absorbent and the releasing of No_x from the No_x absorbent are controlled by controlling the air-fuel ratio of the air-fuel mixture formed in the engine combustion chamber by said air-fuel ratio control means.
 7. An exhaust purification device of an internal combustion engine according to claim 6, wherein said air-fuel ratio control means is adapted to make the air-fuel ratio of the air-fuel mixture formed in the combustion chamber lean when the No_x should be absorbed into the No_x absorbent and to make the air-fuel ratio of the air-fuel mixture formed in the combustion chamber the stoichiometric air-fuel ratio or rich when the No_x should be released from the No_x absorbent.
 8. An exhaust purification device of an internal combustion engine according to claim 7, wherein the internal combustion engine comprises a gasoline engine and said air-fuel ratio control means control the absorption of No_x into the No_x absorbent and the releasing of No_x absorbent by controlling the fuel amount supplied to the engine.
 9. An exhaust purification device of an internal combustion engine according to claim 8, wherein said air-fuel ratio control means maintains the air-fuel ratio of the air-fuel mixture formed in the combustion chamber at almost a constant lean air-fuel ratio of more than 18.0 when the NO_x should be absorbed into the NO_x absorbent.
 10. An exhaust purification device of an internal combustion engine according to claim 8, further comprising memory means for storing in advance the amount of fuel determined in accordance with the operation state of the engine, said air-fuel ratio control means is adapted to determine the amount of fuel supplied to the engine based on the fuel amount stored in said memory means.
 11. An exhaust purification device of an internal combustion engine according to claim 8, further comprising memory means for storing in advance the basic fuel amount determined in accordance with the operation state of the engine and an air-fuel ratio sensor which is provided in the exhaust passage of the engine for detecting the air-fuel ratio of the exhaust gas flowing in the exhaust passage, said air-fuel ratio control means is adapted to correct the basic fuel amount so that the air-fuel ratio of the exhaust gas becomes the target air-fuel ratio by a feedback correction coefficient varied in accordance with the output signal of said air-fuel ratio sensor.
 12. An exhaust purification device of an internal engine according to claim 11, wherein said air-fuel ratio control means is adapted to correct the basic fuel amount so that the air-fuel ratio of the exhaust gas becomes the target air-fuel ratio by the feedback correction coefficient when the No_x should be absorbed into the No_x absorbent and, at the same time, to correct said feedback correction coefficient by a learning coefficient so that said feedback correction coefficient fluctuates around a reference value, and said air-fuel control means is adapted to fix the feedback correction value to said reference value when the No_x should be released from the No_x

absorbent and, at the same time, to determine the amount of fuel to be supplied to the engine based on the learning coefficient and the basic fuel amount.

13. An exhaust purification device of an internal combustion engine according to claim 7, wherein the internal combustion engine comprises a diesel engine equipped with a fuel injector for injecting the fuel into the combustion chamber and a throttle valve disposed in the intake passage of the engine; and said air-fuel ratio control means is adapted to control the absorption of No_x into the No_x absorbent and the releasing of No_x from the No_x absorbent by controlling the amount of injection from the fuel injector and the opening degree of throttle valve.

14. An exhaust purification device of an internal combustion engine according to claim 13, wherein said air-fuel ratio control means is adapted to increase the injection amount and to decrease the throttle valve opening degree when the No_x should be released from the No_x absorbent.

15. An exhaust purification device of an internal combustion engine according to claim 1, further comprising air-fuel ratio control means for controlling the air-fuel ratio of the exhaust gas discharged from the engine combustion chamber and flowing into the No_x absorbent in the exhaust passage of the engine, and the absorption of No_x into the No_x absorbent and the releasing of No_x from the No_x absorbent are controllable by controlling the air-fuel ratio of the exhaust gas flowing into the No_x absorbent by said ratio control means.

16. An exhaust purification device of an internal combustion engine according to claim 15, wherein said air-fuel ratio control means is adapted to make the air-fuel ratio of the exhaust gas flowing into the No_x absorbent lean when the No_x should be absorbed into the No_x absorbent, while to make the air-fuel ratio of the exhaust gas flowing into the No_x absorbent the stoichiometric air-fuel ratio or rich when the No_x should be released from the No_x absorbent.

17. An exhaust purification device of an internal combustion engine according to claim 16, wherein said air-fuel ratio control means is adapted to supply a reducing agent to the interior of the exhaust passage of the engine when the No_x should be released from the No_x absorbent.

18. An exhaust purification device of an internal combustion engine according to claim 17, wherein said reducing agent is made of a hydrocarbon.

19. An exhaust purification device of an internal com-

bustion engine according to claim 18, wherein said hydrocarbon comprises at least one member selected from gasoline, isooctane, hexane, heptane, butane, propane, light oil, and kerosine.

20. An exhaust purification device of an internal combustion engine according to claim 1, further comprising No_x releasing control means which is suitable to lower the oxygen concentration in the exhaust gas flowing into the No_x absorbent only for a second set-up period preliminarily determined so as to release the No_x from the No_x absorbent when the period for which the air-fuel ratio of the exhaust gas flowing into the No_x absorbent is made lean and the No_x is absorbed into the No_x absorbent exceeds a preliminarily determined first set-up period.

21. An exhaust purification device of an internal combustion engine according to claim 20, wherein said No_x releasing control means is adapted to make the air-fuel ratio of the exhaust gas flowing into the No_x absorbent the stoichiometric air-fuel ratio or rich when the No_x should be released from the No_x absorbent.

22. An exhaust purification device of an internal combustion engine according to claim 20, wherein the said No_x releasing control means is provided with No_x amount estimation means for estimating the amount of No_x absorbed into the No_x absorbent, and said No_x releasing control means is adapted to decide that said first set-up period has lapsed when the amount of No_x estimated by the No_x amount estimation means exceeds a preliminarily determined set-up amount.

23. An exhaust purification device of an internal combustion engine according to claim 22, wherein said No_x amount estimation means is adapted to decide that the amount of No_x absorbed in the No_x absorbent exceeds said set-up amount when a cumulative value of an engine speed exceeds a preliminarily determined set-up value.

24. An exhaust purification device of an internal combustion engine according to claim 22, wherein said No_x amount estimation means is adapted to decide that substantially all of the No_x absorbed in the No_x absorbent was released when the air-fuel ratio of the air-fuel mixture formed in the engine combustion chamber is maintained at the stoichiometric air-fuel ratio or is rich for a predetermined time or more.

25. An exhaust purification device of an internal combustion engine according to claim 20, wherein said second set-up period is substantially less than 20 seconds.

26. An exhaust purification device of an internal combustion engine according to claim 20, wherein said NO_x releasing control means is provided with a temperature sensor for detecting a temperature of the exhaust gas flowing into the NO_x absorbent, and said NO_x releasing control means is provided with prohibition means which prohibits the lowering of the oxygen concentration in the exhaust gas flowing into the NO_x absorbent even if the period for which the NO_x is absorbed into the NO_x absorbent exceeds said first set-up period when the temperature of the exhaust gas flowing into the NO_x absorbent becomes lower than a limit temperature at which the NO_x can be absorbed by the NO_x absorbent.

27. An exhaust purification device of an internal combustion engine according to claim 26, wherein said NO_x releasing control means is adapted to immediately lower the oxygen concentration in the exhaust gas flowing into the NO_x absorbent when the temperature of the exhaust gas flowing into the NO_x absorbent becomes higher than said limit temperature after the oxygen concentration in the exhaust gas flowing into the NO_x absorbent is lowered by said prohibition means.

28. An exhaust purification device of an internal combustion engine according to claim 1, wherein a further catalyst which can reduce at least the NO_x is disposed in the exhaust passage of the engine downstream of the NO_x absorbent.

29. An exhaust purification device of an internal combustion engine according to claim 28, wherein said catalyst comprises a three-way catalyst.

30. An exhaust purification device of an internal combustion engine according to claim 1, wherein a further catalyst which can purify the unburnt HC and CO is disposed in the exhaust passage of the engine upstream of the NO_x absorbent.

31. An exhaust purification device of an internal combustion engine according to claim 30, wherein said catalyst comprises a three-way catalyst.

Claims for the following Contracting States : ES, IT, SE

1. An exhaust purification device of a lean burn internal combustion engine (1) comprising an NO_x absorbent (18) disposed in an exhaust passage (17) of said engine (1), wherein the exhaust gas continuously flows into the NO_x absorbent (18) during an operation of said engine (1), wherein said absorbent (18) comprises a catalyst, and absorbs NO_x when the exhaust gas is lean and releases said ab-

sorbed NO_x when the oxygen concentration of the exhaust gas is lowered, so that, when the exhaust gas is rich or the stoichiometric air-fuel ratio, unburned HC and CO in the exhaust gas react with the released NO_x to thereby reduce the NO_x .

2. An exhaust purification device of an internal combustion engine according to claim 1, wherein a period for which the air-fuel ratio of the exhaust gas flowing into the NO_x absorbent is made lean and the NO_x is absorbed in the NO_x absorbent is 50 times or more longer than the period for which the oxygen concentration in the exhaust gas flowing into the NO_x absorbent is lowered so as to release the NO_x from the NO_x absorbent.

3. An exhaust purification device of an internal combustion engine according to claim 1, wherein the air-fuel ratio of the exhaust gas flowing into the NO_x is absorbed into the NO_x absorbent.

4. An exhaust purification device of an internal combustion engine according to claim 1, wherein the NO_x absorbent contains at least one substance selected from alkali metals comprising potassium, sodium, lithium, or cesium, alkali earth metals comprising barium or calcium, rare earth metals comprising lanthanum or yttrium and contains platinum.

5. An exhaust purification device of an internal combustion engine according to claim 1, wherein the NO_x absorbent comprises a composite oxide of barium and copper.

6. An exhaust purification device of an internal combustion engine according to claim 1, wherein air-fuel ratio control means is provided for controlling the air-fuel ratio of the air-fuel mixture formed in an engine combustion chamber, and the absorption of NO_x absorbent and the releasing of NO_x from the NO_x absorbent are controlled by controlling the air-fuel ratio of the air-fuel mixture formed in the engine combustion chamber by said air-fuel ratio control means.

7. An exhaust purification device of an internal combustion engine according to claim 6, wherein said air-fuel ratio control means is adapted to make the air-fuel ratio of the air-fuel mixture formed in the combustion chamber lean when the NO_x should be absorbed into the NO_x absorbent and to make the air-fuel ratio of the air-fuel mixture formed in the combustion chamber the stoichiometric air-fuel ratio or rich when the NO_x should be released from the NO_x absorbent.

8. An exhaust purification device of an internal combustion engine according to claim 7, wherein the in-

ternal combustion engine comprises a gasoline engine and said air-fuel ratio control means control the absorption of NO_x into the NO_x absorbent and the releasing of NO_x absorbent by controlling the fuel amount supplied to the engine.

9. An exhaust purification device of an internal combustion engine according to claim 8, wherein said air-fuel ratio control means maintains the air-fuel ratio of the air-fuel mixture formed in the combustion chamber at almost a constant lean air-fuel ration of more than 18.0 when the NO_x should be absorbed into the NO_x absorbent.
10. An exhaust purification device of an internal combustion engine according to claim 8, further comprising memory means for storing in advance the amount of fuel determined in accordance with the operation state of the engine, said air-fuel ratio control means is adapted to determine the amount of fuel supplied to the engine based on the fuel amount stored in said memory means.
11. An exhaust purification device of an internal combustion engine according to claim 8, further comprising memory means for storing in advance the basic fuel amount determined in accordance with the operation state of the engine and an air-fuel ratio sensor which is provided in the exhaust passage of the engine for detecting the air-fuel ratio of the exhaust gas flowing in the exhaust passage, said air-fuel ratio control means is adapted to correct the basic fuel amount so that the air-fuel ratio of the exhaust gas becomes the target air-fuel ratio by a feedback correction coefficient varied in accordance with the output signal of said air-fuel ratio sensor.
12. An exhaust purification device of an internal engine according to claim 11, wherein said air-fuel ratio control means is adapted to correct the basic fuel amount so that the air-fuel ratio of the exhaust gas becomes the target air-fuel ratio by the feedback correction coefficient when the NO_x should be absorbed into the NO_x absorbent and, at the same time, to correct said feedback correction coefficient by a learning coefficient so that said feedback correction coefficient fluctuates around a reference value, and said air-fuel control means is adapted to fix the feedback correction value to said reference value when the NO_x should be released from the NO_x absorbent and, at the same time, to determine the amount of fuel to be supplied to the engine based on the learning coefficient and the basic fuel amount.
13. An exhaust purification device of an internal combustion engine according to claim 7, wherein the in-

ternal combustion engine comprises a diesel engine equipped with a fuel injector for injecting the fuel into the combustion chamber and a throttle valve disposed in the intake passage of the engine; and said air-fuel ratio control means is adapted to control the absorption of NO_x into the NO_x absorbent and the releasing of NO_x from the NO_x absorbent by controlling the amount of injection from the fuel injector and the opening degree of throttle valve.

14. An exhaust purification device of an internal combustion engine according to claim 13, wherein said air-fuel ratio control means is adapted to increase the injection amount and to decrease the throttle valve opening degree when the NO_x should be released from the NO_x absorbent.
15. An exhaust purification device of an internal combustion engine according to claim 1, further comprising air-fuel ratio control means for controlling the air-fuel ratio of the exhaust gas discharged from the engine combustion chamber and flowing into the NO_x absorbent in the exhaust passage of the engine, and the absorption of NO_x into the NO_x absorbent and the releasing of NO_x from the NO_x absorbent are controllable by controlling the air-fuel ratio of the exhaust gas flowing into the NO_x absorbent by said ratio control means.
16. An exhaust purification device of an internal combustion engine according to claim 15, wherein said air-fuel ratio control means is adapted to make the air-fuel ratio of the exhaust gas flowing into the NO_x absorbent lean when the NO_x should be absorbed into the NO_x absorbent, while to make the air-fuel ratio of the exhaust gas flowing into the NO_x absorbent the stoichiometric air-fuel ratio or rich when the NO_x should be released from the NO_x absorbent.
17. An exhaust purification device of an internal combustion engine according to claim 16, wherein said air-fuel ratio control means is adapted to supply a reducing agent to the interior of the exhaust passage of the engine when the NO_x should be released from the NO_x absorbent.
18. An exhaust purification device of an internal combustion engine according to claim 17, wherein said reducing agent is made of a hydrocarbon.
19. An exhaust purification device of an internal combustion engine according to claim 18, wherein said hydrocarbon comprises at least one member selected from gasoline, isooctane, hexane, heptane, butane, propane, light oil, and kerosine.
20. An exhaust purification device of an internal combustion engine according to claim 1, further com-

prising No_x releasing control means which is suitable to lower the oxygen concentration in the exhaust gas flowing into the No_x absorbent only for a second set-up period preliminarily determined so as to re-
 5 release the No_x from the No_x absorbent when the period for which the air-fuel ratio of the exhaust gas flowing into the No_x absorbent is made lean and the No_x is absorbed into the No_x absorbent exceeds a preliminarily determined first set-up period.

21. An exhaust purification device of an internal combustion engine according to claim 20, wherein said No_x releasing control means is adapted to make the air-fuel ratio of the exhaust gas flowing into the No_x absorbent the stoichiometric air-fuel ratio or rich when the No_x should be released from the No_x absorbent.
22. An exhaust purification device of an internal combustion engine according to claim 20, wherein the said No_x releasing control means is provided with No_x amount estimation means for estimating the amount of No_x absorbed into the No_x absorbent, and said No_x releasing control means is adapted to decide that said first set-up period has lapsed when the amount of No_x estimated by the No_x amount estimation means exceeds a preliminarily determined set-up amount.
23. An exhaust purification device of an internal combustion engine according to claim 22, wherein said No_x amount estimation means is adapted to decide that the amount of No_x absorbed in the No_x absorbent exceeds said set-up amount when a cumulative value of an engine speed exceeds a preliminarily determined set-up value.
24. An exhaust purification device of an internal combustion engine according to claim 22, wherein said No_x amount estimation means is adapted to decide that substantially all of the No_x absorbed in the No_x absorbent was released when the air-fuel ratio of the air-fuel mixture formed in the engine combustion chamber is maintained at the stoichiometric air-fuel ratio or is rich for a predetermined time or more.
25. An exhaust purification device of an internal combustion engine according to claim 20, wherein said second set-up period is substantially less than 20 seconds.
26. An exhaust purification device of an internal combustion engine according to claim 20, wherein said No_x releasing control means is provided with a temperature sensor for detecting a temperature of the exhaust gas flowing into the No_x absorbent, and said No_x releasing control means is provided with prohibition means which prohibits the lowering of

the oxygen concentration in the exhaust gas flowing into the No_x absorbent even if the period for which the No_x is absorbed into the No_x absorbent exceeds said first set-up period when the temperature of the exhaust gas flowing into the No_x absorbent becomes lower than a limit temperature at which the No_x can be absorbed by the No_x absorbent.

27. An exhaust purification device of an internal combustion engine according to claim 26, wherein said No_x releasing control means is adapted to immediately lower the oxygen concentration in the exhaust gas flowing into the No_x absorbent when the temperature of the exhaust gas flowing into the No_x absorbent becomes higher than said limit temperature after the oxygen concentration in the exhaust gas flowing into the No_x absorbent is lowered by said prohibition means.
28. An exhaust purification device of an internal combustion engine according to claim 1, wherein a further catalyst which can reduce at least the No_x is disposed in the exhaust passage of the engine downstream of the No_x absorbent.
29. An exhaust purification device of an internal combustion engine according to claim 28, wherein said catalyst comprises a three-way catalyst.
30. An exhaust purification device of an internal combustion engine according to claim 1, wherein a further catalyst which can purify the unburnt HC and CO is disposed in the exhaust passage of the engine upstream of the No_x absorbent.
31. An exhaust purification device of an internal combustion engine according to claim 30, wherein said catalyst comprises a three-way catalyst.

Patentansprüche

Patentansprüche für folgende Vertragsstaaten : DE, FR, GB

1. Eine Abgasreinigungsvorrichtung einer Brennkraftmaschine (1) umfasst ein in einem Abgaskanal (17) der genannten Maschine (1) angeordnetes NO_x -Absorbens (18), wobei das Abgas während eines Betriebs der genannten Maschine (1) kontinuierlich in das NO_x -Absorbens (18) strömt,
 wobei ein mageres Luft/Kraftstoffverhältnis kontinuierlich verbrannt wird und das besagte Absorbens (18) einen Katalysator enthält und NO_x absorbiert, sobald das Abgas mager ist, sowie das erwähnte absorbierte NO_x freigibt, sobald die Sauerstoffkonzentration des Abgases abgesenkt wird,

wobei das Freigeben des absorbierten NO_x stattfindet, wenn das Luft/Kraftstoffverhältnis des einströmenden Abgases fett ist und wenn das Luft/Kraftstoffverhältnis stöchiometrisch ist, wobei das Luft/Kraftstoffverhältnis des Abgases fett oder stöchiometrisch gemacht wird, wenn eine konstante Menge NO_x in dem NO_x -Absorbens (18) absorbiert ist, um das absorbierte NO_x von dem NO_x -Absorbens (18) freizugeben, so dass, wenn das Abgas fett ist oder das stöchiometrische Luft/Kraftstoffverhältnis aufweist, unverbrannter Kohlenwasserstoff und Kohlenmonoxid im Abgas mit dem freigegebenen NO_x reagieren, um dadurch das NO_x zu reduzieren,

wobei der NO_x -Freigabeprozess nicht durchgeführt wird, bis die Temperatur (T) des NO_x -Absorbens (18) gleich wie oder größer als eine vorbestimmte Temperatur (T1) wird.

2. Eine Abgasreinigungsvorrichtung einer Brennkraftmaschine nach Anspruch 1, in welcher eine Zeitspanne, während der das Luft/Kraftstoffverhältnis des in das NO_x -Absorbens strömenden Abgases mager eingestellt ist und das NO_x im NO_x -Absorbens absorbiert wird, 50-mal oder mehr länger als die Zeitspanne ist, während der die Sauerstoffkonzentration im in das NO_x -Absorbens strömenden Abgas abgesenkt ist, um das NO_x vom NO_x -Absorbens freizugeben.
3. Eine Abgasreinigungsvorrichtung einer Brennkraftmaschine nach Anspruch 1, in welcher das Luft/Kraftstoffverhältnis des in das NO_x -Absorbens strömenden Abgases mehr als 18,0 beträgt, wenn das NO_x im NO_x -Absorbens absorbiert wird.
4. Eine Abgasreinigungsvorrichtung einer Brennkraftmaschine nach Anspruch 1, in welcher das NO_x -Absorbens mindestens eine aus Alkalimetallen, die Kalium, Natrium, Lithium oder Caesium umfassen, aus Erdalkalimetallen, die Barium oder Kalzium umfassen, aus Seltenerdmetallen, die Lanthan oder Yttrium umfassen, ausgewählte Substanz enthält sowie Platin einschließt.
5. Eine Abgasreinigungsvorrichtung einer Brennkraftmaschine nach Anspruch 1, in welcher das NO_x -Absorbens ein Verbundoxid von Barium und Kupfer enthält.
6. Eine Abgasreinigungsvorrichtung einer Brennkraftmaschine nach Anspruch 1, in welcher Luft/Kraftstoffverhältnis-Regleinrichtungen vorgesehen sind, um das Luft/Kraftstoffverhältnis des in einem Brennraum der Maschine gebildeten Luft/Kraftstoffgemischs zu regeln, und die Absorption des NO_x -Absorbens sowie die Freigabe von NO_x aus dem NO_x -Absorbens durch Regeln des Luft/Kraftstoffverhältnisses des im Brennraum der Maschine gebildeten Luft/Kraftstoffgemischs durch die genannten Luft/Kraftstoffverhältnis-Regleinrichtungen kontrolliert werden.
7. Eine Abgasreinigungsvorrichtung einer Brennkraftmaschine nach Anspruch 6, in welcher die genannten Luft/Kraftstoffverhältnis-Regleinrichtungen dazu eingerichtet sind, das Luft/Kraftstoffverhältnis des im Brennraum gebildeten Luft/Kraftstoffgemischs mager zu machen, wenn das NO_x im NO_x -Absorbens absorbiert werden soll, und das Luft/Kraftstoffverhältnis des im Brennraum gebildeten Luft/Kraftstoffgemischs auf das stöchiometrische Luft/Kraftstoffverhältnis oder fett einzustellen, wenn das NO_x vom NO_x -Absorbens freigegeben werden soll.
8. Eine Abgasreinigungsvorrichtung einer Brennkraftmaschine nach Anspruch 7, wobei die Brennkraftmaschine einen Ottomotor umfasst und die genannten Luft/Kraftstoffverhältnis-Regleinrichtungen die Absorption von NO_x im NO_x -Absorbens sowie das Freigeben von absorbiertem NO_x aus dem NO_x -Absorbens durch Regeln der dem Motor zugeführten Kraftstoffmenge kontrollieren.
9. Eine Abgasreinigungsvorrichtung einer Brennkraftmaschine nach Anspruch 8, in welcher die genannten Luft/Kraftstoffverhältnis-Regleinrichtungen das Luft/Kraftstoffverhältnis des im Brennraum gebildeten Luft/Kraftstoffgemischs auf nahezu einem konstanten mageren Luft/Kraftstoffverhältnis von mehr als 18,0 halten, wenn das NO_x im NO_x -Absorbens absorbiert werden soll.
10. Eine Abgasreinigungsvorrichtung einer Brennkraftmaschine nach Anspruch 8, die ferner Speichereinrichtungen umfasst, um im voraus die in Übereinstimmung mit dem Betriebszustand des Motors bestimmte Kraftstoffmenge zu speichern, wobei die genannten Luft/Kraftstoffverhältnis-Regleinrichtungen dazu eingerichtet sind, die dem Motor zugeführte Kraftstoffmenge auf der Grundlage der in den besagten Speichereinrichtungen gespeicherten Kraftstoffmenge zu bestimmen.
11. Eine Abgasreinigungsvorrichtung einer Brennkraftmaschine nach Anspruch 8, die ferner Speichereinrichtungen, um im voraus die in Übereinstimmung mit dem Betriebszustand des Motors bestimmte Basis-Kraftstoffmenge zu speichern, und einen Luft/Kraftstoffverhältnisfühler, der im Abgaskanal des Motors vorgesehen ist, um das Luft/Kraftstoffverhältnis des im Abgaskanal strömenden Abgases zu ermitteln, umfasst, wobei die genannten Luft/Kraftstoffverhältnis-Regleinrichtungen dazu eingerichtet sind, die Basis-Kraftstoffmenge zu korrigieren,

so dass das Luft/Kraftstoffverhältnis des Abgases durch einen in Übereinstimmung mit dem Ausgangssignal des erwähnten Luft/Kraftstoffverhältnisfühlers veränderten Rückführung-Korrekturkoeffizienten zum Ziel-Luft/Kraftstoffverhältnis wird.

- 5
12. Eine Abgasreinigungsvorrichtung einer Brennkraftmaschine nach Anspruch 11, in welcher die genannten Luft/Kraftstoffverhältnis-Regelrichtungen dazu eingerichtet sind, die Basis-Kraftstoffmenge so zu korrigieren, dass das Luft/Kraftstoffverhältnis des Abgases durch den Rückführung-Korrekturkoeffizienten zum Ziel-Luft/Kraftstoffverhältnis wird, wenn das NO_x im NO_x -Absorbens absorbiert werden soll, und gleichzeitig den besagten Rückführung-Korrekturkoeffizienten durch einen Lernkoeffizienten so zu korrigieren, dass der besagte Rückführung-Korrekturkoeffizient um einen Bezugswert herum fluktuiert, und in welcher die genannten Luft/Kraftstoffverhältnis-Regelrichtungen dazu eingerichtet sind, den Rückführung-Korrekturwert auf den erwähnten Bezugswert festzusetzen, wenn das NO_x vom NO_x -Absorbens freigegeben werden soll, sowie gleichzeitig die dem Motor zuzuführende Kraftstoffmenge auf der Grundlage des Lernkoeffizienten und der Basis-Kraftstoffmenge zu bestimmen.
- 10
13. Eine Abgasreinigungsvorrichtung einer Brennkraftmaschine nach Anspruch 7, wobei die Brennkraftmaschine einen Dieselmotor umfasst, der mit einem Kraftstoff-Einspritzventil, um den Kraftstoff in den Brennraum einzuspritzen, sowie mit einer im Ansaugkanal des Motors angeordneten Drosselklappe ausgestattet ist; und wobei die genannten Luft/Kraftstoffverhältnis-Regelrichtungen dazu eingerichtet sind, die Absorption von NO_x im NO_x -Absorbens sowie das Freigeben von NO_x aus dem NO_x -Absorbens durch Regeln der Einspritzmenge aus dem Kraftstoff-Einspritzventil heraus und des Öffnungsgrades der Drosselklappe zu kontrollieren.
- 15
14. Eine Abgasreinigungsvorrichtung einer Brennkraftmaschine nach Anspruch 13, in welcher die genannten Luft/Kraftstoffverhältnis-Regelrichtungen dazu eingerichtet sind, die Einspritzmenge zu vergrößern sowie den Drosselklappenöffnungsgrad zu verringern, wenn das NO_x vom NO_x -Absorbens freigegeben werden soll.
- 20
15. Eine Abgasreinigungsvorrichtung einer Brennkraftmaschine nach Anspruch 1, die ferner Luft/Kraftstoffverhältnis-Regelrichtungen umfasst, um das Luft/Kraftstoffverhältnis des aus dem Motorbrennraum ausgestoßenen sowie in das NO_x -Absorbens im Abgaskanal des Motors strömenden Abgases zu kontrollieren, wobei die Absorption des NO_x im NO_x -Absorbens und das Freigeben des

NO_x aus dem NO_x -Absorbens durch Regeln des Luft/Kraftstoffverhältnisses des in das NO_x -Absorbens strömenden Abgases durch die genannten Verhältnis-Regelrichtungen kontrollierbar ist.

- 25
16. Eine Abgasreinigungsvorrichtung einer Brennkraftmaschine nach Anspruch 15, in welcher die genannten Luft/Kraftstoffverhältnis-Regelrichtungen dazu eingerichtet sind, das Luft/Kraftstoffverhältnis des in das NO_x -Absorbens strömenden Abgases mager zu machen, wenn das NO_x im NO_x -Absorbens absorbiert werden soll, hingegen das Luft/Kraftstoffverhältnis des in das NO_x -Absorbens strömenden Abgases auf das stöchiometrische Luft/Kraftstoffverhältnis oder fett einzustellen, wenn das NO_x aus dem NO_x -Absorbens freigegeben werden soll.
- 30
17. Eine Abgasreinigungsvorrichtung einer Brennkraftmaschine nach Anspruch 16, in welcher die genannten Luft/Kraftstoffverhältnis-Regelrichtungen dazu eingerichtet sind, ein Reduktionsmittel in das Innere des Abgaskanals des Motors einzuführen, wenn das NO_x aus dem NO_x -Absorbens freigegeben werden soll.
- 35
18. Eine Abgasreinigungsvorrichtung einer Brennkraftmaschine nach Anspruch 17, wobei das genannte Reduktionsmittel aus einem Kohlenwasserstoff hergestellt ist.
- 40
19. Eine Abgasreinigungsvorrichtung einer Brennkraftmaschine nach Anspruch 18, in welcher der genannte Kohlenwasserstoff mindestens einen aus Benzin, Isooktan, Hexan, Heptan, Butan, Propan, Leichtöl und Kerosin ausgewählten Bestandteil umfasst.
- 45
20. Eine Abgasreinigungsvorrichtung einer Brennkraftmaschine nach Anspruch 1, die ferner NO_x -Freigabe-Regelrichtungen umfasst, die geeignet sind, die Sauerstoffkonzentration in dem in das NO_x -Absorbens strömenden Abgas nur für eine zweite, präliminär bestimmte Einstellzeitspanne zu vermindern, um das NO_x vom NO_x -Absorbens freizugeben, wenn die Zeitspanne, während welcher das Luft/Kraftstoffverhältnis des in das NO_x -Absorbens strömenden Abgases mager gemacht ist und das NO_x im NO_x -Absorbens absorbiert wird, eine präliminär bestimmte erste Einstellzeitspanne überschreitet.
- 50
21. Eine Abgasreinigungsvorrichtung einer Brennkraftmaschine nach Anspruch 20, in welcher die erwähnten NO_x -Freigabe-Regelrichtungen dazu eingerichtet sind, das Luft/Kraftstoffverhältnis des in das NO_x -Absorbens strömenden Abgases auf das stöchiometrische Luft/Kraftstoffverhältnis oder

fett einzustellen, wenn das NO_x vom NO_x-Absorbens freigegeben werden soll.

22. Eine Abgasreinigungsvorrichtung einer Brennkraftmaschine nach Anspruch 20, in welcher die er-
wähnten NO_x-Freigabe-Regeleinrichtungen mit einer
NO_x-Menge-Abschätzeinrichtung versehen
sind, um die Menge des im NO_x-Absorbens absor-
bierten NO_x abzuschätzen, und die erwähnten NO_x-
Freigabe-Regeleinrichtungen dazu eingerichtet
sind zu entscheiden, dass die besagte erste Ein-
stellzeitspanne verstrichen ist, wenn die Menge des
durch die NO_x-Menge-Abschätzeinrichtung ge-
schätzten NO_x einen präliminär bestimmten Ein-
stellwert überschreitet.
23. Eine Abgasreinigungsvorrichtung einer Brennkraft-
maschine nach Anspruch 22, in welcher die ge-
nannte NO_x-Menge-Abschätzeinrichtung dazu ein-
gerichtet ist zu entscheiden, dass die Menge von
im NO_x-Absorbens absorbiertem NO_x den erwähn-
ten Einstellwert überschreitet, wenn ein kumulativer
Wert einer Motordrehzahl einen präliminär be-
stimmten Einstellwert übersteigt.
24. Eine Abgasreinigungsvorrichtung einer Brennkraft-
maschine nach Anspruch 22, in welcher die ge-
nannte NO_x-Menge-Abschätzeinrichtung dazu ein-
gerichtet ist zu entscheiden, dass im wesentlichen
das gesamte, im NO_x-Absorbens absorbierte NO_x
freigegeben wurde, wenn das Luft/Kraftstoffverhält-
nis des im Motorbrennraum gebildeten Luft/Kraft-
stoffgemischs für eine vorbestimmte Zeitspanne
oder länger auf dem stöchiometrischen Luft/Kraft-
stoffverhältnis gehalten wird oder fett ist.
25. Eine Abgasreinigungsvorrichtung einer Brennkraft-
maschine nach Anspruch 20, in welcher die besag-
te zweite Einstellzeitspanne im wesentlichen gerin-
ger als 20 Sekunden ist.
26. Eine Abgasreinigungsvorrichtung einer Brennkraft-
maschine nach Anspruch 20, in welcher die er-
wähnten NO_x-Freigabe-Regeleinrichtungen mit ein-
em Temperaturfühler versehen sind, um eine Tem-
peratur des in das NO_x-Absorbens strömenden Ab-
gases zu ermitteln, und die erwähnten NO_x-Freiga-
be-Regeleinrichtungen mit Hinderungsmitteln aus-
gestattet sind, die das Vermindern der Sauerstoff-
konzentration in dem in das NO_x-Absorbens strö-
menden Abgas, auch wenn die Zeitspanne,
während welcher das NO_x im NO_x-Absorbens ab-
sorbiert wird, die besagte erste Einstellzeitspanne
überschreitet, falls die Temperatur des in das NO_x-
Absorbens strömenden Abgases niedriger als eine
Grenztemperatur wird, bei welcher das NO_x durch
das NO_x-Absorbens absorbiert werden kann, ver-
hindern.

27. Eine Abgasreinigungsvorrichtung einer Brennkraft-
maschine nach Anspruch 26, in welcher die er-
wähnten NO_x-Freigabe-Regeleinrichtungen dazu
eingerrichtet sind, die Sauerstoffkonzentration in
dem in das NO_x-Absorbens strömenden Abgas au-
genblicklich zu vermindern, sobald die Temperatur
des in das NO_x-Absorbens strömenden Abgases
höher als die besagte Grenztemperatur wird, nach-
dem die Sauerstoffkonzentration in dem in das
NO_x-Absorbens strömenden Abgas durch die er-
wähnten Hinderungsmittel vermindert ist.
28. Eine Abgasreinigungsvorrichtung einer Brennkraft-
maschine nach Anspruch 1, in welcher ein weiterer
Katalysator, der mindestens das NO_x reduzieren
kann, in dem Abgaskanal der Maschine stromab
von dem NO_x-Absorbens angeordnet ist.
29. Eine Abgasreinigungsvorrichtung einer Brennkraft-
maschine nach Anspruch 28, in welcher der ge-
nannte Katalysator einen Dreibegekatalsator um-
fasst.
30. Eine Abgasreinigungsvorrichtung einer Brennkraft-
maschine nach Anspruch 1, in welcher ein weiterer
Katalysator, der unverbrannten Kohlenwasserstoff
und Kohlenmonoxid reinigen kann, im Abgaskanal
der Maschine stromauf von dem NO_x-Absorbens
angeordnet ist.
31. Eine Abgasreinigungsvorrichtung einer Brennkraft-
maschine nach Anspruch 30, in welcher der besag-
te Katalysator einen Dreibegekatalsator umfasst.

Patentansprüche für folgende Vertragsstaaten : ES, IT, SE

1. Eine Abgasreinigungsvorrichtung einer Magerver-
brennungs-Brennkraftmaschine (1) umfasst ein in
einem Abgaskanal (17) der genannten Maschine
(1) angeordnetes NO_x-Absorbens (18), wobei das
Abgas während eines Betriebs der genannten Ma-
schine (1) kontinuierlich in das NO_x-Absorbens (18)
strömt,
wobei das besagte Absorbens (18) einen Katalysator
enthält und NO_x absorbiert, sobald das Abgas mager
ist, sowie das erwähnte absorbierte NO_x freigibt,
sobald die Sauerstoffkonzentration des Abgases
abgesenkt wird,
so dass, wenn das Abgas fett ist oder das stöchiometrische
Luft/Kraftstoffverhältnis aufweist, unverbrannter
Kohlenwasserstoff und Kohlenmonoxid im Abgas mit
dem freigegebenen NO_x reagieren, um dadurch das
NO_x zu reduzieren.
2. Eine Abgasreinigungsvorrichtung einer Brennkraft-
maschine nach Anspruch 1, in welcher eine Zeit-

- spanne, während der das Luft/Kraftstoffverhältnis des in das NO_x-Absorbens strömenden Abgases mager eingestellt ist und das NO_x im NO_x-Absorbens absorbiert wird, 50-mal oder mehr länger als die Zeitspanne ist, während der die Sauerstoffkonzentration im in das NO_x-Absorbens strömenden Abgas abgesenkt ist, um das NO_x vom NO_x-Absorbens freizugeben.
- 5
3. Eine Abgasreinigungsvorrichtung einer Brennkraftmaschine nach Anspruch 1, in welcher das Luft/Kraftstoffverhältnis des in das NO_x-Absorbens strömenden Abgases mehr als 18,0 beträgt, wenn das NO_x im NO_x-Absorbens absorbiert wird.
- 10
4. Eine Abgasreinigungsvorrichtung einer Brennkraftmaschine nach Anspruch 1, in welcher das NO_x-Absorbens mindestens eine aus Alkalimetallen, die Kalium, Natrium, Lithium oder Caesium umfassen, aus Erdalkalimetallen, die Barium oder Kalzium umfassen, aus Seltenerdmetallen, die Lanthan oder Yttrium umfassen, ausgewählte Substanz enthält sowie Platin einschließt.
- 15
- 20
5. Eine Abgasreinigungsvorrichtung einer Brennkraftmaschine nach Anspruch 1, in welcher das NO_x-Absorbens ein Verbundoxid von Barium und Kupfer enthält.
- 25
6. Eine Abgasreinigungsvorrichtung einer Brennkraftmaschine nach Anspruch 1, in welcher Luft/Kraftstoffverhältnis-Regelrichtungen vorgesehen sind, um das Luft/Kraftstoffverhältnis des in einem Brennraum der Maschine gebildeten Luft/Kraftstoffgemischs zu regeln, und die Absorption des NO_x-Absorbens sowie die Freigabe von NO_x aus dem NO_x-Absorbens durch Regeln des Luft/Kraftstoffverhältnisses des im Brennraum der Maschine gebildeten Luft/Kraftstoffgemischs durch die genannten Luft/Kraftstoffverhältnis-Regelrichtungen kontrolliert werden.
- 30
- 35
- 40
7. Eine Abgasreinigungsvorrichtung einer Brennkraftmaschine nach Anspruch 6, in welcher die genannten Luft/Kraftstoffverhältnis-Regelrichtungen dazu eingerichtet sind, das Luft/Kraftstoffverhältnis des im Brennraum gebildeten Luft/Kraftstoffgemischs mager zu machen, wenn das NO_x im NO_x-Absorbens absorbiert werden soll, und das Luft/Kraftstoffverhältnis des im Brennraum gebildeten Luft/Kraftstoffgemischs auf das stöchiometrische Luft/Kraftstoffverhältnis oder fett einzustellen, wenn das NO_x vom NO_x-Absorbens freigegeben werden soll.
- 45
- 50
8. Eine Abgasreinigungsvorrichtung einer Brennkraftmaschine nach Anspruch 7, wobei die Brennkraftmaschine einen Ottomotor umfasst und die genannten Luft/Kraftstoffverhältnis-Regelrichtungen die Absorption von NO_x im NO_x-Absorbens sowie das Freigeben von absorbiertem NO_x aus dem NO_x-Absorbens durch Regeln der dem Motor zugeführten Kraftstoffmenge kontrollieren.
- 5
9. Eine Abgasreinigungsvorrichtung einer Brennkraftmaschine nach Anspruch 8, in welcher die genannten Luft/Kraftstoffverhältnis-Regelrichtungen das Luft/Kraftstoffverhältnis des im Brennraum gebildeten Luft/Kraftstoffgemischs auf nahezu einem konstanten mageren Luft/Kraftstoffverhältnis von mehr als 18,0 halten, wenn das NO_x im NO_x-Absorbens absorbiert werden soll.
- 10
10. Eine Abgasreinigungsvorrichtung einer Brennkraftmaschine nach Anspruch 8, die ferner Speichereinrichtungen umfasst, um im voraus die in Übereinstimmung mit dem Betriebszustand des Motors bestimmte Kraftstoffmenge zu speichern, wobei die genannten Luft/Kraftstoffverhältnis-Regelrichtungen dazu eingerichtet sind, die dem Motor zugeführte Kraftstoffmenge auf der Grundlage der in den besagten Speichereinrichtungen gespeicherten Kraftstoffmenge zu bestimmen.
11. Eine Abgasreinigungsvorrichtung einer Brennkraftmaschine nach Anspruch 8, die ferner Speichereinrichtungen, um im voraus die in Übereinstimmung mit dem Betriebszustand des Motors bestimmte Basis-Kraftstoffmenge zu speichern, und einen Luft/Kraftstoffverhältnisfühler, der im Abgaskanal des Motors vorgesehen ist, um das Luft/Kraftstoffverhältnis des im Abgaskanal strömenden Abgases zu ermitteln, umfasst, wobei die genannten Luft/Kraftstoffverhältnis-Regelrichtungen dazu eingerichtet sind, die Basis-Kraftstoffmenge zu korrigieren, so dass das Luft/Kraftstoffverhältnis des Abgases durch einen in Übereinstimmung mit dem Ausgangssignal des erwähnten Luft/Kraftstoffverhältnisfühlers veränderten Rückführung-Korrekturkoeffizienten zum Ziel-Luft/Kraftstoffverhältnis wird.
12. Eine Abgasreinigungsvorrichtung einer Brennkraftmaschine nach Anspruch 11, in welcher die genannten Luft/Kraftstoffverhältnis-Regelrichtungen dazu eingerichtet sind, die Basis-Kraftstoffmenge so zu korrigieren, dass das Luft/Kraftstoffverhältnis des Abgases durch den Rückführung-Korrekturkoeffizienten zum Ziel-Luft/Kraftstoffverhältnis wird, wenn das NO_x im NO_x-Absorbens absorbiert werden soll, und gleichzeitig den besagten Rückführung-Korrekturkoeffizienten durch einen Lernkoeffizienten so zu korrigieren, dass der besagte Rückführung-Korrekturkoeffizient um einen Bezugswert herum fluktuiert, und in welcher die genannten Luft/Kraftstoffverhältnis-Regelrichtungen dazu eingerichtet sind, den Rückführung-Kor-

rekturwert auf den erwähnten Bezugswert festzusetzen, wenn das NO_x vom NO_x -Absorbens freigegeben werden soll, sowie gleichzeitig die dem Motor zuzuführende Kraftstoffmenge auf der Grundlage des Lernkoeffizienten und der Basis-Kraftstoffmenge zu bestimmen.

- 5
13. Eine Abgasreinigungsvorrichtung einer Brennkraftmaschine nach Anspruch 7, wobei die Brennkraftmaschine einen Dieselmotor umfasst, der mit einem Kraftstoff-Einspritzventil, um den Kraftstoff in den Brennraum einzuspritzen, sowie mit einer im Ansaugkanal des Motors angeordneten Drosselklappe ausgestattet ist; und wobei die genannten Luft/Kraftstoffverhältnis-Regleinrichtungen dazu eingerichtet sind, die Absorption von NO_x im NO_x -Absorbens sowie das Freigeben von NO_x aus dem NO_x -Absorbens durch Regeln der Einspritzmenge aus dem Kraftstoff-Einspritzventil heraus und des Öffnungsgrades der Drosselklappe zu kontrollieren.
- 10
14. Eine Abgasreinigungsvorrichtung einer Brennkraftmaschine nach Anspruch 13, in welcher die genannten Luft/Kraftstoffverhältnis-Regleinrichtungen dazu eingerichtet sind, die Einspritzmenge zu vergrößern sowie den Drosselklappenöffnungsgrad zu verringern, wenn das NO_x vom NO_x -Absorbens freigegeben werden soll.
- 15
15. Eine Abgasreinigungsvorrichtung einer Brennkraftmaschine nach Anspruch 1, die ferner Luft/Kraftstoffverhältnis-Regleinrichtungen umfasst, um das Luft/Kraftstoffverhältnis des aus dem Motorbrennraum ausgestoßenen sowie in das NO_x -Absorbens im Abgaskanal des Motors strömenden Abgases zu kontrollieren, wobei die Absorption des NO_x im NO_x -Absorbens und das Freigeben des NO_x aus dem NO_x -Absorbens durch Regeln des Luft/Kraftstoffverhältnisses des in das NO_x -Absorbens strömenden Abgases durch die genannten Verhältnis-Regleinrichtungen kontrollierbar ist.
- 20
16. Eine Abgasreinigungsvorrichtung einer Brennkraftmaschine nach Anspruch 15, in welcher die genannten Luft/Kraftstoffverhältnis-Regleinrichtungen dazu eingerichtet sind, das Luft/Kraftstoffverhältnis des in das NO_x -Absorbens strömenden Abgases mager zu machen, wenn das NO_x im NO_x -Absorbens absorbiert werden soll, hingegen das Luft/Kraftstoffverhältnis des in das NO_x -Absorbens strömenden Abgases auf das stöchiometrische Luft/Kraftstoffverhältnis oder fett einzustellen, wenn das NO_x aus dem NO_x -Absorbens freigegeben werden soll.
- 25
17. Eine Abgasreinigungsvorrichtung einer Brennkraftmaschine nach Anspruch 16, in welcher die genannten Luft/Kraftstoffverhältnis-Regleinrichtungen

gen dazu eingerichtet sind, ein Reduktionsmittel in das Innere des Abgaskanals des Motors einzuführen, wenn das NO_x aus dem NO_x -Absorbens freigegeben werden soll.

- 5
18. Eine Abgasreinigungsvorrichtung einer Brennkraftmaschine nach Anspruch 17, wobei das genannte Reduktionsmittel aus einem Kohlenwasserstoff hergestellt ist.
- 10
19. Eine Abgasreinigungsvorrichtung einer Brennkraftmaschine nach Anspruch 18, in welcher der genannte Kohlenwasserstoff mindestens einen aus Benzin, Isooktan, Hexan, Heptan, Butan, Propan, Leichtöl und Kerosin ausgewählten Bestandteil umfasst.
- 15
20. Eine Abgasreinigungsvorrichtung einer Brennkraftmaschine nach Anspruch 1, die ferner NO_x -Freigabe-Regleinrichtungen umfasst, die geeignet sind, die Sauerstoffkonzentration in dem in das NO_x -Absorbens strömenden Abgas nur für eine zweite, präliminär bestimmte Einstellzeitspanne zu vermindern, um das NO_x vom NO_x -Absorbens freizugeben, wenn die Zeitspanne, während welcher das Luft/Kraftstoffverhältnis des in das NO_x -Absorbens strömenden Abgases mager gemacht ist und das NO_x im NO_x -Absorbens absorbiert wird, eine präliminär bestimmte erste Einstellzeitspanne überschreitet.
- 20
21. Eine Abgasreinigungsvorrichtung einer Brennkraftmaschine nach Anspruch 20, in welcher die erwähnten NO_x -Freigabe-Regleinrichtungen dazu eingerichtet sind, das Luft/Kraftstoffverhältnis des in das NO_x -Absorbens strömenden Abgases auf das stöchiometrische Luft/Kraftstoffverhältnis oder fett einzustellen, wenn das NO_x vom NO_x -Absorbens freigegeben werden soll.
- 25
22. Eine Abgasreinigungsvorrichtung einer Brennkraftmaschine nach Anspruch 20, in welcher die erwähnten NO_x -Freigabe-Regleinrichtungen mit einer NO_x -Menge-Abschätzeinrichtung versehen sind, um die Menge des im NO_x -Absorbens absorbierten NO_x abzuschätzen, und die erwähnten NO_x -Freigabe-Regleinrichtungen dazu eingerichtet sind zu entscheiden, dass die besagte erste Einstellzeitspanne verstrichen ist, wenn die Menge des durch die NO_x -Menge-Abschätzeinrichtung geschätzten NO_x einen präliminär bestimmten Einstellwert überschreitet.
- 30
23. Eine Abgasreinigungsvorrichtung einer Brennkraftmaschine nach Anspruch 22, in welcher die genannte NO_x -Menge-Abschätzeinrichtung dazu eingerichtet ist zu entscheiden, dass die Menge von im NO_x -Absorbens absorbiertem NO_x den erwähnten
- 35
- 40
- 45
- 50
- 55

ten Einstellwert überschreitet, wenn ein kumulativer Wert einer Motordrehzahl einen präliminär bestimmten Einstellwert übersteigt.

24. Eine Abgasreinigungsvorrichtung einer Brennkraftmaschine nach Anspruch 22, in welcher die genannte NO_x -Menge-Abschätzeinrichtung dazu eingerichtet ist zu entscheiden, dass im wesentlichen das gesamte, im NO_x -Absorbens absorbierte NO_x freigegeben wurde, wenn das Luft/Kraftstoffverhältnis des im Motorbrennraum gebildeten Luft/Kraftstoffgemischs für eine vorbestimmte Zeitspanne oder länger auf dem stöchiometrischen Luft/Kraftstoffverhältnis gehalten wird oder fett ist.
25. Eine Abgasreinigungsvorrichtung einer Brennkraftmaschine nach Anspruch 20, in welcher die besagte zweite Einstellzeitspanne im wesentlichen geringer als 20 Sekunden ist.
26. Eine Abgasreinigungsvorrichtung einer Brennkraftmaschine nach Anspruch 20, in welcher die erwähnten NO_x -Freigabe-Regleinrichtungen mit einem Temperaturfühler versehen sind, um eine Temperatur des in das NO_x -Absorbens strömenden Abgases zu ermitteln, und die erwähnten NO_x -Freigabe-Regleinrichtungen mit Hinderungsmitteln ausgestattet sind, die das Vermindern der Sauerstoffkonzentration in dem in das NO_x -Absorbens strömenden Abgas, auch wenn die Zeitspanne, während welcher das NO_x im NO_x -Absorbens absorbiert wird, die besagte erste Einstellzeitspanne überschreitet, falls die Temperatur des in das NO_x -Absorbens strömenden Abgases niedriger als eine Grenztemperatur wird, bei welcher das NO_x durch das NO_x -Absorbens absorbiert werden kann, verhindern.
27. Eine Abgasreinigungsvorrichtung einer Brennkraftmaschine nach Anspruch 26, in welcher die erwähnten NO_x -Freigabe-Regleinrichtungen dazu eingerichtet sind, die Sauerstoffkonzentration in dem in das NO_x -Absorbens strömenden Abgas augenblicklich zu vermindern, sobald die Temperatur des in das NO_x -Absorbens strömenden Abgases höher als die besagte Grenztemperatur wird, nachdem die Sauerstoffkonzentration in dem in das NO_x -Absorbens strömenden Abgas durch die erwähnten Hinderungsmittel vermindert ist.
28. Eine Abgasreinigungsvorrichtung einer Brennkraftmaschine nach Anspruch 1, in welcher ein weiterer Katalysator, der mindestens das NO_x reduzieren kann, in dem Abgaskanal der Maschine stromab von dem NO_x -Absorbens angeordnet ist.
29. Eine Abgasreinigungsvorrichtung einer Brennkraftmaschine nach Anspruch 28, in welcher der ge-

nannte Katalysator einen Dreiwegekatalysator umfasst.

30. Eine Abgasreinigungsvorrichtung einer Brennkraftmaschine nach Anspruch 1, in welcher ein weiterer Katalysator, der unverbrannten Kohlenwasserstoff und Kohlenmonoxid reinigen kann, im Abgaskanal der Maschine stromauf von dem NO_x -Absorbens angeordnet ist.
31. Eine Abgasreinigungsvorrichtung einer Brennkraftmaschine nach Anspruch 30, in welcher der besagte Katalysator einen Dreiwegekatalysator umfasst.

Revendications

Revendications pour les Etats contractants suivants : DE, FR, GB

- Un dispositif d'épuration de gaz d'échappement d'un moteur à combustion interne (1) d'un gaz brûlé pauvre comprenant un absorbant de NO_x (18) disposé dans un passage d'échappement (17) dudit moteur (1), dans lequel le gaz d'échappement circule de manière continue sur l'absorbant de NO_x (18) pendant le fonctionnement dudit moteur (1), **caractérisé en ce que** le mélange air-carburant pauvre est brûlé en continu, **en ce que** ledit absorbant de NO_x (18) comprend un catalyseur et absorbe le NO_x , lorsque le gaz d'échappement est pauvre, et libère ledit NO_x absorbé, lorsque la concentration en oxygène du gaz d'échappement est abaissée, **en ce que** le dégagement du NO_x absorbé se produit lorsque le rapport air-carburant du gaz d'échappement entrant est riche et que le rapport air-carburant est stoechiométrique, **en ce que** le rapport air-carburant du gaz d'échappement est rendu riche, ou stoechiométrique quand une quantité constante de NO_x est absorbée dans l'absorbant (18) du NO_x pour libérer le NO_x absorbé de l'absorbant (18) de NO_x , de telle sorte que, lorsque le gaz d'échappement est riche ou correspond au rapport air/carburant stoechiométrique, CO et les HC non brûlés présents dans le gaz d'échappement réagissent avec le NO_x libéré, de manière à réduire le NO_x , et dans lequel le procédé de libération du NO_x n'est mis en oeuvre qu'après que la température (T) de l'absorbant (18) du NO_x soit égale à, ou supérieure, à une température prédéterminée (T1).
- Un dispositif d'épuration du gaz d'échappement d'un moteur à combustion interne selon la revendication 1, dans lequel la durée pendant laquelle le rapport air/carburant du gaz d'échappement qui s'écoule dans l'absorbant de NO_x est rendu pauvre et le NO_x est absorbé dans l'absorbant de NO_x , est

50 fois plus longue que la durée pendant laquelle la concentration en oxygène du gaz d'échappement qui s'écoule dans l'absorbant de NO_x est diminuée afin de libérer le NO_x de l'absorbant de NO_x .

3. Un dispositif d'épuration du gaz d'échappement d'un moteur à combustion interne selon la revendication 1, dans lequel le rapport air/carburant du gaz d'échappement qui s'écoule dans l'absorbant de NO_x est supérieur à 18,0 quand le NO_x est absorbé dans l'absorbant de NO_x .
4. Un dispositif d'épuration du gaz d'échappement d'un moteur à combustion interne selon la revendication 1, dans lequel l'absorbant de NO_x contient au moins une substance choisie parmi les métaux alcalins comprenant le potassium, le sodium, le lithium ou le césium, les métaux alcalino-terreux comprenant le baryum ou le calcium, les métaux de terres rares comprenant le lanthane ou l'yttrium, et contient du platine.
5. Un dispositif d'épuration du gaz d'échappement d'un moteur à combustion interne selon la revendication 1, dans lequel l'absorbant de NO_x comprend un oxyde composite de baryum et de cuivre.
6. Un dispositif d'épuration du gaz d'échappement d'un moteur à combustion interne selon la revendication 1, dans lequel des moyens de contrôle du rapport air/carburant sont prévus pour contrôler le rapport air/carburant du mélange air/carburant formé dans une chambre de combustion du moteur, et dans lequel l'absorption par l'absorbant de NO_x et la libération du NO_x à partir de l'absorbant de NO_x sont contrôlés en contrôlant le rapport air/carburant du mélange air/carburant formé dans la chambre de combustion du moteur par l'intermédiaire desdits moyens de contrôle du rapport air/carburant.
7. Un dispositif d'épuration du gaz d'échappement d'un moteur à combustion interne selon la revendication 6, dans lequel lesdits moyens de contrôle du rapport air/carburant sont aptes à rendre pauvre le rapport air/carburant du mélange air/carburant formé dans la chambre de combustion lorsque le NO_x doit être absorbé dans l'absorbant de NO_x , et à rendre le rapport air/carburant du mélange air/carburant formé dans la chambre de combustion égal au rapport air/carburant stoechiométrique ou riche lorsque le NO_x doit être libéré de l'absorbant de NO_x .
8. Un dispositif d'épuration du gaz d'échappement d'un moteur à combustion interne selon la revendication 7, dans lequel le moteur à combustion interne comprend un moteur à essence et dans lequel lesdits moyens de contrôle du rapport air/carburant

contrôlent l'absorption de NO_x dans l'absorbant de NO_x et la libération de NO_x absorbé en contrôlant la quantité de carburant fournie au moteur.

- 5 9. Un dispositif d'épuration du gaz d'échappement d'un moteur à combustion interne selon la revendication 8, dans lequel lesdits moyens de contrôle du rapport air/carburant maintiennent le rapport air/carburant du mélange air/carburant formé dans la chambre de combustion à un rapport air/carburant pauvre presque constant, supérieur à 18,0 lorsque le NO_x doit être absorbé dans l'absorbant de NO_x .
- 10 10. Un dispositif d'épuration du gaz d'échappement d'un moteur à combustion interne selon la revendication 8, comprenant en outre des moyens de mise en mémoire destinés à mettre en mémoire à l'avance la quantité de carburant déterminée en fonction de l'état de fonctionnement du moteur, lesdits moyens de contrôle du rapport air/carburant étant aptes à déterminer la quantité de carburant fournie au moteur sur la base de la quantité de carburant stockée dans lesdits moyens de mise en mémoire.
- 25 11. Un dispositif d'épuration du gaz d'échappement d'un moteur à combustion interne selon la revendication 8, comprenant en outre des moyens de mise en mémoire destinés à mettre en mémoire à l'avance la quantité de carburant de base déterminée en fonction de l'état de fonctionnement du moteur et un capteur du rapport air/carburant qui est prévu dans le passage d'échappement du moteur afin de mesurer le rapport air/carburant du gaz d'échappement qui s'écoule dans le passage d'échappement, lesdits moyens de contrôle du rapport air/carburant étant aptes à corriger la quantité de carburant de base, de telle sorte que le rapport air/carburant du gaz d'échappement devienne le rapport air/carburant de consigne, par un coefficient de correction à rétroaction qui varie en fonction du signal de sortie dudit capteur de rapport air/carburant.
- 30 35 40 45 50 55 12. Un dispositif d'épuration du gaz d'échappement d'un moteur à combustion interne selon la revendication 11, dans lequel lesdits moyens de contrôle du rapport air/carburant sont aptes à corriger la quantité de carburant de base, de telle sorte que le rapport air/carburant du gaz d'échappement devienne le rapport air/carburant de consigne, par le coefficient de correction à rétroaction, lorsque le NO_x doit être absorbé dans l'absorbant de NO_x et, en même temps, à corriger ledit coefficient de correction à rétroaction par un coefficient d'apprentissage de telle sorte que ledit coefficient de correction à rétroaction fluctue autour d'une valeur de référence, et dans lequel lesdits moyens de contrôle du rapport air/carburant sont aptes à fixer la valeur de la correction à rétroaction à ladite valeur de référen-

ce lorsque le NO_x doit être libéré de l'absorbant de NO_x et, en même temps, à déterminer la quantité de carburant à fournir au moteur sur la base du coefficient d'apprentissage et de la quantité de carburant de base.

13. Un dispositif d'épuration du gaz d'échappement d'un moteur à combustion interne selon la revendication 7, dans lequel le moteur à combustion interne comprend un moteur diesel équipé d'un injecteur de carburant pour injecter du carburant dans la chambre de combustion et d'une soupape d'étranglement disposée dans le passage d'admission du moteur; et lesdits moyens de contrôle du rapport air/carburant sont aptes à contrôler l'absorption de NO_x dans l'absorbant de NO_x et la libération de NO_x de l'absorbant de NO_x par contrôle de la quantité de carburant à injecter par l'injecteur et du degré d'ouverture de la soupape d'étranglement.
14. Un dispositif d'épuration du gaz d'échappement d'un moteur à combustion interne selon la revendication 13, dans lequel lesdits moyens de contrôle du rapport air/carburant sont aptes à augmenter la quantité à injecter et pour diminuer le degré d'ouverture de la soupape d'étranglement lorsque le NO_x doit être libéré de l'absorbant de NO_x .
15. Un dispositif d'épuration du gaz d'échappement d'un moteur à combustion interne selon la revendication 1, comprenant en outre des moyens de contrôle du rapport air/carburant destinés à contrôler le rapport air/carburant du gaz d'échappement rejeté de la chambre de combustion du moteur et s'écoulant dans l'absorbant de NO_x disposé dans le passage d'échappement du moteur, et l'absorption de NO_x dans l'absorbant de NO_x et la libération de NO_x de l'absorbant de NO_x pouvant d'être contrôlés en contrôlant le rapport air/carburant du gaz d'échappement qui s'écoule dans l'absorbant de NO_x à l'aide desdits moyens de contrôle du rapport.
16. Un dispositif d'épuration du gaz d'échappement d'un moteur à combustion interne selon la revendication 15, dans lequel lesdits moyens de contrôle du rapport air/carburant sont aptes à rendre pauvre le rapport air/carburant du gaz d'échappement qui s'écoule dans l'absorbant de NO_x lorsque le NO_x doit être absorbé dans l'absorbant de NO_x , et à rendre le rapport air/carburant du gaz d'échappement s'écoulant dans l'absorbant de NO_x égal au rapport air/carburant stoechiométrique ou riche lorsque le NO_x doit être libéré de l'absorbant de NO_x .
17. Un dispositif d'épuration du gaz d'échappement d'un moteur à combustion interne selon la revendication 16, dans lequel lesdits moyens de contrôle du rapport air/carburant sont aptes à fournir un

agent réducteur à l'intérieur du passage d'échappement du moteur lorsque le NO_x doit être libéré de l'absorbant de NO_x .

- 5 18. Un dispositif d'épuration du gaz d'échappement d'un moteur à combustion interne selon la revendication 17, dans lequel ledit agent réducteur est constitué par un hydrocarbure.
- 10 19. Un dispositif d'épuration du gaz d'échappement d'un moteur à combustion interne selon la revendication 18, dans lequel ledit hydrocarbure comprend au moins un élément choisi parmi l'essence, l'isooctane, l'hexane, l'heptane, le butane, le propane, l'huile légère et le kérosène.
- 15 20. Un dispositif d'épuration du gaz d'échappement d'un moteur à combustion interne selon la revendication 1, comprenant en outre des moyens de contrôle de la libération de NO_x qui sont appropriés pour réduire la concentration en oxygène du gaz d'échappement qui s'écoule dans l'absorbant de NO_x seulement pendant une seconde période fixe, déterminée au préalable de manière à libérer le NO_x de l'absorbant de NO_x lorsque la période pendant laquelle le rapport air/carburant du gaz d'échappement qui s'écoule dans l'absorbant de NO_x est rendu pauvre et le NO_x est absorbé dans l'absorbant de NO_x , dépasse une première période fixe déterminée au préalable.
- 20 21. Un dispositif d'épuration du gaz d'échappement d'un moteur à combustion interne selon la revendication 20, dans lequel lesdits moyens de contrôle de la libération de NO_x sont aptes à rendre le rapport air/carburant du gaz d'échappement qui s'écoule dans l'absorbant de NO_x égal au rapport air/carburant stoechiométrique ou riche lorsque le NO_x doit être libéré de l'absorbant de NO_x .
- 25 22. Un dispositif d'épuration du gaz d'échappement d'un moteur à combustion interne selon la revendication 20, dans lequel lesdits moyens de contrôle de la libération de NO_x sont dotés de moyens d'estimation de la quantité de NO_x absorbée dans l'absorbant de NO_x , et lesdits moyens de contrôle de la libération de NO_x sont aptes à décider que ladite première période fixe s'est écoulée lorsque la quantité de NO_x estimée par les moyens d'estimation de la quantité de NO_x dépasse une quantité fixe déterminée au préalable.
- 30 23. Un dispositif d'épuration du gaz d'échappement d'un moteur à combustion interne selon la revendication 22, dans lequel lesdits moyens d'estimation de la quantité de NO_x sont aptes à décider que la quantité de NO_x absorbée dans l'absorbant de NO_x dépasse ladite quantité fixée lorsqu'une valeur cu-

mulée d'une vitesse du moteur dépasse une valeur fixe déterminée au préalable.

24. Un dispositif d'épuration du gaz d'échappement d'un moteur à combustion interne selon la revendication 22, dans lequel lesdits moyens d'estimation de la quantité de NO_x sont aptes à décider si le NO_x absorbé dans l'absorbant de NO_x a été libéré sensiblement en totalité lorsque le rapport air/carburant du mélange air/carburant formé dans la chambre de combustion du moteur est maintenu au niveau du rapport air/carburant stoechiométrique ou est riche pendant une durée prédéterminée ou plus longtemps.
25. Un dispositif d'épuration du gaz d'échappement d'un moteur à combustion interne selon la revendication 20, dans lequel ladite seconde durée fixée est sensiblement inférieure à 20 secondes.
26. Un dispositif d'épuration du gaz d'échappement d'un moteur à combustion interne selon la revendication 20, dans lequel lesdits moyens de contrôle de la libération de NO_x sont munis d'un capteur de température afin de mesurer la température du gaz d'échappement qui s'écoule dans l'absorbant de NO_x , et lesdits moyens de contrôle de la libération de NO_x sont munis de moyens d'interdiction qui interdisent la diminution de la concentration en oxygène du gaz d'échappement qui s'écoule dans l'absorbant de NO_x même si la période pendant laquelle le NO_x est absorbé dans l'absorbant de NO_x dépasse ladite première période fixée, lorsque la température du gaz d'échappement qui s'écoule dans l'absorbant de NO_x devient inférieure à une température limite pour laquelle le NO_x peut être absorbé par l'absorbant de NO_x .
27. Un dispositif d'épuration du gaz d'échappement d'un moteur à combustion interne selon la revendication 26, dans lequel lesdits moyens de contrôle de la libération de NO_x sont aptes à diminuer immédiatement la concentration en oxygène du gaz d'échappement qui s'écoule dans l'absorbant de NO_x lorsque la température du gaz d'échappement qui s'écoule dans l'absorbant de NO_x devient supérieure à ladite température limite après que la concentration en oxygène du gaz d'échappement qui s'écoule dans l'absorbant de NO_x ait été diminuée par lesdits moyens d'interdiction.
28. Un dispositif d'épuration du gaz d'échappement d'un moteur à combustion interne selon la revendication 1, dans lequel un autre catalyseur capable de réduire au moins le NO_x est disposé dans le passage d'échappement du moteur, en aval de l'absorbant de NO_x .

29. Un dispositif d'épuration du gaz d'échappement d'un moteur à combustion interne selon la revendication 28, dans lequel ledit catalyseur comprend un catalyseur à trois voies.

30. Un dispositif d'épuration du gaz d'échappement d'un moteur à combustion interne selon la revendication 1, dans lequel un autre catalyseur capable de purifier la quantité de HC et de CO non brûlés, est disposé dans le passage d'échappement du moteur, en amont de l'absorbant de NO_x .

31. Un dispositif d'épuration du gaz d'échappement d'un moteur à combustion interne selon la revendication 30, dans lequel ledit catalyseur comprend un catalyseur à trois voies.

Revendications pour les Etats contractants suivants : ES, IT, SE

1. Un dispositif d'épuration de gaz d'échappement d'un moteur à combustion interne (1) d'un gaz brûlé pauvre comprenant un absorbant de NO_x (18) disposé dans un passage d'échappement (17) dudit moteur (1), dans lequel le gaz d'échappement circule de manière continue sur l'absorbant de NO_x (18) pendant le fonctionnement dudit moteur (1), **caractérisé en ce que** ledit absorbant de NO_x (18) comprend un catalyseur et absorbe le NO_x , lorsque le gaz d'échappement est pauvre, et libère ledit NO_x absorbé, lorsque la concentration en oxygène du gaz d'échappement est abaissée, de telle sorte que, lorsque le gaz d'échappement est riche ou correspond au rapport air/carburant stoechiométrique, CO et les HC non brûlés présents dans le gaz d'échappement réagissent avec le NO_x libéré, de manière à réduire le NO_x .
2. Un dispositif d'épuration du gaz d'échappement d'un moteur à combustion interne selon la revendication 1, dans lequel la durée pendant laquelle le rapport air/carburant du gaz d'échappement qui s'écoule dans l'absorbant de NO_x est rendu pauvre et le NO_x est absorbé dans l'absorbant de NO_x , est 50 fois plus longue que la durée pendant laquelle la concentration en oxygène du gaz d'échappement qui s'écoule dans l'absorbant de NO_x est diminuée afin de libérer le NO_x de l'absorbant de NO_x .
3. Un dispositif d'épuration du gaz d'échappement d'un moteur à combustion interne selon la revendication 1, dans lequel le rapport air/carburant du gaz d'échappement qui s'écoule dans l'absorbant de NO_x est supérieur à 18,0 quand le NO_x est absorbé dans l'absorbant de NO_x .
4. Un dispositif d'épuration du gaz d'échappement

- d'un moteur à combustion interne selon la revendication 1, dans lequel l'absorbant de NO_x contient au moins une substance choisie parmi les métaux alcalins comprenant le potassium, le sodium, le lithium ou le césium, les métaux alcalino-terreux comprenant le baryum ou le calcium, les métaux de terres rares comprenant le lanthane ou l'yttrium, et contient du platine.
- 5
5. Un dispositif d'épuration du gaz d'échappement d'un moteur à combustion interne selon la revendication 1, dans lequel l'absorbant de NO_x comprend un oxyde composite de baryum et de cuivre.
- 10
6. Un dispositif d'épuration du gaz d'échappement d'un moteur à combustion interne selon la revendication 1, dans lequel des moyens de contrôle du rapport air/carburant sont prévus pour contrôler le rapport air/carburant du mélange air/carburant formé dans une chambre de combustion du moteur, et dans lequel l'absorption par l'absorbant de NO_x et la libération du NO_x à partir de l'absorbant de NO_x sont contrôlés en contrôlant le rapport air/carburant du mélange air/carburant formé dans la chambre de combustion du moteur par l'intermédiaire desdits moyens de contrôle du rapport air/carburant.
- 15
- 20
- 25
7. Un dispositif d'épuration du gaz d'échappement d'un moteur à combustion interne selon la revendication 6, dans lequel lesdits moyens de contrôle du rapport air/carburant sont aptes à rendre pauvre le rapport air/carburant du mélange air/carburant formé dans la chambre de combustion lorsque le NO_x doit être absorbé dans l'absorbant de NO_x , et à rendre le rapport air/carburant du mélange air/carburant formé dans la chambre de combustion égal au rapport air/carburant stoechiométrique ou riche lorsque le NO_x doit être libéré de l'absorbant de NO_x .
- 30
- 35
- 40
8. Un dispositif d'épuration du gaz d'échappement d'un moteur à combustion interne selon la revendication 7, dans lequel le moteur à combustion interne comprend un moteur à essence et dans lequel lesdits moyens de contrôle du rapport air/carburant contrôlent l'absorption de NO_x dans l'absorbant de NO_x et la libération de NO_x absorbé en contrôlant la quantité de carburant fournie au moteur.
- 45
9. Un dispositif d'épuration du gaz d'échappement d'un moteur à combustion interne selon la revendication 8, dans lequel lesdits moyens de contrôle du rapport air/carburant maintiennent le rapport air/carburant du mélange air/carburant formé dans la chambre de combustion à un rapport air/carburant pauvre presque constant, supérieur à 18,0 lorsque le NO_x doit être absorbé dans l'absorbant de NO_x .
- 50
- 55
10. Un dispositif d'épuration du gaz d'échappement d'un moteur à combustion interne selon la revendication 8, comprenant en outre des moyens de mise en mémoire destinés à mettre en mémoire à l'avance la quantité de carburant déterminée en fonction de l'état de fonctionnement du moteur, lesdits moyens de contrôle du rapport air/carburant étant aptes à déterminer la quantité de carburant fournie au moteur sur la base de la quantité de carburant stockée dans lesdits moyens de mise en mémoire.
11. Un dispositif d'épuration du gaz d'échappement d'un moteur à combustion interne selon la revendication 8, comprenant en outre des moyens de mise en mémoire destinés à mettre en mémoire à l'avance la quantité de carburant de base déterminée en fonction de l'état de fonctionnement du moteur et un capteur du rapport air/carburant qui est prévu dans le passage d'échappement du moteur afin de mesurer le rapport air/carburant du gaz d'échappement qui s'écoule dans le passage d'échappement, lesdits moyens de contrôle du rapport air/carburant étant aptes à corriger la quantité de carburant de base, de telle sorte que le rapport air/carburant du gaz d'échappement devienne le rapport air/carburant de consigne, par un coefficient de correction à rétroaction qui varie en fonction du signal de sortie dudit capteur de rapport air/carburant.
12. Un dispositif d'épuration du gaz d'échappement d'un moteur à combustion interne selon la revendication 11, dans lequel lesdits moyens de contrôle du rapport air/carburant sont aptes à corriger la quantité de carburant de base, de telle sorte que le rapport air/carburant du gaz d'échappement devienne le rapport air/carburant de consigne, par le coefficient de correction à rétroaction, lorsque le NO_x doit être absorbé dans l'absorbant de NO_x et, en même temps, à corriger ledit coefficient de correction à rétroaction par un coefficient d'apprentissage de telle sorte que ledit coefficient de correction à rétroaction fluctue autour d'une valeur de référence, et dans lequel lesdits moyens de contrôle du rapport air/carburant sont aptes à fixer la valeur de la correction à rétroaction à ladite valeur de référence lorsque le NO_x doit être libéré de l'absorbant de NO_x et, en même temps, à déterminer la quantité de carburant à fournir au moteur sur la base du coefficient d'apprentissage et de la quantité de carburant de base.
13. Un dispositif d'épuration du gaz d'échappement d'un moteur à combustion interne selon la revendication 7, dans lequel le moteur à combustion interne comprend un moteur diesel équipé d'un injecteur de carburant pour injecter du carburant dans la chambre de combustion et d'une soupape d'étranglement disposée dans le passage d'admission du

- moteur; et lesdits moyens de contrôle du rapport air/carburant sont aptes à contrôler l'absorption de NO_x dans l'absorbant de NO_x et la libération de NO_x de l'absorbant de NO_x par contrôle de la quantité de carburant à injecter par l'injecteur et du degré d'ouverture de la soupape d'étranglement.
14. Un dispositif d'épuration du gaz d'échappement d'un moteur à combustion interne selon la revendication 13, dans lequel lesdits moyens de contrôle du rapport air/carburant sont aptes à augmenter la quantité à injecter et pour diminuer le degré d'ouverture de la soupape d'étranglement lorsque le NO_x doit être libéré de l'absorbant de NO_x.
15. Un dispositif d'épuration du gaz d'échappement d'un moteur à combustion interne selon la revendication 1, comprenant en outre des moyens de contrôle du rapport air/carburant destinés à contrôler le rapport air/carburant du gaz d'échappement rejeté de la chambre de combustion du moteur et s'écoulant dans l'absorbant de NO_x disposé dans le passage d'échappement du moteur, et l'absorption de NO_x dans l'absorbant de NO_x et la libération de NO_x de l'absorbant de NO_x pouvant d'être contrôlés en contrôlant le rapport air/carburant du gaz d'échappement qui s'écoule dans l'absorbant de NO_x à l'aide desdits moyens de contrôle du rapport.
16. Un dispositif d'épuration du gaz d'échappement d'un moteur à combustion interne selon la revendication 15, dans lequel lesdits moyens de contrôle du rapport air/carburant sont aptes à rendre pauvre le rapport air/carburant du gaz d'échappement qui s'écoule dans l'absorbant de NO_x lorsque le NO_x doit être absorbé dans l'absorbant de NO_x, et à rendre le rapport air/carburant du gaz d'échappement s'écoulant dans l'absorbant de NO_x égal au rapport air/carburant stoechiométrique ou riche lorsque le NO_x doit être libéré de l'absorbant de NO_x.
17. Un dispositif d'épuration du gaz d'échappement d'un moteur à combustion interne selon la revendication 16, dans lequel lesdits moyens de contrôle du rapport air/carburant sont aptes à fournir un agent réducteur à l'intérieur du passage d'échappement du moteur lorsque le NO_x doit être libéré de l'absorbant de NO_x.
18. Un dispositif d'épuration du gaz d'échappement d'un moteur à combustion interne selon la revendication 17, dans lequel ledit agent réducteur est constitué par un hydrocarbure.
19. Un dispositif d'épuration du gaz d'échappement d'un moteur à combustion interne selon la revendication 18, dans lequel ledit hydrocarbure comprend au moins un élément choisi parmi l'essence, l'isooctane, l'hexane, l'heptane, le butane, le propane, l'huile légère et le kérosène.
20. Un dispositif d'épuration du gaz d'échappement d'un moteur à combustion interne selon la revendication 1, comprenant en outre des moyens de contrôle de la libération de NO_x qui sont appropriés pour réduire la concentration en oxygène du gaz d'échappement qui s'écoule dans l'absorbant de NO_x seulement pendant une seconde période fixe, déterminée au préalable de manière à libérer le NO_x de l'absorbant de NO_x lorsque la période pendant laquelle le rapport air/carburant du gaz d'échappement qui s'écoule dans l'absorbant de NO_x est rendu pauvre et le NO_x est absorbé dans l'absorbant de NO_x, dépasse une première période fixe déterminée au préalable.
21. Un dispositif d'épuration du gaz d'échappement d'un moteur à combustion interne selon la revendication 20, dans lequel lesdits moyens de contrôle de la libération de NO_x sont aptes à rendre le rapport air/carburant du gaz d'échappement qui s'écoule dans l'absorbant de NO_x égal au rapport air/carburant stoechiométrique ou riche lorsque le NO_x doit être libéré de l'absorbant de NO_x.
22. Un dispositif d'épuration du gaz d'échappement d'un moteur à combustion interne selon la revendication 20, dans lequel lesdits moyens de contrôle de la libération de NO_x sont dotés de moyens d'estimation de la quantité de NO_x absorbée dans l'absorbant de NO_x, et lesdits moyens de contrôle de la libération de NO_x sont aptes à décider que ladite première période fixe s'est écoulée lorsque la quantité de NO_x estimée par les moyens d'estimation de la quantité de NO_x dépasse une quantité fixe déterminée au préalable.
23. Un dispositif d'épuration du gaz d'échappement d'un moteur à combustion interne selon la revendication 22, dans lequel lesdits moyens d'estimation de la quantité de NO_x sont aptes à décider que la quantité de NO_x absorbée dans l'absorbant de NO_x dépasse ladite quantité fixée lorsqu'une valeur cumulée d'une vitesse du moteur dépasse une valeur fixe déterminée au préalable.
24. Un dispositif d'épuration du gaz d'échappement d'un moteur à combustion interne selon la revendication 22, dans lequel lesdits moyens d'estimation de la quantité de NO_x sont aptes à décider si le NO_x absorbé dans l'absorbant de NO_x a été libéré sensiblement en totalité lorsque le rapport air/carburant du mélange air/carburant formé dans la chambre de combustion du moteur est maintenu au niveau du rapport air/carburant stoechiométrique ou est riche pendant une durée prédéterminée ou plus long-

temps.

- 25.** Un dispositif d'épuration du gaz d'échappement d'un moteur à combustion interne selon la revendication 20, dans lequel ladite seconde durée fixée est sensiblement inférieure à 20 secondes. 5
- 26.** Un dispositif d'épuration du gaz d'échappement d'un moteur à combustion interne selon la revendication 20, dans lequel lesdits moyens de contrôle de la libération de NO_x sont munis d'un capteur de température afin de mesurer la température du gaz d'échappement qui s'écoule dans l'absorbant de NO_x , et lesdits moyens de contrôle de la libération de NO_x sont munis de moyens d'interdiction qui interdisent la diminution de la concentration en oxygène du gaz d'échappement qui s'écoule dans l'absorbant de NO_x même si la période pendant laquelle le NO_x est absorbé dans l'absorbant de NO_x dépasse ladite première période fixée, lorsque la température du gaz d'échappement qui s'écoule dans l'absorbant de NO_x devient inférieure à une température limite pour laquelle le NO_x peut être absorbé par l'absorbant de NO_x . 10
15
20
25
- 27.** Un dispositif d'épuration du gaz d'échappement d'un moteur à combustion interne selon la revendication 26, dans lequel lesdits moyens de contrôle de la libération de NO_x sont aptes à diminuer immédiatement la concentration en oxygène du gaz d'échappement qui s'écoule dans l'absorbant de NO_x lorsque la température du gaz d'échappement qui s'écoule dans l'absorbant de NO_x devient supérieure à ladite température limite après que la concentration en oxygène du gaz d'échappement qui s'écoule dans l'absorbant de NO_x ait été diminuée par lesdits moyens d'interdiction. 30
35
- 28.** Un dispositif d'épuration du gaz d'échappement d'un moteur à combustion interne selon la revendication 1, dans lequel un autre catalyseur capable de réduire au moins le NO_x est disposé dans le passage d'échappement du moteur, en aval de l'absorbant de NO_x . 40
45
- 29.** Un dispositif d'épuration du gaz d'échappement d'un moteur à combustion interne selon la revendication 28, dans lequel ledit catalyseur comprend un catalyseur à trois voies. 50
- 30.** Un dispositif d'épuration du gaz d'échappement d'un moteur à combustion interne selon la revendication 1, dans lequel un autre catalyseur capable de purifier la quantité de HC et de CO non brûlés, est disposé dans le passage d'échappement du moteur, en amont de l'absorbant de NO_x . 55
- 31.** Un dispositif d'épuration du gaz d'échappement

d'un moteur à combustion interne selon la revendication 30, dans lequel ledit catalyseur comprend un catalyseur à trois voies.

Fig. 1

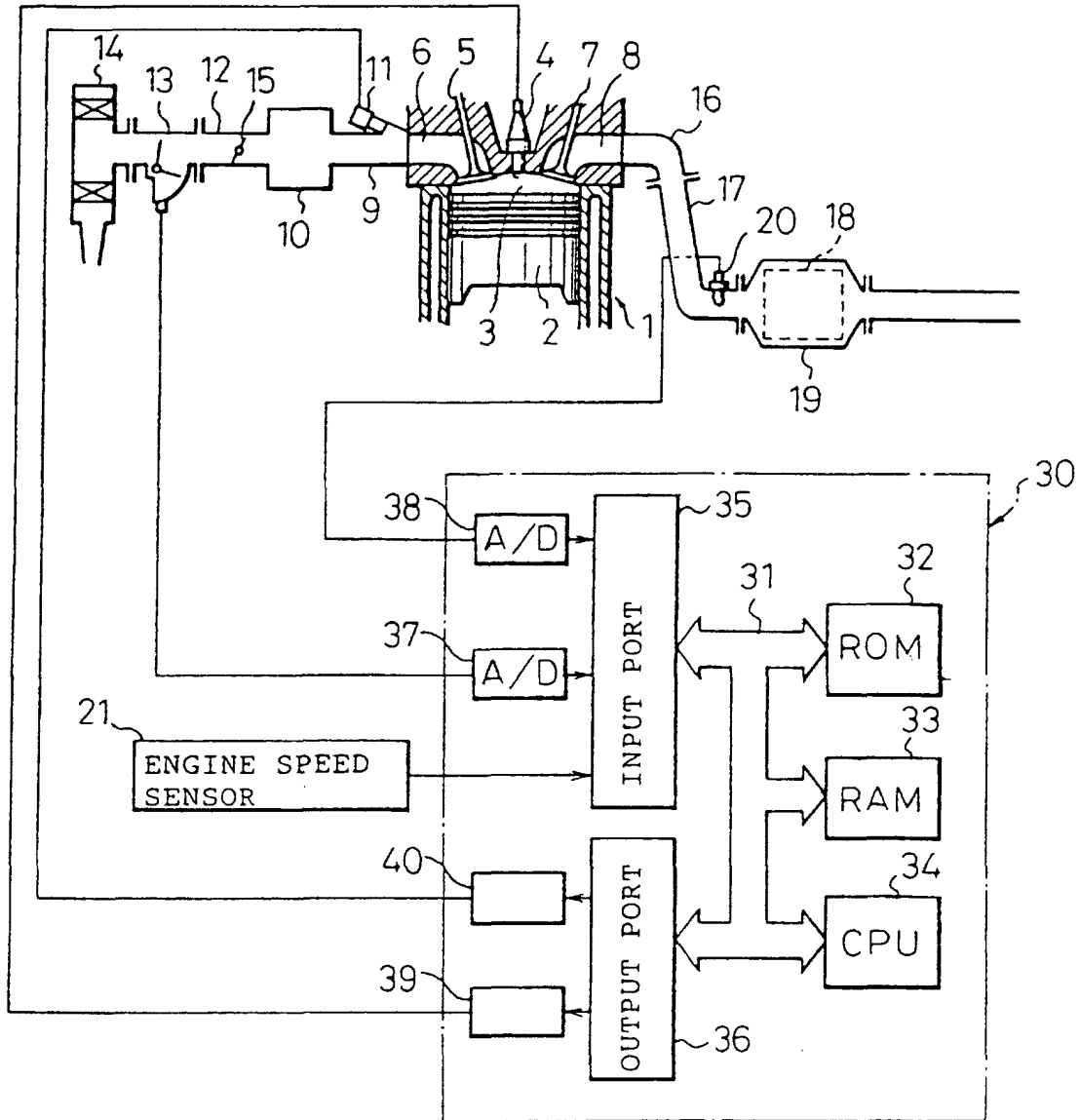

Fig. 2

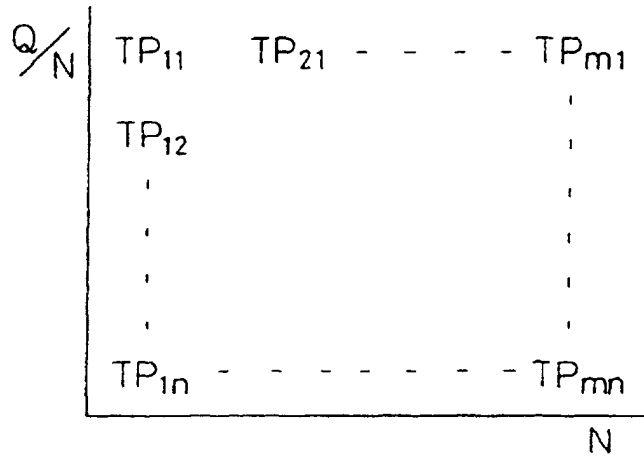

Fig. 3

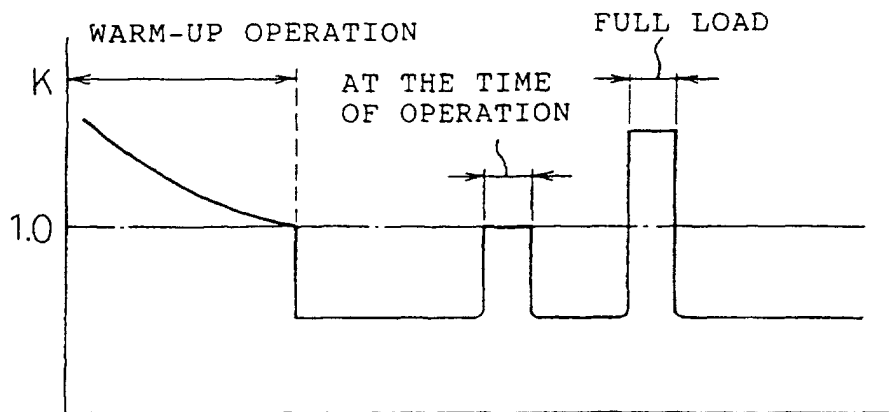

Fig. 4

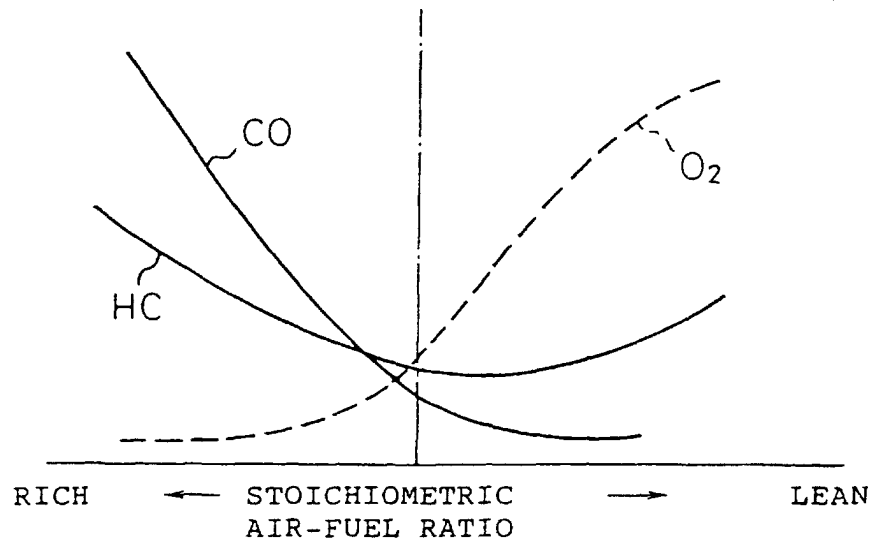

Fig. 5(A)

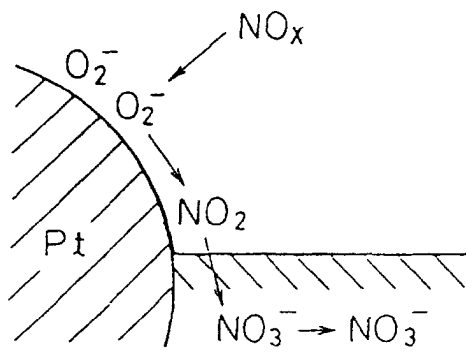

Fig. 5(B)

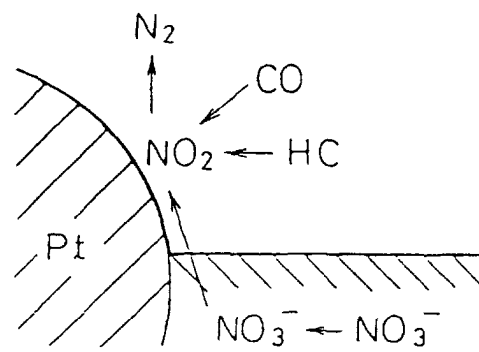

Fig. 6

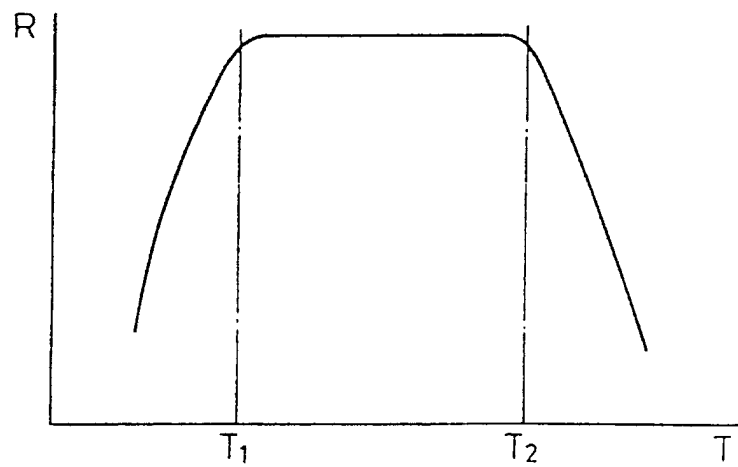

Fig. 7(A)

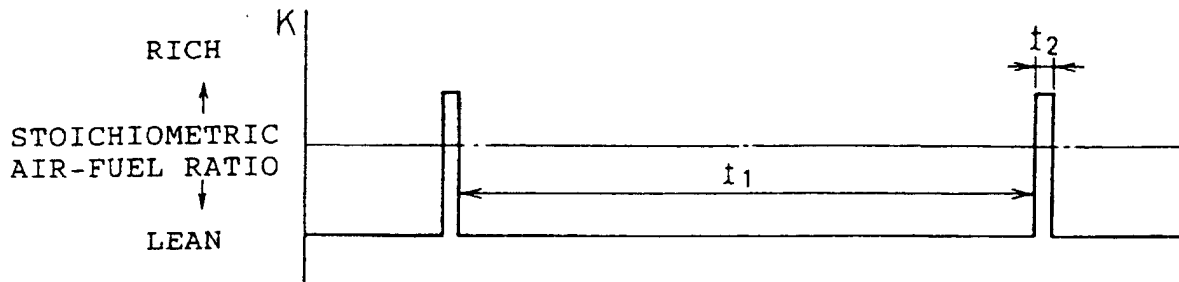

Fig. 7(B)

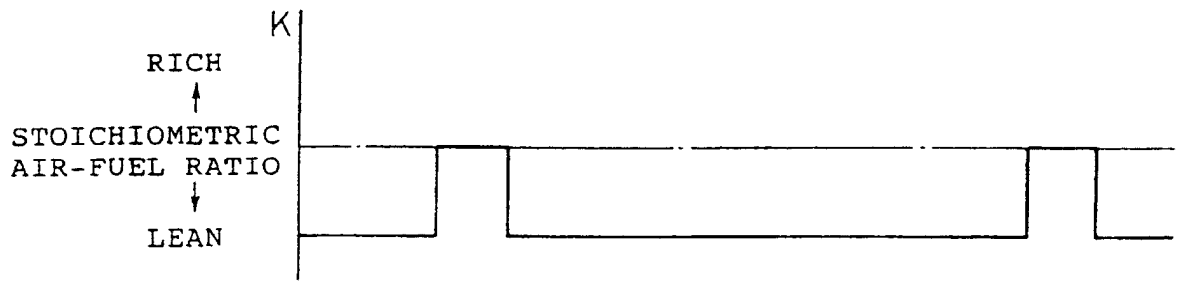

Fig. 7(C)

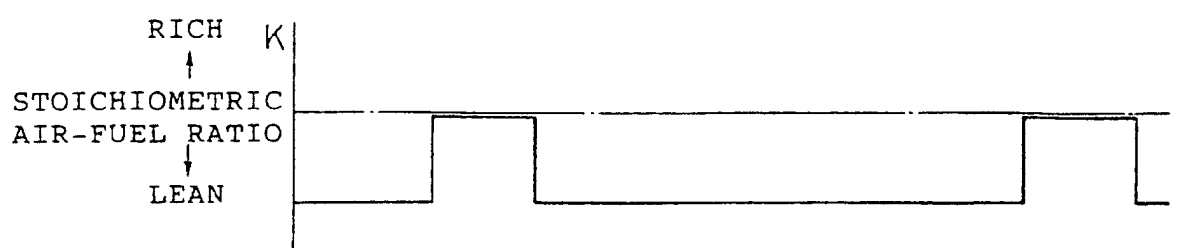

Fig. 8

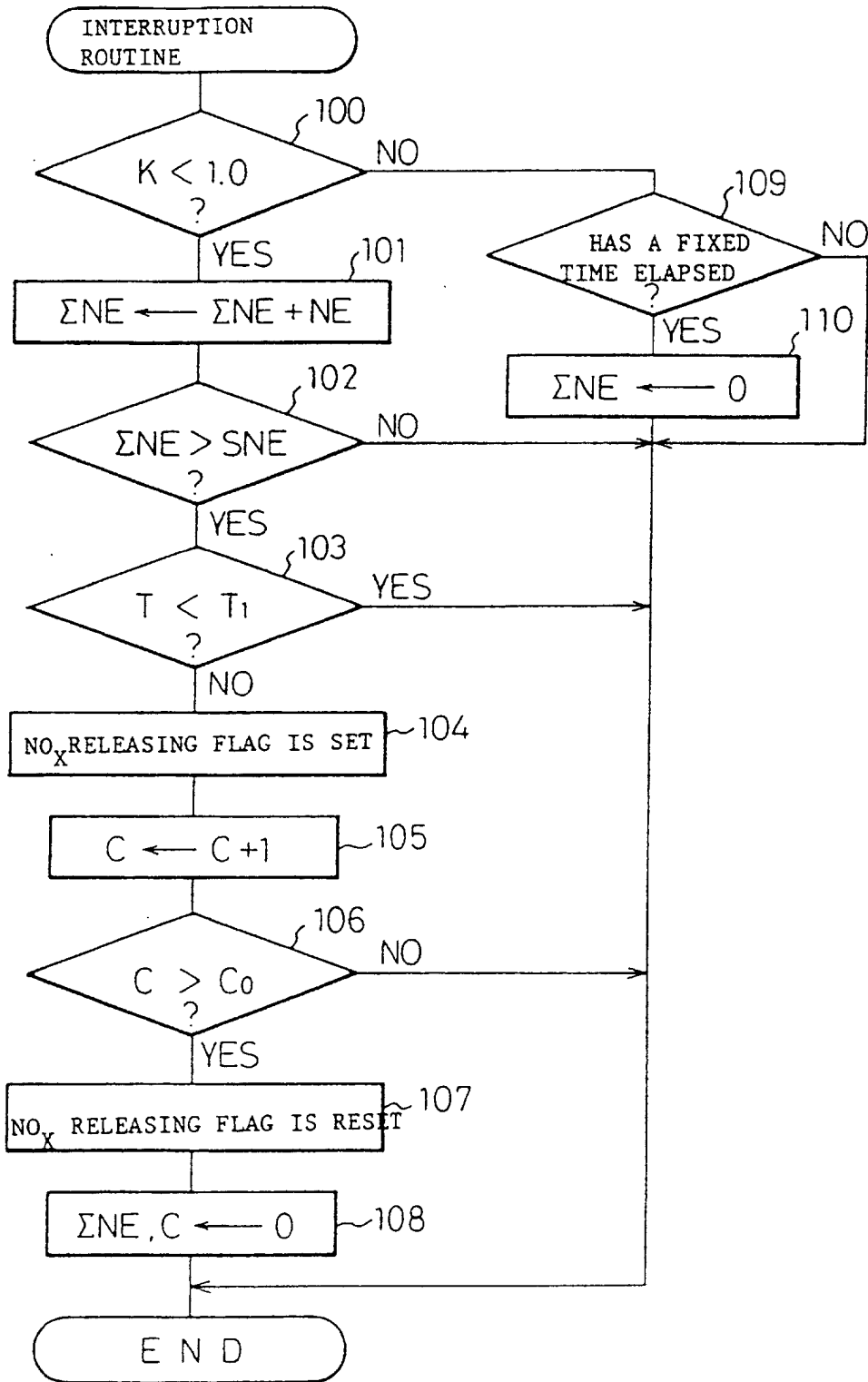

Fig.9

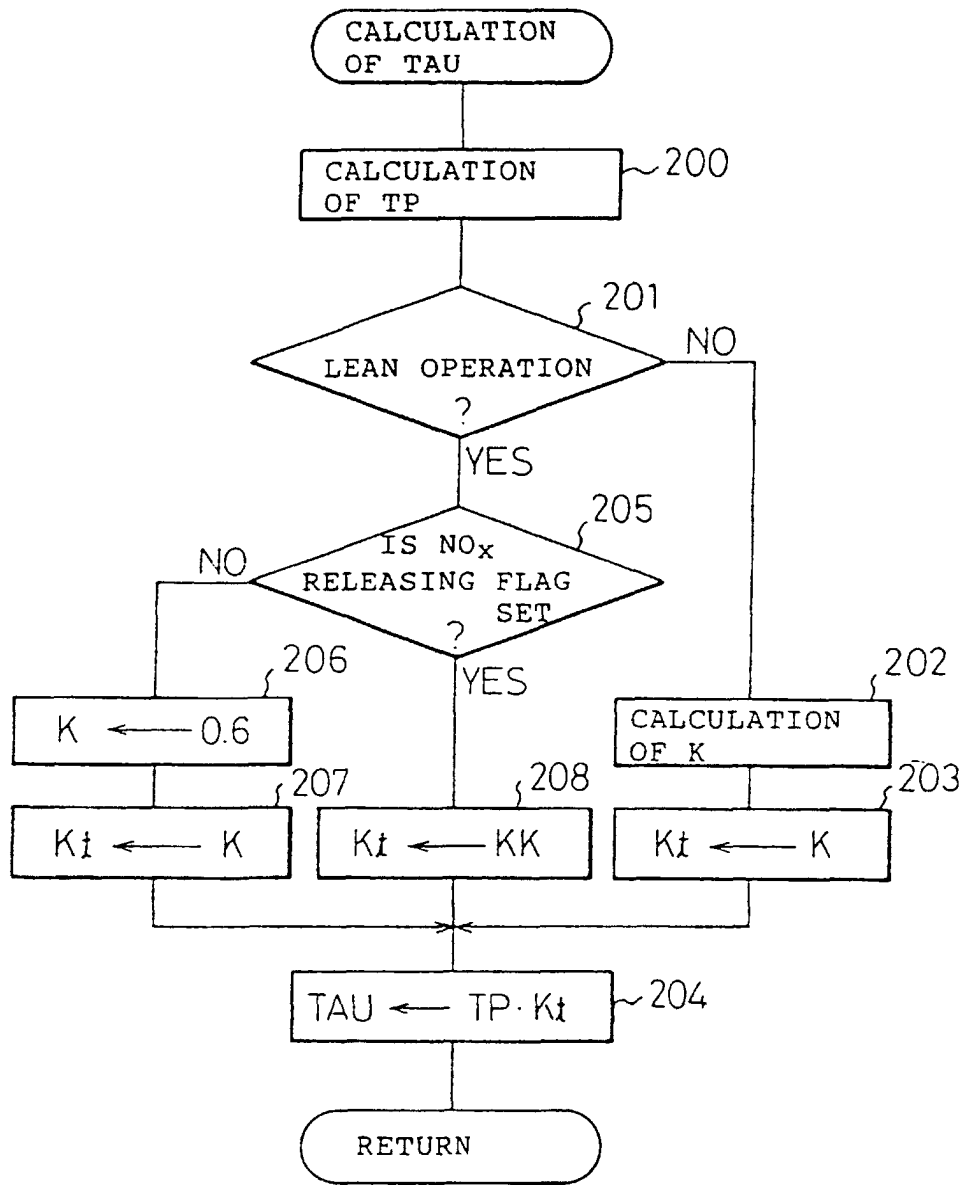

Fig.10

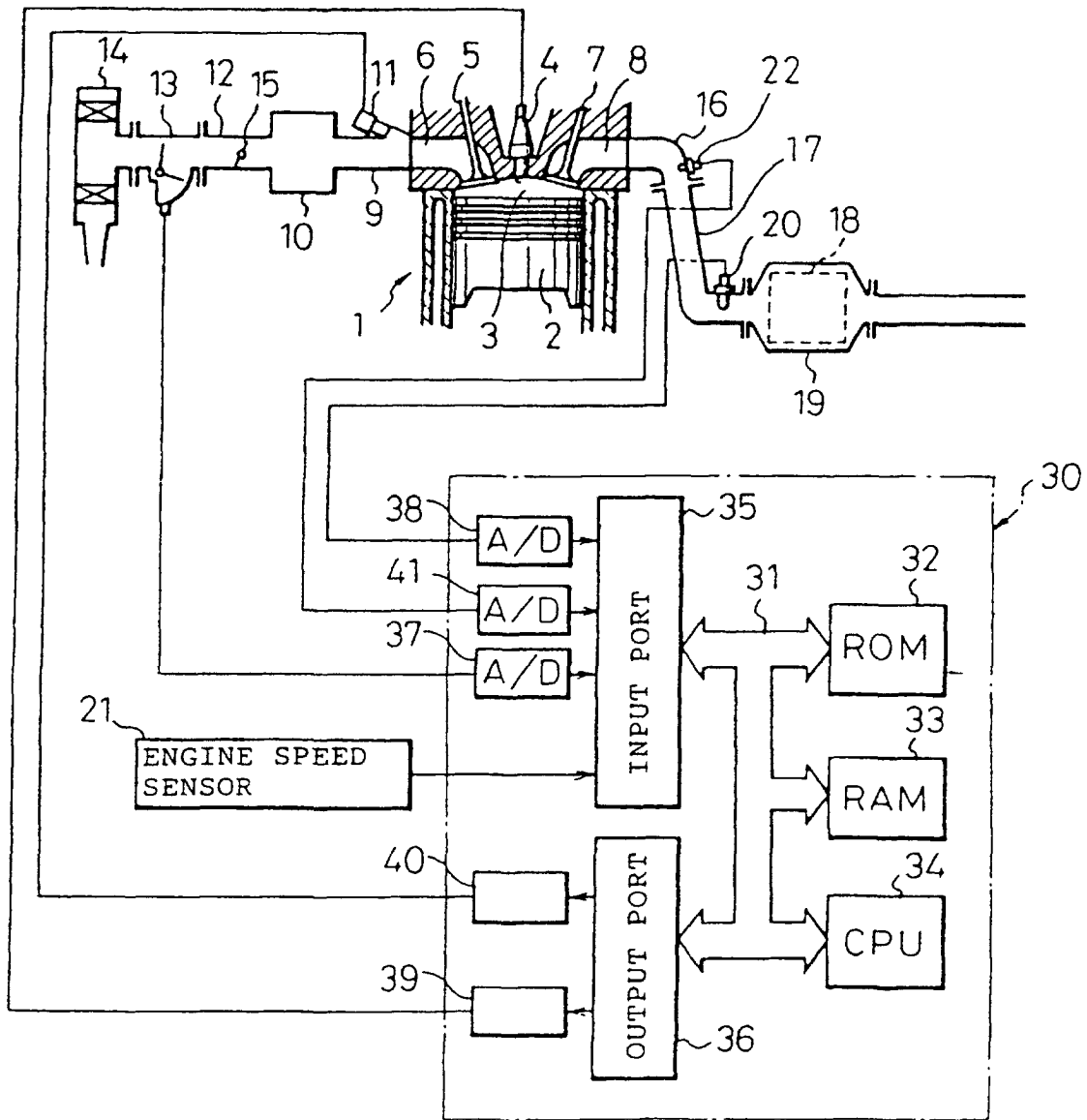

Fig.11

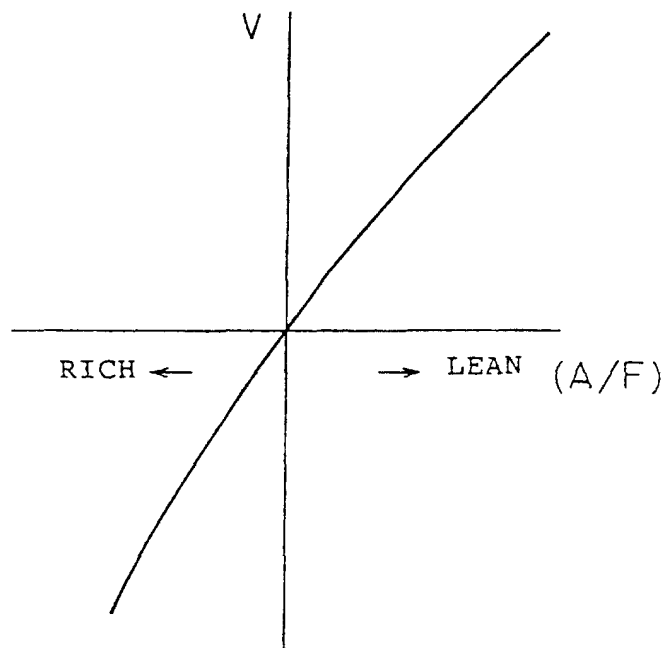

Fig.12

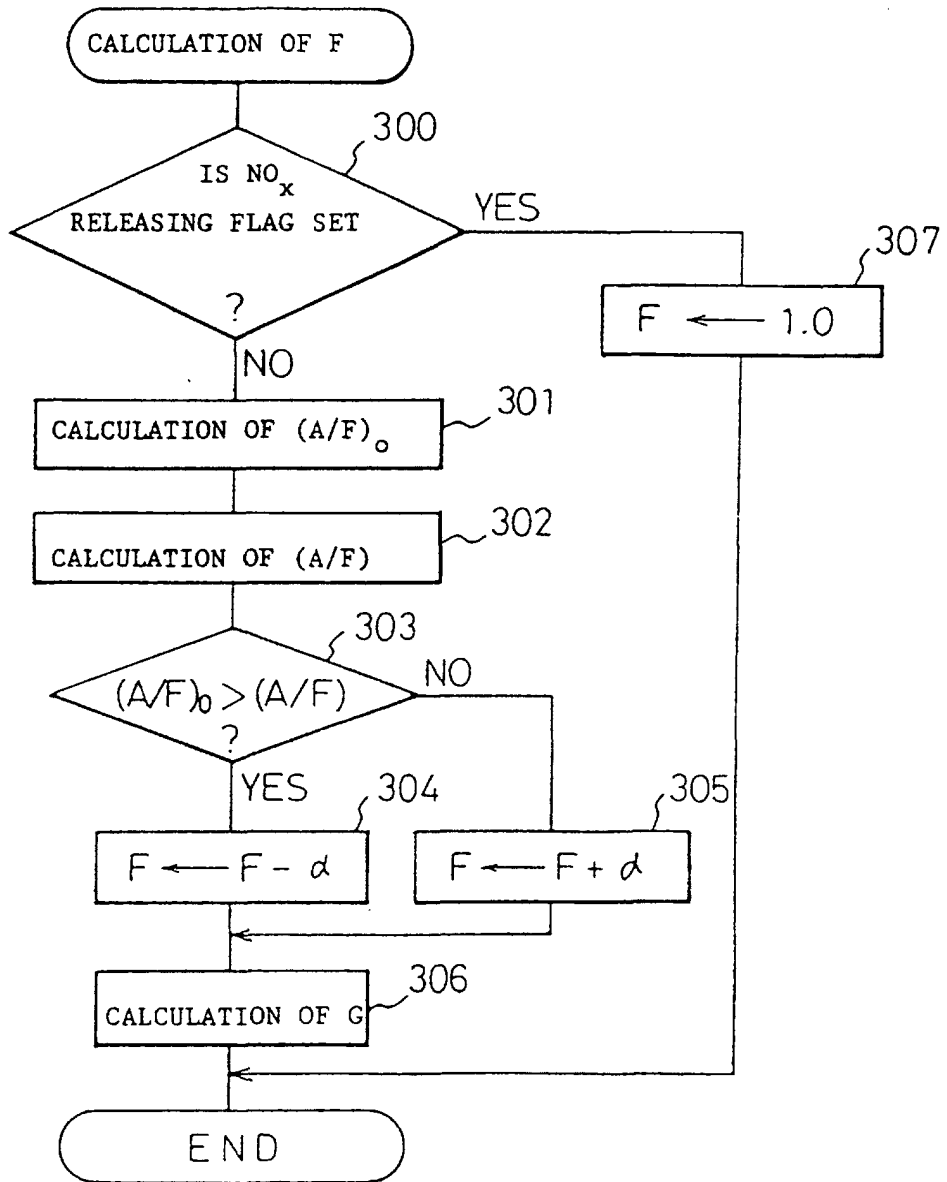

Fig.13

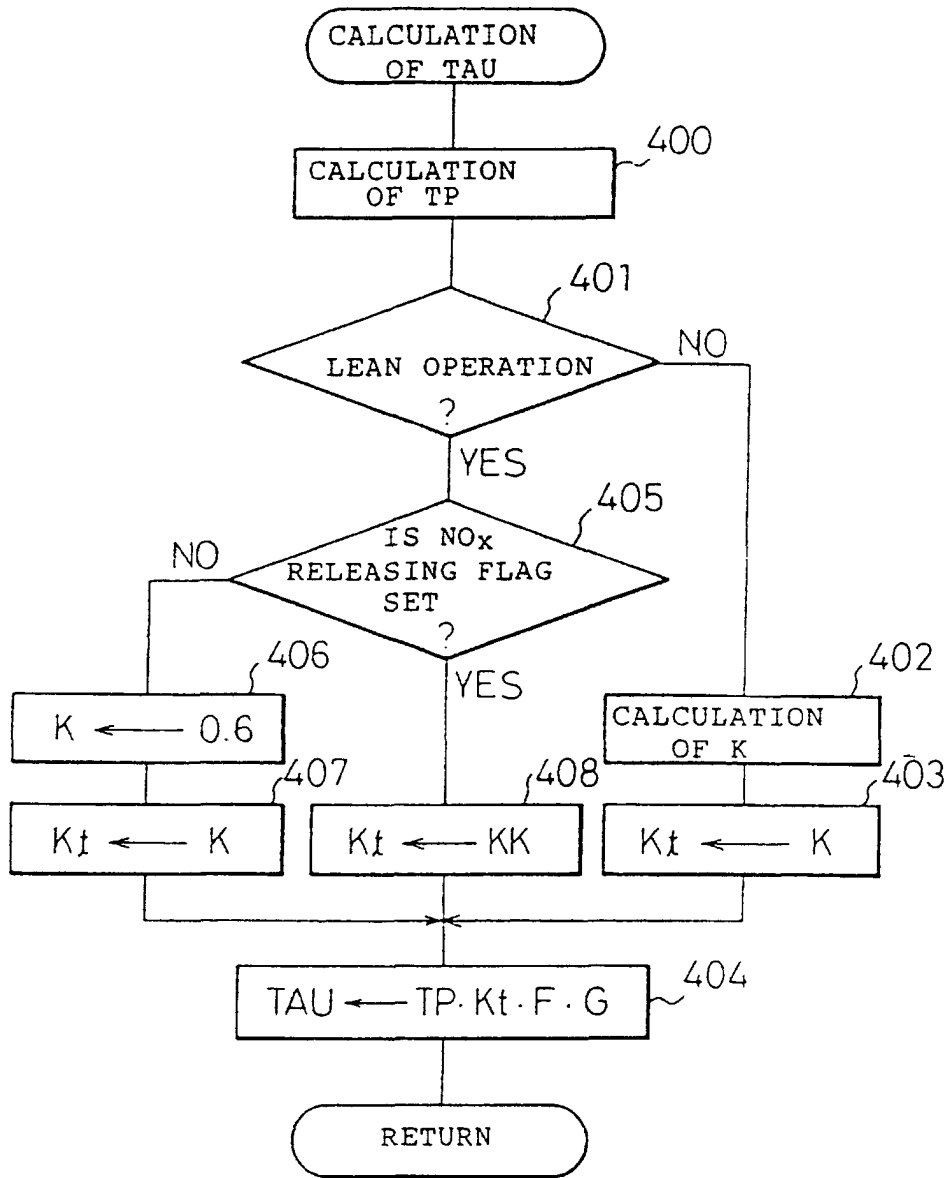

Fig. 14

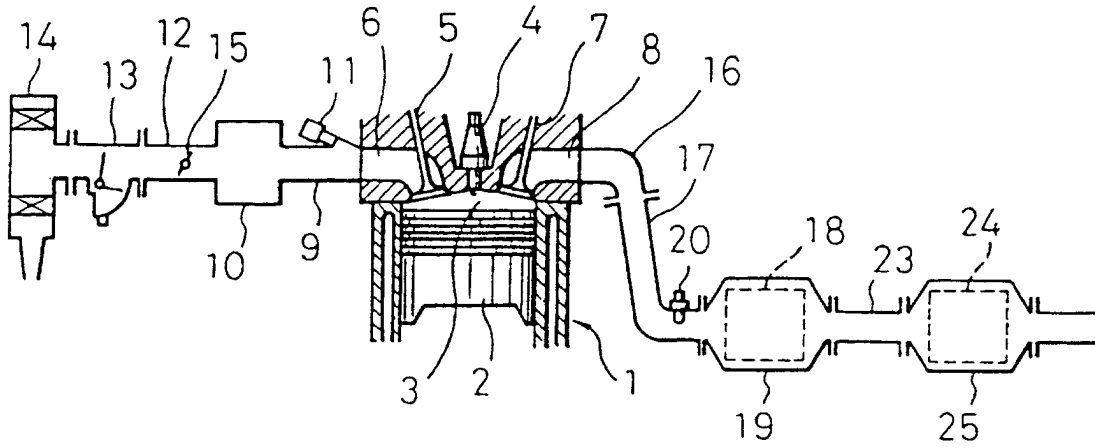

Fig. 15

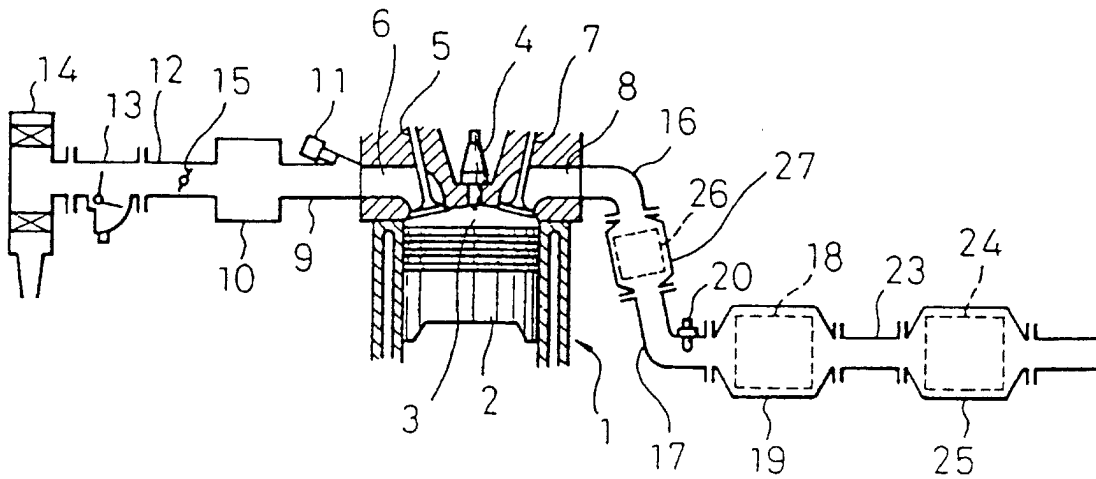

Fig.16

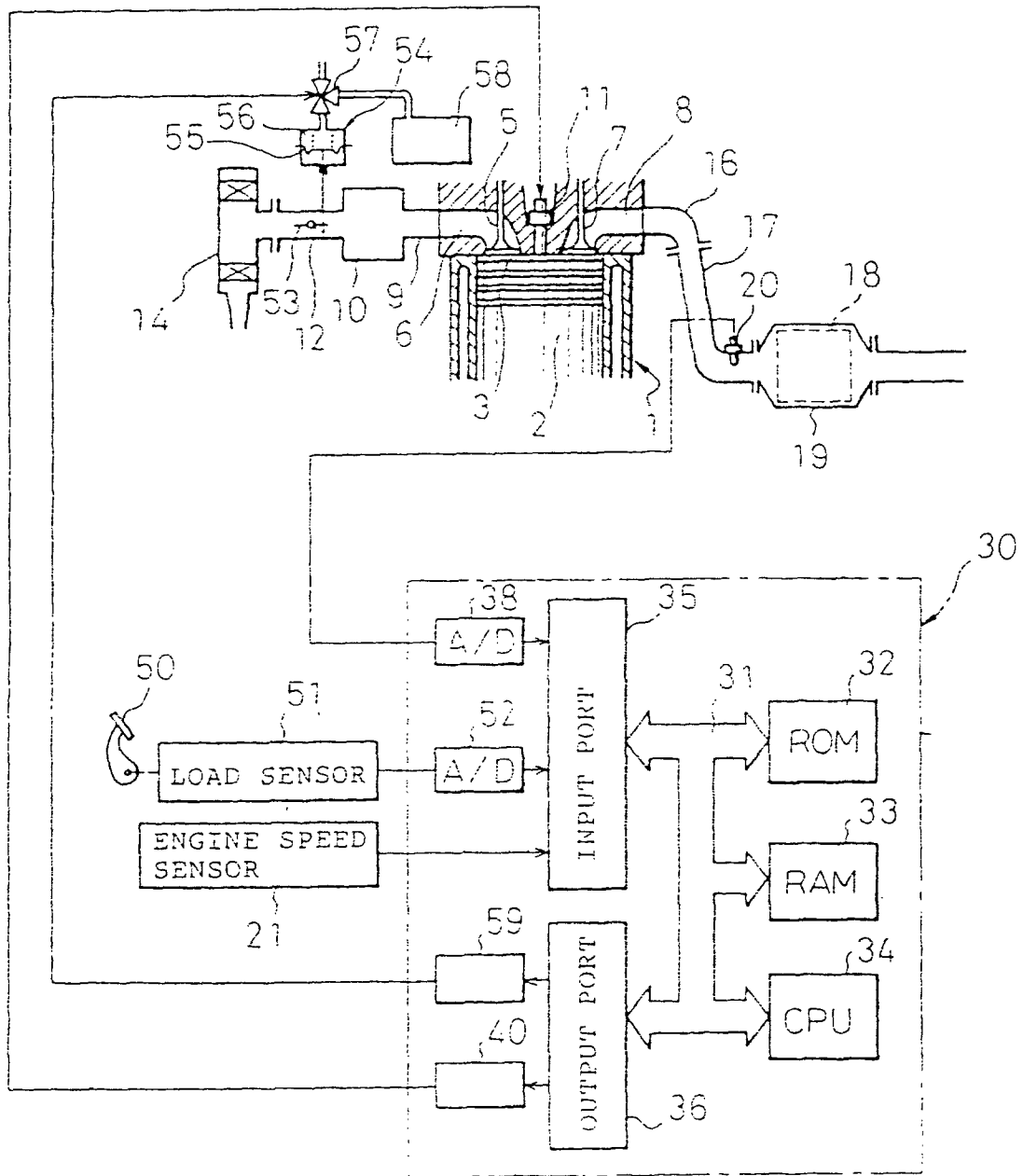

Fig.17

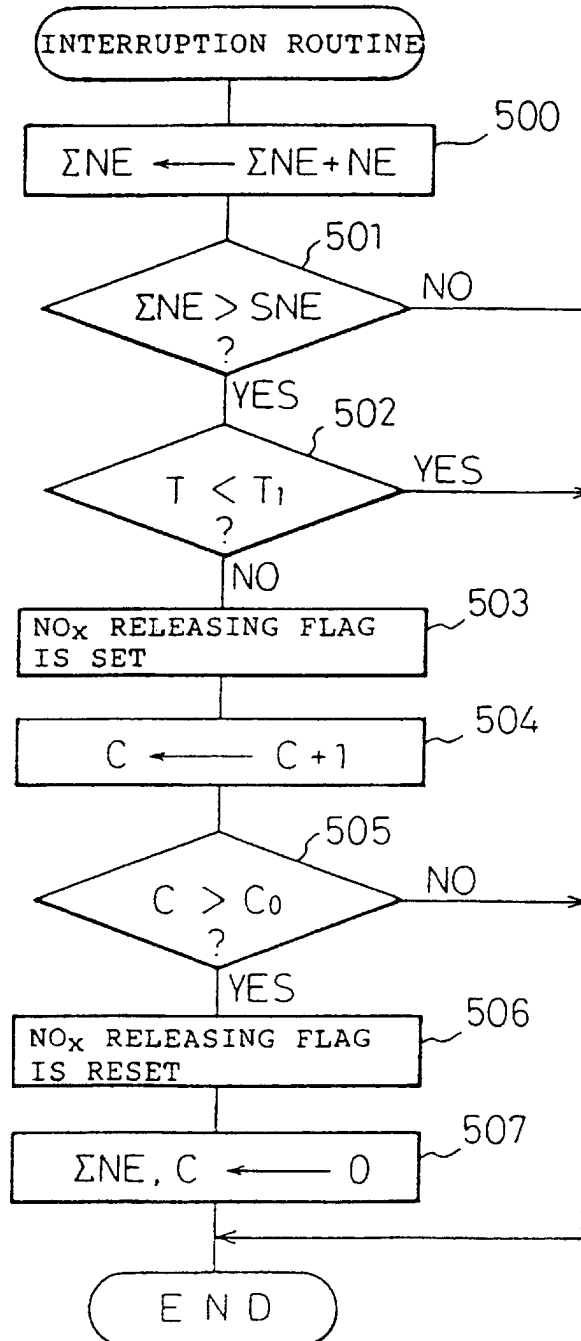

Fig.18

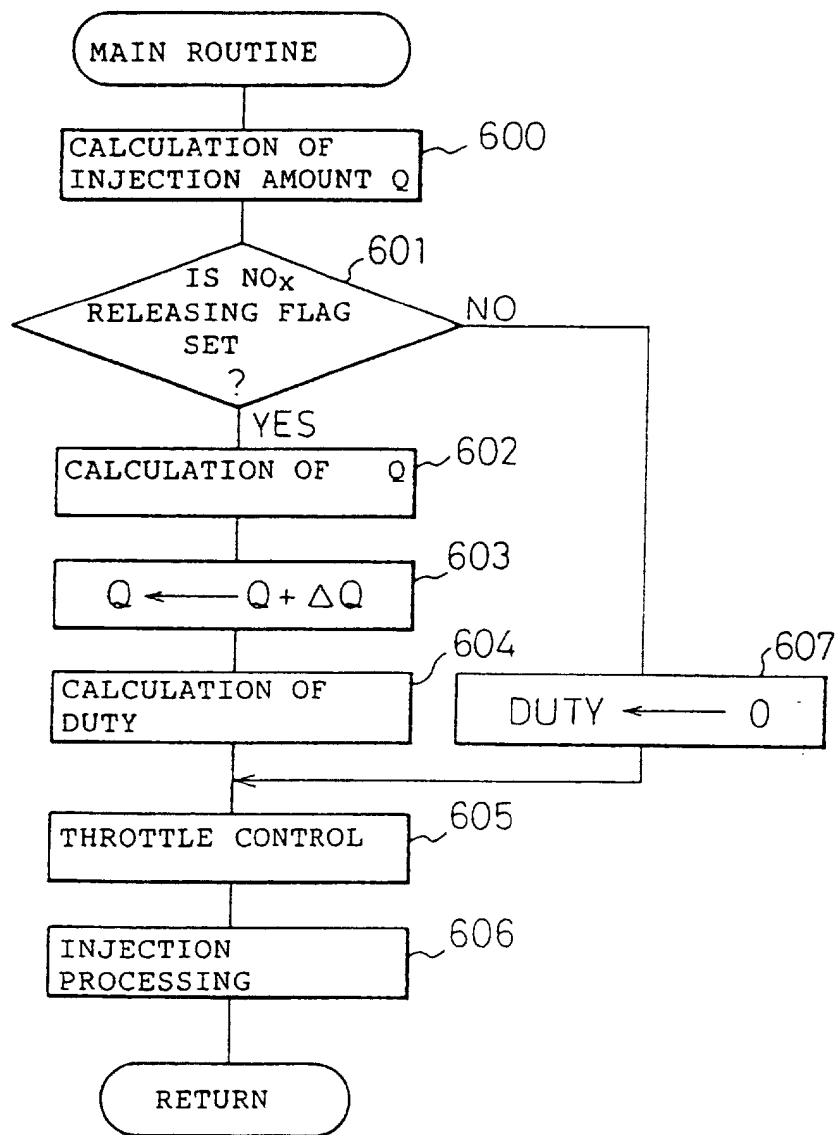

Fig. 19

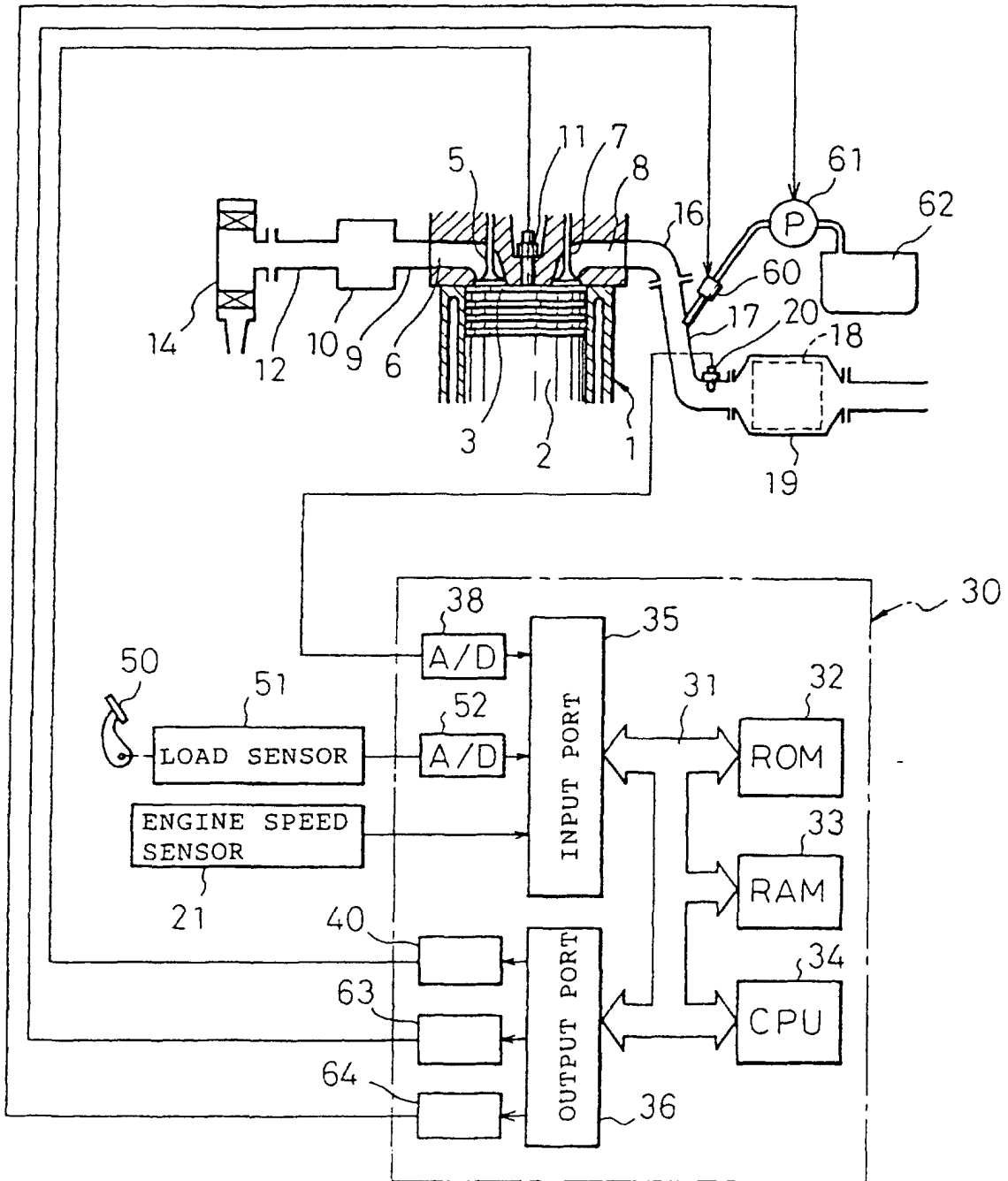

Fig. 20

