

(19) World Intellectual Property Organization
International Bureau



(43) International Publication Date
13 November 2003 (13.11.2003)

PCT

(10) International Publication Number
WO 03/092786 A1

- (51) International Patent Classification⁷: A61M 39/00, 39/04, A61J 1/00
- (21) International Application Number: PCT/US03/12704
- (22) International Filing Date: 25 April 2003 (25.04.2003)
- (25) Filing Language: English
- (26) Publication Language: English
- (30) Priority Data:
10/136,994 1 May 2002 (01.05.2002) US
- (71) Applicant: BECTON DICKINSON AND COMPANY [US/US]; 1 Becton Drive, Franklin Lakes, NJ 07417-1880 (US).
- (72) Inventors: CHRISTENSEN, Kelly, David; 1188 N. Deerfield Drive, Centerville, UT 84014 (US). HARDING, Weston, F.; 2421 North 910 West, Lehi, UT 84043 (US). SONDEREGGER, Ralph, L.; 1671 W. 1440 North, Farmington, UT 84025 (US). BROWN, Carolyn, Elizabeth; 1333 South 200 East, Salt Lake City, UT 84115 (US). MOULTON, William, Gary; 3026 W. 7050 South, West Jordan, UT 84084 (US). BRIMHALL, Greg, L.; 3838 Valley West Drive, West Jordan, UT 84088 (US).
- (74) Agent: MURTHA, James, J.; Becton, Dickinson and Company, 1 Becton Drive, Franklin Lakes, NJ 07417-1880 (US).
- (81) Designated States (national): AE, AG, AL, AM, AT, AU, AZ, BA, BB, BG, BR, BY, BZ, CA, CH, CN, CO, CR, CU, CZ, DE, DK, DM, DZ, EC, EE, ES, FI, GB, GD, GE, GH, GM, HR, HU, ID, IL, IN, IS, JP, KE, KG, KP, KR, KZ, LC, LK, LR, LS, LT, LU, LV, MA, MD, MG, MK, MN, MW, MX, MZ, NO, NZ, OM, PH, PL, PT, RO, RU, SC, SD, SE, SG, SK, SL, TJ, TM, TN, TR, TT, TZ, UA, UG, UZ, VC, VN, YU, ZA, ZM, ZW.
- (84) Designated States (regional): ARIPO patent (GH, GM, KE, LS, MW, MZ, SD, SL, SZ, TZ, UG, ZM, ZW),

[Continued on next page]

(54) Title: NEEDLELESS LUER ACCESS CONNECTOR

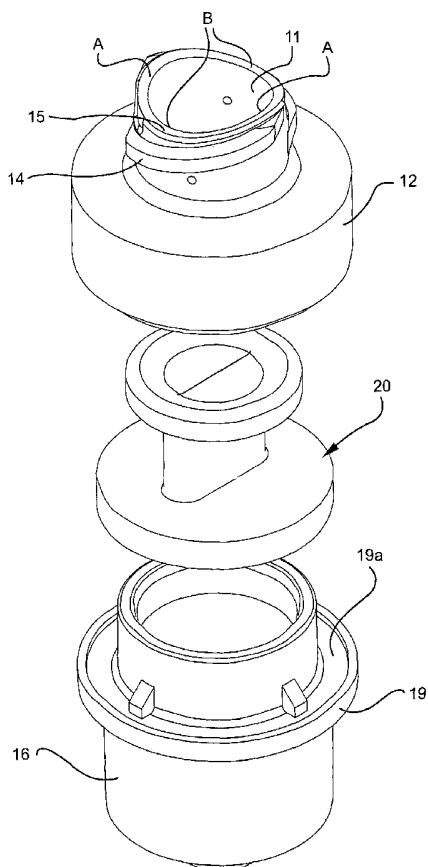

(57) Abstract: A needleless luer access connector is disclosed having a septum (20) disposed in a housing (10). The septum (20) has a proximal portion (21) with a cross section, a medial portion (22) with a cross section smaller than the cross section of the proximal portion (12), and a distal portion (23). A longitudinal slit (25) extends through the septum (20) from the proximal portion (21) to the distal portion (23). The septum (20) and housing (10) are designed so that septum (20) will not be rotated or removed from the housing (10) when the connector is accessed by a male luer taper. In addition, the septum (20) and housing (10) are designed to bias the slit (25) at the distal portion (23) closed and so a male luer connector does not have to extend completely through the distal portion (23) to open the slit (25) at the distal portion (23). Finally, the septum (20) and housing (10) are designed to minimize the amount of dead space in the connector when accessed with a male luer taper.



WO 03/092786 A1



Eurasian patent (AM, AZ, BY, KG, KZ, MD, RU, TJ, TM),
European patent (AT, BE, BG, CH, CY, CZ, DE, DK, EE,
ES, FI, FR, GB, GR, HU, IE, IT, LU, MC, NL, PT, RO,
SE, SI, SK, TR), OAPI patent (BF, BJ, CF, CG, CI, CM,
GA, GN, GQ, GW, ML, MR, NE, SN, TD, TG).

For two-letter codes and other abbreviations, refer to the "Guidance Notes on Codes and Abbreviations" appearing at the beginning of each regular issue of the PCT Gazette.

Published:

— *with international search report*

NEEDLELESS LUER ACCESS CONNECTOR

5 Inventors: K. Christensen; W. Harding; T. Miner; C. Brown; W. Moulton; G. Brimhall

Background of the Invention

10 [0001] The subject invention relates to a needleless connector referred to generally as a luer access device that allows a clinician to access a fluid flow line without the use of sharp needles. More particularly, the subject invention relates to a needleless luer access connector that may be opened by a standard male luer taper of a medical device, such as a syringe. The penetration of the connector by the male luer taper allows fluid flow through the connector. When the male luer taper is removed
15 from the connector, it closes to prevent fluid flow therethrough.

[0002] In the treatment of patients, fluids are transferred between various containers and intravascular (IV) lines or through IV catheters into the patient through a closed system to prevent microbial ingress to the patient. During the course of such treatment where an IV catheter has been placed into a patient to gain access to the
20 patient's vasculature, it may be necessary to infuse other fluids, such as medicaments, through the catheter into the patient or to withdraw blood from the patient for blood gas or other analysis. Such fluid withdrawal or injection into a patient may be through IV lines, saline wells, arterial lines, or hemodialysis lines. Previously, a rubber or silicone septum was used to cover an opening in the catheter or the IV line to prevent fluid from
25 flowing out of the opening and to maintain a closed system. A clinician could access the opening by inserting a sharp needle from a syringe through the septum. This allowed the clinician to infuse fluid from the syringe into the patient or withdraw fluid from the patient into the syringe. The septum would reseal after the needle was withdrawn to prevent back flow of the fluid.

30 [0003] In recent years, there has been great concern over the contamination of clinicians with a patient's blood or other fluid and a recognition that such "blood contaminated sharps" must be immediately disposed. This concern has arisen because of the advent of currently incurable and fatal diseases, such as Acquired Immune Deficiency Syndrome ("AIDS") and hepatitis, which can be transmitted by the
35 exchange of body fluids from an infected person to another person. Thus, contact with the body fluid of an AIDS or hepatitis infected person must be avoided to prevent the

transmission of such diseases to a healthy person. If a needle has been used to access an IV line in communication with an AIDS- or hepatitis-infected person, the needle is a vehicle for the transmission of the disease. Although clinicians are aware of the need to properly handle "blood contaminated sharps," unfortunately in certain medical environments, such as emergency situations or as a result of inattention or neglect, 5 needlesticks with contaminated needles still occur. As a result of the problem of accidental needlesticks by "blood contaminated sharps," much effort has been expended in developing various connectors that avoid the use of sharp needles.

[0004] One type of needleless connector includes a longitudinally movable diaphragm that controls the flow of fluid through an internal cannula fixed in the connector. This internal cannula defines the fluid flow path through the connector. The movable diaphragm cooperates with a biasing member such as a spring or other flexible member that biases the top of the movable diaphragm toward the inlet or proximal opening to the connector. The opening is typically in the form of a female 15 luer connection. When the movable diaphragm is adjacent to the inlet of the connector, the movable diaphragm occludes the opening to the internal cannula to close the connector to fluid flow. The connector can be opened when the clinician inserts the male luer taper of another medical device, such as a syringe, into the female luer portion of the connector. When this is done, the movable diaphragm is pushed down 20 into the housing so the internal cannula extends through a pre-formed slit in the movable diaphragm providing a fluid flow path through the connector.

[0005] Although such connectors can generally operate in accordance with their intended function, such connectors could be improved. When the tip of the internal cannula engages the movable diaphragm, the internal cannula has a tendency to core 25 the movable diaphragm. This may cause pieces of the movable diaphragm to be broken off and potentially infused into a patient. In addition, this coring of the movable diaphragm promotes fluid leakage of the connector and can result in a pathway for microbial ingress. Finally, the force needed to move the movable diaphragm past the tip of the internal cannula could be quite high making it difficult to operate and 30 resulting in a substantial kickback force that tends to push the male luer taper back out of the connector.

[0006] A potential improvement to connectors with internal cannula are connectors that include a longitudinally movable diaphragm having a molded-in opening through the diaphragm to control the flow of fluid through the connector.

Some biasing member biases the movable diaphragm toward the inlet of the device. In this position, the proximal portion of the movable diaphragm is radially biased by the sidewalls of the housing defining the inlet opening of the connector to bias closed the molded in opening. This prevents fluid flow through the connector. When the clinician
5 inserts the male luer taper of the syringe into the inlet of the connector, the movable diaphragm is moved down into the connector to an area that does not contact the proximal portion of the movable diaphragm. This allows the proximal portion of the diaphragm to return to its unbiased condition with the molded in opening in the open position to provide a fluid flow through the connector. Thus, these connectors do not
10 need an internal cannula to extend through the diaphragm to provide the fluid flow path through the connector.

[0007] However, connectors having a molded in opening are not without problems. For example, the molded in opening in the movable diaphragm may not be tightly closed when in the inlet. This could result in leakage through the connector and
15 provide a path for microbial ingress. In addition, the high activation force and kick back problems are not resolved because of the biasing mechanism that is still used in these types of connectors.

[0008] Yet another approach has been the development of a connector that can be accessed by a blunt cannula that is connected to the standard male luer taper of a
20 standard syringe. Such a connector has a septum having a longitudinal slit extending through it disposed over an opening on a proximal end of the connector. The distal end of the connector includes a standard male luer taper so the connector can be connected to other medical devices and IV lines having a female luer connection. This type of connector cannot be accessed with a standard male luer taper because a standard male
25 luer taper is too large to fit into the space in the opening not already occupied by the septum. Instead this type of connector is accessed by a blunt cannula that is narrower than a standard male luer taper and which can be attached to a standard male luer taper. When the clinician desires to access the medical device or IV line, a blunt cannula is placed on the syringe and is then inserted through the slit in the septum. This places the
30 syringe in fluid communication with the medical device or IV line. After fluid is injected into or withdrawn from the patient, the syringe with the blunt cannula is removed from the septum. Because of the design of the connector, the slit in the septum closes and prevents the backflow of fluid through the device.

[0009] Although slit septum connectors that can be accessed by a blunt cannula work generally in accordance with their intended purpose they could be improved. For example, this type of connector requires that a separate blunt cannula be connected to the male luer taper of another medical device to allow the connector to be accessed.

5 This requires excess inventory problems and adds costs to the health care facility using the connector. Moreover, the blunt cannula typically does not fill up the space in the housing of the connector when it is accessed. This leaves an annular “dead space” cavity in the housing between the sides of the blunt cannula and the inner walls of the housing. Residual blood may be left in this cavity and provide a breeding ground for

10 various germs and microbes and is difficult to flush.

Summary of the Invention

[0010] It is therefore an object of this invention to provide a connector that can be accessed without the use of a needle.

15 [0011] It is another object of this invention to provide a needleless luer access connector that is not prone to leakage or microbial ingress.

[0012] It is yet another object of this invention to provide a needleless luer access connector that minimizes the dead space volume therein.

20 [0013] It is still another object of this invention to provide a needleless luer access connector that does not require a high degree of force to access and minimizes the kickback force when the connector is accessed.

[0014] It is a further object of this invention to provide a needleless luer access connector that does not require any additional or special devices to access.

25 [0015] The needleless luer access connector of this invention includes a housing having a top portion and bottom portion with an inlet at the top of the top portion of the connector and an outlet at the bottom of the bottom portion of the connector. The inlet and top portion are designed and configured so that the needleless luer access connector of this invention can be connected to a standard male luer taper configuration of another medical device. Similarly, the outlet and bottom portion has a standard male

30 luer configuration that can be connected to a standard female luer configuration of another medical device. The top portion may be formed, at least in part, by leaf springs. A septum is located in the top portion of the connector to control fluid flow through the connector. The septum has an enlarged proximal portion, a narrowed elongated medial portion and an enlarged distal portion. An adhesive may be employed

to secure the septum in position on the housing. The configuration of the narrowed elongated medial portion allows the needleless luer access connector of this invention to be accessed with a standard male luer taper. It is also designed to minimize both access and kickback force. A longitudinal slit is formed in the septum and extends
5 through the proximal, medial and distal portions thereof. The transverse axis of the slit is preferably parallel to the major axis of the medial portion. The proximal portion of the septum projects above the top of the inlet and rests on the top surface of the sidewalls of the housing located at the periphery of the inlet. Preferably, the top surface has two diametrically opposed high portions and two diametrically opposed low
10 points to give the proximal portion of the septum a saddle-like configuration. This saddle-like configuration biases the slit closed along the proximal portion of the septum. This mechanism ensures a tight seal to prevent leakage and microbial ingress. A lip may be provided about the top surface, circumscribing the proximal portion of the septum and, in certain applications, biasing the proximal portion inward, further
15 tightening the seal of the slit. When the top portion of the housing includes leaf springs, these springs may be employed to bias the septum into a sealed condition. Specifically, the leaf springs urge the medial portion of the septum inwards, closing the slit.

[0016] When a male luer taper is pushed against the proximal surface of the
20 septum, it deflects distally and laterally and allows the male luer taper to access the slit in the septum. In addition, the distal and lateral deflection of the septum forces the slit to open and allows the male luer taper to penetrate the septum through the slit. When the male luer taper is fully inserted into the septum, the slit is forced open along the entire length of the septum so that the septum allows fluid to flow through the
25 connector. The bias of the leaf springs is overcome by the insertion of the male luer tip. The needleless luer access connector of this invention is configured so that the male luer taper does not have to extend completely through the septum to completely open the slit at the distal portion of the septum. This is achieved by ensuring that the circumference of the distal portion of the septum is held in place by the housing and by
30 increasing the mass along the distal portion of the septum. The increased mass at the distal portion of the septum is achieved by providing the distal portion of the septum with a radial dimension that is larger than the radial dimension of the medial portion of the slit. As a result of holding the circumference of the distal portion of the septum in place and the increased mass of the distal portion of the septum, the septum acts as a

swinging door to fully open the slit when the male luer taper is inserted fully into the septum. The male luer taper can thereafter be removed from the septum allowing the septum to return to its pre-stressed state and close the connector to fluid flow.

5 [0017] The external surface of the medial portion of the septum may be formed with ribs. These ribs may engage the leaf springs of the housing such that, as the male luer taper is inserted into the slit, the septum expands, forcing the ribs into the leaf springs such that the bias of the leaf springs must be overcome to insert the luer taper.

10 [0018] Alternatively, or in addition thereto, ribs may be formed in the septum that engage complementary ribs formed on the internal surface of the sidewalls of the housing. When the male luer taper is fully inserted into the septum the external surface of the medial portion of the septum engages the internal surface of the sidewalls of the housing. The ribs are located on the septum and the housing in the appropriate location so that, when the septum is accessed by the male luer taper, the ribs on the septum engage the ribs on the housing. The interengagement of the ribs causes the septum to remain temporarily locked in place with respect to the housing. Once the male luer taper has been removed sufficiently from the septum so that the external surface of the medial portion of the septum no longer engages the internal surface of the sidewalls of the housing the ribs disengage to allow the septum to return to its prestressed state. This feature prevents the septum from being pulled out of the housing when the male luer taper is removed from the connector. Various configurations for the ribs could be used to achieve this effect. For example, complementary ribs and detents or grooves or slots could be formed on the external surface of the medial portion of the housing and the internal surface of the sidewalls of the housing. Alternatively, these features could be formed along the proximal portion of the connector instead of along the medial portion of the connector.

25 [0019] A variation of the foregoing feature is the use of various key and keyhole configurations formed on the septum and the housing to prevent rotation of the septum during male luer access and removal. For example, the proximal portion of the septum could be formed with a key that fits into a keyhole formed along the proximal portion of the housing. The keys and keyholes could have various complementary shapes. The only limitation is that the keys and keyholes hold the septum against rotational movement with respect to the housing.

30 [0020] Another mechanism to facilitate the closing of the connector against fluid flow is to have the septum and housing configured so that the septum is

compressed along the sides of the slit at least at the distal portion of the septum. Alternatively or concurrently, the septum and housing can be configured so that the septum is pulled in tension at the ends of the slit. This configuration provides a tight seal to prevent leakage and microbial ingress. In order to achieve this force distribution, the distal portion of the septum could be formed with a substantially circular cross section while the housing adjacent to the distal portion of the septum when the septum is in its prestressed condition could be formed with a substantially elliptical or oval cross section. If the slit is located so that it is aligned with the major axis of the ellipse, i.e., the transverse axis of the slit and the major axis of the ellipse are collinear or parallel, the slit will be biased to a closed position. The minor axis of the ellipse will tend to compress the sides of the slit together while the major axis of the ellipse will tend to place the ends of the slit in tension thus forcing the slit closed. This effect can also be achieved by forming complementary tabs and slots in the septum and housing that pull and push the septum in the appropriate directions. In addition, this effect can be achieved by forming the distal portion of the septum with a substantially elliptical or oval cross section and the relevant portion of the housing could be formed with a substantially circular cross section. With this configuration, the transverse axis of the slit should be collinear or parallel to the minor axis of the slit. This circle will tend to pull the minor axis apart and push the major axis together to close the slit. Adhesive material may be applied to the housing and the septum, fixing the septum in a condition in which the slit is compressed closed.

[0021] The housing minimizes the amount of dead space by carefully matching the configuration of the distal portion of the septum when a male luer taper fully accesses the connector with the location and configuration of the sidewalls in the housing that form the fluid flow path through the connector. In other words, when a male luer taper is inserted into the needleless luer access connector of this invention, the distal portion of the septum is forced distally in the housing and occupies at least a portion of the space in the distal portion of the housing. The sidewalls in the connector are configured so they engage the distal portion of the septum that is displaced distally by the male luer taper. In this way, the sidewalls in conjunction with the distal portion of the septum minimizes dead space in the housing. An air passage may be provided in the housing to permit the flow of air disposed between the medial portion of the septum and the housing. Consequently, the septum may be displaced without requiring force to compress the air in the housing.

Brief Description of the Drawings

[0022] The preferred embodiments are illustrated in the drawings in which like reference numerals refer to like elements and in which:

5 [0023] Fig. 1 is an exploded perspective view of the needleless luer access connector of this invention;

[0024] Fig. 1A is a perspective view of the top portion of the housing for the needleless luer access connector of this invention showing lines in phantom to help explain the shape of the top surface of the top portion;

10 [0025] Fig. 2 is a cross-sectional view of the needleless luer access connector of this invention closed to fluid flow and with a male luer taper of another medical device such as a syringe poised for penetration of the connector;

[0026] Fig. 3 is a cross-sectional view of the needleless luer access connector of this invention with a male luer taper of another medical device such as a syringe
15 disposed in the connector so that it is open to fluid flow;

[0027] Fig. 4 is a perspective view of the needleless luer access connector of this invention;

[0028] Fig. 5 is a top plan view of the needleless luer access connector of this invention shown in Fig. 4;

20 [0029] Fig. 6 is a perspective view of a first embodiment of the septum used in the needleless luer access connector of this invention;

[0030] Fig. 7 is a perspective view in cross section of the first embodiment of the septum used in the needleless luer access connector of this invention;

[0031] Fig. 8 is a side elevational view of the first embodiment of the septum
25 used in the needleless luer access connector of this invention showing the major length of the medial portion of the septum;

[0032] Fig. 9 is an exploded perspective view in cross section of the needleless luer access connector of this invention with a second embodiment of the septum and the housing;

30 [0033] Fig. 10 is a cross sectional view of the needleless luer access connector of this invention with the second embodiment of the septum and the housing with a male luer taper of another medical device such as a syringe poised for penetration of the connector;

[0034] Fig. 11 is a cross sectional view of the needleless luer access connector of this invention with the second embodiment of the septum and the housing and a male luer taper disposed therein;

5 [0035] Fig. 12 is a cross sectional view of the needleless luer access connector of this invention with a third embodiment of the housing and a male luer taper of another medical device such as a syringe poised for penetration of the connector;

[0036] Fig. 13 is a cross sectional view of the needleless luer access connector of this invention with the third embodiment of the housing and a male luer taper of another medical device such as a syringe disposed in the connector so that it is open to
10 fluid flow;

[0037] Fig. 14 is an exploded perspective view in cross section of the needleless luer access connector of this invention with a third embodiment of the septum and a fourth embodiment of the housing;

[0038] Fig. 15 is a cross sectional view of the needleless luer access connector
15 of this invention with the third embodiment of the septum and the fourth embodiment of the housing with a male luer taper of another medical device such as a syringe poised for penetration of the connector;

[0039] Fig. 16 is a cross sectional view of the needleless luer access connector of this invention with the third embodiment of the septum and the fourth embodiment
20 of the housing with a male luer taper disposed therein;

[0040] Fig. 17 is an exploded perspective view of a portion of the needleless luer access connector of this invention showing a fourth embodiment of the septum and a fifth embodiment of the housing;

[0041] Fig. 18 is a side elevational view of the needleless luer access connector
25 of this invention showing the fourth embodiment of the septum and the fifth embodiment of the housing;

[0042] Fig. 19 is an exploded perspective view of a portion of the needleless luer access connector of this invention showing a fifth embodiment of the septum and a sixth embodiment of the housing;

30 [0043] Fig. 20 is a side elevational view of the needleless luer access connector of this invention showing the fifth embodiment of the septum and the sixth embodiment of the housing;

[0044] Fig. 21 is an exploded perspective view of a portion of the needleless luer access connector of this invention showing a sixth embodiment of the septum and the seventh embodiment of the housing;

5 [0045] Fig. 22 is a side elevational view of the needleless luer access connector of this invention showing the sixth embodiment of the septum and the seventh embodiment of the housing;

[0046] Fig. 23 is an exploded perspective view of a portion of the needleless luer access connector of this invention showing a seventh embodiment of the septum and an eighth embodiment of the housing;

10 [0047] Fig. 24 is a side elevational view of the needleless luer access connector of this invention showing the seventh embodiment of the septum and the eighth embodiment of the housing;

[0048] Fig. 25 is an exploded perspective view of a portion of the needleless luer access connector of this invention showing an eighth embodiment of the septum and a ninth embodiment of the housing;

[0049] Fig. 26 is a side elevational view of the needleless luer access connector of this invention showing the eighth embodiment of the septum and the ninth embodiment of the housing;

20 [0050] Fig. 27 is an exploded perspective view of a portion of the needleless luer access connector of this invention showing a ninth embodiment of the septum and a tenth embodiment of the housing;

[0051] Fig. 28 is a side elevational view of the needleless luer access connector of this invention showing the ninth embodiment of the septum and the tenth embodiment of the housing;

25 [0052] Fig. 29 is a top plan view in cross section of the needleless luer access connector of this invention taken along line 29-29 of Fig. 4 showing an eleventh embodiment of the housing;

[0053] Fig. 30 is a top plan view of the eleventh embodiment of housing with the septum removed from the housing;

30 [0054] Fig. 31 is a top plan view in cross section of the needleless luer access connector of this invention similar to the view of Fig. 29 but showing a twelfth embodiment of the housing;

[0055] Fig. 32 is a top plan view of the twelfth embodiment of the housing with the septum removed from the housing;

[0056] Fig. 33 is an exploded perspective view of a portion of the needleless luer access connector of this invention showing a tenth embodiment of the septum and a thirteenth embodiment of the housing;

5 [0057] Fig. 34 is an exploded cross sectional view of a portion of the needleless luer access connector of this invention showing the tenth embodiment of the septum and the thirteenth embodiment of the housing;

[0058] Fig. 35 is a top plan view of the thirteenth embodiment of the housing of the needleless luer access connector of this invention;

10 [0059] Fig. 36 is a top plan view of the tenth embodiment of the septum of the needleless luer access connector of this invention;

[0060] Fig. 37 is a bottom plan view of the distal portion of the septum having an elliptical cross section and showing in phantom that portion of the housing engaging the distal portion of the septum with a circular cross section to provide a comparison between the two;

15 [0061] Fig. 38 is a bottom plan view of the distal portion of the septum having a circular cross section and showing in phantom that portion of the housing engaging the distal portion of the septum with an elliptical cross section to provide a comparison between the two;

20 [0062] Fig. 39 is a bottom plan view of the distal portion of the septum having an elliptical cross section;

[0063] Fig. 40 is a bottom plan view of the distal portion of the septum having an elliptical cross section with a slit having a molded open configuration;

[0064] Fig. 41 is a bottom plan view of the distal portion of the septum having a circular cross section;

25 [0065] Fig. 42 is a bottom plan view of the distal portion of the septum having a circular cross section with a slit having a molded open configuration;

[0066] Fig. 43 is a bottom perspective view partially in cross section of the needleless luer access connector of this invention showing the distal portion of the septum and that portion of the housing that engages the distal portion of the septum;

30 [0067] Fig. 44 is a bottom perspective view partially in cross section of the needleless luer access connector of this invention showing the distal portion of the septum and that portion of the housing that engages the distal portion of the septum rotated 90 degrees from the view of Fig. 43;

[0068] Fig. 45 is a cross sectional view of the needleless luer access connector of this invention closed to fluid flow and a male luer taper of another medical device such as a syringe poised for penetration of the connector;

5 [0069] Fig. 46 is a cross sectional view of the needleless luer access connector of this invention with a male luer taper of another medical device such as a syringe disposed in the septum in the connector but with the connector still closed to fluid flow;

[0070] Fig. 47 is a cross sectional view of the needleless luer access connector of this invention with a male luer taper of another medical device such as a syringe disposed further in the connector but with the distal end of the male luer taper proximal
10 of the distal end of the septum but with the connector open to fluid flow; and

[0071] Fig. 48 is a cross sectional view of the needleless luer access connector of this invention with a male luer taper of another medical device such as a syringe disposed as far as it can go in the connector but with the distal end of the male luer taper proximal of the distal end of the septum and with the connector open to fluid
15 flow.

[0072] Fig. 49 is an exploded, perspective view of a housing and septum of a needleless luer access connector in which the housing is formed, in part, by leaf springs.

[0073] Fig. 50 is a side elevational view of the needleless luer access connector of Fig. 48.

20 [0074] Fig. 51 is a front elevational view of the needleless luer access connector of Fig. 48.

[0075] Fig. 52 is a cut-away front view of the needleless luer access connector of Fig. 48 showing a male luer connector disposed in a pre-insertion position.

25 [0076] Fig. 53 is a cut-away side view of the needleless luer access connector of Fig. 48 showing a male luer connector disposed in a pre-insertion position.

[0077] Fig. 54 is a cut-away side view of the needleless luer access connector of Fig. 48 showing a male luer connector inserted into the connector.

[0078] Fig. 55 is a cut-away view along lines 55-55 of Fig. 53.

[0079] Fig. 56 is a cut-away view along lines 56-56 of Fig. 54.

30 [0080] Fig. 57 is an exploded, perspective view of a housing and septum of a needleless luer access connector in which a lip is formed on the housing to engage the septum.

[0081] Fig. 58 is a cut-away front view of the needleless luer access connector of Fig. 57 showing a male luer access connector disposed in a pre-insertion position.

[0082] Fig. 59 is an exploded, perspective view of a housing and septum of a needleless luer access connector in which a lip is formed by distinct tabs mounted on the housing to engage the septum.

[0083] Fig. 60 is a cut-away front view of the needleless luer access connector of Fig. 59 showing a male luer access connector disposed in a pre-insertion position.

[0084] Fig. 61 is a cut-away side view of needleless luer access device in accord with another aspect of the invention.

[0085] Fig. 62 is a side view of a needleless luer access connector in which an adhesive is being delivered to a gap formed between the septum and the housing.

[0086] Fig. 63 is a side view of the needleless luer access connector of Fig. 63 in which the adhesive material is being cured by an ultraviolet light source.

[0087] Fig. 64 is a side view of a needleless luer access connector in which an adhesive is being delivered to a groove formed between the septum and the housing.

15 Detailed Description of the Invention

[0088] As used herein, the term “proximal,” “top” or “upwardly” refers to a location on the device that is closest to the clinician using the device and farthest from the patient in connection with whom the device is used when the device is used in its normal operation. Conversely, the term “distal,” “bottom,” “down” or “downwardly” refers to a location on the device that is farthest from the clinician using the device and closest to the patient in connection with whom the device is used when the device is used in its normal operation.

[0089] As used herein, the term “in” or “inwardly” refers to a location with respect to the device that, during normal use, is toward the inside of the device. Conversely, as used herein, the term “out” or “outwardly” refers to a location with respect to the device that, during normal use, is toward the outside of the device.

[0090] The needleless luer access connector of this invention includes a housing 10 having a top portion 12 and bottom portion 16. Typically plastic materials such as polycarbonate, or PETG could be used to form housing 10. Housing 10 defines an inlet 11 and an outlet 17 with a cavity or bore 13 extending there between. Inlet 11 is defined at the top of top portion 12 and outlet 17 is defined at the bottom of bottom portion 16 of the needleless luer access connector. Inlet 11, and thus that portion of bore 13 adjacent to inlet 11 and that portion of top portion 12 adjacent to inlet 11, must be sized and configured in conformity with at least some of the International Standards

Organization (ISO) standards for a female luer connection. This will allow a male luer slip or lock to be connected to inlet 11. Thus, inlet 11 has a maximum external diameter of about 0.265 inches (6.73 millimeters) and an internal diameter of about 0.214 inches (5.44 millimeters) to allow a male luer taper to extend into inlet 11. The exterior of the top of top portion 12 includes luer threads 14 that allow another medical device having a male luer lock to be connected to the top of proximal portion 12. Alternatively, no luer threads 14 need be formed on the exterior of the top of top portion 12 so that another medical device having a male luer slip can be connected to the top of top portion 12. Outlet 17, and thus that portion of bore 13 adjacent to outlet 17 is sized and configured as a male luer taper that complies with the ISO standards for a male luer taper. ISO standard 594-2:1998(E) requires that the male luer taper have a minimum length of about 2.953 inches (7.5 millimeters). Forming this part of housing 10 in accordance with ISO standards allows the needleless luer access connector of this invention to be connected to a standard female luer configuration of another medical device. If desired, a luer lock collar 16a may be formed about the male luer taper to lock the connector to a female luer. In such a case, the luer lock should comply with ISO standards. According to ISO standards, the root diameter R of the thread on the male luer lock fitting should be about 0.315 inches (8 millimeters) and the crest diameter C of the thread on the male luer lock fitting should be about 0.276 inches (7 millimeters). In addition, the male luer taper must extend a minimum of about 0.083 inches (2.1 millimeters) past the end of luer lock collar 16a.

[0091] As seen especially in Fig. 1, the top surface 15 of top portion 12 adjacent to inlet 11 transitions between two high points A and two low points B. Each high point A is about 180 degrees apart from each other and each low point B is also about 180 degrees apart from each other such that each high point A is about 90 degrees from each low point B. Preferably, each high point A should be greater than zero but less than about 0.050 inches (1.143 millimeters) higher than each low point B. Most preferably, each high point A should be about 0.027 inches (0.686 millimeters) higher than each low point B. To achieve a smooth circumferential top surface 15 that transitions in a smooth undulating fashion between high points A and low points B, top surface 15 can be formed by using a curved surface with a radius of about 0.30 inches (7.62 millimeters) as the template to cut the top of proximal portion 12. In geometric terms, the imaginary cylinder C1 defined by the top of proximal portion 12 can be cut with an imaginary cylinder C2 having a radius of about 0.30 inches (7.62 millimeters)

oriented 90 degrees to the longitudinal axis of the imaginary cylinder C1 defined by the top of proximal portion 12. This results in top surface 15 having the shape described. By changing the radius of the imaginary cylinder C1, the distance between high points A and low points B can be changed. See Fig. 1A. Of course, other shapes may be employed that resulted in high and low points may be employed and practice aspects of the invention.

[0092] A septum 20 is located in top portion 12 of the needleless luer access connector to control fluid flow therethrough. Typically materials such as silicone or polyisoprene could be used for form septum 20. Septum 20 has an enlarged proximal portion 21, a medial portion 22 and an enlarged distal portion 23. The top of enlarged proximal portion 21 can be formed with an annular lip 24 extending about the circumference of proximal portion 21. Lip 24 provides extra mass to give enlarged proximal portion 21 extra rigidity to prevent it from folding in when it is accessed by a male luer taper. Medial portion 22 has a cross sectional area that is smaller than the cross sectional area of proximal portion 21 and smaller than the cross sectional area of distal portion 23. Preferably medial portion 22 has a generally oblong cross-section with a major axis M1 substantially equal to the internal diameter of inlet 11. Alternatively, the major axis may be slightly greater than the internal diameter of inlet 11 to help ensure that septum 20 remains in inlet 11. The minor axis M2 of medial portion 22 is smaller than the diameter of proximal portion 21 and smaller than the internal diameter of inlet 11. Thus, medial portion 22 has a cross-sectional area that is smaller than the cross-sectional area of inlet 11. This provides a space between the external surfaces of medial portion 22 along the major axis thereof and the sidewalls of housing 10 that define inlet 11 where the material of septum 20 can be displaced when a male luer taper is disposed in septum 20. As seen in Fig. 7, enlarged distal portion 23 defines an annular slot 26 extending about the bottom thereof. In addition, an enlarged diametrical portion 27 extends across the bottom of enlarged distal portion 23.

[0093] A slit 25 is formed in septum 20 and extends longitudinally through proximal portion 21, medial portion 22 and distal portion 23. As seen in the top plan view of septum 20 of Fig. 5, slit 25 has a transverse axis T and is defined by a pair of sides 25a and a pair of ends 25b. Preferably, diametrical portion 27 of enlarged distal portion 23 extends from sides 25a of slit 25 along an apex 28 back to the bottom surface of enlarged distal portion 23. Diametrical portion 27 provides increased mass adjacent to the bottom of slit 25 to help keep slit 25 closed against fluid flow.

[0094] Septum 20 is disposed in top portion 12 of housing 10 such that enlarged proximal portion 21 rests on top of top surface 15. As a result, enlarged proximal portion 21 projects above the top of inlet 11. In addition, because of the undulating configuration of top surface 15, proximal portion 21 is pushed upon along high points A. An adhesive (such as a weld or cured adhesive material) may be employed to better secure the proximal portion 21 to the top portion 12 of the housing. Septum 20 is aligned in housing 10 such that the middle of sides 25a of slit 25 are aligned with each of the high points A and transverse axis T is aligned with low points B. Thus the minor axis of medial portion 22 is aligned with high points A and the major axis of medial portion 22 is aligned with low points B. The distal portion 23 is captured between top portion 12 and bottom portion 16 of housing 10 preferably such that the top wall of bottom portion 16 engages annular slot 26 of septum 20. The bottom wall of top portion 12 is bonded to a circumferential flange 19 formed along a medial portion of bottom portion 23 adjacent to luer lock collar 16a. If desired, an annular slot 19a can be formed in flange 19 and the bottom wall of top portion 12 can be inserted into annular slot 19a. Any standard bonding technique, such as chemical adhesive or ultrasonic welding can be used to bond top portion 12 to bottom portion 16. Preferably, medial portion 22 is held in tension when septum 20 is located in housing 10. This tension in combination with portions of proximal portion 21 being lifted up by high points A on top surface 15 results in a compressive force being exerted against sides 25a to force slit 25 closed at least at the top of proximal portion 21.

[0095] When a male luer taper of another medical device, such as a syringe, is pushed against the top of proximal portion 21 of septum 20, proximal portion 21 deflects distally and laterally and allows the male luer taper to access slit 25 in septum 20. As the male luer taper is pushed further into slit 25, medial portion 22 also deflects distally and laterally. Compare Figs. 2 and 3. By having a cross-section for medial portion 22 that is smaller than the cross-section of bore 13, space is provided inside bore 13 to allow such lateral deflection of medial portion 22. This distal and lateral deflection of septum 20 forces slit 25 to open and allows the male luer taper to penetrate septum 20 into slit 25. When the male luer taper is fully inserted into septum 20, slit 25 is forced open along the entire length of septum 20 and thus allows fluid to flow through septum 20 and the needleless luer access connector of this invention. Thereafter, the male luer taper of the other medical device can be withdrawn from slit 25. The inherent resiliency of septum 20 causes septum 20 to return to its normal

unstressed state with slit 25 closed. This prevents any further fluid flow through septum 20. An air passage 197 connects the bore 13 with the environment, permitting air to escape as the septum is deflected into the bore. As such, the air in the housing need not be compressed. Further, when male luer taper is removed, there is no vacuum
5 in the bore that would prevent the septum's return to the sealed condition.

[0096] Because septum 20 may be formed from materials such as silicone or polyisoprene, it is possible for septum 20 to stick to the male luer taper and be withdrawn from housing 10 as the male luer taper is withdrawn from housing 10. In order to avoid this potential problem, a lubricant may be provided on the top portion 12
10 of the housing. Further, an adhesive 150 such as a cured adhesive material or a weld may be used to secure the septum to the housing. Further, to better secure the septum to the housing, the top portion 12 of housing 10 and septum 20 may be formed with complementary catch features that hold proximal portion 21 of septum 20 in place. For example, a groove 50 extending at least partially about the circumference of the internal
15 surface of top portion 12 could be formed adjacent to top surface 15. In such an embodiment, two grooves 50 could be located about 180 degrees apart on the internal surface of top portion 12 aligned with high points A. Alternatively, groove 50 could extend about the entire circumference of the internal surface of top portion 12. See Figs. 9 through 11. A rib 51 could be formed along a portion of medial portion 22 and adapted to fit in groove 50. Preferably two ribs 51 are used and are located on either
20 side of medial portion 22 about 180 degrees apart along the major axis of medial portion 22. Groove 50 would be located on either side of top portion 12 to engage ribs 51. Thus, when a male luer taper enters slit 25, medial portion 22 is displaced such that ribs 51 fit into grooves 50 to hold septum 20 in housing 10 until the male luer taper has
25 been removed from septum 20. This interengagement between grooves 50 and ribs 51 avoids the potential problem of septum 20 sticking to the male luer taper and being withdrawn from housing 10 as the male luer taper is withdrawn from housing 10. Since grooves 50 and ribs 51 engage with one another when septum 20 is displaced laterally and distally by the male luer taper, the male luer taper can be removed from septum 20
30 without pulling septum 20 out of housing 10. The longitudinal location of grooves 50 and ribs 51 can be determined by simple routine experimentation to see where a portion of septum 20 engages the internal sidewall of proximal portion 12. The inherent resiliency of septum 20 allows grooves 50 and ribs 51 to disengage from each other

once the male luer taper has been removed from septum 20 and thus allows septum 10 to return to its unbiased, i.e., unstressed state.

[0097] A variation of this configuration is shown in Figs. 12 and 13 where at least one rib 61 is formed in top portion 12 adjacent to inlet 11 and extending into inlet 5 11. Preferably two ribs 61 are used and are located about 180 degrees apart so they are adjacent to high points A. Alternatively, one rib could be used that would extend about the entire circumference of the internal surface of top portion 12. Ribs 61 thus face the major axis of medial portion 22 so that when septum 20 is displaced laterally and distally when a male luer taper enters slit 25, ribs 61 engage septum 20 and hold 10 septum 20 in housing 10. Because of its inherent resiliency, septum 20 can conform to the shape of ribs 61 and thus engage with and be held by ribs 61 until the male luer taper is removed from septum 20.

[0098] The external surface of medial portion 22 of septum 20 may be formed with ribs 31 about 180 degrees apart along the major axis. In addition, complementary 15 barbs 32 may be formed on the internal sidewalls of proximal portion 12 of housing 10 adjacent to inlet 11 and aligned with high points A. See Figs. 14 through 16. Ribs 31 and barbs 32 are formed so as to engage with one another when brought into contact with each other. Thus, when the male luer taper of another medical device is fully inserted into septum 20, the external surface of medial portion 22 of septum 20 is 20 forced distally and laterally so that it engages the internal sidewalls of proximal portion 12 of housing 10. Ribs 31 are located on septum 20 and barbs 32 are located on the internal sidewalls of top portion 12 of housing 10 so that when septum 20 is fully accessed by the male luer taper, ribs 31 engage barbs 32. Preferably, two ribs 31 are formed on septum 20 about 180 degrees apart along either side of medial portion 22 25 along the major axis thereof. Preferably two barbs 32 are located on the internal sidewalls of top portion 12 about 180 degrees apart and aligned with high points A so they are adjacent to ribs 31 when a male luer taper is inserted into septum 20. The longitudinal location of ribs 31 and barbs 32 can be determined by simple routine experimentation to see where a portion of septum 20 engages the internal sidewall of 30 proximal portion 12. The interengagement of ribs 31 and barbs 32 helps to maintain septum 20 in place with respect to housing 10 as the male luer taper is being withdrawn from slit 25. This interengagement avoids the potential problem of septum 20 sticking to the male luer taper and being withdrawn from housing 10 as the male luer taper is withdrawn from housing 10. Since ribs 31 and barbs 32 interfere with and engage one

another, the male luer taper can be removed from septum 20 without pulling septum 20 out of housing 10. However, the inherent resiliency of septum 20 allows ribs 31 and barbs 32 to disengage from each other once the male luer taper has been removed from septum 20 and thus allows septum 10 to return to its unbiased state.

5 [0099] Various configurations for ribs 31 and barbs 32 could be used to achieve this effect. For example, complementary ribs and detents or grooves could be formed on the external surface of medial portion 22 of septum 20 and the internal sidewalls of top portion 12. Barbs 32 can be formed anywhere along the axial length of top portion 12 but preferably barbs 32 are located close to top surface 15 and adjacent to inlet 11.
10 This leaves a smaller portion of septum 20 above barbs 32 that may be pulled out of top portion 12 when the male luer taper is removed therefrom. If barbs 32 are located too far distally from top surface 15, a significant portion of septum 20 may be stretched and pulled out of top portion 12 if that portion of septum 20 sticks to the male luer taper.

 [00100] A variation of the foregoing feature is the use of various key and
15 keyhole configurations formed on septum 20 and top portion 12 to prevent rotation of septum 20 during insertion of a male luer taper into septum 20 or removal of a male luer taper from septum 20. See Figs. 17 through 28. This may be necessary, especially where inlet 11 is configured for a male luer lock. In such a case the male luer taper of another medical device is typically rotated with respect to housing 10 of the needleless
20 luer access connector of this invention to insert the male luer taper into the connector and lock it in place and to unlock the male luer taper and remove it from the connector. For example, a key 40 could be formed on septum 20 adjacent to enlarged proximal portion 21 of septum 20 along the minor axis of medial portion 22 and aligned with, i.e., collinear or parallel, transverse axis T of slit 25 and the major axis of medial
25 portion 22. Key 40 could merely be an extension from one side of septum 20 and can be formed in any shape. For example, a simple rectangular shape, see Figs. 17 and 18, could be used as well as a triangular, see Figs. 19 through 22, or other polygonal shape, see Figs. 23 and 24, could be used. Preferably, two keys 40 are used and are located about 180 degrees apart and aligned with transverse axis T and the major axis of medial
30 portion 22. A complementary slot or keyhole 41 could be formed along adjacent to top surface 15 at top portion 12 of housing 10. Preferably, two keyholes 41 are used and are located about 180 degrees apart aligned with the low points B. Keys 40 need not extend to the periphery of enlarged proximal portion 21 and keyholes 41 need not extend completely through the sidewall of top portion 12. Instead, keys 40 could be

formed as a rib extending from medial portion 22 and keyholes 41 could be formed as complementary grooves formed in the internal sidewall of top portion 12. The only limitation is that keys 40 and keyholes 41 must be configured and located with respect to each other so that they combine to hold septum 20 against rotational movement with respect to housing 10. Moreover, keys 40a could be formed along top surface 15 of top portion 12 of housing 10 and keyholes 41a can be formed in septum 20 adjacent to proximal portion 21. See Figs. 25 through 28. Preferably two keys 40a and two keyholes 41a are used with keys 40a about 180 degrees apart and keyholes 41a about 180 degrees apart. Keys 40a or keyholes 41a can be located anywhere about the circumference of proximal portion 21. However, preferably keys 40a are aligned with low points B and keyholes 41a are aligned with the major axis of medial portion 22 and transverse axis T of slit 25. Although the embodiments of Figs. 17 through 28 preferably have a top surface 15 with high points A and low points B, the keys and keyholes of these embodiments could be used where the needleless luer access connector of this invention has a flat top surface 15 with no high or low points.

[00101] Bore 13 could be formed with a longitudinally extending groove 71 that engages the ends of medial portion 22. See Figs. 29 and 30. Preferably, two grooves 71 are used and each groove 71 is preferably about 180 degrees apart and substantially aligned with the low points B. In this manner each end of medial portion 22 parallel to the minor axis engages grooves 71 to hold septum 20 against rotation with respect to bore 13. Alternatively, bore 13 could be formed with two shoulders 72 therein that engage the ends of medial portion 22. See Figs. 31 and 32. Again, preferably two shoulders 72 are used and each shoulder 72 is preferably about 180 degrees apart and substantially aligned with the low points B. These configurations for bore 13 help to hold medial portion 22, and thus septum 20, in place against rotation with respect to housing 10 where a male luer taper is inserted or removed from septum 20 by twisting the male luer taper.

[00102] Since proximal portion 21 of septum 20 merely rests on top surface 15 of top portion 12 of housing 10, it is possible that proximal portion 21 could be forced into bore 13 of top portion 12 when a male luer taper is pressed against the top of proximal portion 21. A configuration for septum 20 and housing 10 that helps to hold proximal portion 21 in place when a male luer taper is forced into slit 25 is shown in Figs. 33 through 36. In this embodiment, risers 81 are formed in top portion 12 adjacent to and extend up from top surface 15 and are about 180 degrees apart. Risers

81 include outwardly extending flanges 82 thereon. Slotted portions 83 are formed along the periphery of proximal portion 21 and allow flanges 82 to extend into and through slotted portions 83. Preferably two slotted portions 83 about 180 degrees apart are formed on proximal portion 21 and extend generally parallel to transverse axis T of slit 25 on either side thereof. If desired, a barb can be formed on risers 81 or flange 82 to engage slotted portions 83 and help hold slotted portions 83 in place with respect to top surface 15. This engagement also helps to hold proximal portion 21 in place when a male luer taper is forced into slit 25. Preferably, top surface 15 is flat in this embodiment. However, if desired, top surface 15 may be formed with an undulating curved surface with two high points and two low points as in the other embodiments. If such an undulating surface were used, risers 81 would include the high points.

[00103] In order to facilitate the closing of slit 25 against fluid flow, the portion of housing 10 that engages distal portion 23 of septum 20 can be configured so that housing 10 compresses distal portion 23 of septum 20 along the sides of slit 25. Alternatively or concurrently, the portion of housing 10 that engages distal portion 23 of septum 20 can be configured so housing 10 pulls distal portion 23 of septum 20 in tension at the ends of slit 25, i.e., along transverse axis T. One way to achieve this force distribution is for distal portion 23 of septum 20 to be formed with a substantially circular cross section while the portion 12 of housing 10 that engages distal portion 23 is formed with a substantially elliptical or oval cross section. See Fig. 38. By locating slit 25 so that transverse axis T is parallel to the major axis of the ellipse, slit 25 will be biased to a closed position. This is because the minor axis of the ellipse will tend to compress sides 25a of slit 25 together while the major axis of the ellipse will tend to pull ends 25b of slit 25 in tension thus forcing slit 25 closed. As noted above, either tension along slit 25 or compression perpendicular to slit 25 can be applied and not necessarily both. Only tension can be achieved by forming the minor axis of the ellipse so that it is substantially equal to the diameter of the circular cross section of distal portion 23 and forming the major axis of the ellipse so that it is greater than the diameter. Only compression can be achieved by forming the minor axis of the ellipse so that it is smaller than the diameter and forming the major axis of the ellipse so that it is substantially equal to the diameter. This effect can also be achieved by forming complementary tabs and slots in distal portion 23 of septum 20 and the portion of housing 10 that engages distal portion 23 to pull and push distal portion 23 in the appropriate directions as described above.

[00104] Alternatively and preferably, distal portion 23 of septum 20 is formed in an elliptical configuration and the portion of housing 10 that engages distal portion 23 is formed with a circular cross section. See Fig. 37. When distal portion 23 has an elliptical configuration transverse axis T of slit 25 is preferably aligned with, i.e., collinear, with the minor axis of the ellipse. This configuration for distal portion 23 and that portion of housing 10 that engages distal portion 23 facilitates manufacturing of the needleless access connector of this invention because it does not require special alignment between distal portion 23 and housing 10. Only tension can be achieved by forming the minor axis of the ellipse so that it is less than the diameter of the circular cross section of distal portion 23 and forming the major axis of the ellipse so that it is substantially equal to the diameter. Only compression can be achieved by forming the minor axis of the ellipse so that it is substantially equal to the diameter and forming the major axis of the ellipse so that it is greater than the diameter. Preferably, with this configuration, the minor axis of distal portion 23 is about 0.360 inches (9.144 millimeters) and the major axis of distal portion 23 is about 0.430 inches (10.922 millimeters) when distal portion 23 is in its unstressed state. If desired, slit 25 can be formed so it is open when distal portion 23 is in its unstressed state. In this situation, slit 25 has an elliptical cross section at distal portion 23 with a minor axis of about .030 inches (0.762 millimeters) and a major axis of about 0.175 inches (4.445 millimeters) and distal portion 23 has a minor axis of about 0.360 inches (9.144 millimeters) and a major axis of about 0.460 inches (11.684 millimeters). See Fig. 40. Of course, septum 20 can be formed with a circular cross section at distal portion 23 and an open slit 25. See Fig. 42. Alternatively, septum 20 can be formed with an elliptical cross section at distal portion 23 with a closed slit 25, see Fig. 39, or a circular cross section at distal portion 23 and a closed slit 25, see Fig. 41.

[00105] When a male luer taper is pushed against the top proximal surface of septum 20, proximal portion 21 deflects distally and laterally and allows the male luer taper to access slit 25 in septum 20. As the male luer taper is pushed further into slit 25, medial portion 22 also deflects distally and laterally. By having a cross-section for medial portion 22 that is smaller than the cross-section of bore 13, space is provided in housing 10 to allow such lateral deflection of medial portion 22. This distal and lateral deflection of septum 20 forces slit 25 to open and allows the male luer taper to penetrate septum 20 through slit 25. When the male luer taper is fully inserted into septum 20, slit 25 is forced open along the entire length of septum 20

[00106] Because of certain ISO standards, it is important that slit 25 is open along the entire length of septum 20 even if the male luer taper does not extend completely through septum 20. For male luer locks, ISO standard 594-2:1998(E) requires that the male luer taper have a minimum length of about 0.295 inches (7.5 millimeters) and extend a minimum of 0.083 inches (2.1 millimeters) past the end of the luer lock collar. Many manufacturers make their products with this minimum dimension. In the needleless access connector of this invention, the distance X between the top of the medial sidewall of proximal portion 12 and the bottom of septum 20 is about 0.110 inches (2.794 millimeters). Thus it can be seen that where a male luer taper having the minimum ISO dimensions is used to access the needleless access connector of this invention, the male luer taper will not extend completely through septum 20. Because of these dimensions, septum 20 must be designed so that slit 25 is forced open even if the male luer taper does not extend completely through septum 20. When a male luer taper is inserted into septum 20 a distance of about 0.214 inches (5.436 millimeters) from the top of septum 20, the bottom of slit 25 begins to open. When the male luer taper is inserted as far as it can extend into the needleless access connector, distal portion 23 can only be deflected distally down into bore 13 below where the bottom of distal portion 23 extends when it is not accessed by a male luer taper. This distal deflection causes distal portion 23 to act as a swinging door and fully open slit 25. There is only distal deflection of distal portion 23 because the circumference of distal portion 23 is held in place between proximal portion 12 and distal portion 16 of housing 10 and there is no room for distal portion 23 to move except distally. In addition, distal portion 23 has an increased mass by virtue of its thickness, which is about 0.050 inches (1.27 millimeters) and which tapers up to about 0.080 inches (2.032 millimeters) immediately adjacent to slit 25. This combination of holding distal portion 23 against lateral movement and the increased mass of distal portion forces slit 25 open and allows fluid to flow through the needleless luer access connector even if the male luer taper does not completely penetrate septum 20.

[00107] Housing 10 is designed to minimize the amount of any dead space therein where fluid could flow and be trapped. Any such trapped fluid can provide a breeding ground for microbes and other organisms that could travel through the needleless luer access connector and into the patient to infect the patient. Preferably, walls 60 are formed in distal portion 16 of housing 10 to fill any dead space therein. Walls 60 have an upwardly facing surface 61 that matches the configuration of

distal portion 23 of septum 20 when a male luer taper fully accesses the needleless luer access connector of this invention. See Fig. 48. In this way, walls 60 do not interfere with the normal operation of the invention while still filling any unused space within housing 10.

5 [00108] Thus, it is seen that a needleless access connector is provided that can be accessed without the use of a needle, that is not prone to leakage or microbial ingress, that minimizes the dead space volume therein, that does not require a high degree of force to access and minimizes the kickback force when the connector is accessed and that does not require any additional or special devices to access.

10 [00109] The needleless luer connector discussed above may be modified to achieve distinct performance characteristics depending on the intended application of the connector. Specifically, in certain implementations of aspects of the invention, it may be desirable to design the housing to exert a compressive force on the septum, urging the slit to a closed condition. A mechanical bond may be formed between the
15 housing and the septum. This bond maintains the septum in position under the force exerted by the male luer taper during insertion and maintains the slit in a closed condition when the male luer taper is not in the slit. It will be appreciated that these modifications may be employed on other connectors and still practice aspects of the invention.

20 [00110] Referring now to Figs. 49-64, the needleless luer access connector 100 may include a substantially cylindrical base 110 having an axis 112 extending from a proximal direction to a distal direction. Elastic members, such as leaf springs 111, are attached to the base and extend in the proximal direction, thereby defining a channel 113. The septum or valve 130 has a proximal portion 131, a medial
25 portion 132 and a distal portion 133. The proximal portion and the distal portion preferably have circular cross sections when not stressed (such as depicted in Fig. 49). The medial portion preferably has an oval cross section when not stressed (such as depicted in Figs. 49 and 55). The oval cross section of the medial portion has a major axis M1 and a minor axis M2 (see Fig. 55). A longitudinal slit 136 extends through the
30 septum from the proximal portion through the medial portion and into the distal portion such that, when a male luer taper is inserted into the slit, the medial portion is expanded. See Figs. 54 and 56.

 [00111] When assembled for use, the distal portion 133 of the septum 130 is disposed within the base 110 of the housing 115. The medial portion 132 of the

septum is disposed within the channel 113. A lubricant may be disposed along the medial portion of the septum. The proximal portion of the septum 131 is seated on the leaf springs 111 remote from the base. Specifically, the proximal portion is disposed on the top edge 120 of the leaf springs. The leaf springs are sized such that the septum is in tension in an axial direction. This tension in combination with the positioning of the housing remote from the slit 136 urges the slit to a closed condition. Further, in one particular embodiment, at least one leaf spring is operably engaged to the medial portion of the septum along its major axis M1 and at least one leaf spring is operably engaged to the medial portion of the septum along its minor axis M2. Preferably, two leaf springs are mounted to the base and include threads to engage a luer connector. These leaf springs are engaged to the medial portion of the septum along its major axis (see Fig. 52). Two other leaf springs are mounted to the base and angle inward toward the axis of the base. These leaf springs contact the medial portion of the septum near the proximal portion of the septum along its minor axis (see Fig. 53). Ribs 137 may be positioned on the exterior surface 138 of the medial portion and the bottom surface 139 of the proximal portion such that the leaf springs contact the ribs. Preferably, the ribs are integrally formed with the septum. When the male luer connector is inserted into the connector, the medial portion and the ribs are displaced outwardly, overcoming the bias of the leaf springs along the minor axis M2 (see Fig. 54).

[00112] Referring to Figs. 52-54, before the male luer tip is inserted into the slit 136, the leaf springs 111 exert a force on the medial portion 132 of the septum 130, via the ribs 137, urging the slit to a closed condition. As the male luer taper is inserted into the slit, the septum expands to receive the taper. The medial portion of the septum expands against the leaf springs, flexing them outwards. The adhesive bond between the septum and the housing helps prevent the septum from being forced into the housing during insertion of the male luer taper.

[00113] In certain implementations of this aspect of the invention, a lip 114 is attached at a proximal end of at least one of the leaf springs 111 such that the lip encloses at least a part of the proximal portion 131 of the septum 130. An adhesive material 150 may be disposed between the septum and the leaf springs, securing the septum to the leaf springs.

[00114] Referring to Figs. 57-60, the needleless access connector 100 includes a housing 115 having a base portion 110 with a proximal surface 124 and a sidewall 125 positioned on the base portion. The sidewall may be integrally formed

with the base portion. Further, the side wall may be formed of leaf springs or other elastic members 111. The sidewall includes a top portion 120 having a periphery and defining an inlet opening 121. The top portion of the housing includes two diametrically opposed high points A and two diametrically opposed low points B, and the diametrically opposed low points are disposed along the transverse axis T of the slit 136 (see also Figs. 1, 1A, 4 and 5). The sidewall defines a channel 113 which is in fluid flow communication with the inlet opening 121. The septum 130 is disposed in the housing. The medial portion 132 of the septum has a cross section less than the cross section of the proximal portion. Further, the cross section of the medial portion is less than the cross section of the channel. The longitudinal slit 136 has a transverse axis T (see Fig. 5) and extends through the septum from the proximal portion 131 through the medial portion 132 and into the distal portion 133 such that, when a male luer taper 200 is inserted into the slit, the distal portion is moved both laterally and distally to open a flow path through the channel. The lip 114 is attached at the periphery of the top portion 120 of the housing 115 such that the lip encloses at least a part of the proximal portion 131 of the septum 130. An air hole 197 may be included in the housing to prevent a sealed air condition between the medial portion of the septum and the housing. Such a sealed air condition may prevent full insertion of the male luer tip or, upon removal of the tip, may prevent the septum from returning to the sealed condition.

[00115] Preferably, the lip 114 is integrally formed with the housing 115 and extends contiguously around the periphery of the top portion 120 of the housing, thereby completely surrounding the proximal portion 131 of the septum 130. Of course, the lip may be formed of distinct tabs 116 that engage the proximal portion of the septum at selected locations (see Fig. 59). Preferably, the lip is sized such that it exerts a compressive force on the proximal portion of the septum, urging it toward the sealed condition. Specifically, it is preferred that the lip exerts a compressive force in a direction perpendicular to the transverse axis T of the slit 136.

[00116] The proximal portion 131 of the septum 130 has a peripheral rim 141 with a thickness T2. The height H of the lip may be selected such that it is less than the thickness of the peripheral rim and the top surface 142 of the proximal end of the septum project above the lip. Alternatively, the height of the lip may be selected such that it is greater than the thickness of the rim such that the surface of the septum is recessed within the lip. The lip may also be sized such that it is the same height as the

rim. An adhesive material 150 may be disposed between the proximal portion of the septum and the top portion 120 of the sidewall to better secure the septum in place during use.

[00117] In accord with an aspect of the invention, the lip 114 may be employed to mechanically secure the rim of the septum to the housing. Specifically, 5 the lip may be rolled over the rim, such as by cold forming or with heat or ultrasonically. In such case, the lip (before rolling) is preferably taller than the rim. It is rolled over to pinch the rim between the lip and the housing.

[00118] In accord with another aspect of the invention, a method is provided for permitting selective infusion of fluids into a patient by means of a blunt 10 cannula. The housing 115 has a base 110 with a top surface 120 defining an inlet opening 121. At least one sidewall 125 extends from a base portion 110 and defines a channel 113. The base portion has an outlet opening 126 such that the inlet opening and the outlet opening are in fluid flow communication. The septum 130 is inserted 15 into the housing. The proximal portion 131 of the septum has a distal surface 139 disposed at the top surface 120 of the housing. The medial portion 132 of the septum is disposed, at least in part, in the channel of the housing. The septum defines a slit 136 passing at least through its proximal portion. An adhesive 150 is applied to the housing and the septum while the septum is deformed into a compressed state, urging the slit to 20 a closed position. This compressed state may be achieved by employing actuators to compress the septum, or by shaping the housing to effect a compressive force on the proximal portion of the septum. As currently preferred, in accord with one aspect of the invention the compressive force is achieved by the saddle shape of the top surface of the housing discussed in connection with Fig. 1A above. Once the septum is in the 25 compressed state, the adhesive is cured such that the septum is maintained in the compressed state by the cooperation of the cured adhesive and the housing.

[00119] The adhesive material 150 may be applied in various fashions to maintain the septum in place. In accord with one aspect of the invention, the adhesive 150 is applied at a groove 122 formed by the proximal portion 131 of the septum 130 30 and the top portion 120 of the housing 115. To deliver the adhesive material at a location between the top edge 120 of the housing 115 or leaf springs 111, actuators, such as mechanical fingers, may be employed to curl up the edge of the rim 141 of the septum 130. Consequently, a gap 123 is formed between the septum and the housing into which liquid adhesive material may be applied, such as by spraying. Additionally,

actuators may be employed after the adhesive is applied to maintain the septum in a compressed state while the adhesive cures. In certain applications, the adhesive may be curable by application of ultraviolet light. In such a case, at least the top portion 12 of the housing is formed of a translucent material. UV light is provided by a UV light source 160 and delivered through the top portion of the housing to the adhesive, thereby curing the adhesive material.

[00120] It will be appreciated that certain aspects of the invention may be employed with other septum/housing arrangements. For example, as seen in Fig. 61, the septum 330 may be formed of an elastomeric tube 332 with openings 340 disposed at the distal end 333 of the septum. A plug 341 seals the distal end of the tube before the male luer taper is inserted therein. An adhesive material 350 secures the proximal end 331 of the septum in place on the housing. A slit 336 extends through the proximal end of the septum and is maintained in a sealed condition until the male luer taper is inserted therein. As discussed in U.S. Patent 5,242,393, incorporated herein by reference, when the male luer tip is inserted into the slit, the elastomeric tube is displaced to create a fluid flow path through the tube, through the opening and through the housing. The adhesive material helps maintain the proximal portion of the septum in place on the housing during insertion of the male luer tip.

20

We Claim:

1. A needleless luer access connector including:
 - a substantially cylindrical base having an axis extending from a proximal direction to a distal direction;
 - 5 leaf springs attached to the base and extending in the proximal direction, thereby defining a channel, wherein the channel has a cross section;
 - a septum having a proximal portion, a medial portion and a distal portion, wherein the proximal portion and the distal portion have circular cross sections when not stressed and wherein the medial portion has an oval cross section when not stressed,
 - 10 the oval cross section having a major axis and a minor axis;
 - wherein the distal portion of the septum is disposed within the base, the medial portion of the septum is disposed within the channel and the proximal portion is seated on the leaf springs remote from the base;
 - wherein at least one first leaf spring is operably engaged to the medial portion of
 - 15 the septum along the major axis of the medial portion;
 - wherein at least one second leaf spring is operably engaged to the medial portion of the septum along the minor axis of the medial portion; and
 - a longitudinal slit extending through the septum from the proximal portion through the medial portion and into the distal portion such that, when a male luer taper
 - 20 is inserted into the slit, the medial portion is expanded.
 2. The needleless luer access connector of claim 1 further including a lip attached at a proximal end of at least one of the leaf springs such that the lip encloses at least a portion of the proximal portion of the septum.
 - 25 3. The needleless luer access connector of claim 1 further comprising an adhesive material disposed between the septum and the leaf springs, securing the septum to the leaf springs.
 - 30 4. The needleless luer access connector of claim 1 further comprising two leaf springs operably engaged to the medial portion of the septum along the minor axis of the oval cross section wherein, when a male luer taper is inserted into the slit, the medial portion is expanded, thereby deflecting the leaf springs outwardly.

5. The needleless luer access connector of claim 1 wherein the second leaf spring extends in the proximal direction from the base, angled toward the axis and contacting the septum only at a proximal end of the second leaf spring.

5 6. The needleless luer access connector of claim 1 wherein the medial portion of the septum includes a rib extending substantially in a radial direction along the minor axis and contacting at least one leaf spring.

7. The needleless luer access connector of claim 1 further including:
10 a lip attached at a proximal end of the leaf springs such that the lip encloses at least a portion of the proximal portion of the septum;
an adhesive material disposed between the septum and the leaf springs, securing the septum to the leaf springs;
two first leaf springs operably engaged to opposite sides of the medial portion of
15 the septum along the major axis of the cross section;
two second leaf springs extending in the proximal direction angled toward the axis and operably engaged to opposite sides of the medial portion of the septum along the minor axis of the oval cross section wherein, when a male luer taper is inserted into the slit, the medial portion is expanded, deflecting the leaf springs outwardly.

20 8. A connector for use with a male taper including:
a housing with a base;
leaf springs attached to the base and defining a channel, wherein the channel has a cross section;
25 a septum having a proximal portion and a medial portion, wherein the medial portion of the septum is disposed within the channel and the proximal portion is seated on the leaf springs remote from the base; and
a longitudinal slit extending through the septum from the proximal portion through to the medial portion such that, when a male taper is inserted into the slit, the
30 slit is moved from a closed condition, in which the septum prevents fluid flow through the housing, to an open position, in which fluid may flow through the septum;
wherein the leaf springs are operably engaged to the septum, biasing the septum to the closed condition.

9. The connector of claim 8 in which at least one rib is mounted to the medial portion of the septum, which rib engages at least one of the leaf springs.

10. The connector of claim 9 wherein the medial portion of the septum has
5 an exterior surface and wherein the rib is connected to the exterior of the medial portion and to a bottom surface of a proximal portion of the septum.

11. The connector of claim 9 wherein the rib is integrally formed with the
10 septum.

12. The connector of claim 9 further comprising an adhesive material
disposed between the leaf springs and the septum, securing the septum to the leaf
springs.

13. The connector of claim 12 further comprising a lip disposed at a
15 proximal portion of the leaf springs enclosing at least a portion of the proximal portion of the septum and biasing the proximal portion of the septum toward a closed condition.

14. A needleless access connector including:
20 a housing having a base portion with a proximal surface and a sidewall positioned on the base portion, wherein the sidewall includes a top portion having a periphery and defining an inlet opening and the sidewall defines a channel having a cross section, wherein the inlet opening and the channel are in fluid flow
25 communication;

a septum disposed in the housing, the septum having a proximal portion, a medial portion and a distal portion, the medial portion having an external surface and a cross section less than the cross section of the proximal portion and less than the cross section of the channel;

30 a longitudinal slit having a transverse axis extending through the septum from the proximal portion through the medial portion and into the distal portion such that, when a male luer taper is inserted into the slit, the distal portion is moved both laterally and distally to open a flow path through the channel; and

a lip attached at the periphery of the top portion of the housing such that the lip encloses at least a portion of the proximal portion of the septum.

15 15. The needleless access connector of claim 14 wherein the lip extends contiguously around the periphery of the top portion.

10 16. The needleless access connector of claim 14 wherein the proximal portion of the septum has a peripheral rim with a thickness and the lip has a height, wherein the height of the lip is less than the thickness of the peripheral rim.

15 17. The needleless access connector of claim 14 wherein the proximal portion of the septum has a peripheral rim with a thickness and the lip has a height, wherein the height of the lip is equal to or greater than the thickness of the peripheral rim.

15 18. The needleless access connector of claim 14 wherein the lip is integrally formed with the top portion of the housing.

20 19. The needleless access connector of claim 14 wherein the lip comprises a plurality of discrete tabs.

25 20. The needleless access connector of claim 14 further comprising an adhesive disposed between the proximal portion of the septum and the top portion of the sidewall and wherein the lip exerts a compressive force on the proximal portion of the septum.

30 21. The needleless access connector of claim 14 wherein the lip exerts a compressive force in a direction perpendicular to the transverse axis of the slit.

30 22. The needleless access connector of claim 14 wherein the top portion of the housing includes two diametrically opposed high points and two diametrically opposed low points.

23. The needleless access connector of claim 14 wherein the diametrically opposed low points are disposed along the transverse axis of the slit.

24. The needleless access connector of claim 14 wherein the sidewall of the housing is formed by a plurality of leaf springs mounted to the base portion.

5 25. A needleless luer access connector including:

a housing having a base portion defining a base opening, elastic members positioned on the base portion about the base opening and defining a channel, and a top edge disposed on the elastic members distal to the base portion, wherein the top edge defines an inlet opening and the channel has a cross section;

10 a valve disposed in the housing, the valve having a proximal portion, a medial portion and a distal portion, the medial portion having an external surface and being disposed, at least in part, within the channel; and

a longitudinal slit extending through the valve along a transverse axis from the proximal portion through the medial portion and into the distal portion such that, when
15 a male luer taper is inserted into the slit, the valve is deformed such that the distal portion is moved both laterally and distally and the medial portion is expanded to contact and displace the elastic members such that the elastic members exert a reactive force urging the slit to a closed position.

20 26. The luer access connector of claim 25 further including a lip attached at the periphery of the top edge of the housing such that the lip encloses at least a portion of the proximal portion of the valve.

25 27. The luer access connector of claim 25 wherein the medial portion of the valve has an oval cross section with a major axis and a minor axis, and wherein the elastic members include two side members which are disposed on opposite sides of the medial portion along the minor axis and wherein the two side members are in contact with the valve when the valve is undeformed.

30 28. The luer access connector of claim 27 wherein the elastic members include two end members disposed on opposite side of the medial portion along the major axis and wherein the two end members are in contact with the valve when the valve is undeformed.

29. The luer access connector of claim 27 wherein the medial portion of the valve further comprises at least one rib disposed, at least in part, along the minor axis and engaging at least one side member.

5 30. The luer access connector of claim 29 wherein the rib extends from the proximal portion of the valve along the medial portion.

31. The luer access connector of claim 27 wherein the medial portion of the valve further comprises two ribs disposed on opposite side of the medial portion and, at least in part, along the minor axis, each rib engaging a side member.

10

32. A method of forming an infusion site for permitting selective infusion of fluids into a patient by means of a blunt cannula, the method including:

15 providing a housing that has a top portion with a top surface defining an inlet opening, at least one sidewall extending from the top portion and defining a channel, and a base portion having an outlet opening such that the inlet opening and the outlet opening are in fluid flow communication;

20 inserting a septum in the housing, the septum having a proximal portion, a medial portion and a distal portion, the proximal portion having a distal surface disposed at the top surface of the housing and the medial portion disposed, at least in part, in the channel of the housing;

wherein the septum defines a slit passing at least through the proximal portion; applying an adhesive to the housing and the septum;

25 deforming the septum into a compressed state, thereby urging the slit to a closed position; and

curing the adhesive such that the septum is maintained in the compressed state by the cooperation of the cured adhesive and the housing.

33. The method of forming an infusion site of claim 32 wherein the adhesive is applied at a groove formed by the proximal portion of the septum and the top portion of the housing.

30

34. The method of forming an infusion site of claim 32 further comprising displacing the proximal portion of the septum from the top surface of the housing to create a gap, wherein the adhesive is injected into the gap.

5 35. The method of forming an infusion site of claim 32 wherein the adhesive is a UV curable adhesive and at least the top portion of the housing is formed of a translucent material, the method further comprising:
providing a UV light source;
selectively delivering UV light from the light source, through the top portion of
10 the housing to the adhesive; and
curing the adhesive by application of the UV light.

36. The needleless luer access connector of claim 32 wherein the adhesive is
a weld.

15

37. A method of forming a needleless access connector, including:
providing a housing that has a top portion with a top surface defining an inlet
opening, at least one sidewall extending from the top portion and defining a channel
having a cross section, and a bottom portion having an upper surface defining an upper
20 cavity and an outlet opening extending from the upper cavity such that the inlet opening
and the outlet opening are in fluid flow communication;

providing a septum having a proximal portion, a medial portion and a distal
portion, the proximal portion having a distal surface and the medial portion having an
external surface with a cross section that is less than the cross section of the channel
25 wherein the septum includes a longitudinal slit extending along a transverse axis
through the septum from the proximal portion through the medial portion and into the
distal portion;

wherein, when a male luer taper is inserted into the slit, the distal portion is
moved both laterally and distally into contact with the upper surface of the upper
30 cavity;

inserting the septum into the housing such that the proximal portion of the
septum is seated on the top surface of the housing, the medial portion of the septum is
seated in the channel and the distal portion is disposed in the bottom portion;

applying a compressive force to the septum in a direction that is perpendicular, at least in part, to the transverse axis; and

securing the housing and the septum in a fixed spatial relationship while applying the compressive force.

5

38. The method of forming a needleless access connector of claim 37 wherein the top portion of the housing includes two diametrically opposed high points and two diametrically opposed low points and wherein the diametrically opposed low points are disposed along the transverse axis of the slit.

10

39. The method of forming a needleless access connector of claim 37 further comprising applying an actuator to the proximal portion of the septum and the top surface of the housing to create a gap, applying an adhesive into the gap, and curing the adhesive in the gap.

15

40. The method of forming a needleless access connector of claim 39 wherein the adhesive is selected from the group containing UV curable adhesives, thermoset adhesives, cyanoacrylate adhesives, moisture cure adhesives, pressure cure adhesives, epoxy or RTV adhesives.

20

41. The method of forming a needleless access connector of claim 40 wherein the adhesive is a UV curable adhesive and either the top portion of the housing or the proximal portion of the septum is formed of a translucent material, the method further comprising providing a UV light source, delivering UV light from the light source, through the top portion of the housing to the adhesive, curing the adhesive by application of the UV light.

25

42. The method of claim 37 wherein securing the top surface of the housing and the distal surface of the proximal portion of the septum in a fixed relationship comprises welding the housing to the septum.

30

43. The method of claim 42 wherein the weld is formed by one of the group of ultrasonic welding, laser welding or heat staking.

44. A needleless luer access connector including:
a housing comprising a top portion with a top surface defining an inlet opening,
at least one sidewall extending from the top portion and defining a channel, and a
bottom portion having an outlet opening such that the inlet opening and the outlet
5 opening are in fluid communication;
a septum seated on the top surface of the housing, and having a resealable slit
therein, the slit being movable from a closed position in which a fluid-tight seal is
formed to an open position in which a fluid flow path is established through the
septum;
10 an adhesive operably engaged to the housing and the septum, securing the
septum to the top surface of the housing in a compressed state wherein the resealable
slit is urged toward the closed position.

45. The needleless luer access connector of claim 44 further comprising a
15 valve operably engaged to the housing for selectively permitting fluid flow through the
channel.

46. The needleless luer access connector of claim 45 further comprising an
elastic member connecting the valve to the septum.

- 20 47. The needleless luer access connector of claim 46 wherein the elastic
member is disposed within the channel, free to slide with respect to the housing.

48. The needleless luer access connector of claim 44 wherein the resealable
25 slit is disposed in a transverse plane and the adhesive is substantially disposed on an
adhesive plane, wherein the adhesive plane and the transverse plane are substantially
perpendicular and wherein the septum is compressed in a direction that is
perpendicular, at least in part, with the transverse plane.

1/48

FIG. 1

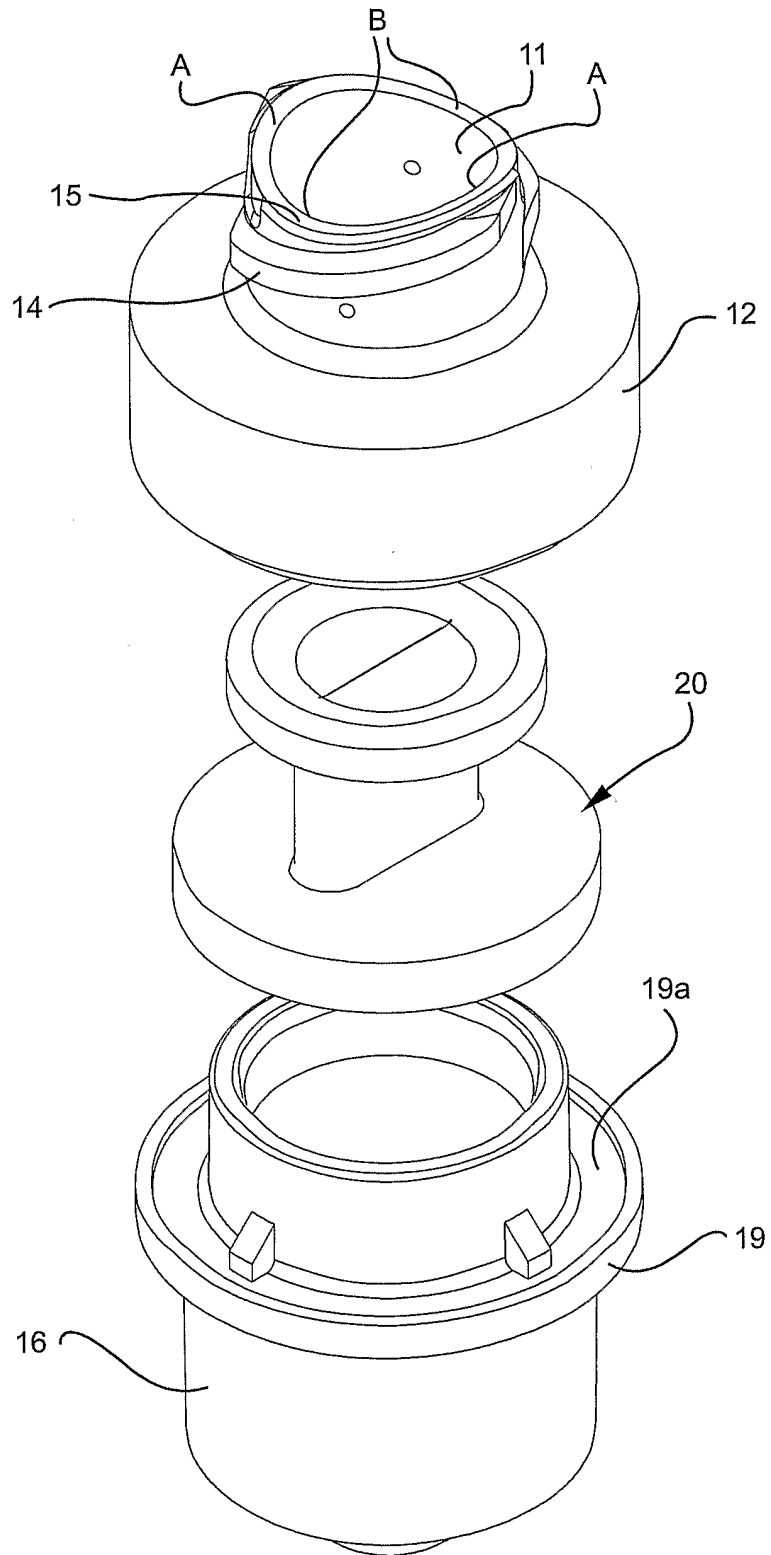
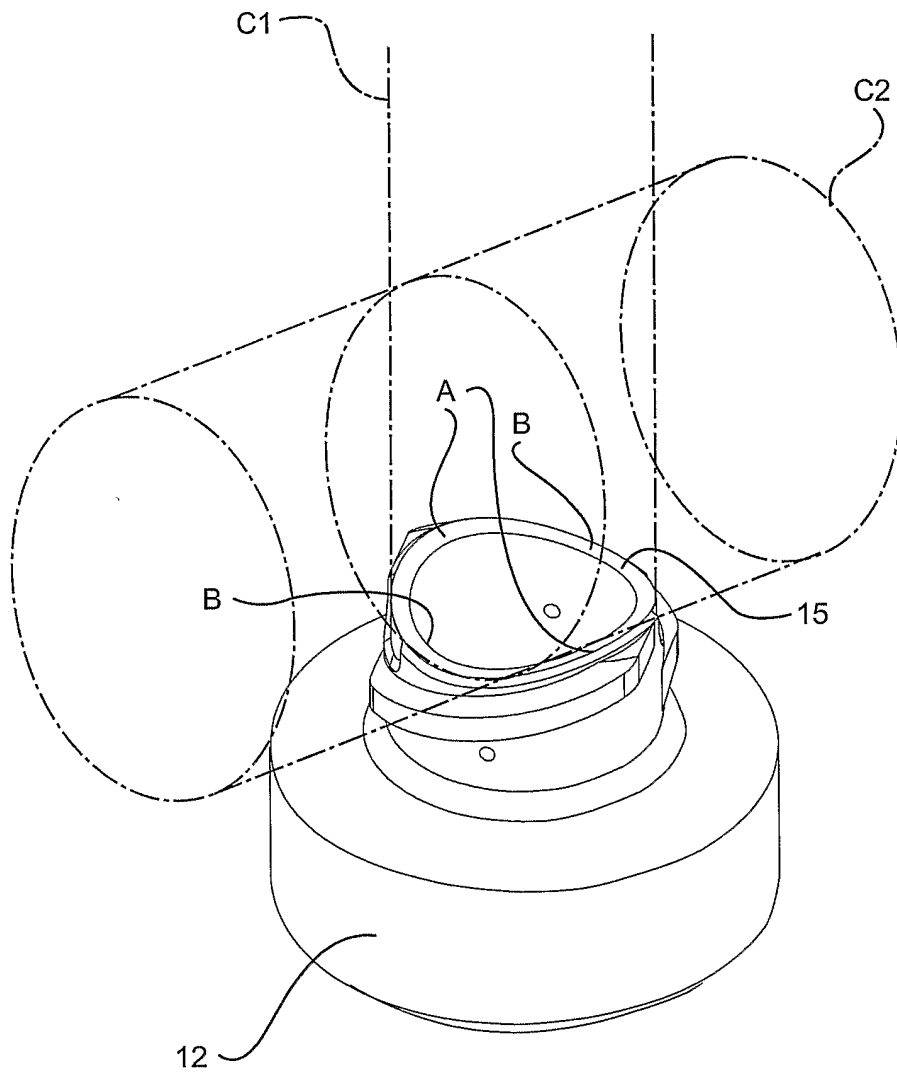

FIG. 1A



3/48

FIG. 2

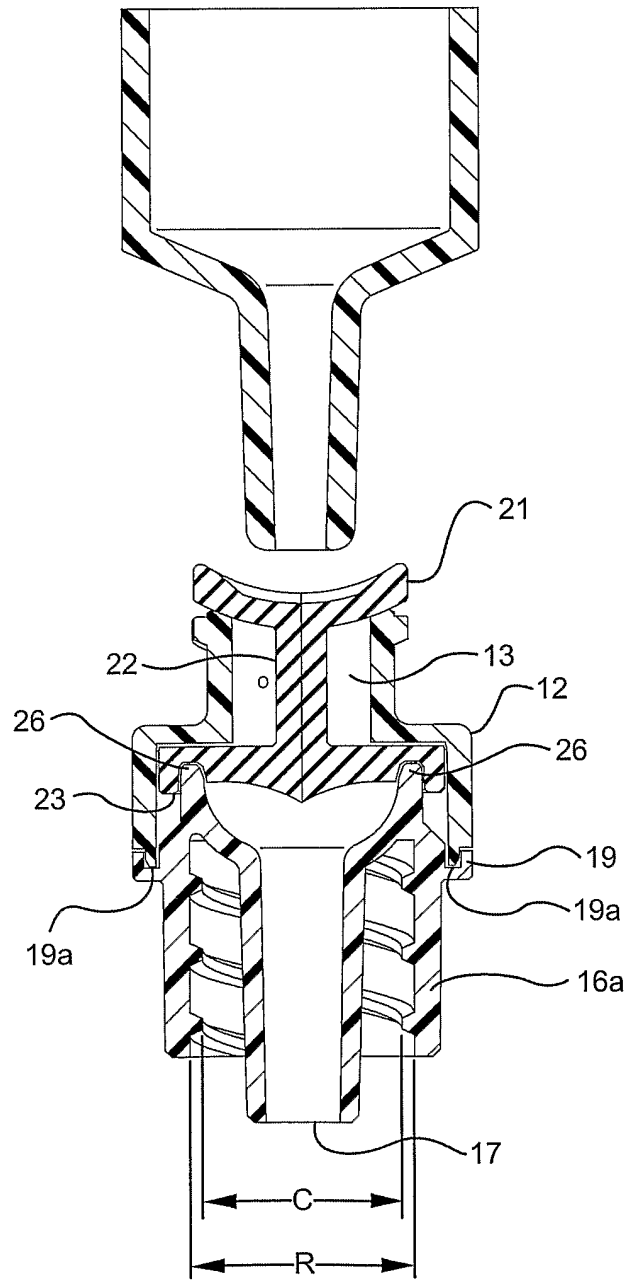
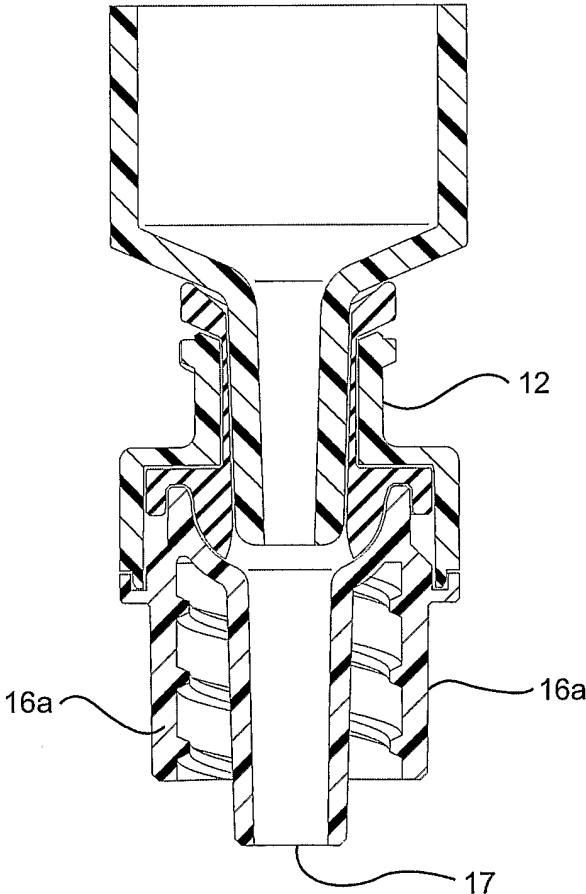

FIG. 3



5/48

FIG. 4

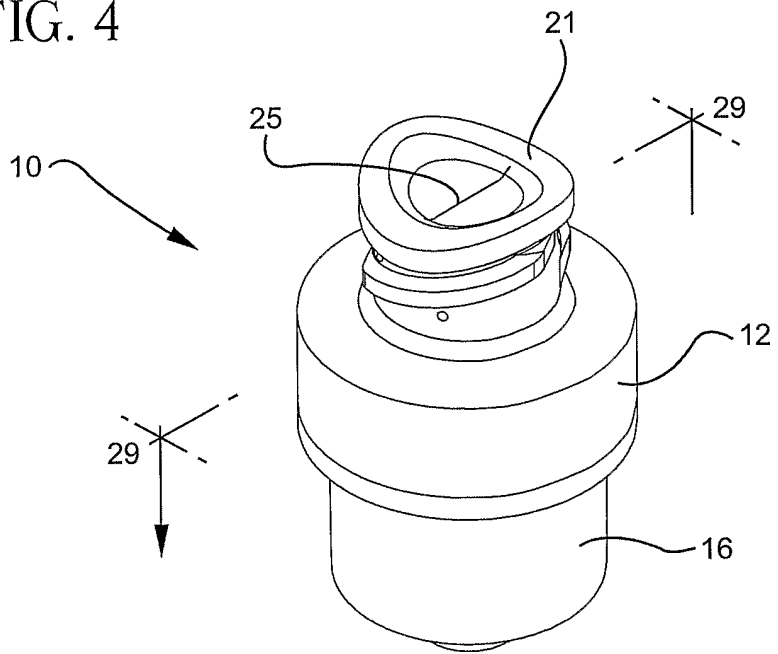

FIG. 5

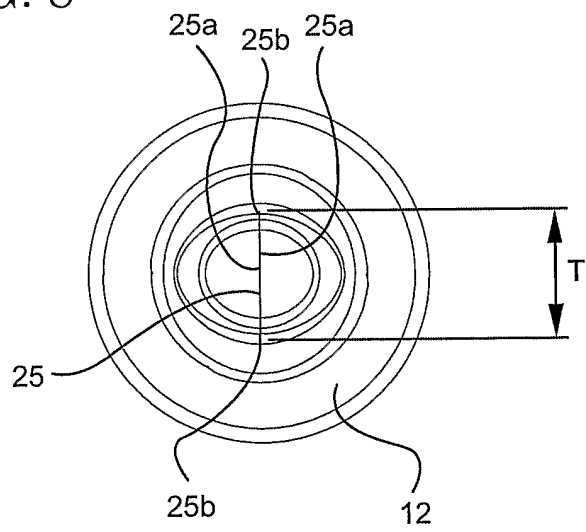

FIG. 6

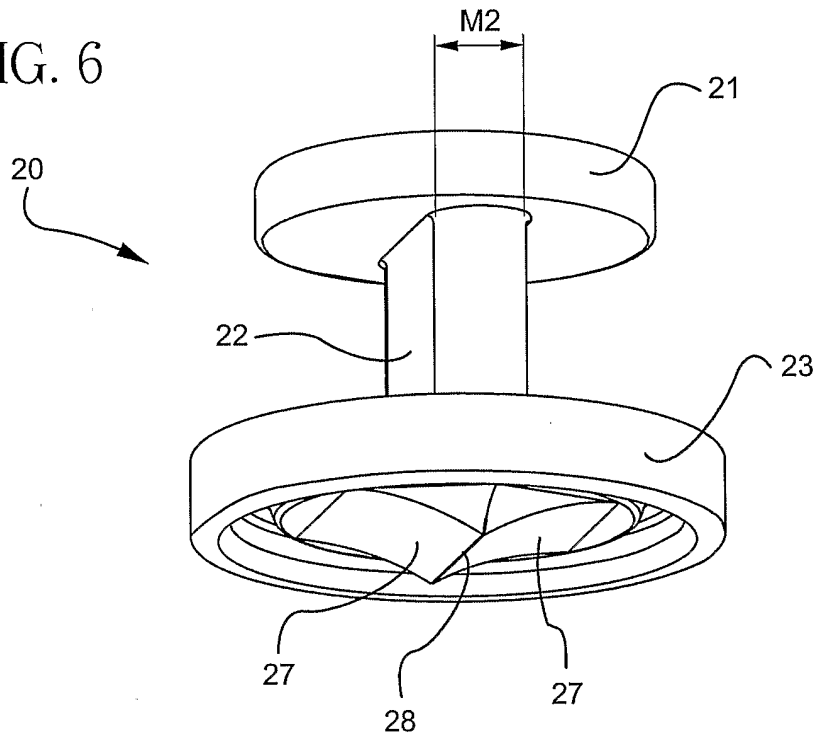

FIG. 7

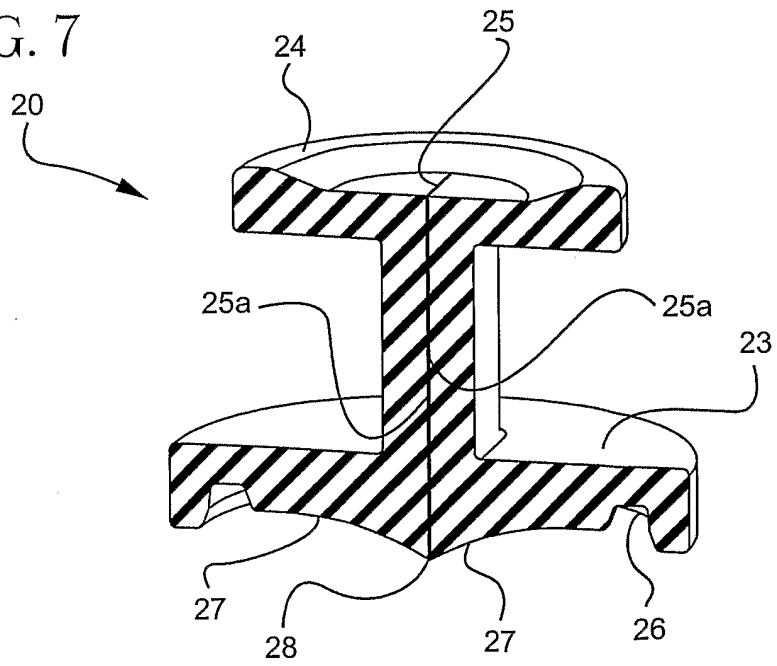

FIG. 8

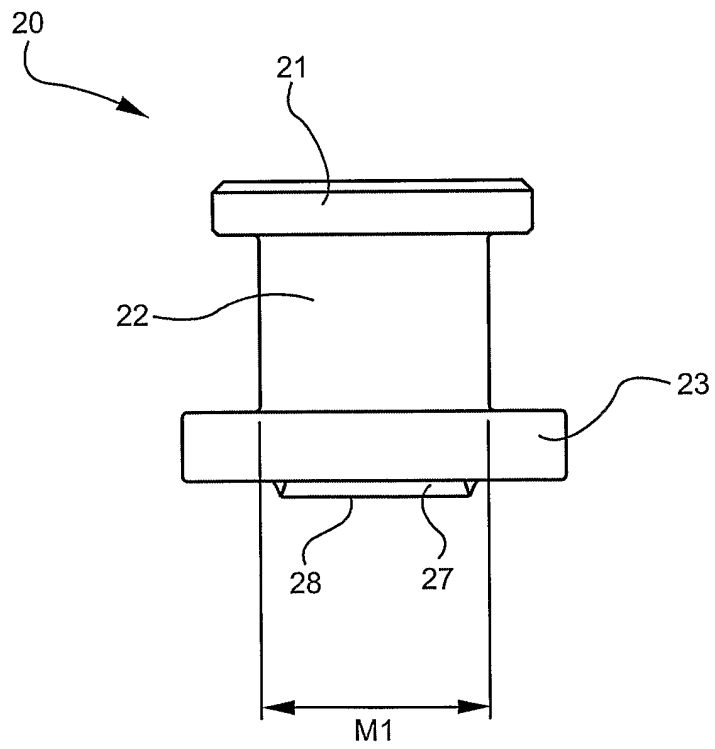

FIG. 9

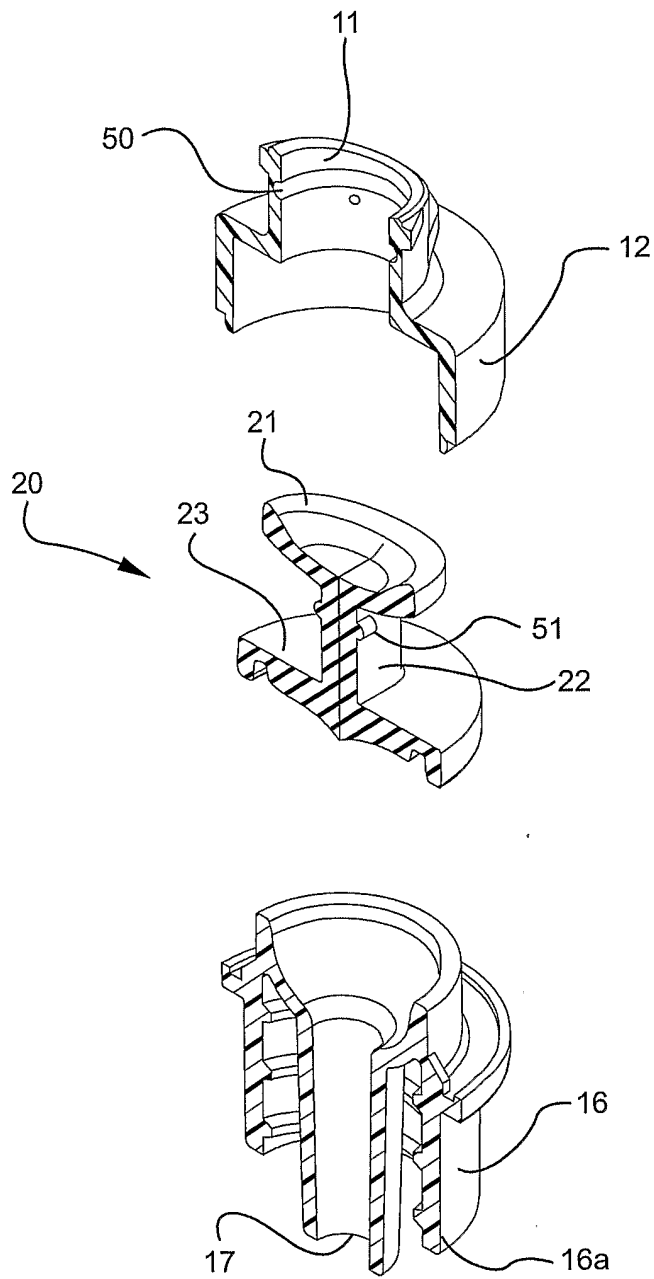

FIG. 10

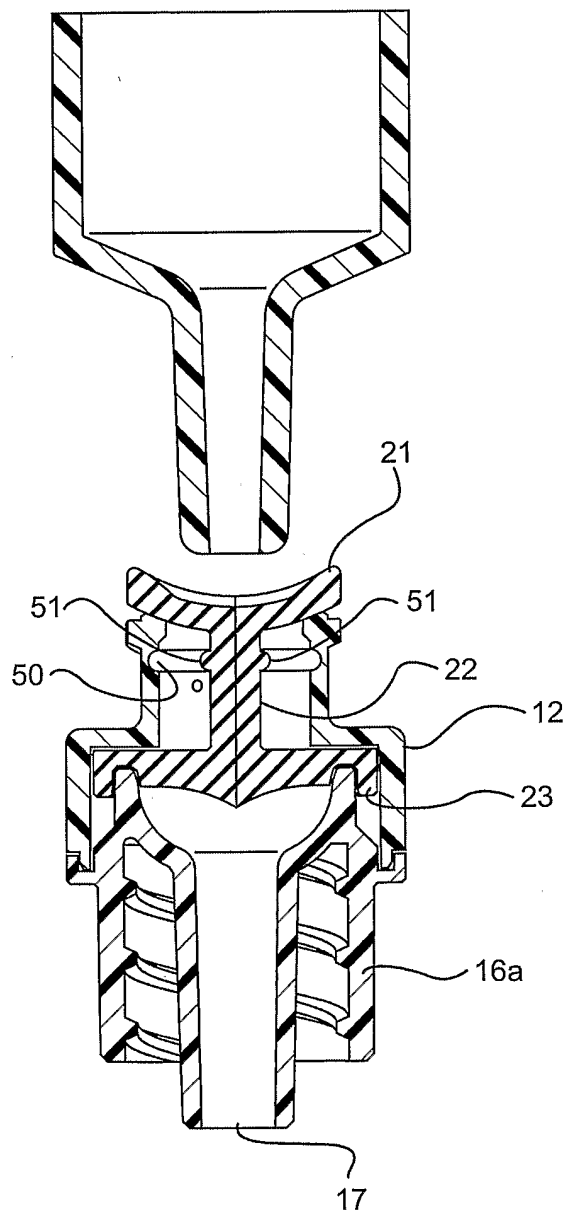

FIG. 11

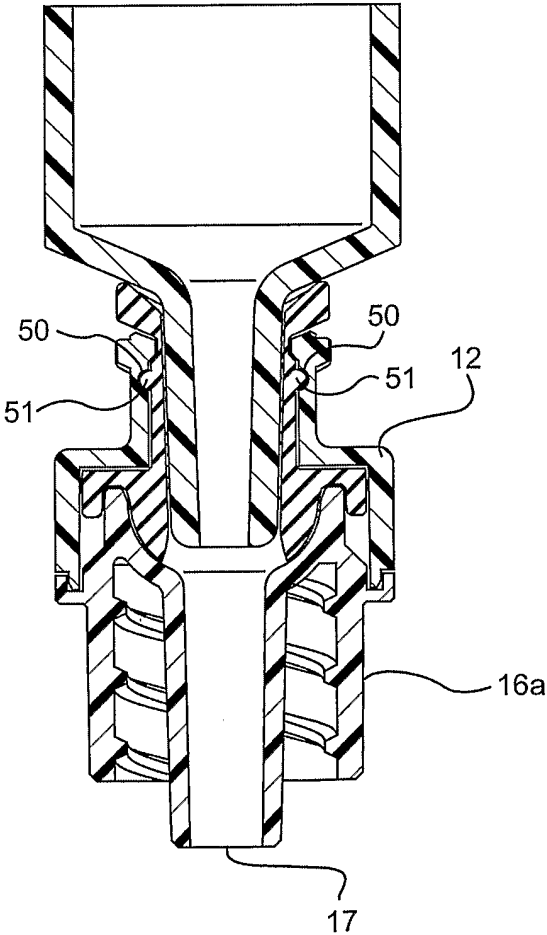

FIG. 12

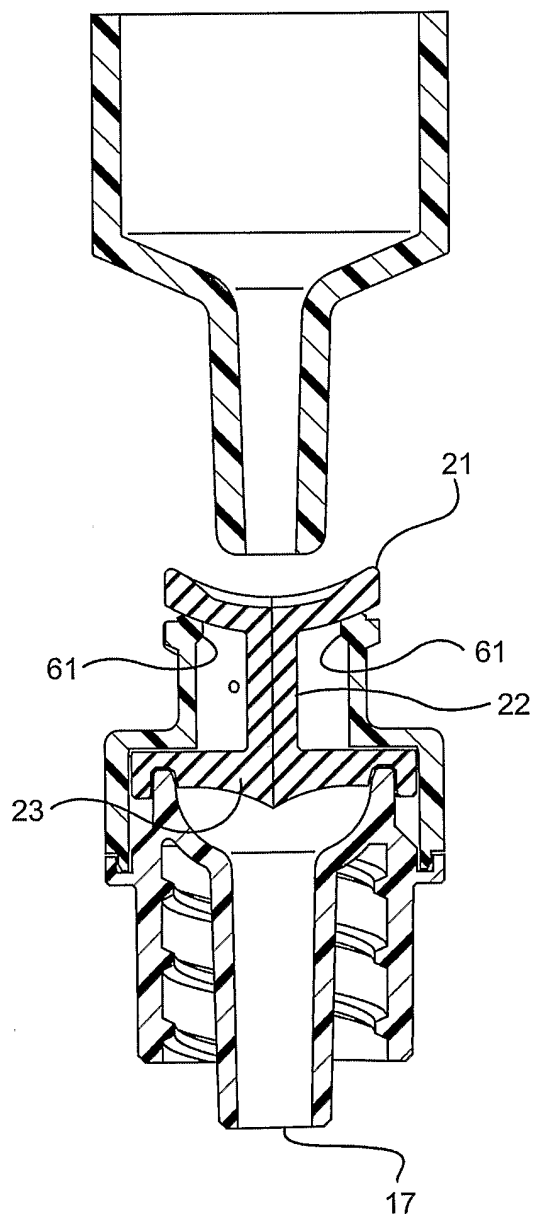

FIG. 13

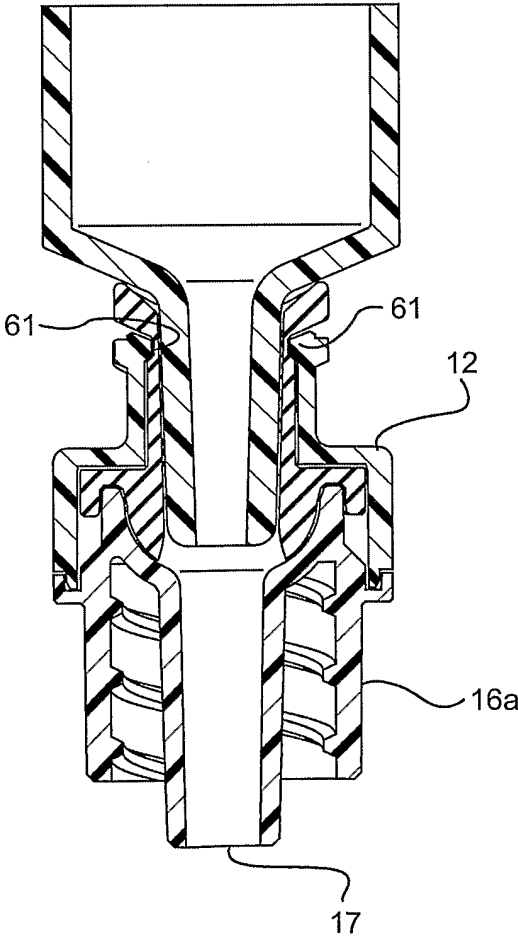

FIG. 14

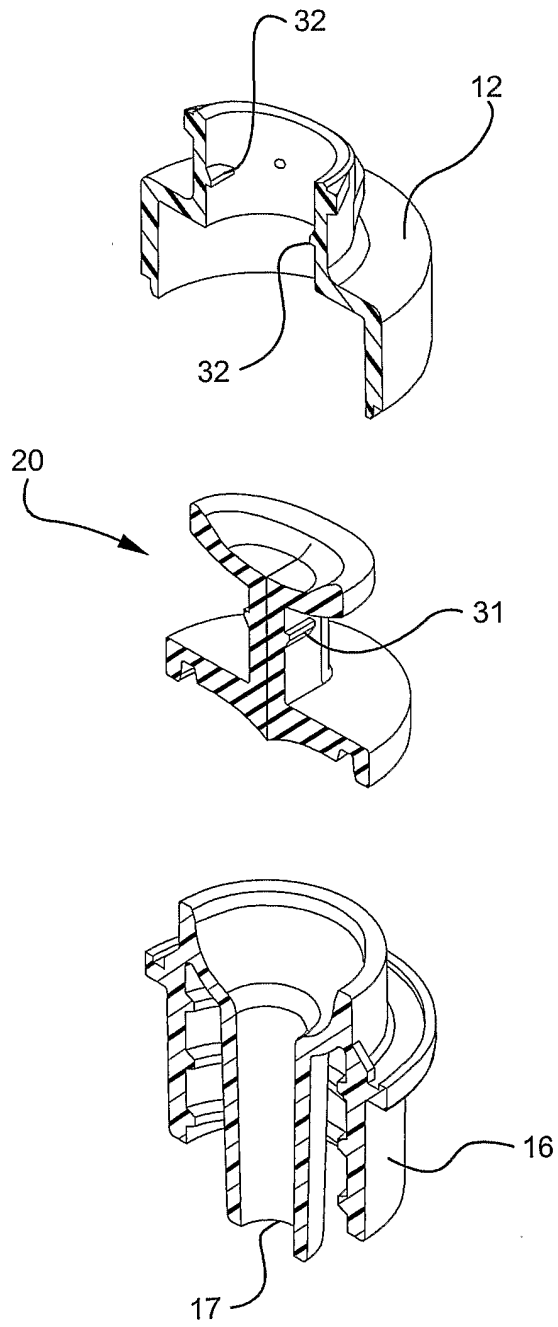

FIG. 15

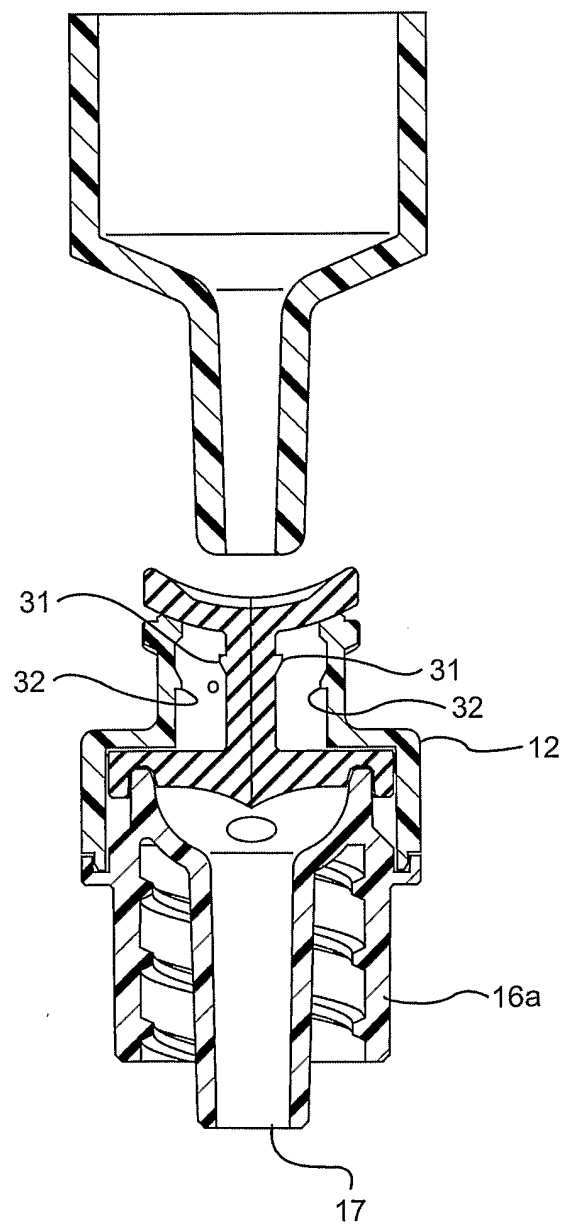

FIG. 16

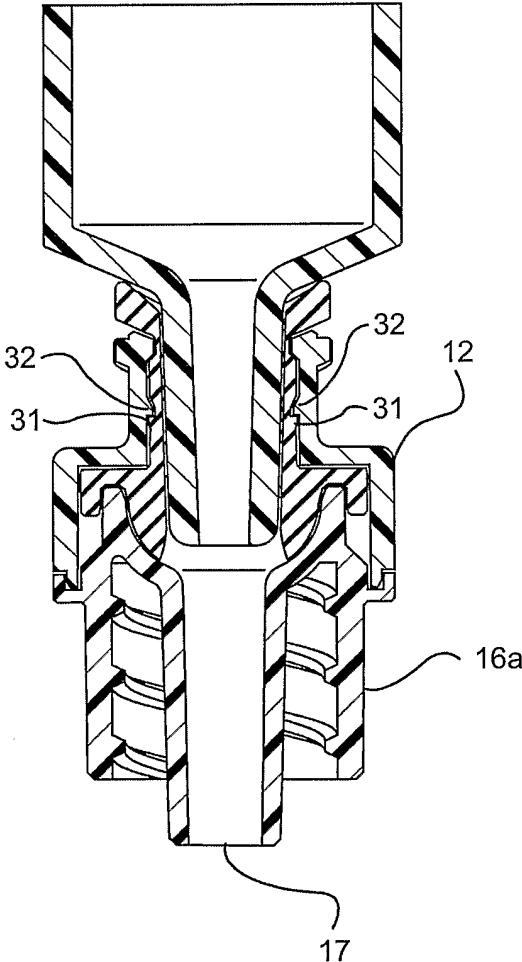

FIG. 17

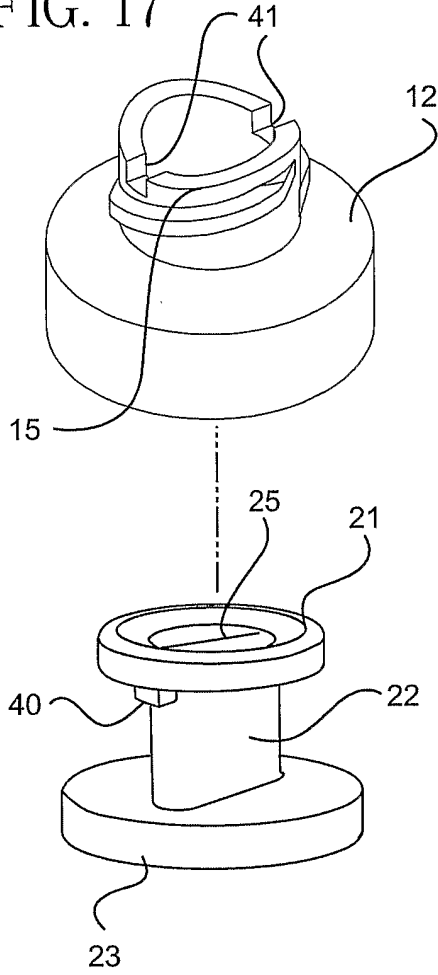
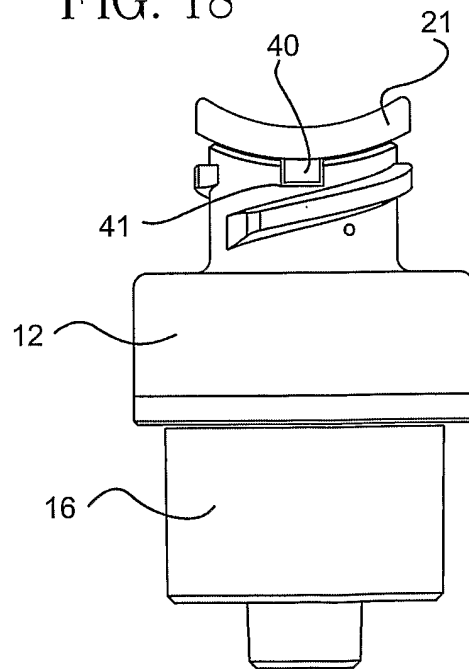

FIG. 18



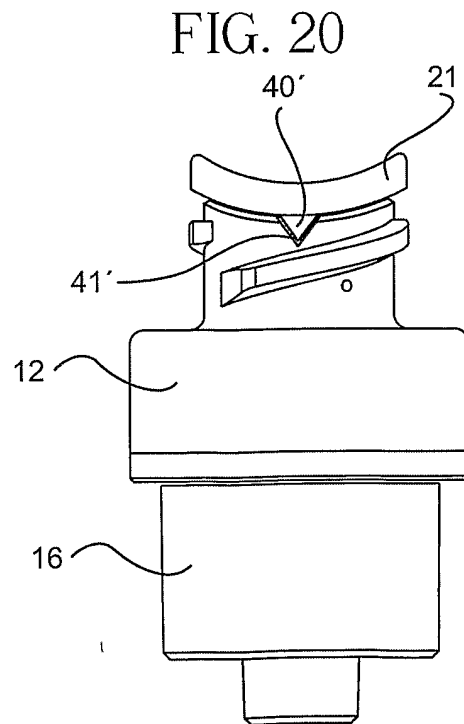
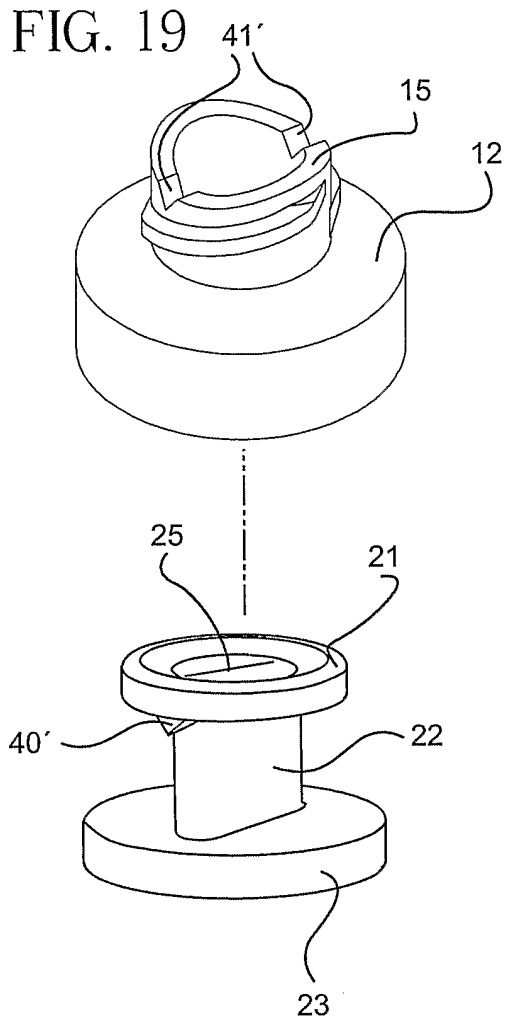

FIG. 21

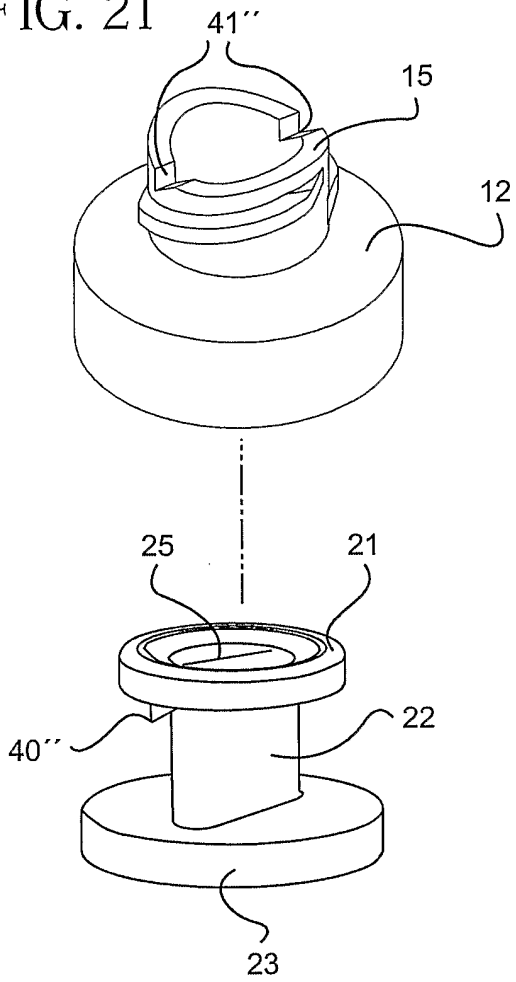

FIG. 22

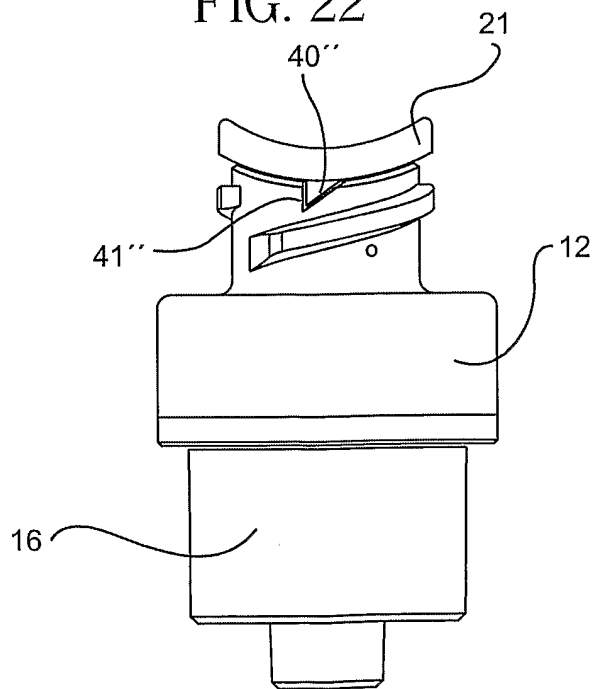

FIG. 23

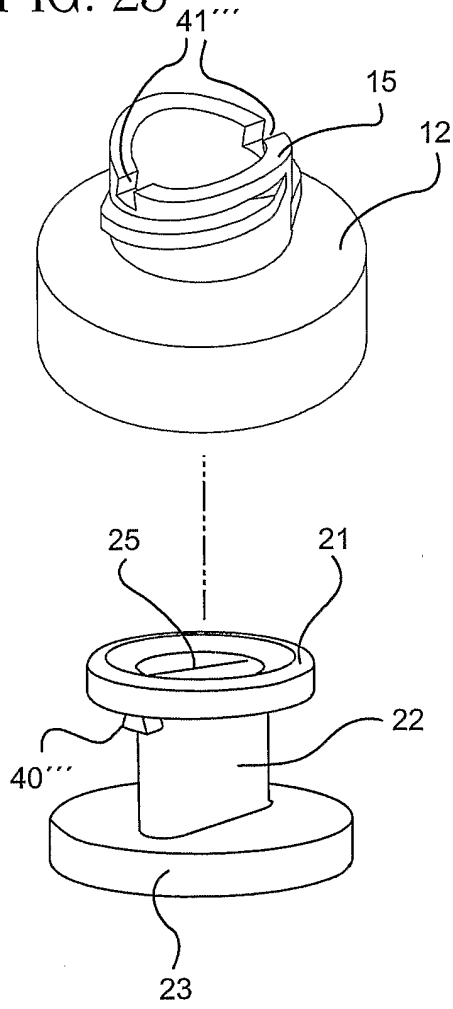

FIG. 24

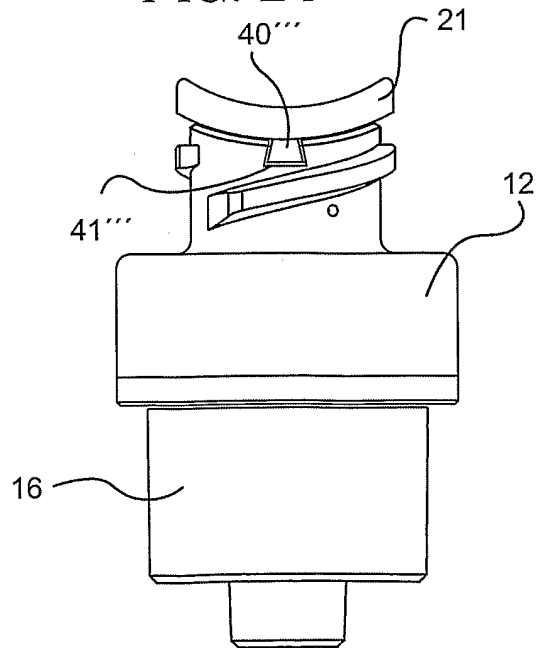

FIG. 25

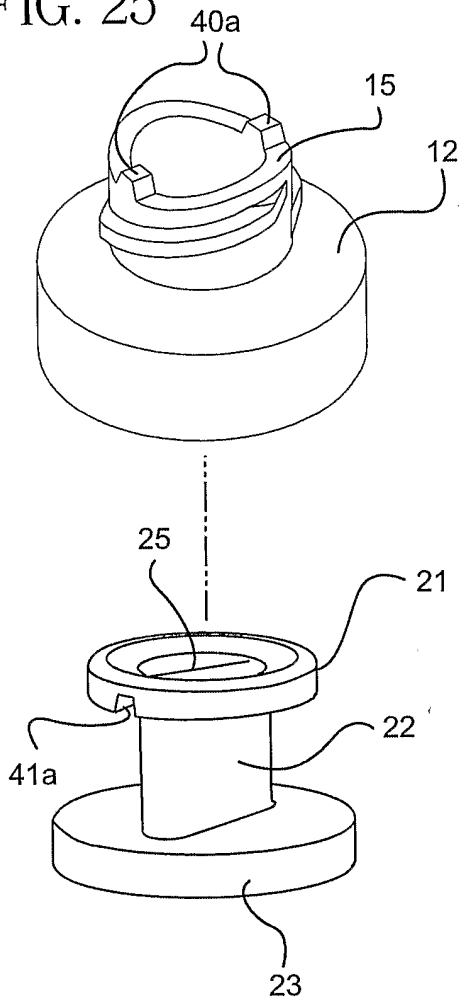
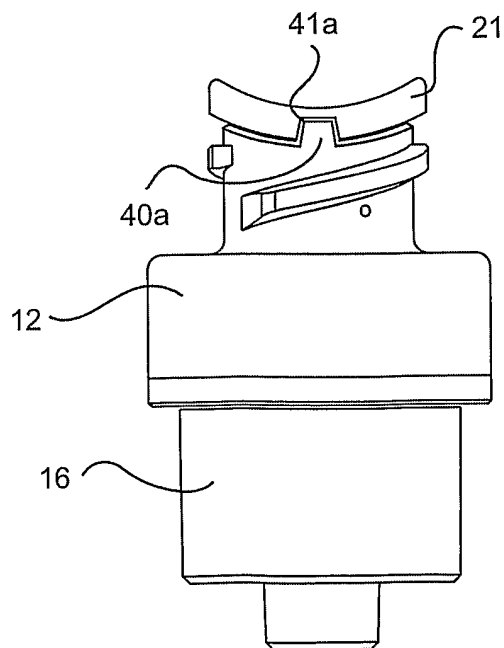

FIG. 26



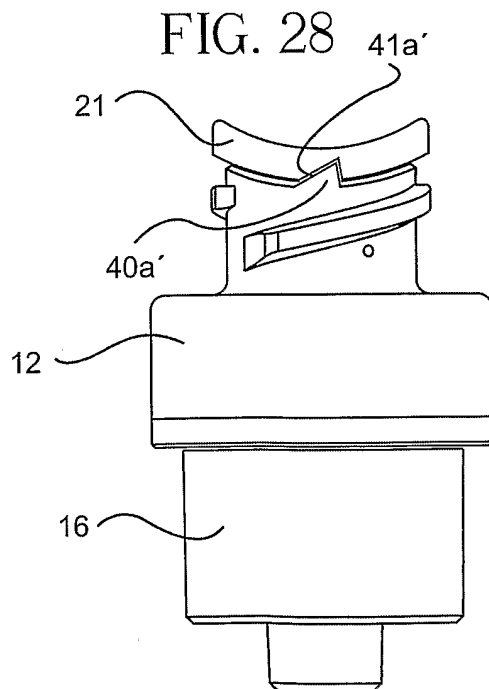
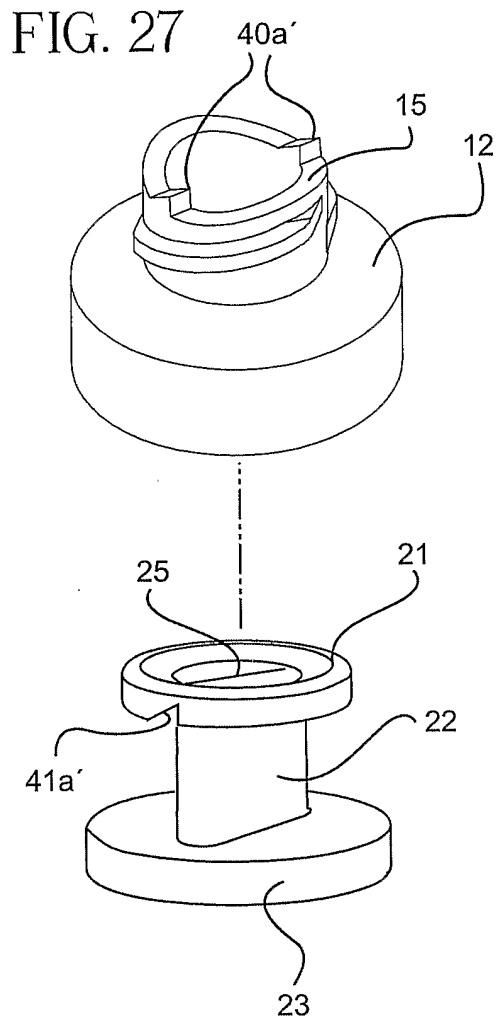

FIG. 29

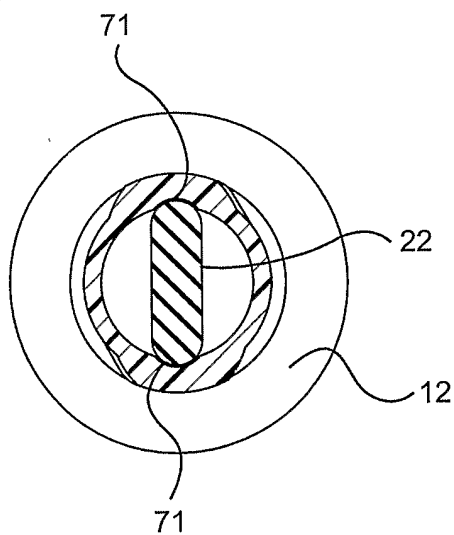

FIG. 30

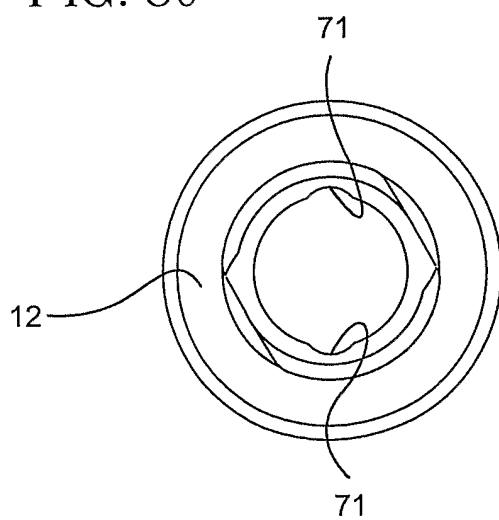

FIG. 31

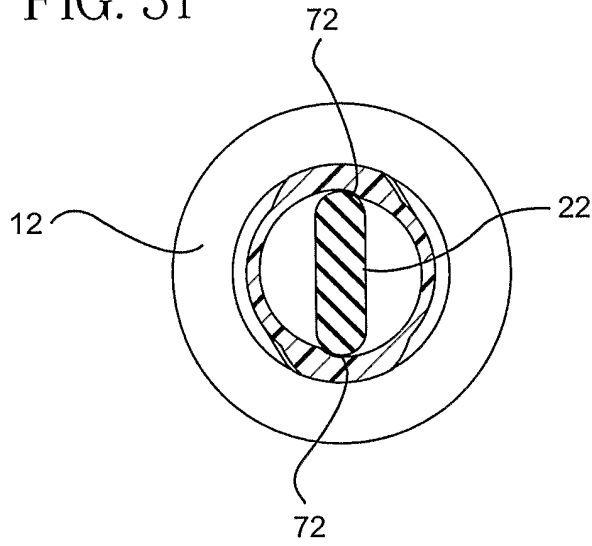

FIG. 32

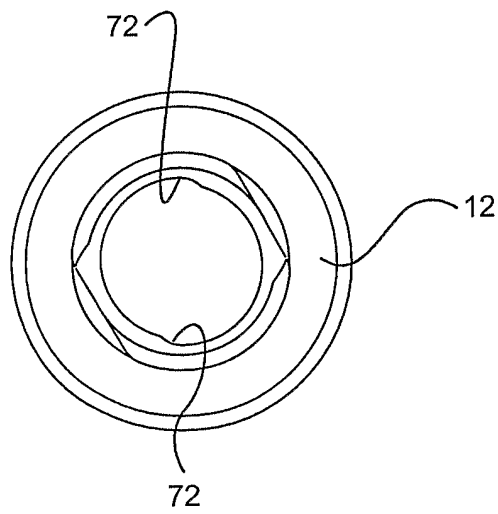

FIG. 33

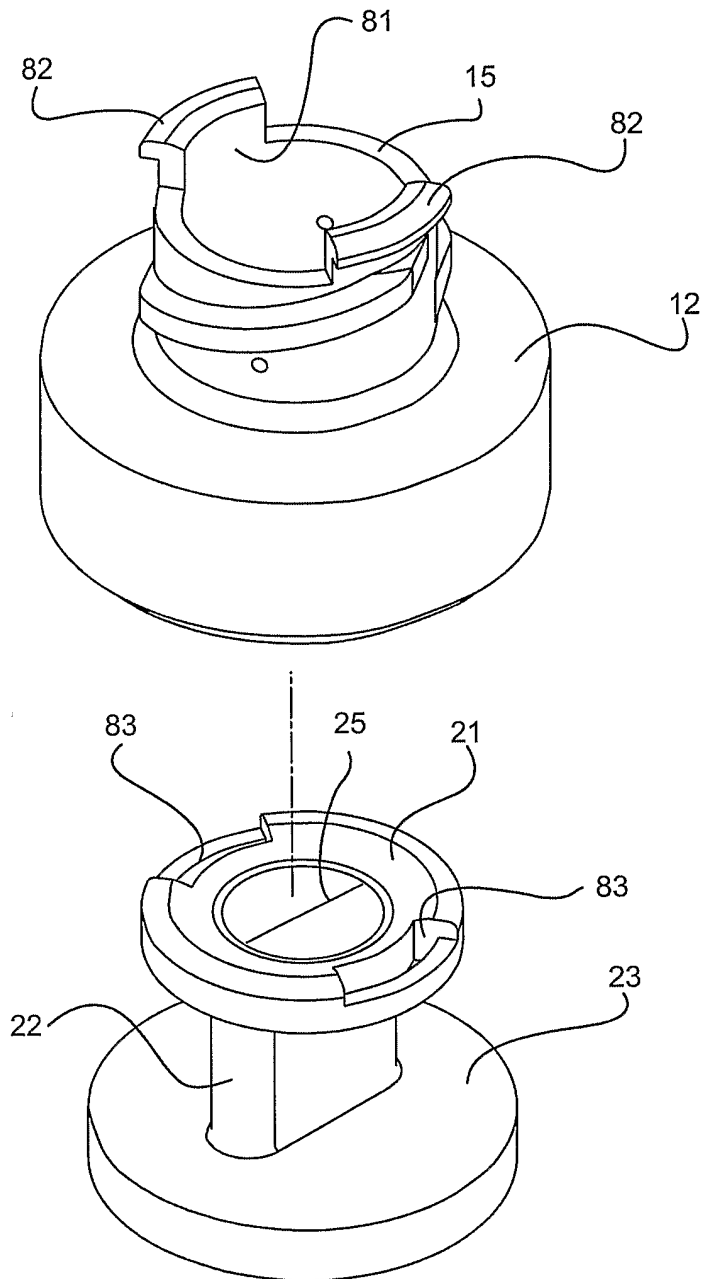
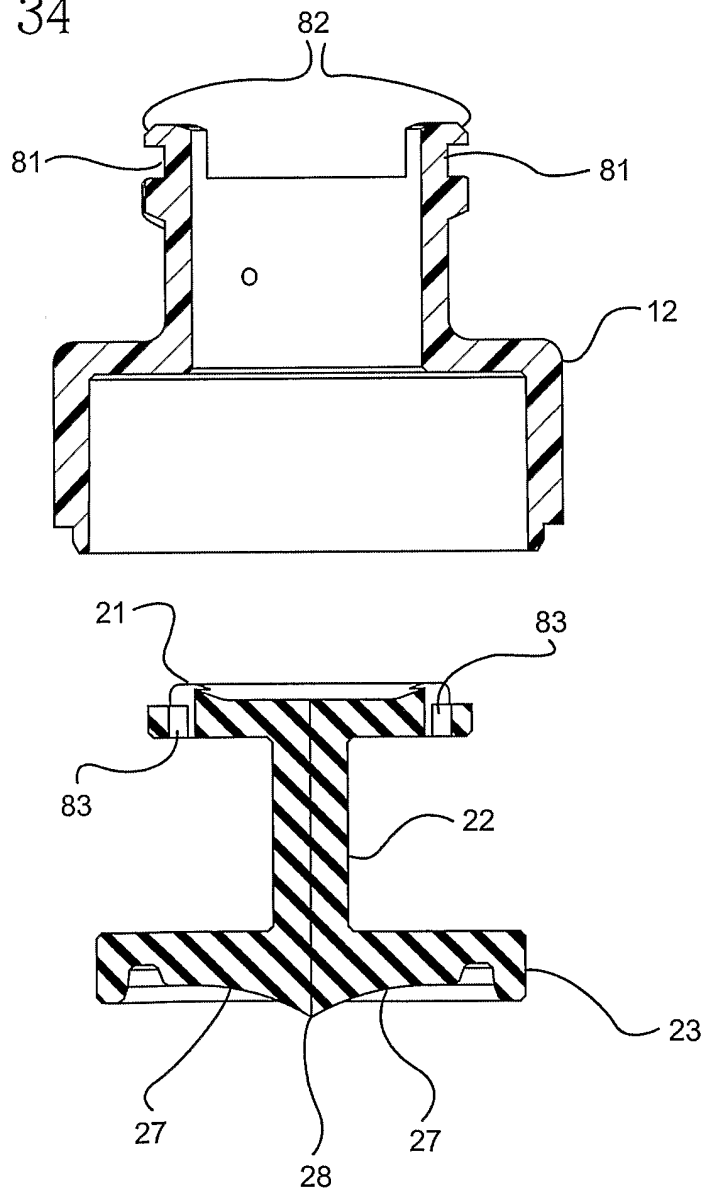

FIG. 34



26/48

FIG. 35

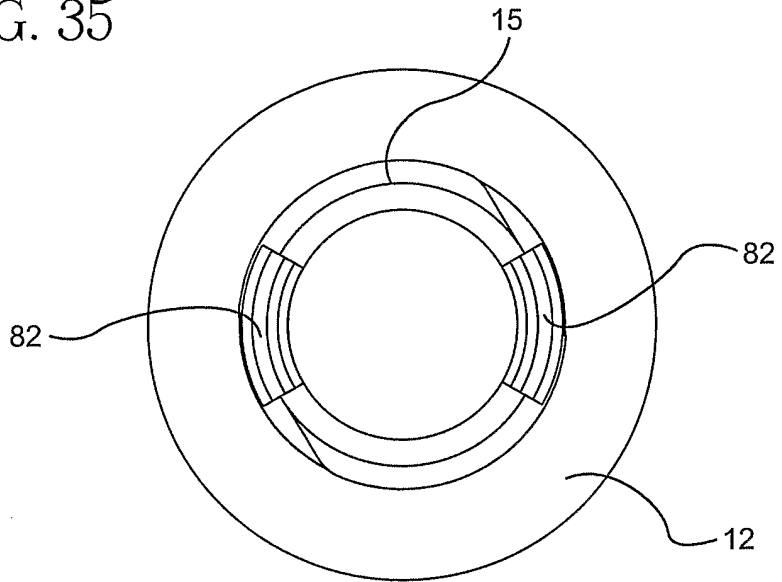

FIG. 36

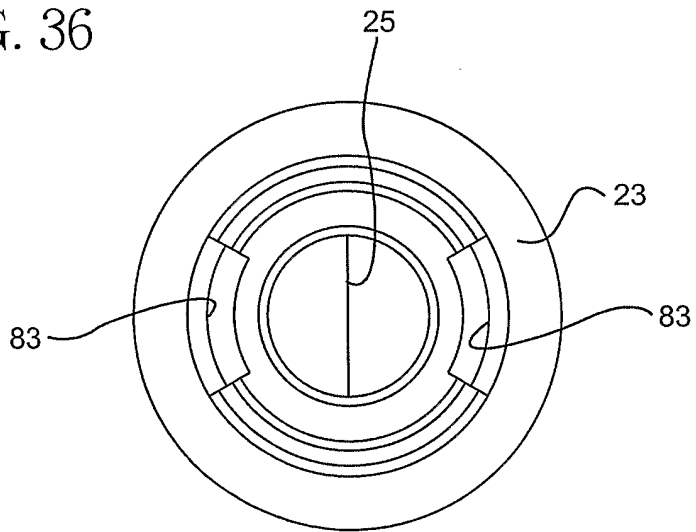

FIG. 37

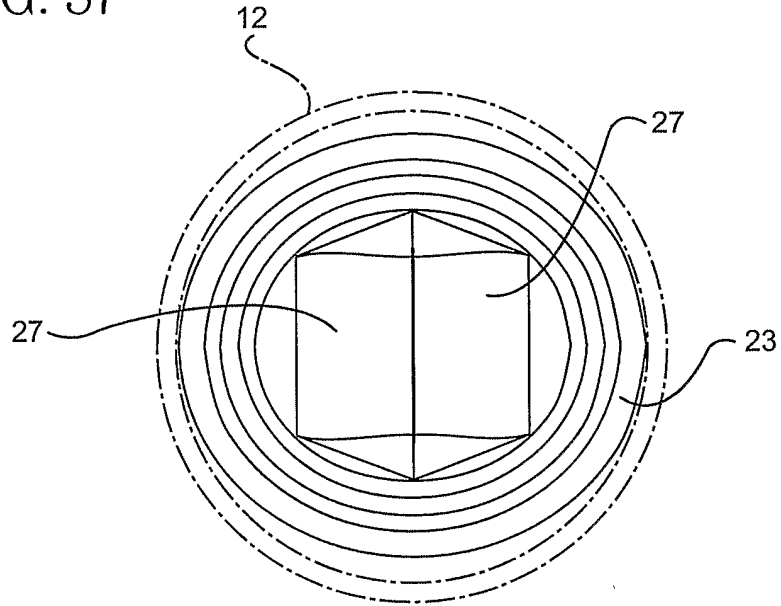
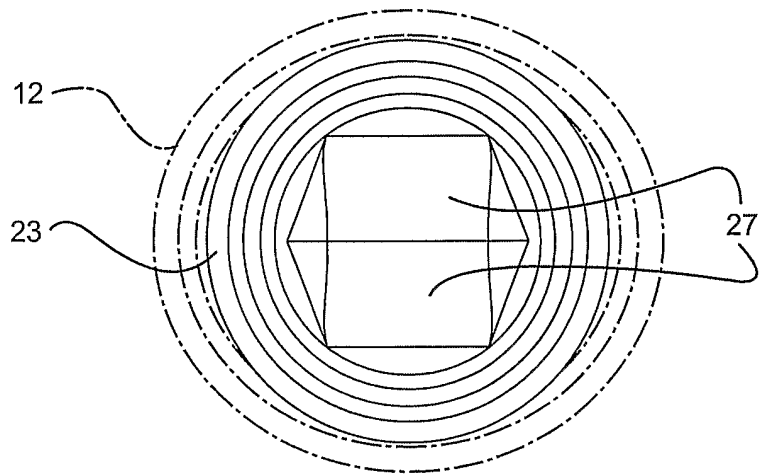

FIG. 38



28/48

FIG. 39

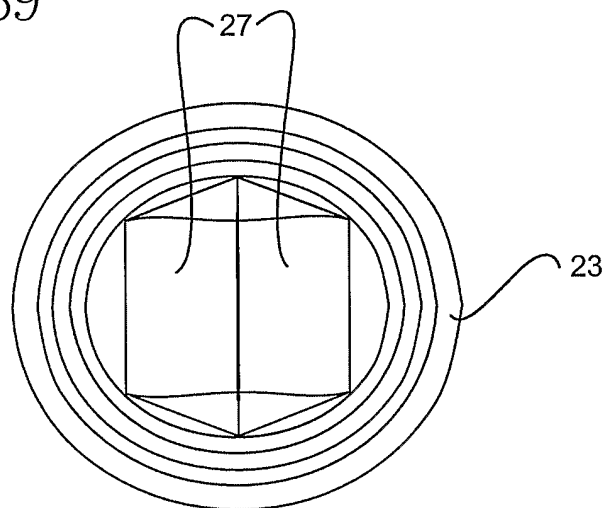

FIG. 40

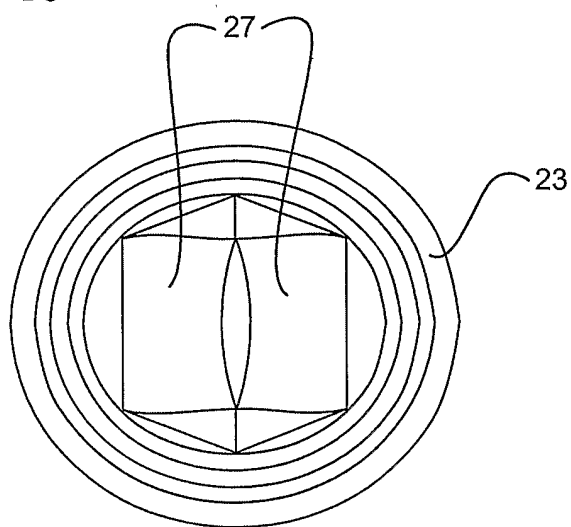

FIG. 41

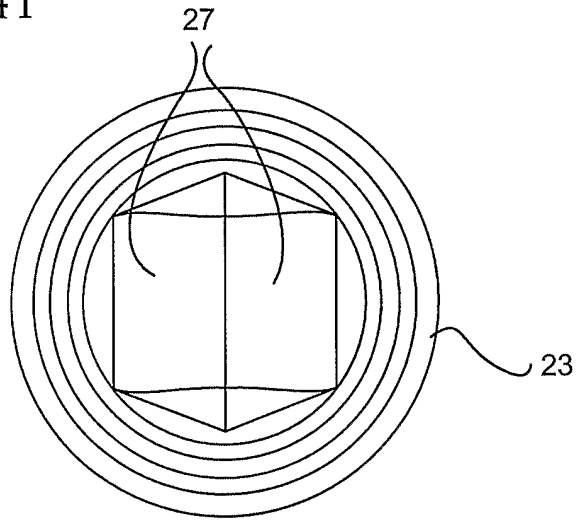

FIG. 42

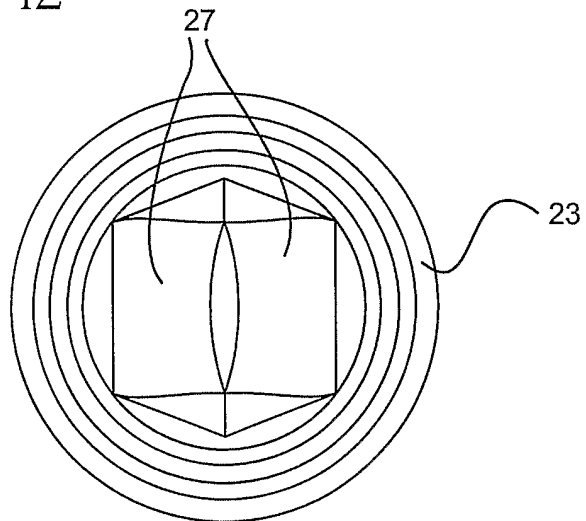

FIG. 43

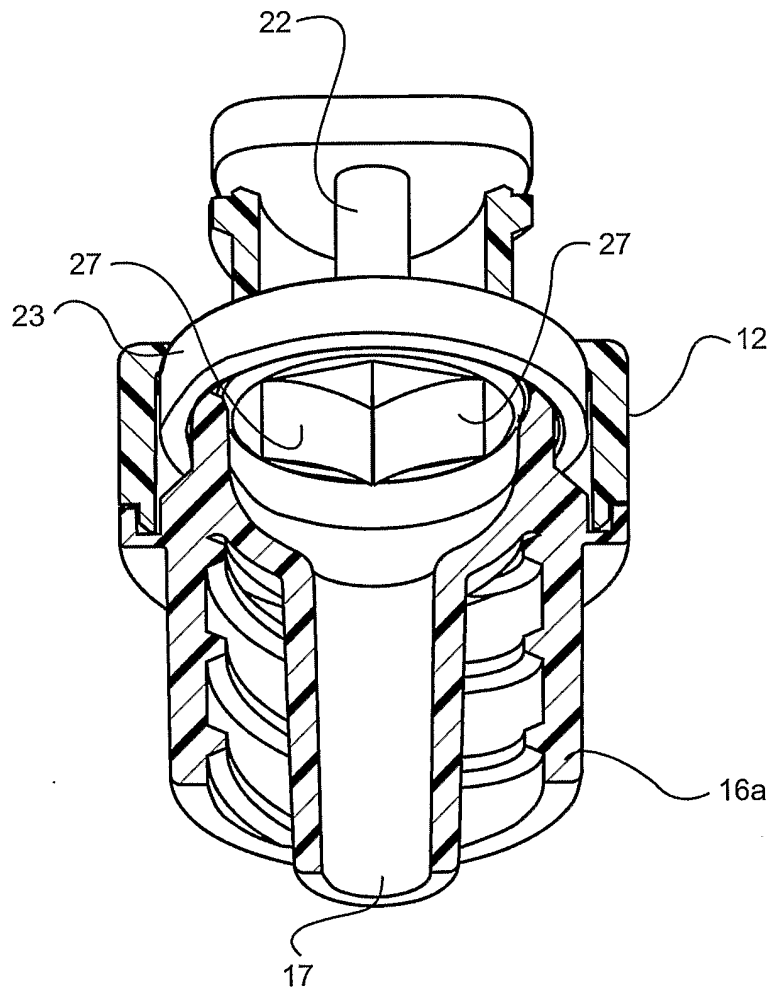

FIG. 44

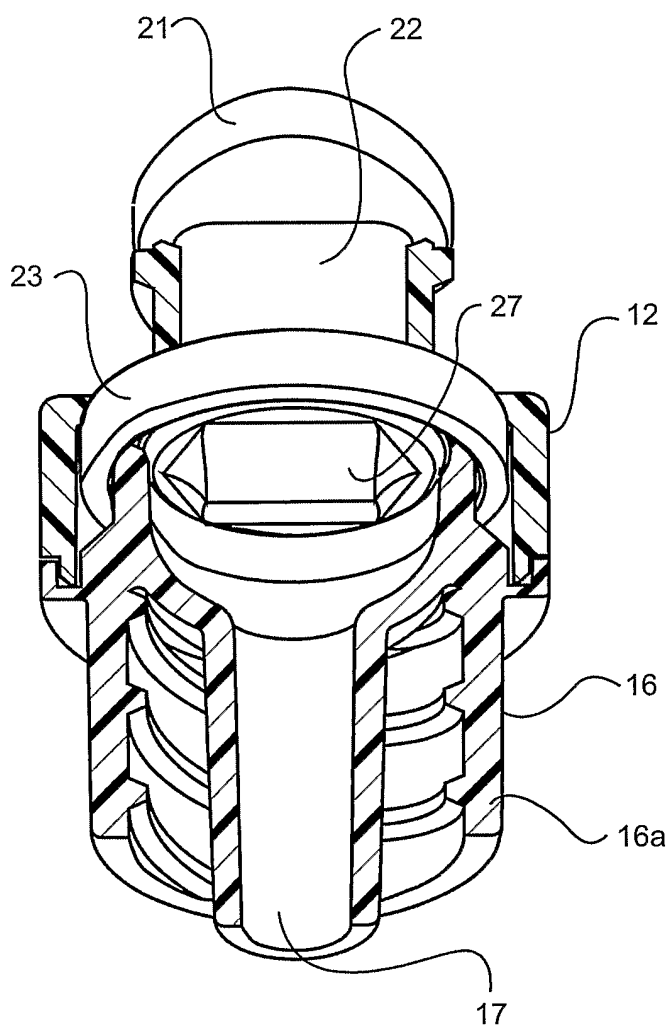

FIG. 45

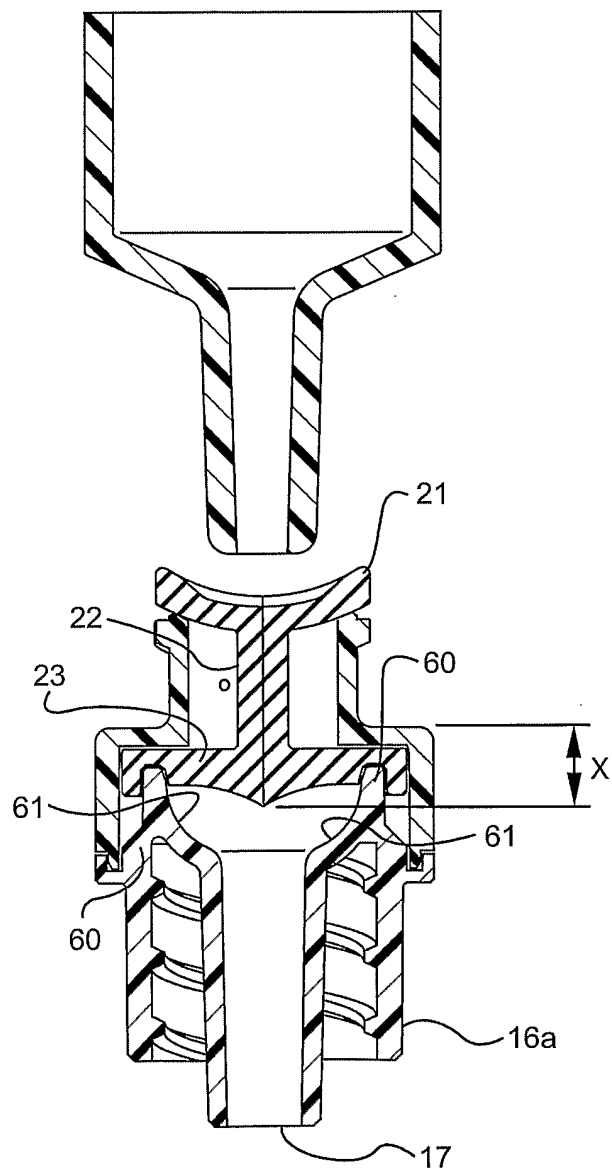

FIG. 46

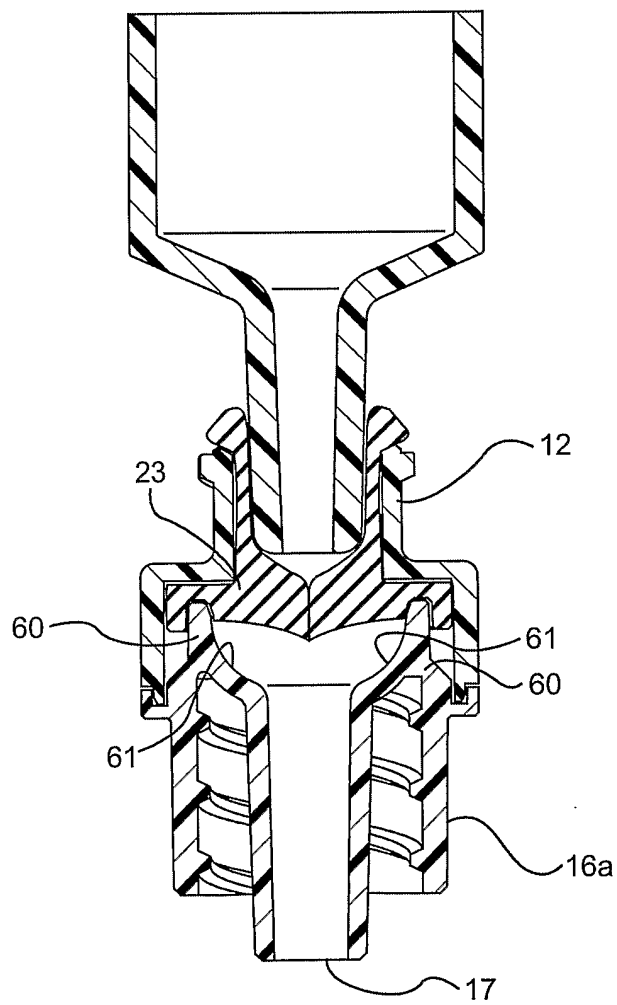

FIG. 47

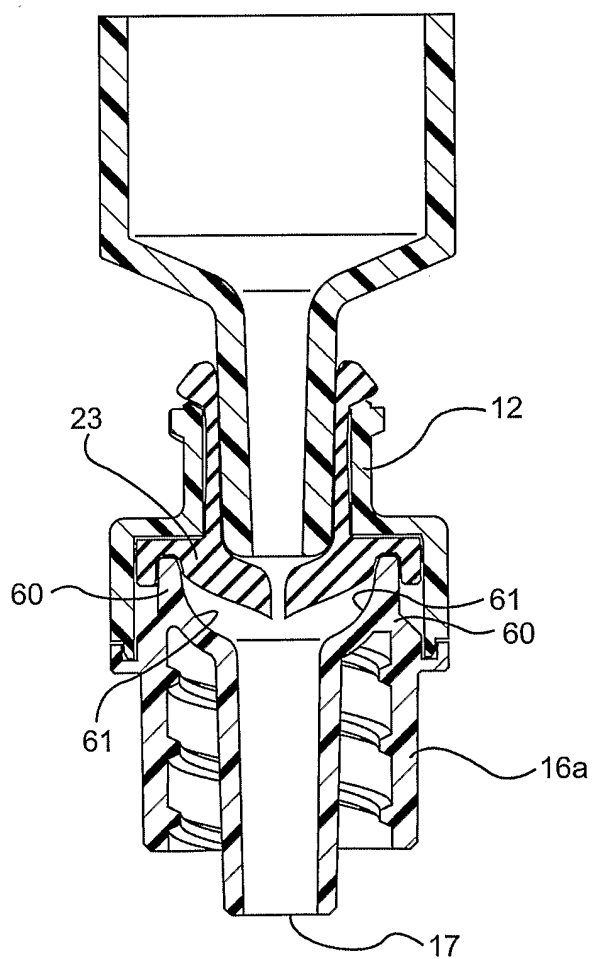

FIG. 48

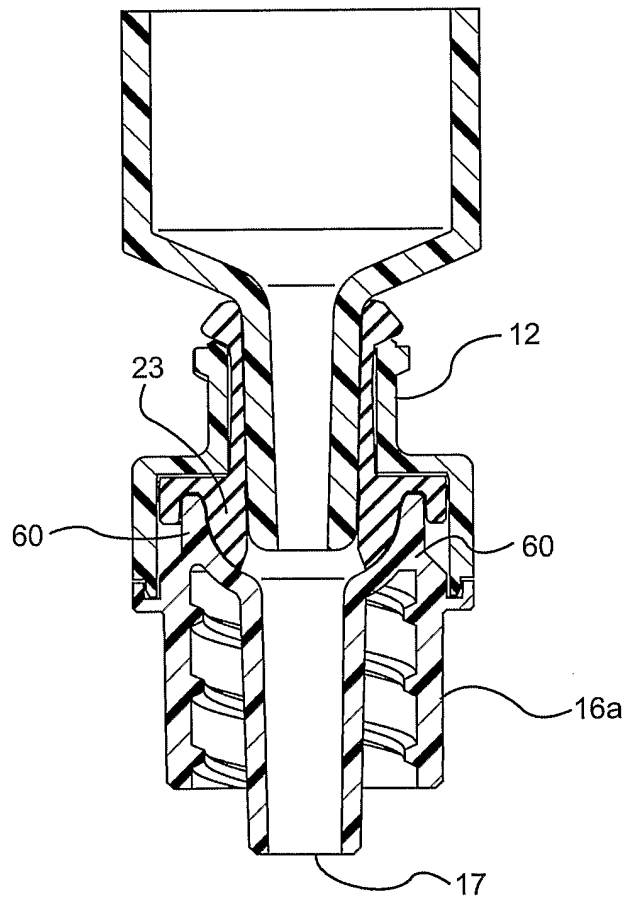
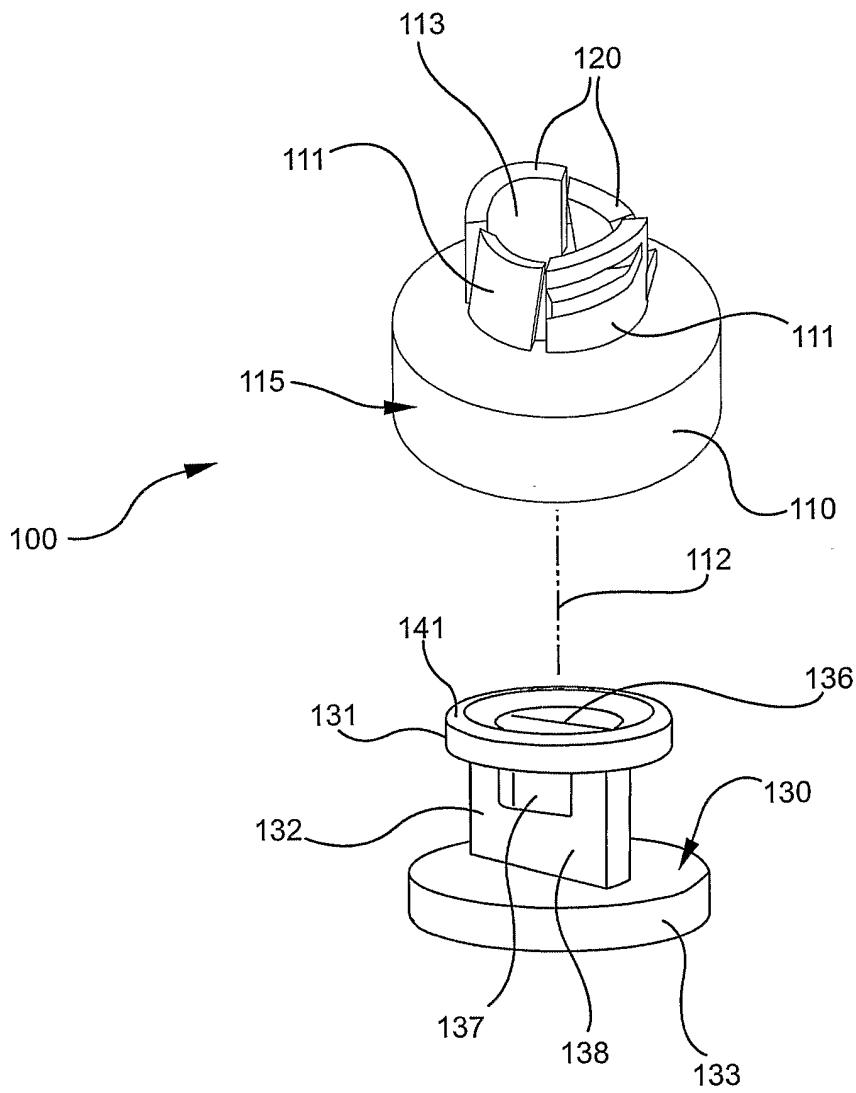

FIG. 49



37/48

FIG. 50

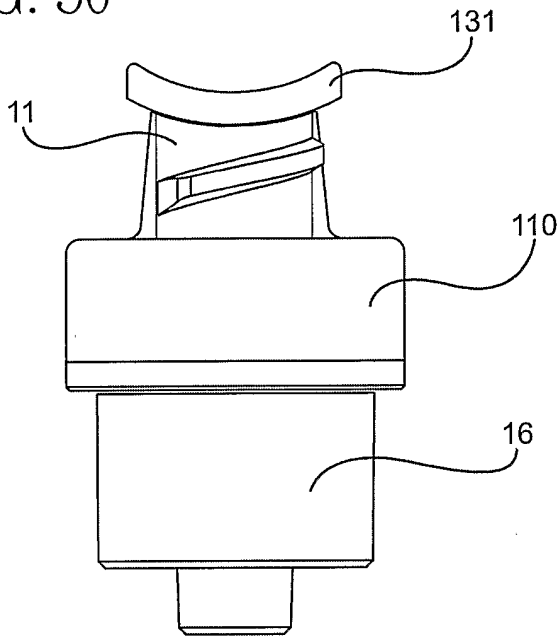

FIG. 51

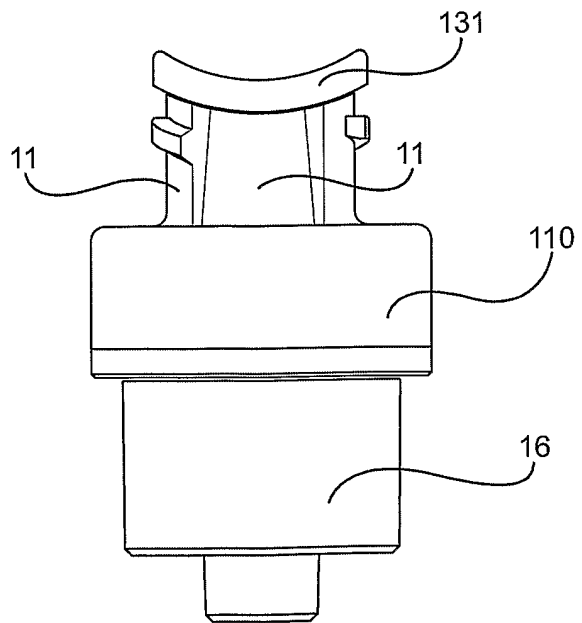

FIG. 52

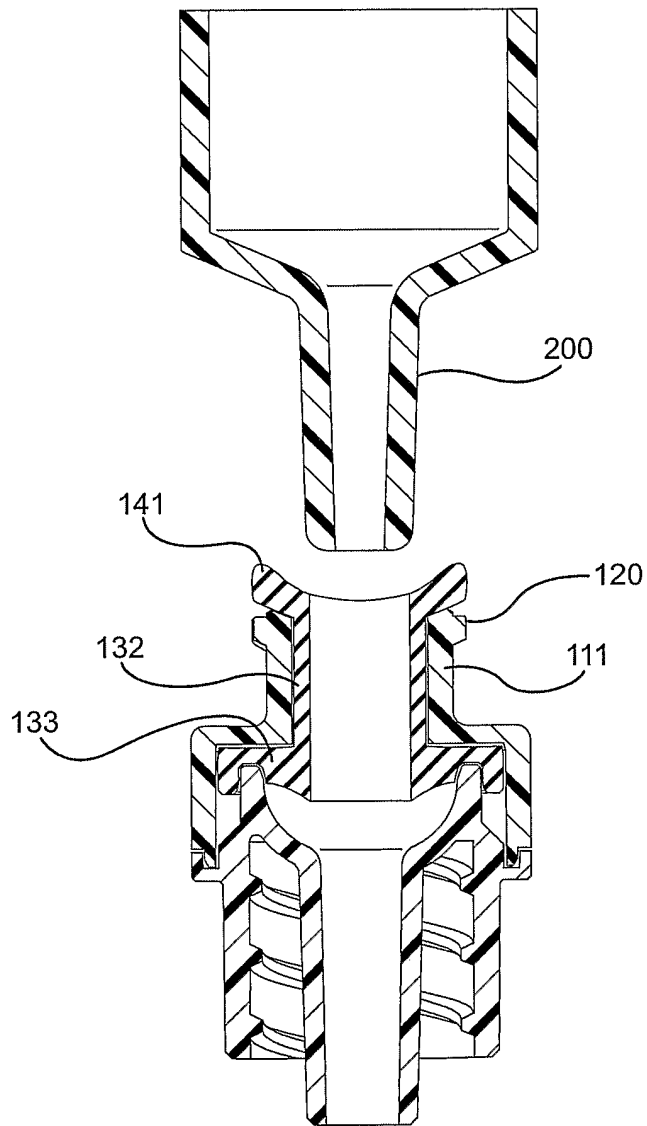

FIG. 53

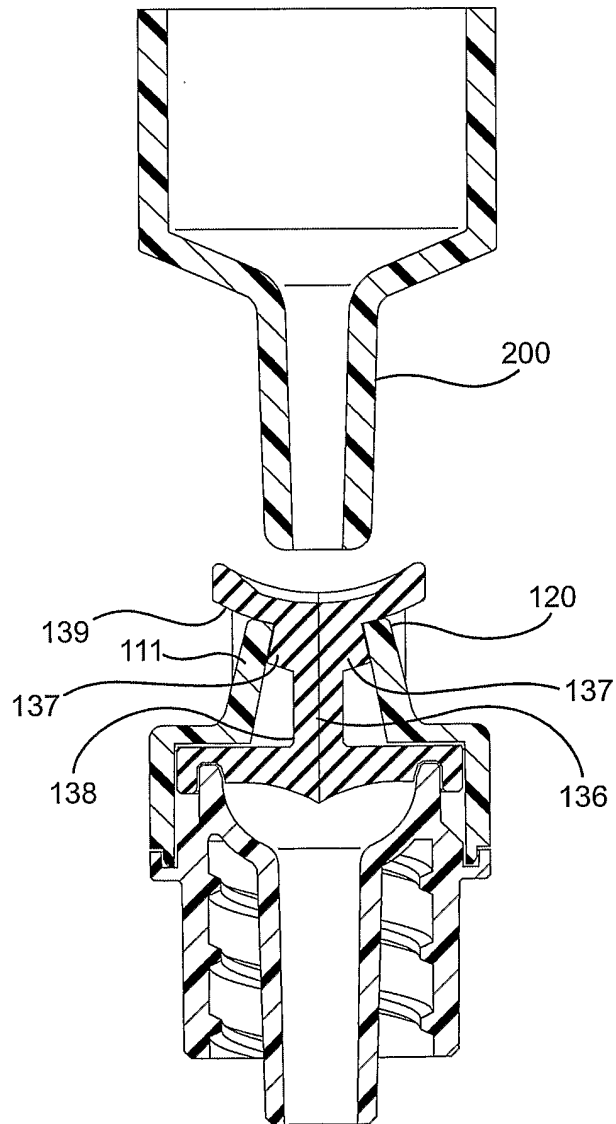

FIG. 54

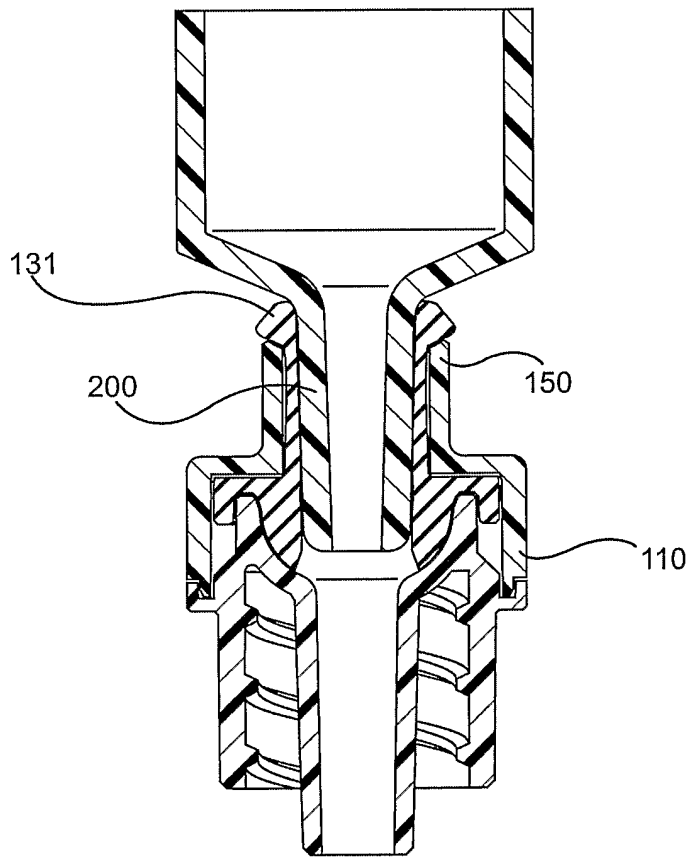

FIG. 55

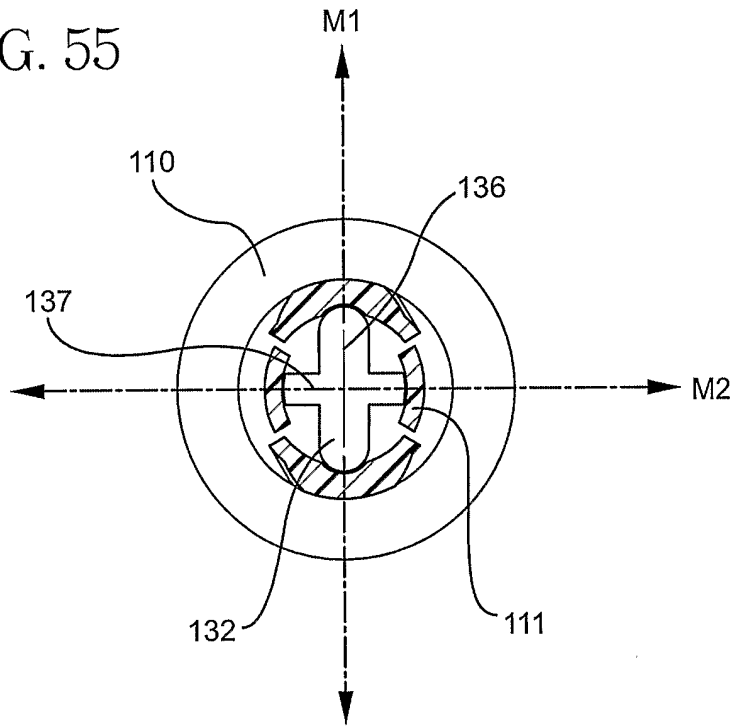

FIG. 56

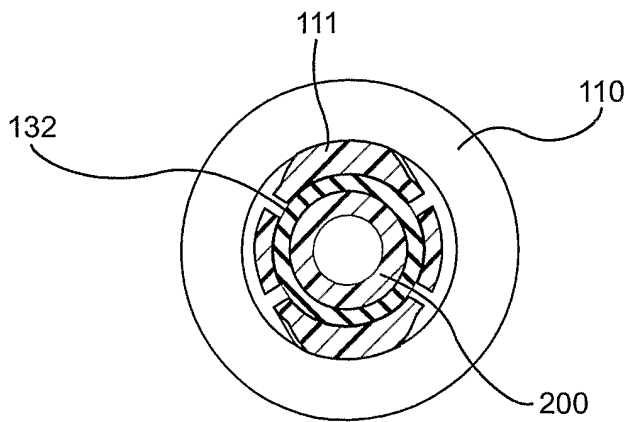

FIG. 58

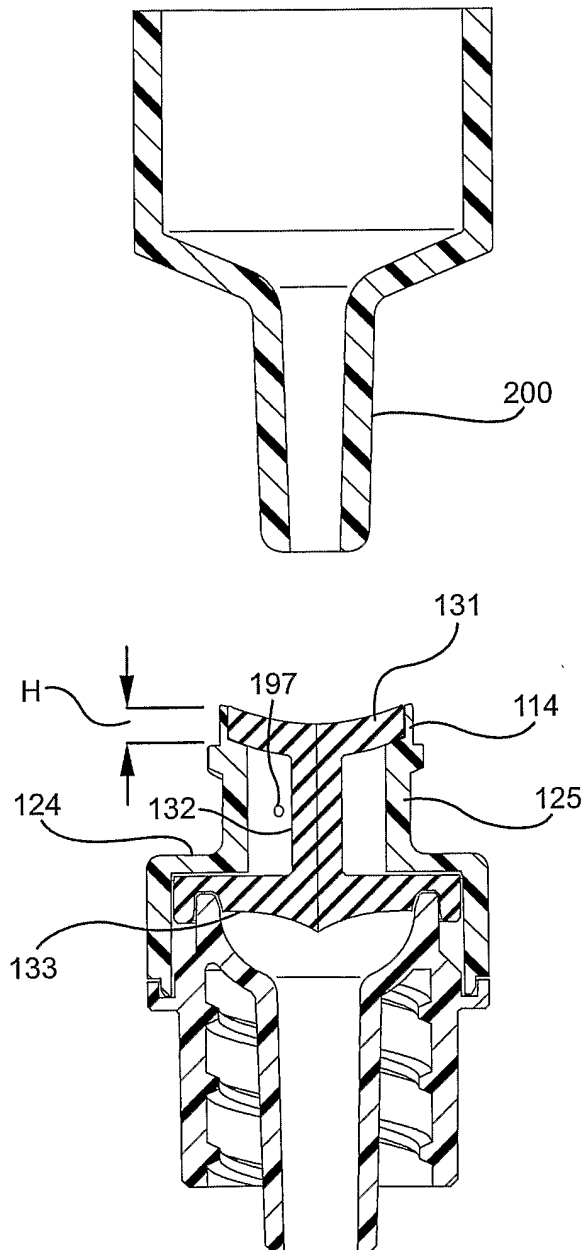

FIG. 59

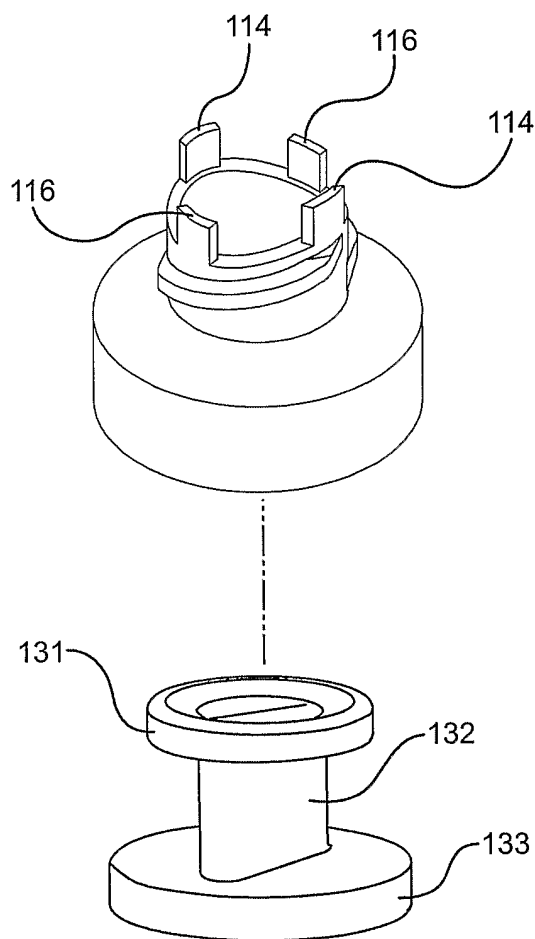

FIG. 60

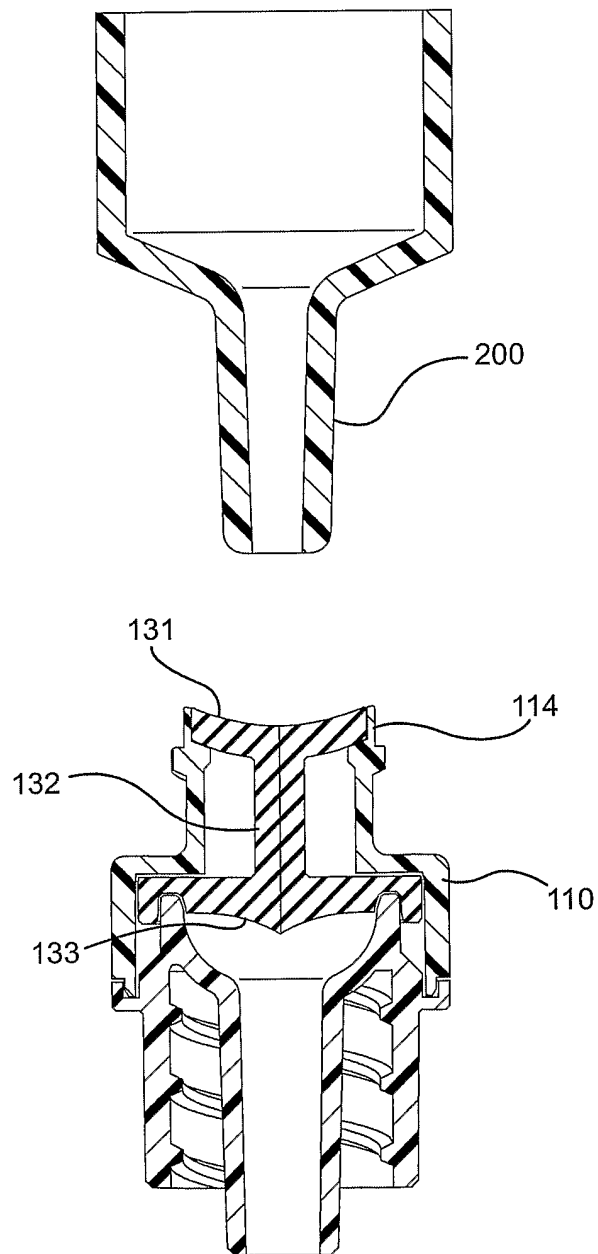

FIG. 61

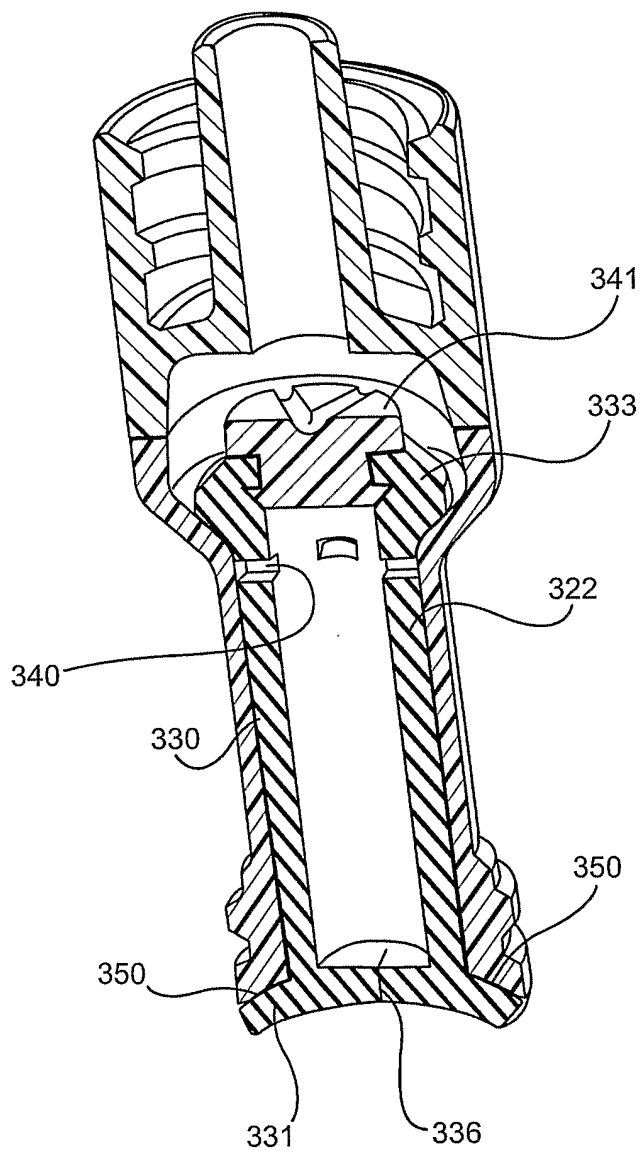

FIG. 62

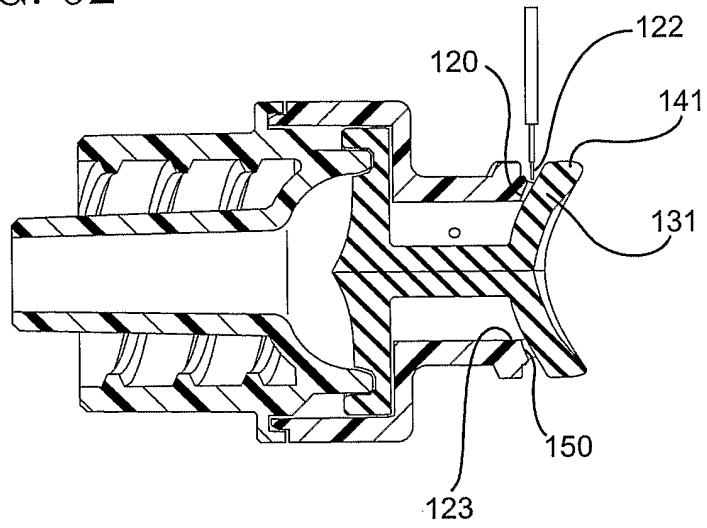

FIG. 63

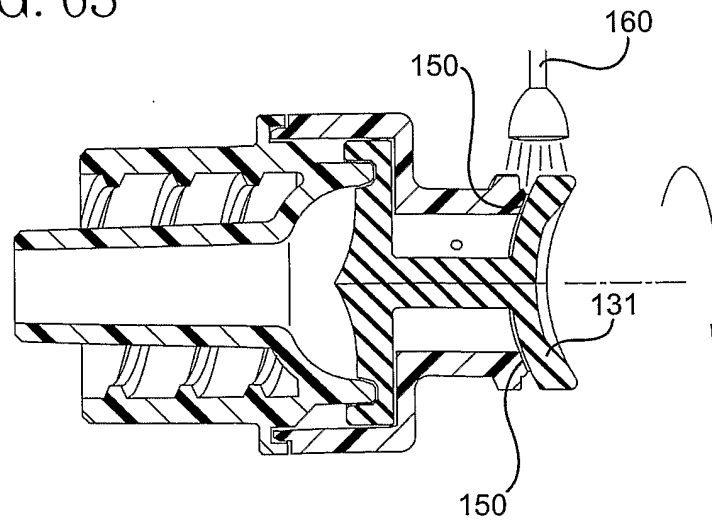
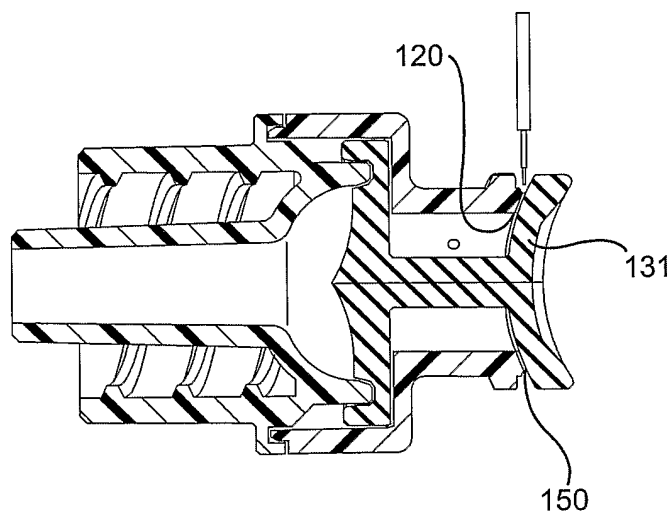

FIG. 64



INTERNATIONAL SEARCH REPORT

International Application No
PCT/US 03/12704

A. CLASSIFICATION OF SUBJECT MATTER
IPC 7 A61M39/00 A61M39/04 A61J1/00

According to International Patent Classification (IPC) or to both national classification and IPC

B. FIELDS SEARCHED
Minimum documentation searched (classification system followed by classification symbols)
IPC 7 A61M A61J

Documentation searched other than minimum documentation to the extent that such documents are included in the fields searched

Electronic data base consulted during the international search (name of data base and, where practical, search terms used)
EPO-Internal

C. DOCUMENTS CONSIDERED TO BE RELEVANT

Category °	Citation of document, with indication, where appropriate, of the relevant passages	Relevant to claim No.
A	US 6 171 287 B1 (PURDY EDMUND ROBERT ET AL) 9 January 2001 (2001-01-09) abstract; figures column 5, line 63 -column 6, line 19 column 10, line 36 -column 13, line 28 column 15, line 12-19 column 20, line 29-39	1-7
A	US 6 228 060 B1 (HOWELL GLADE H) 8 May 2001 (2001-05-08) abstract; figures column 4, line 54 -column 5, line 23	1-7
A	WO 99 61093 A (PURDY EDMUND ROBERT ;HARDING WESTON (US); LYNN LAWRENCE A (US)) 2 December 1999 (1999-12-02) abstract; figures	1-7

Further documents are listed in the continuation of box C. Patent family members are listed in annex.

° Special categories of cited documents :

- *A* document defining the general state of the art which is not considered to be of particular relevance
- *E* earlier document but published on or after the international filing date
- *L* document which may throw doubts on priority claim(s) or which is cited to establish the publication date of another citation or other special reason (as specified)
- *O* document referring to an oral disclosure, use, exhibition or other means
- *P* document published prior to the international filing date but later than the priority date claimed
- *T* later document published after the international filing date or priority date and not in conflict with the application but cited to understand the principle or theory underlying the invention
- *X* document of particular relevance; the claimed invention cannot be considered novel or cannot be considered to involve an inventive step when the document is taken alone
- *Y* document of particular relevance; the claimed invention cannot be considered to involve an inventive step when the document is combined with one or more other such documents, such combination being obvious to a person skilled in the art.
- *Z* document member of the same patent family

Date of the actual completion of the international search 24 July 2003	Date of mailing of the international search report 06/08/2003
--	---

Name and mailing address of the ISA European Patent Office, P.B. 5818 Patentlaan 2 NL - 2280 HV Rijswijk Tel. (+31-70) 340-2040, Tx. 31 651 epo nl, Fax: (+31-70) 340-3016	Authorized officer Lager, J
--	---------------------------------------

INTERNATIONAL SEARCH REPORT

International Application No
PCT/US 03/12704

C.(Continuation) DOCUMENTS CONSIDERED TO BE RELEVANT

Category °	Citation of document, with indication, where appropriate, of the relevant passages	Relevant to claim No.
A	US 6 344 033 B1 (BINDOKAS ALGIRDAS J ET AL) 5 February 2002 (2002-02-05) abstract; figures ---	
A	US 5 807 348 A (ZINGER FREDDY ET AL) 15 September 1998 (1998-09-15) abstract; figures ---	
E	WO 03 049802 A (BECTON DICKINSON CO) 19 June 2003 (2003-06-19) the whole document -----	1-7

FURTHER INFORMATION CONTINUED FROM PCT/ISA/ 210

Continuation of Box I.2

Claims Nos.: 8-48

Claims 1, 8, 14, 25, 32, 37 and 44 have been drafted as independent claims and have at least partly overlapping scope. Such a plurality of independent claims with overlapping scope makes it difficult or even impossible to clearly determine the subject-matter for which protection is sought, so that the claims as a whole fail to comply with the clarity and conciseness requirements of Article 6 PCT.

Consequently, only the subject-matter being regarded as clear and concise, namely independent claim 1 and dependent claims 2-7 have been searched.

The applicant's attention is drawn to the fact that claims, or parts of claims, relating to inventions in respect of which no international search report has been established need not be the subject of an international preliminary examination (Rule 66.1(e) PCT). The applicant is advised that the EPO policy when acting as an International Preliminary Examining Authority is normally not to carry out a preliminary examination on matter which has not been searched. This is the case irrespective of whether or not the claims are amended following receipt of the search report or during any Chapter II procedure.

INTERNATIONAL SEARCH REPORT

International application No.
PCT/US 03/12704

Box I Observations where certain claims were found unsearchable (Continuation of item 1 of first sheet)

This International Search Report has not been established in respect of certain claims under Article 17(2)(a) for the following reasons:

- 1. Claims Nos.:
because they relate to subject matter not required to be searched by this Authority, namely:

- 2. Claims Nos.: 8-48
because they relate to parts of the International Application that do not comply with the prescribed requirements to such an extent that no meaningful International Search can be carried out, specifically:
see FURTHER INFORMATION sheet PCT/ISA/210

- 3. Claims Nos.:
because they are dependent claims and are not drafted in accordance with the second and third sentences of Rule 6.4(a).

Box II Observations where unity of invention is lacking (Continuation of item 2 of first sheet)

This International Searching Authority found multiple inventions in this international application, as follows:

- 1. As all required additional search fees were timely paid by the applicant, this International Search Report covers all searchable claims.

- 2. As all searchable claims could be searched without effort justifying an additional fee, this Authority did not invite payment of any additional fee.

- 3. As only some of the required additional search fees were timely paid by the applicant, this International Search Report covers only those claims for which fees were paid, specifically claims Nos.:

- 4. No required additional search fees were timely paid by the applicant. Consequently, this International Search Report is restricted to the invention first mentioned in the claims; it is covered by claims Nos.:

Remark on Protest

- The additional search fees were accompanied by the applicant's protest.
- No protest accompanied the payment of additional search fees.

INTERNATIONAL SEARCH REPORT

Information on patent family members

International Application No

PCT/US 03/12704

Patent document cited in search report		Publication date	Patent family member(s)	Publication date
US 6171287	B1	09-01-2001	US 2002193752 A1	19-12-2002
			AU 748632 B2	06-06-2002
			AU 4217199 A	13-12-1999
			BR 9910754 A	03-07-2001
			CN 1309574 T	22-08-2001
			EP 1082159 A1	14-03-2001
			JP 2002516160 T	04-06-2002
			WO 9961093 A1	02-12-1999
US 6228060	B1	08-05-2001	AU 6023399 A	21-03-2000
			EP 1131129 A1	12-09-2001
			WO 0012171 A1	09-03-2000
			US 2001020153 A1	06-09-2001
WO 9961093	A	02-12-1999	AU 748632 B2	06-06-2002
			AU 4217199 A	13-12-1999
			BR 9910754 A	03-07-2001
			CN 1309574 T	22-08-2001
			EP 1082159 A1	14-03-2001
			JP 2002516160 T	04-06-2002
			WO 9961093 A1	02-12-1999
			US 2002193752 A1	19-12-2002
			US 6171287 B1	09-01-2001
			US 6344033	B1
AU 745426 B2	21-03-2002			
AU 4952299 A	06-12-1999			
BR 9906503 A	19-09-2000			
CN 1272064 T	01-11-2000			
EP 0998325 A2	10-05-2000			
JP 2002515311 T	28-05-2002			
WO 9959672 A2	25-11-1999			
US 5807348	A	15-09-1998	US 5814024 A	29-09-1998
			EP 0964710 A1	22-12-1999
			WO 9823313 A1	04-06-1998
WO 03049802	A	19-06-2003	US 2003109853 A1	12-06-2003
			WO 03049802 A1	19-06-2003