

Aug. 27, 1963

H. W. BATCHELLER

3,101,765

MACHINE FOR CRIMPING TERMINALS ON WIRES

Filed Aug. 9, 1956

3 Sheets-Sheet 1

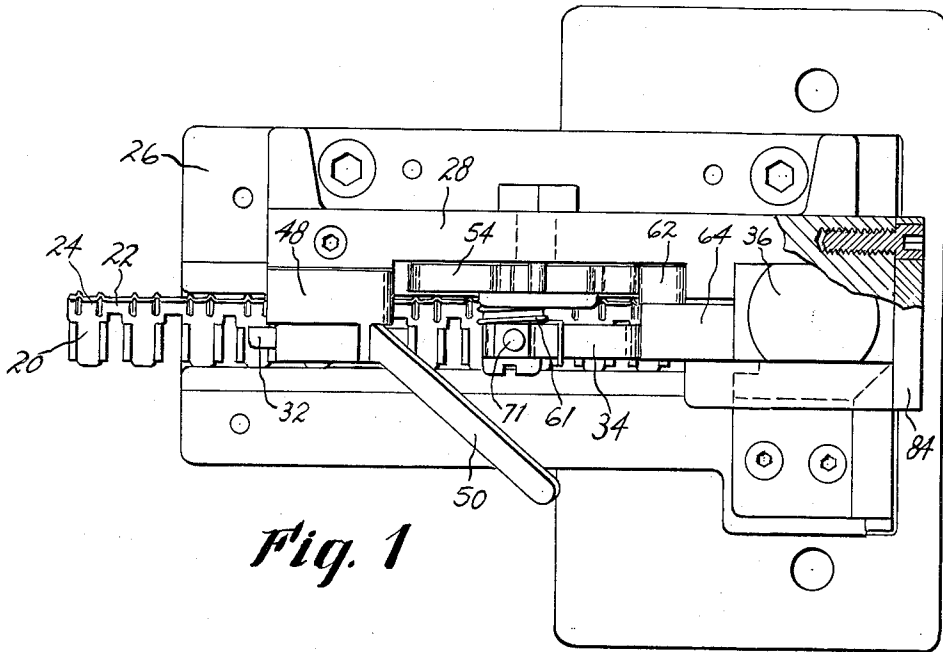

Fig. 1

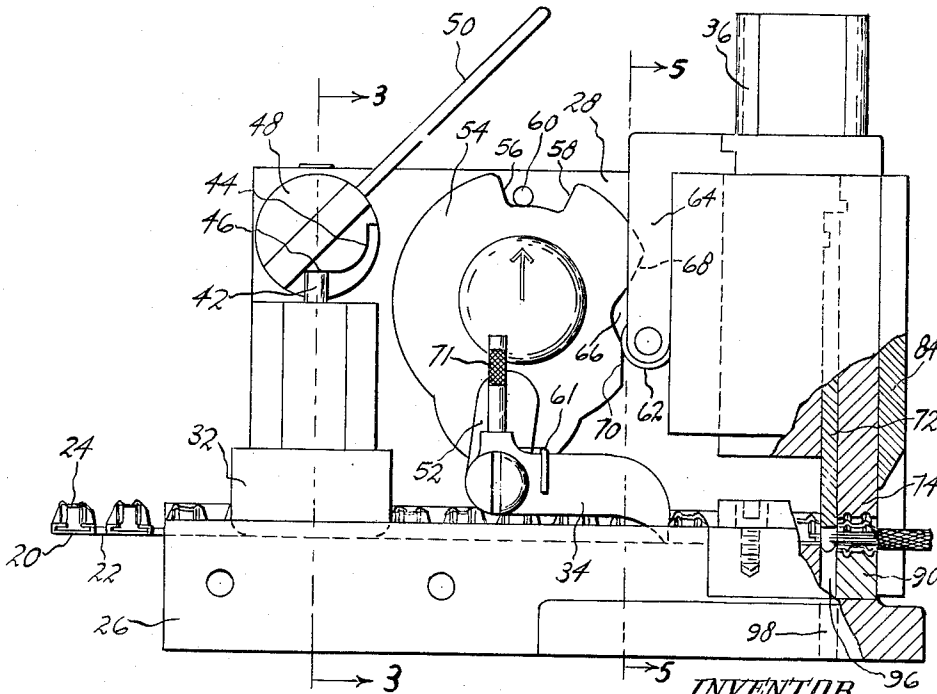

Fig. 2

INVENTOR
Hugh W. Batcheller
by Wright, Brown,
Quincy & May
ATT'YS

Aug. 27, 1963

H. W. BATCHELLER

3,101,765

MACHINE FOR CRIMPING TERMINALS ON WIRES

Filed Aug. 9, 1956

3 Sheets-Sheet 2

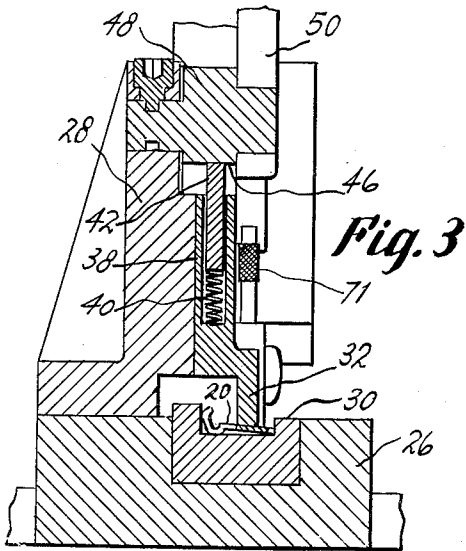

Fig. 3

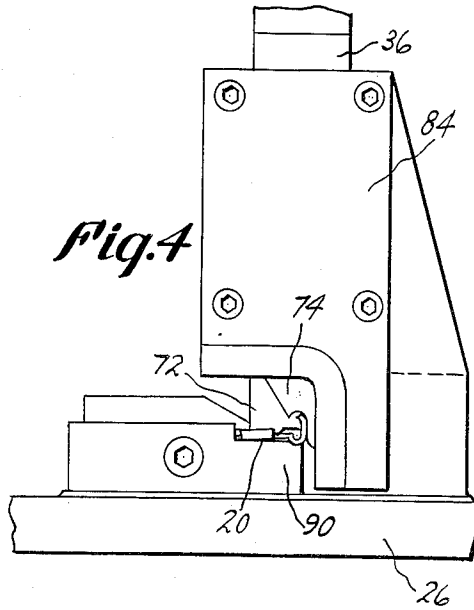

Fig. 4

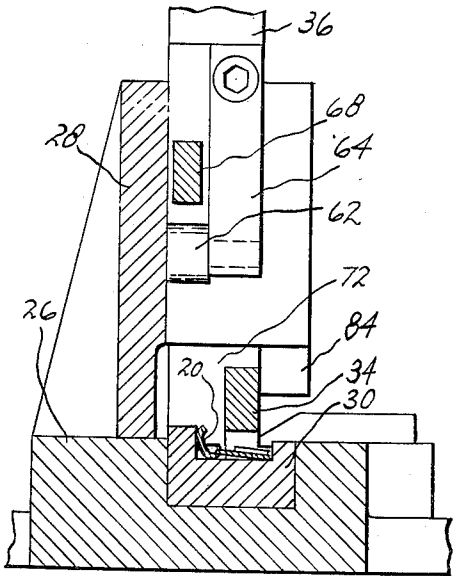

Fig. 5

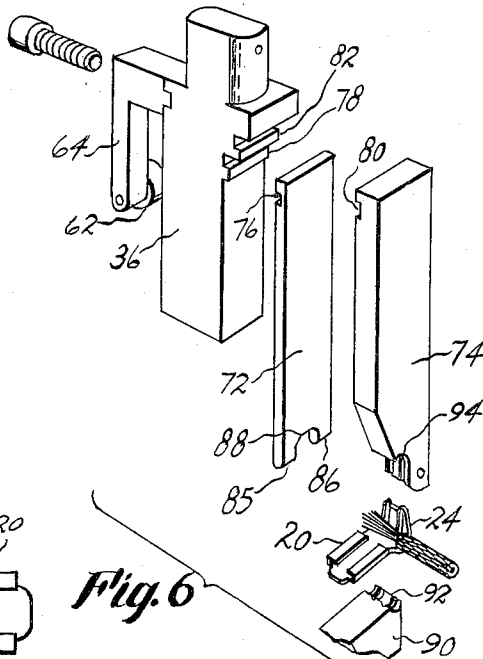

Fig. 6

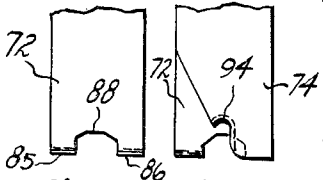

Fig. 7 Fig. 8

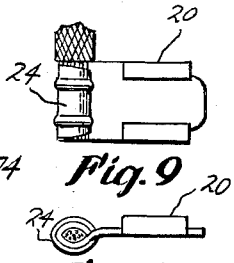

Fig. 9 Fig. 10

INVENTOR
 Hugh W. Batcheller
 by Wright, Brown,
 Quinby & May
 ATTYS

Aug. 27, 1963

H. W. BATCHELLER

3,101,765

MACHINE FOR CRIMPING TERMINALS ON WIRES

Filed Aug. 9, 1956

3 Sheets-Sheet 3

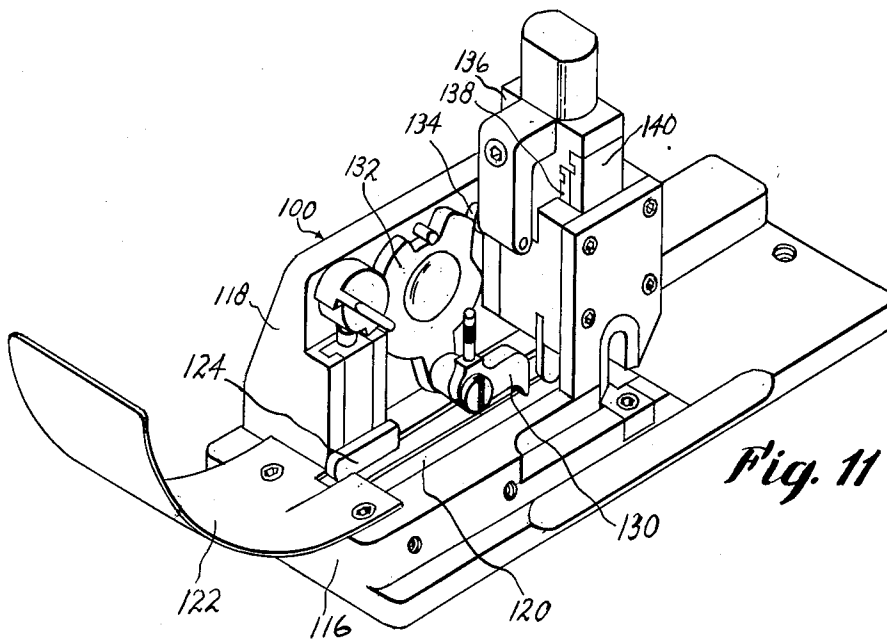

Fig. 11

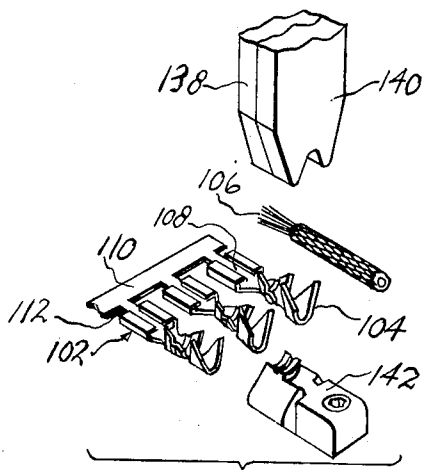

Fig. 12

INVENTOR
Hugh W. Batcheller
by Wright, Brown,
Quinby & May ATT'YS

1

2

3,101,765
**MACHINE FOR CRIMPING TERMINALS
 ON WIRES**

Hugh W. Batcheller, Newton Highlands, Mass., assignor
 to Kent Mfg. Corp., Newton, Mass., a corporation of
 Massachusetts

Filed Aug. 9, 1956, Ser. No. 603,067

2 Claims. (Cl. 153-1)

This invention relates to improvements in machines for crimping on wires electric terminals such, for example, as connector members. In wiring many kinds of electrical appliances, increasing use is being made of pre-cut lengths of insulated wire, usually stranded, to the stripped ends of which connector members are secured by various methods such as crimping, soldering or welding. The connectors are usually of a male-and-female variety, the complementary members of which can be quickly joined to make a firm electrical connection. For speed and convenience in preparing pre-cut lengths of wire for use, terminal elements such as connector members are formed from metal strip stock in a series the successive members of which are joined by narrow necks of metal to be severed as the members are secured to wires. Long series of such members in coils or rolls are supplied to machines which crimp the wire-gripping tongues of each member about a wire and sever the crimped connector member from the next succeeding member in the series. It is an object of the present invention to provide a crimping machine which is more reliable in operation than previous machines for the same purpose, which is easier to operate, which is more readily adjusted, and which is more economical to build. The features of construction which make possible these advantages are hereinafter described and are illustrated on the drawings, of which—

FIGURE 1 is a plan view of a machine embodying the invention;

FIGURE 2 is a side elevation of the same, a portion being broken away to show in section;

FIGURE 3 is a section on the line 3-3 of FIGURE 2;

FIGURE 4 is a front end elevation of the machine;

FIGURE 5 is a section on the line 5-5 of FIGURE 2;

FIGURE 6 is an exploded perspective view of the plunger and tools carried thereby;

FIGURE 7 is a fragmentary elevation of the knife shown in FIGURE 6;

FIGURE 8 is a fragmentary elevation of the knife and crimping tool;

FIGURE 9 is a plan view, on an enlarged scale, of a terminal crimped on a wire;

FIGURE 10 is a side elevation of the same;

FIGURE 11 is a perspective view of a crimping machine modified to operate on another form of terminal; and

FIGURE 12 is an exploded perspective view of the crimping tools of the machine shown in FIGURE 11, together with terminals of the kind operated upon by this machine.

The machine illustrated in FIGURE 1 is designed to operate on a series of connector members 20 of the type shown in that figure. These connector members are adapted to be attached to a wire extending transversely with respect to the axis of the connector member. Connector members of this description can be supplied in series of considerable length, the individual members being attached to one another in the series by bonds 22 between the wire-gripping portions 24 and successive members. The wire-gripping portion 24 of each member is shaped to receive a wire, being in the form of a trough one wall of which extends upward ready to be curled or crimped over a wire laid in the trough. A series of these members so connected is fed to a crimping machine which operates to cut off the bond joining the leading member

to the next in the series. At the same time the strands of a stranded wire which has been inserted in the machine are gathered, centered and straightened in the trough of the wire-gripping portion of the member and the projecting ends of the strands are trimmed off immediately before the upstanding portion of the member is curled or crimped over the wire to embrace and grip it.

The crimping machine illustrated in FIGURES 1 and 2 has a base 26 adapted to be secured on the table of a power press, and an upright frame 28 which may be integral with the base or firmly secured thereon. The upper face of the base 26 is channeled to receive a track 30 which is fixed in the channel and extends for the greater part of the length of the base. The connector members 20 are fed along the track to a crimping station. When the track becomes worn it can quickly be replaced with a new one. As indicated in FIGURES 3 and 5, the upper face of the track 30 is channeled to guide the line of connector members 20 therein.

The operating parts of the device comprise a friction drag shoe 32 bearing on the strip of connector members near the entering end of the device, a strip feeding pawl 34, and a plunger 36 which carries the tools for crimping and cutting off. The friction drag is spring pressed to bear on a portion of the strip of connector members to prevent any overrunning of the strip after a feeding movement. The pawl is reciprocated at the proper moments to feed the strip step by step a distance just sufficient to replace the connector member which has been crimped to a wire and discharged by moving up the next member in the strip so that such next member will be in correct position to receive and be crimped on a wire inserted for that purpose.

The friction drag 32 is vertically slidable against the frame 28. The upper extension 38 of the drag is provided with a bore in which is seated a spring 40. This spring is pressed downward by a stem 42 which in turn is pressed by cam surface 44, 46 on a rockable disc 48 mounted on the frame 28. The portion 44 of the cam edge of the disc is further from the rocking axis than is the portion 46. Hence, when the disc is in the angular position shown in FIGURE 2, the pressure on the spring 40 is relieved so there is little or no pressure on the drag shoe 32 and a strip of connector members can be easily moved in either direction in the guide channel of the track 30. When the disc 48 is rocked clockwise by means of a convenient handle or lever 50 to the angular position in which the portion 44 of the cam edge bears on the top of the stem 42, the stem compresses the spring 40 so that the drag shoe 32 presses strongly on the connector members beneath it, and a strong pull is required to move the strip of connector members in either direction on the track 30.

The feeding pawl 34 is pivotally attached to a short radial arm 52 projecting from a disc 54. This disc is rockably mounted on the frame 28, the extent of rocking movement being limited by the end walls 56, 58 of a notch in the periphery of the disc which engage a fixed pin 60 projecting from the frame 28 into the notch. As is evident from FIGURE 2, rocking movement of the disc 54 reciprocates the feeding pawl 34, the tip of which is pressed yieldingly downward by a spring 61 and engages a side wall of a connector member in the strip on the track 30. Each stroke of the pawl pushes the strip a distance exactly equal to the distance between centers of successive members therein, the distance of advance being determined by the arcuate length of the notch in the periphery of the disc 54 so that a quick operation of the disc cannot result in an overthrow. The disc is rocked in response to the reciprocation of the plunger 36 which carries a roller 62 on an arm 64 detachably secured thereto. The roller 62 rides in a recess 66 in

the periphery of the disc 54 and as it rises and falls with the movements of the plunger 36, it rocks the disc clockwise or counterclockwise according as it is descending or ascending. The wall of the recess 66 is preferably but not necessarily arcuate and is shaped so that the movements of the roller 62 rock the disc through the desired angle. The ends of the active portions of this wall merge into straight edge portions 68 and 70, these portions being arranged so that each is vertical when the roller 62 rides onto it from the active portion of the wall. As a result, the rocking movements of the disc 54 take place during the mid portion of each stroke of the plunger, the disc being held stationary during the terminal portions of each stroke of the plunger. As a result of this construction, small vertical adjustments of the plunger which are sometimes required to make the tools carried by the plunger crimp and cut off the connector members properly do not affect the operation of the feeding mechanism. Hence, when the feeding mechanism is correctly adjusted, such adjustment will not be disturbed by small adjustments of the stroke of the plunger. A handle 71 is provided to lift the pawl 34 clear when it is desired to introduce a strip of connector members into the machine or to remove it therefrom.

The plunger 36 carries two tools, namely, a knife or cutoff tool 72 and a crimping tool 74 (FIGURES 6-8). For convenience in manufacture and assembling, these tools are slabs of steel having the same width as that of the body of the plunger 36. The knife 72 fits against a face of the plunger 36 and has a tongue-and-groove engagement therewith. To this end a horizontal groove 76 near the upper end thereof fits on a horizontal rib 78 on the face of the plunger. The crimping tool 74 fits against the other broad face of the knife 72 and also has a tongue-and-groove engagement therewith, a horizontal groove 80 near the upper end thereof fitting on a higher rib 82 on the plunger. The body of the plunger and the two tools, when assembled, have a rectangular horizontal cross-section and fit closely but slidably in a vertical bore formed on three sides by portions of the frame 28 and the fourth side by a removable plate 84.

The lower end of the knife 72 is bifurcated as indicated in FIGURE 7. Between two prongs 85 and 86 the contour of the knife is upwardly arched as at 88 so that when the knife descends the upwardly converging portions of the arch will collect together the end portions of the strands of a stranded wire to which a connector member is to be attached. The mid portion of the arched edge 88 of the knife then severs the connecting bond 22 between the leading connector member 20 and the one next thereto, and also trims off the ends of the wire strands which project beyond the member 20. The crimping tool 74 which descends with the plunger 36 and knife 72 thereupon curls or crimps the upstanding wire-gripping portion 24 of the connector member around the end portion of the wire the strands of which have been gathered and trimmed. The result, illustrated in FIGURES 9 and 10, is a neat joint which is a more efficient current carrier than a welded joint of the same size. Supporting the connector member when it is crimped is an anvil 90 which is preferably detachable from the base for replacement when worn. The upper face of the anvil, on which the connector member rests has a trough 92 which receives the curved lower part of the wire-gripping portion 24 of the leading member 20 and cooperates with a recess 94 in the crimping tool 74 to curl or crimp the wire-gripping portion of the member 20 around the wire. Between the anvil 90 and the end of the track 30 is a clearance 96 wide enough to receive the lower end of the knife 72. This clearance is over a vertical passageway 98 through the base 26 so that when a connecting bond 22 is severed from the strip and ends are trimmed from the strands of a wire, the severed bits fall down through the passageway 98 into a suitable receptacle (not shown).

Machines can be constructed having most of the novel features of the machine hereinbefore described but modified to operate on series of other kinds of connector members. For example, FIGURES 11 and 12 show a machine 100 designed to operate on a series of connector members 102 having wire-gripping portions 104 arranged to receive a wire 106 laid therein in line with the longitudinal axis of the terminal portion 108 of the member 102. These members are joined by a narrow strip 110 to which each member 102 is connected by a bond 112 integral with the strip 110.

The machine 100 has a base 116 with an upstanding frame 118 thereon. A track 120 is removably mounted in the top of the base 116. The track receives a strip of connector members which are guided to the track by a guide 122. A frictional drag is impressed on the strip in the track by a shoe 124 which is pressed downward by means hereinbefore described. A feeding pawl 130 is actuated by a rockable disc 132 which is rocked by a roller 134 carried by a plunger 136 which is vertically reciprocable by power means (not shown). The plunger 136 also carries, as parts thereof, a cutoff tool (not shown) arranged to sever the leading connector member from the connecting strip 110 by cutting the connector bond 112, and crimping tools 138 and 140 arranged to curl or crimp the tongues of the wire-gripping portion 104 of the leading connector member which is supported on a suitable anvil 142. The operation of this machine is substantially the same as that of the machine shown in FIGURE 1, except that the wires are introduced from the side rather than the end of the machine.

I claim:

1. In a machine for crimping the wire-gripping portion of a connector member about a stranded wire which is transverse to the axis of the connector member, a vertically reciprocable plunger carrying crimping and cutting tools in mutual face-to-face contact for operating simultaneously on said wire-gripping portion of a connector member and the wire laid thereon, said cutting tool including means operating to gather and center the strands of said wire immediately before said wire-gripping portion is crimped.

2. In a machine for crimping the wire-gripping portion of a connector member about a wire which is transverse to the axis of the connector member, a vertically reciprocable plunger carrying crimping and cutting tools in mutual face-to-face contact, said cutting tool having its lower end shaped with upwardly converging edge portions to gather and center the strands of a stranded wire placed on the wire-gripping portion of a connector member in the machine as the tools descend to trim off the end of the wire and crimp the wire-gripping portion of the connector member around the portion of the wire next to the trimmed end thereof.

References Cited in the file of this patent

UNITED STATES PATENTS

1,278,138	Gibbs	Sept. 10, 1918
1,687,574	Liss	Oct. 16, 1928
1,719,561	Roth	July 2, 1929
1,764,638	McKeon	June 17, 1930
1,870,364	Jones	Aug. 9, 1932
2,264,520	Gleason	Dec. 2, 1941
2,494,137	Martines	Jan. 10, 1950
2,592,276	Hackbarth	Apr. 8, 1952
2,681,447	Davis	June 22, 1954
2,705,797	Handel	Apr. 12, 1955
2,839,824	Berg	June 24, 1958

FOREIGN PATENTS

1,048,060	France	July 29, 1953
1,112,139	France	Mar. 8, 1956