

A. L. WEEKES.
 FUSE SWITCH.
 APPLICATION FILED MAY 3, 1910.

998,435.

Patented July 18, 1911.

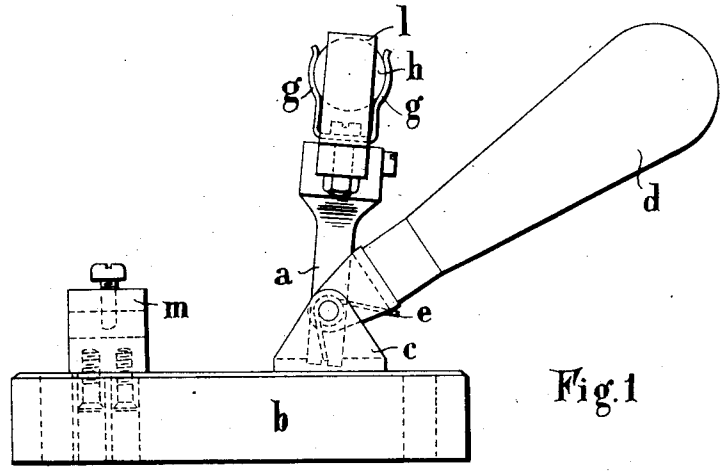

Fig. 1

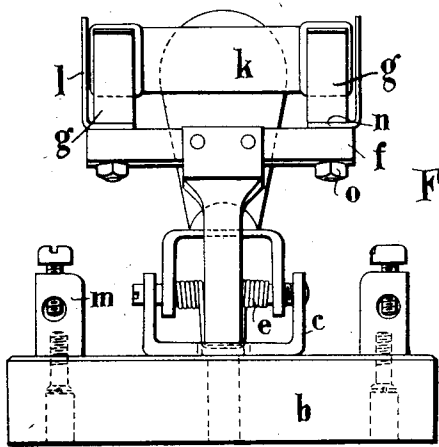

Fig. 2

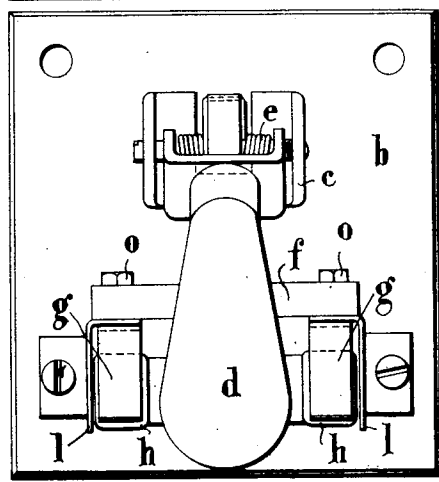

Fig. 3

WITNESSES
J. P. Davis
O. L. Rollhaus

INVENTOR
Atmos Lawrence Weekes
 BY *Munroe*
 ATTORNEYS

UNITED STATES PATENT OFFICE.

AMOS LAWRENCE WEEKES, OF HARPENDEN, ENGLAND.

FUSE-SWITCH.

998,435.

Specification of Letters Patent. Patented July 18, 1911.

Application filed May 3, 1910. Serial No. 559,175.

To all whom it may concern:

Be it known that I, AMOS LAWRENCE WEEKES, a subject of the King of Great Britain and Ireland, and residing at Harpenden, in the county of Herts, England, have invented certain new and useful Improvements in Fuse-Switches, of which the following is a specification.

This invention relates to fuse switches, that is, switches in which the current is caused to pass over fuses forming part thereof.

The object of the present invention is to obtain a compact form of fuse switch and to render the parts simple, easy to replace and thoroughly efficient in action.

In the accompanying drawings:—Figures 1, 2 and 3 are two elevations and a plan respectively illustrating one form of switch constructed in accordance with the present invention.

In carrying out the invention according to one mode a switch arm, *a*, of approximately T shape is pivoted to the base, *b*, by any convenient form of saddle or bracket, *c*, which may also carry the operating handle, *d*, and spring, *e*, for giving a quick action. The cross bar, *f*, of the switch arm is formed of insulating material and carries at its ends spring clips, *g*, adapted in known manner to embrace the ends, *h*, of the fuse, *k*, so as to hold the same securely but to allow of its ready insertion or removal by simply springing it into or out of engagement therewith. The fuse, *k*, is preferably made in cylindrical form with metallic collars, *h*, for engaging the clips, *g*. At the extreme ends of the cross bar *f*, and at right angles thereto other spring members *l*, are provided and these members are adapted to engage the main contacts, *m*, which may be of solid form as shown. The fuse, *k*, lies between the spring members, *l*, which form the switch blades, and the latter are preferably secured to the switch arm by flanges, *n*, secured by screws, *o*, which may also secure the spring clips, *g*, in position. The spring members, *l*, may be formed upon the collars, *h*, of the fuse member, but it is preferred to mount the spring members, *l*, upon the cross bar, *f*, of the switch arm as illustrated. By this means the current is passed by way of one contact, spring switch blade, spring clip and fuse to the other spring clip, switch blade and contact.

One feature of importance in a fuse

switch constructed in accordance with this invention lies in the arrangement of the fuse member at right angles to the switch arm so that the two ends of the fuse and the switch blades move simultaneously away from the main contacts and in a parallel manner. Further, the said blades formed as spring members enable solid main contacts to be used.

Having now described my invention what I claim as new and desire to secure by Letters Patent is:—

1. A fuse switch comprising a single switch arm, a bar arranged at right angles to said arm, means for attaching the fuse member to said bar, means for insulating said fuse member from said arm, and means for completing the circuit through said fuse member.

2. A fuse switch comprising a single switch arm, a bar of insulating material attached to said arm at right angles thereto, a fuse member attached to said bar, a base on which said arm is pivoted, and means for completing the circuit through said fuse member.

3. A fuse switch comprising a single switch arm, a bar of insulating material attached to said arm at right angles thereto, a fuse member attached to said bar, a pair of spring clips on said bar to hold the fuse member in position thereon, a base on which said arm is pivoted, and means for completing the circuit through said fuse member.

4. A fuse switch comprising a single switch arm, a bar of insulating material attached to said arm at right angles thereto, a pair of spring clips on said bar to hold the fuse member in position thereon, a base on which said arm is pivoted, a pair of contacts on said base, and means for connecting the ends of the fuse member with said contacts.

5. A fuse switch comprising a single switch arm, a bar of insulating material attached to said arm at right angles thereto, a pair of spring clips attached to the ends of said bar to hold the fuse member in position thereon, a base on which the switch arm is pivoted, a pair of contacts on said base, and a pair of spring members on the ends of the insulating bar adapted to make contact between said contacts and the ends of the fuse member when the switch is in its closed position.

6. A fuse switch comprising a single
switch arm, a bar of insulating material at-
tached to said arm at right angles thereto, a
pair of spring clips attached to the ends of
5 said bar to hold the fuse member in posi-
tion thereon, a base on which the switch arm
is pivoted, a pair of contacts on said base, a
pair of spring members on the ends of the
insulating bar adapted to make contact be-
10 tween said contacts and the ends of the fuse

member when the switch is in its closed posi-
tion, an operating handle pivoted on the
pin supporting the switch arm, and a spring
adapted to give a quick break to the switch.

In testimony whereof I affix my signature 15
in the presence of two witnesses.

AMOS LAWRENCE WEEKES.

Witnesses:

N. WARREN TRIGGS,

BERTRAM H. MATTHEWS.

Copies of this patent may be obtained for five cents each, by addressing the "Commissioner of Patents,
Washington, D. C."
