

(19) World Intellectual Property Organization
International Bureau



(43) International Publication Date
5 January 2006 (05.01.2006)

PCT

(10) International Publication Number
WO 2006/001797 A1

(51) International Patent Classification⁷: A61B 17/14

(21) International Application Number:
PCT/US2004/018705

(22) International Filing Date: 14 June 2004 (14.06.2004)

(25) Filing Language: English

(26) Publication Language: English

(71) Applicant (for all designated States except US): PE-
LIKAN TECHNOLOGIES, INC. [US/US]; 1072 East
Meadow Circle, Palo Alto, CA 94303 (US).

(72) Inventors; and

(75) Inventors/Applicants (for US only): FREEMAN, Do-
minique, M. [GB/US]; 4545 La Honda Road, La Honda,
CA 94020 (US). ALDEN, Don [US/US]; 1312 Nelson
Way, Sunnyvale, CA 94087 (US). WITTIG, Michael
[US/US]; 1072 East Meadow Circle, Palo Alto, CA 94303
(US). BOECKER, Dirk [DE/US]; 1652 Castilleja, Palo
Alto, CA 94306 (US).

(74) Agent: TUNG, Hao, Y.; Heller Ehrman White &
McAuliffe LLP, 275 Middlefield Road, Menlo Park, CA
94025-3506 (US).

(81) Designated States (unless otherwise indicated, for every
kind of national protection available): AE, AG, AL, AM,
AT, AU, AZ, BA, BB, BG, BR, BW, BY, BZ, CA, CH, CN,
CO, CR, CU, CZ, DE, DK, DM, DZ, EC, EE, EG, ES, FI,
GB, GD, GE, GH, GM, HR, HU, ID, IL, IN, IS, JP, KE,
KG, KP, KR, KZ, LC, LK, LR, LS, LT, LU, LV, MA, MD,
MG, MK, MN, MW, MX, MZ, NA, NI, NO, NZ, OM, PG,
PH, PL, PT, RO, RU, SC, SD, SE, SG, SK, SL, SY, TJ, TM,
TN, TR, TT, TZ, UA, UG, US, UZ, VC, VN, YU, ZA, ZM,
ZW.

(84) Designated States (unless otherwise indicated, for every
kind of regional protection available): ARIPO (BW, GH,
GM, KE, LS, MW, MZ, NA, SD, SL, SZ, TZ, UG, ZM,
ZW), Eurasian (AM, AZ, BY, KG, KZ, MD, RU, TJ, TM),
European (AT, BE, BG, CH, CY, CZ, DE, DK, EE, ES, FI,
FR, GB, GR, HU, IE, IT, LU, MC, NL, PL, PT, RO, SE,
SI, SK, TR), OAPI (BF, BJ, CF, CG, CI, CM, GA, GN,
GQ, GW, ML, MR, NE, SN, TD, TG).

Published:

— with international search report

For two-letter codes and other abbreviations, refer to the "Guid-
ance Notes on Codes and Abbreviations" appearing at the begin-
ning of each regular issue of the PCT Gazette.



WO 2006/001797 A1

(54) Title: LOW PAIN PENETRATING

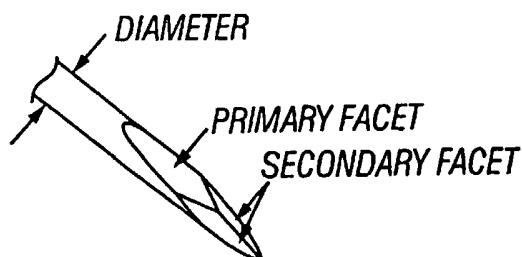

(57) Abstract: Reducing the volume or
drag on skin of the penetrating member
(183) entering the wound during the cutting
process will reduce the pain associated with
lancing and result in less power desired for
retraction of the penetrating member from
the skin (233). A variety of other penetrating
member configuration is shown in the
application.

LOW PAIN PENETRATING MEMBER

BACKGROUND OF THE INVENTION

Lancing devices are known in the medical health-care products industry for piercing the skin to produce blood for analysis. Typically, a drop of blood for this type of analysis is obtained by making a small incision in the fingertip, creating a small wound, which generates a small blood droplet on the surface of the skin.

Early methods of lancing included piercing or slicing the skin with a needle or razor. Current methods utilize lancing devices that contain a multitude of spring, cam and mass actuators to drive the lancet. These include cantilever springs, diaphragms, coil springs, as well as gravity plumbs used to drive the lancet. The device may be held against the skin and mechanically triggered to ballistically launch the lancet.

Unfortunately, the pain associated with each lancing event using known technology discourages patients from testing. In addition to vibratory stimulation of the skin as the driver impacts the end of a launcher stop, known spring based devices have the possibility of firing lancets that harmonically oscillate against the patient tissue, causing multiple strikes due to recoil. This recoil and multiple strikes of the lancet is one major impediment to patient compliance with a structured glucose monitoring regime. Known lancets also have a configuration which may contribute in part to the pain associated with lancing for body fluid generation.

Additionally, known lancets have geometries that may contribute to the pain associated with lancing. Most known lancets fail to balance between reducing pain but creating a wound generating sufficient blood or other body fluid flow. Accordingly, there is a need for improved penetrating members for addressing these deficiencies.

SUMMARY OF THE INVENTION

The present invention provides solutions for at least some of the drawbacks discussed above. Specifically, some embodiments of the present invention provide an improved penetrating member configuration for penetration into tissue. Some embodiments of these penetrating members may be used with intelligent control of the

velocity profile that will increase the likelihood of spontaneous blood generation. At least some of these and other objectives described herein will be met by embodiments of the present invention.

In one aspect of the present invention, the invention relates to minimizing the pain of skin lancing based on reducing the volume of penetrating member material interacting with the skin during the cutting process. This may be achieved through surface modification or geometry changes such that cutting efficiency is increased.

Reducing the volume or drag on skin or sharpness of the penetrating member entering the wound during the cutting process will reduce the pain associated with lancing, and result in less power desired for retraction of the penetrating member from the skin.

A further understanding of the nature and advantages of the invention will become apparent by reference to the remaining portions of the specification and drawings.

The system may further comprise means for coupling the force generator with one of the penetrating members.

The system may further comprise a penetrating member sensor positioned to monitor a penetrating member coupled to the force generator, the penetrating member sensor configured to provide information relative to a depth of penetration of a penetrating member through a skin surface.

The depth of penetration may be about 100 to 2500 microns.

The depth of penetration may be about 500 to 750 microns.

The depth of penetration may be, in this nonlimiting example, no more than about 1000 microns beyond a stratum corneum thickness of a skin surface.

The depth of penetration may be no more than about 500 microns beyond a stratum corneum thickness of a skin surface.

The depth of penetration may be no more than about 300 microns beyond a stratum corneum thickness of a skin surface.

The depth of penetration may be less than a sum of a stratum corneum thickness of a skin surface and 400 microns.

The penetrating member sensor may be further configured to control velocity of a penetrating member.

The active penetrating member may move along a substantially linear path into the tissue.

The active penetrating member may move along an at least partially curved path into the tissue.

The driver may be a voice coil drive force generator.

The driver may be a rotary voice coil drive force generator.

The penetrating member sensor may be coupled to a processor with control instructions for the penetrating member driver.

The processor may include a memory for storage and retrieval of a set of penetrating member profiles utilized with the penetrating member driver.

The processor may be utilized to monitor position and speed of a penetrating member as the penetrating member moves in a first direction.

The processor may be utilized to adjust an application of force to a penetrating member to achieve a desired speed of the penetrating member.

The processor may be utilized to adjust an application of force to a penetrating member when the penetrating member contacts a target tissue so that the penetrating member penetrates the target tissue within a desired range of speed.

The processor may be utilized to monitor position and speed of a penetrating member as the penetrating member moves in the first direction toward a target tissue, wherein the application of a launching force to the penetrating member is controlled based on position and speed of the penetrating member.

The processor may be utilized to control a withdraw force to the penetrating member so that the penetrating member moves in a second direction away from the target tissue.

In the first direction, the penetrating member may move toward the target tissue at a speed that is different than a speed at which the penetrating member moves away from the target tissue.

In the first direction the penetrating member may move toward the target tissue at a speed that is greater than a speed at which the penetrating member moves away from the target tissue.

The speed of a penetrating member in the first direction may be the range of about 2.0 to 10.0 m/sec.

The average velocity of the penetrating member during a tissue penetration stroke in the first direction may be about 100 to about 1000 times greater than the average velocity of the penetrating member during a withdrawal stroke in a second direction.

A further understanding of the nature and advantages of the invention will become apparent by reference to the remaining portions of the specification and drawings.

BRIEF DESCRIPTION OF THE DRAWINGS

Figure 1 is a side view of one embodiment of the invention, which includes dimples impressed across the contact area of the penetrating member.

Figure 2 is a detail side view of the tip of the penetrating member.

Figure 3 is a side view of one embodiment of the invention, which includes a splined cross-section.

Figure 4 is a detail side view of the tip of the penetrating member shown in Figure 3.

Figure 5 is a cross-sectional view of the shaft of the penetrating member shown in Figure 3.

Figure 6 is a side view of a standard lancet design.

Figure 7 is a detail side view of a standard lancet design.

Figure 8 is a front view of the lancet design of Figure 6.

Figure 9 is a sectional side view of the lancet design of Figure 8.

Figure 10 is a detail side view of the lancet design of Figure 9, showing the addition of a layer of coating to the lancet.

Figure 11 is a side view of one embodiment of the invention, which includes a cross-section with cutouts on the bottom portion of the penetrating member to reduce the area in contact with the penetrated matter.

Figure 12 is a detail side view of the penetrating member of Figure 11.

Figure 13 is a cross-sectional view of section D-D of the penetrating member of Figure 11.

Figure 14 is a cross-sectional view of section C-C of the penetrating member of Figure 11.

Figure 15 is a side view of one embodiment of the invention which includes a cross-section ground on either side of the bottom portion of the penetrating member to reduce the area in contact with the penetrated matter.

Figure 16 is a detail side view of the penetrating member of Figure 15.

Figure 17 is a cross-sectional view of section D-D of the penetrating member of Figure 15.

Figure 18 is a cross-sectional view of section C-C of the penetrating member of Figure 15.

Figure 19 shows a further embodiment of Figure 15 for reducing the volume of metal inside skin during the lancing event.

Figure 20 shows yet another embodiment of the present invention.

Figure 21 shows the general elements of a penetrating member tip.

Figure 22 shows various embodiments of a penetrating member tip.

Figures 23 shows the portions and measurements of one embodiment of the present invention.

Figures 24-29 are perspective views of various embodiments of the present invention.

Figure 30 is a table showing specific measurements of various penetrating members.

Figure 31 illustrates an embodiment of a controllable force driver in the form of a cylindrical electric penetrating member driver using a coiled solenoid -type configuration.

Figure 32A illustrates a displacement over time profile of a penetrating member driven by a harmonic spring/mass system.

Figure 32B illustrates the velocity over time profile of a penetrating member driver by a harmonic spring/mass system.

Figure 32C illustrates a displacement over time profile of an embodiment of a controllable force driver.

Figure 32D illustrates a velocity over time profile of an embodiment of a controllable force driver.

Figure 33 is a diagrammatic view illustrating a controlled feed-back loop.

Figure 34 is a perspective view of a tissue penetration device having features of the invention.

Figure 35 is an elevation view in partial longitudinal section of the tissue penetration device of Figure 4.

Figures 36A-36G shows a method of penetrating tissue.

Figure 37 shows one embodiment of disc for use with the present invention.

Figure 38 shows one view of the disc in a penetrating member device.

Figure 39 shows another embodiment of a device that may use a disc as described in Figure 37.

DESCRIPTION OF THE SPECIFIC EMBODIMENTS

The present invention provides a solution for body fluid sampling. Specifically, some embodiments of the present invention provides a method for improving spontaneous blood generation. The invention may be designed for use with a high density penetrating member cartridge. It may use penetrating members of smaller size, such as but not limited to diameter or length, than those of lancets known in the art. The cutting surfaces of the penetrating member may be configured for improved cutting. At least some of these and other objectives described herein will be met by embodiments of the present invention.

It is to be understood that both the foregoing general description and the following detailed description are exemplary and explanatory only and are not restrictive of the invention, as claimed. It may be noted that, as used in the specification and the appended claims, the singular forms "a", "an" and "the" include plural referents unless the context clearly dictates otherwise. Thus, for example, reference to "a material" may include mixtures of materials, reference to "a chamber" may include multiple chambers, and the like. References cited herein are hereby incorporated by reference in their entirety, except to the extent that they conflict with teachings explicitly set forth in this specification.

In this specification and in the claims which follow, reference will be made to a number of terms which shall be defined to have the following meanings:

"Optional" or "optionally" means that the subsequently described circumstance may or may not occur, so that the description includes instances where the circumstance occurs and instances where it does not. For example, if a device optionally contains a feature for analyzing a blood sample, this means that the analysis feature may or may not

be present, and, thus, the description includes structures wherein a device possesses the analysis feature and structures wherein the analysis feature is not present.

Figure 1 is a side view of one embodiment of the invention, which includes dimples impressed across the contact area of the penetrating member.

Figure 2 is a detail side view of the tip of the penetrating member shown in Figure 1.

Figure 3 is a side view of one embodiment of the invention, which includes a splined cross-section.

Figure 4 is a detail side view of the tip of the penetrating member shown in Figure 3.

Figure 5 is a cross-sectional view of the shaft of the penetrating member shown in Figure 3.

Figure 6 is a side view of a standard lancet design.

Figure 7 is a detail side view of a standard lancet design.

Figure 8 is a front view of the lancet design of Figure 6.

Figure 9 is a sectional side view of the lancet design of Figure 8.

Figure 10 is a detail side view of the lancet design of Figure 9, showing the addition of a layer of coating to the lancet.

Figure 11 is a side view of one embodiment of the invention, which includes a cross-section with cutouts on the bottom portion of the penetrating member to reduce the area in contact with the penetrated matter.

Figure 12 is a detail side view of the penetrating member of Figure 11.

Figure 13 is a cross-sectional view of section D-D of the penetrating member of Figure 11.

Figure 14 is a cross-sectional view of section C-C of the penetrating member of Figure 11.

Figure 15 is a side view of one embodiment of the invention which includes a cross-section ground on either side of the bottom portion of the penetrating member to reduce the area in contact with the penetrated matter.

Figure 16 is a detail side view of the penetrating member of Figure 15.

Figure 17 is a cross-sectional view of section D-D of the penetrating member of Figure 15.

Figure 18 is a cross-sectional view of section C-C of the penetrating member of Figure 15.

Figure 19 A further embodiment of Figure 15 for reducing the volume of metal inside skin during the lancing event. Shaving the material from the "back" of the penetrating member while maintaining the cutting geometry and relationship of the angles of the secondary facets.

Figure 20 Reducing the volume of metal entering the skin during the lancing event by shaving material off the back and sides of the penetrating member while maintaining the geometry of the cutting tip (similar to Figures 15 and 19 but easier to grind for manufacturing purposes).

Figures 1, 3, 12, and 15 show embodiments that provide geometries designed to reduce the area of contact of the penetrating member with the penetrated material. As a nonlimiting example, Figures 1, 3, and 12 show embodiments that rely on the skin's inability to conform to concave surfaces when stretched. Figure 15 shows an embodiment, which simply reduces the surface area of the penetrating member: the shortest distance between two points, a line, is constructed in place of curved section. The apex of the lower portion of the penetrating member remains intact to provide a high section moment of inertia to the penetrating member, thereby maintaining penetrating member stiffness and tip stability. Maintaining penetrating member stiffness is important for minimizing lateral deflection of the tip, which is a primary contributor to lancing pain.

The embodiment of the invention shown in Figure 10 includes a penetrating member coated with polytetrafluoroethylene. The polytetrafluoroethylene coating serves to reduce the frictional force desired to drive the penetrating member during entry. Although polytetrafluoroethylene does not noticeably improve the performance of very high speed projectiles, such as those designed to penetrate armor, it is believed effective at reducing friction on projectiles on low speeds. The polytetrafluoroethylene coating also isolates the penetrated matter from the material of the penetrating member. This is advantageous for avoiding a possible contact allergic reaction to the material of the penetrating member. For example, 303 stainless steel contains 9% nickel by weight, and may induce a nickel allergy in a human coming into contact with it. This type of allergy can also appear after repeated contact with such a material, and once it appears it is

normally a chronic, lifelong condition. Polytetrafluoroethylene, however, is one of the most non-reactive materials known, and does not appear to cause such a condition.

In order to understand the factors controlling skin lancing, a detailed understanding of the cutting efficiency and profile of the penetrating member is desired. Creation of the wound channel and geometry of the cut are factors controlling blood yield and wound healing. Substantial effort has been put into understanding the penetrating member geometry and dimensions with relation to pain and blood yield.

Figure 21 shows a penetrating member geometry. A variety of controllable factors are known to result in painless, efficient blood droplet yield from the skin surface. These factors include the depth of penetrating member penetration to the vascular plexus; the manner in which the skin is stabilized prior to penetrating member impact and the geometry of the lancing device. Blood volume, success rate, pain, and wound formation may be related to the diameter, depth and facet geometry of the penetrating member tip. The preferred geometry for cutting is a three-facet design shown and this geometry is common in the industry. Manufacture of these types of penetrating members is generally by taking a rod of a given diameter (usually 250 –760 mm diameter) and grinding 8 degrees to the plane of the primary axis to create the primary facet. The secondary facets are then created by rotating the shaft of the penetrating member 15 degrees, and then rolling over 12 degrees to the plane of the primary facet. Other possible geometries desire altering the penetrating member's production parameters such as shaft diameter, angles, and translation distance. The features of the penetrating member tip affect lancing pain, cutting efficiency, wound healing and blood volume. Cutting efficiency is governed by the angle of the secondary facets.

Referring now to Figures 22 and 23, the facets lengths, angles and diameter of common industry standard penetrating members have been measured and are shown. Lancing pain and blood yield are integrally related to these mechanical parameters. A common precept is that the smaller the diameter of the penetrating member, the less lancing pain is perceived. For a given amount of blood however, the thin penetrating member must then go deeper to cut more vessels to get the same amount of blood (this is discussed in detail in the anatomy section). Consequently, a larger diameter penetrating member with a shallow penetration will cut the desired amount of blood vessels (capillaries) with less pain. Reducing the volume of metal entering the finger, which is not associated with the cutting diameter, may help reduce pain and reduce the amount of "drag" or force desired to remove the penetrating member from the finger. The ideas

presented Figures 1 – 20 are various embodiments directed at reducing the volume or friction of the penetrating member shaft in the skin.

Figure 22 shows facet geometry of penetrating members commonly used for glucose spot monitoring.

Figure 23A shows a drawing of relationship of facets and angles. In one embodiment as shown more clearly in Figure 23B, the facet B has a length of about 0.84 mm and the bevel joint length C is about 0.47mm.

In order to understand the factors controlling skin lancing, a detailed understanding of the cutting efficiency and profile of the lancet is desired. Creation of the wound channel and geometry of the cut are factors controlling blood yield and wound healing. Substantial effort has been put into understanding the lancet geometry and dimensions with relation to pain and blood yield.

A variety of controllable factors are known to result in painless, efficient blood droplet yield from the skin surface. These factors include the depth of lancet penetration to the vascular plexus; the manner in which the skin is stabilized prior to lancet impact and the geometry of the lancing device. Blood volume, success rate, pain, and wound formation may be related to the diameter, depth and facet geometry of the lancet tip.

The preferred geometry for cutting is a three-facet design shown and this geometry is common in the industry. Manufacture of these types of lancets is generally by taking a rod of a given diameter (usually 250 –760 mm diameter) and grinding 8 degrees to the plane of the primary axis to create the primary facet. The secondary facets are then created by rotating the shaft of the lancet 15 degrees, and then rolling over 12 degrees to the plane of the primary facet. Other possible geometries require altering the lancet's production parameters such as shaft diameter, angles, and translation distance. The features of the lancet tip affect lancing pain, cutting efficiency, wound healing and blood volume. The wound geometry from this style of lancet is shown on page 38.

Proprietary to PTI is the relationship of the facet lengths and angles, and the fact that there is no molded chuck on the shaft of the lancet. These "bare" lancets are not found in the industry today. The advantage of the PTI proprietary lancet is that wound healing is quicker and more efficient due to the optimized geometry. All lancets used in patient testing are quantified and checked for precision manufacturing and the presence of burrs or spurs, which affect performance and pain of lancing. All lancet specifications are

entered in the PTI database. For reference, A is the primary facet length (currently not measured, but calculated in the measurement process), B is the side facet length and C is the bevel joint length. The angles are derived as shown in the engineering drawing below.

Cutting efficiency is governed by the angle of the secondary facets. The importance of the lancet tip geometry and length of C is reflected in the complex relationship during cutting of the stratum corneum. Measurement of a simple inflection point in power or velocity on traversing the stratum corneum for determination of stratum corneum thickness is not possible since the situation is complicated by the entry of the lancet tip with respect to the distance along the C, B and A lengths.

The facets lengths, angles and diameter of common industry standard lancets have been measured and are shown in the Table below. As discussed above, lancing pain and blood yield are integrally related to these mechanical parameters. A common precept is that the smaller the diameter of the lancet, the less lancing pain is perceived. For a given amount of blood however, the thin lancet must then go deeper to cut more vessels to get the same amount of blood (this is discussed in detail in the anatomy section). Consequently, a larger diameter lancet with a shallow penetration will cut the desired amount of blood vessels (capillaries) with less pain. This is confirmed in histological cross sections of glabrous skin at the level of the papillary dermis and deeper, by measuring the distribution of blood vessels versus nerve branches cut for a given lancet footprint.

Pelikan lancet

In one embodiment, decreasing shaft diameter affects primarily the value of A, and somewhat the value of B. PTI laboratory experiments and histological sections have confirmed that a shallow penetration with a wide lancet (efficient cut) translates to low pain. In one embodiment, the B manufactured lancet of 313 mm is the lancet used in patient testing. The choice was primarily based on the fact that the B lancet can penetrate shallow depths (~ 600 to 800 mm) to get 1 microL of blood, whereas the Hart and BD II were unable to perform at shallower depths (0.5 – 1.0 mm) due to poor cutting efficiency. Shallow depth settings resulted in these lancets bouncing out of the skin, presumably due to the angle of the secondary facets and the long bevel joint length.

The recently released BD UF III is a 200 mm diameter lancet of different angle and facet length geometry than the BD UF II. This is due to the fact that the grinding

process described above results in modified angle relationships due to the reduced diameter of the shaft. To illustrate this a theoretical experiment would be to keep the B angle ratios constant and grind these on 200 mm bar stock to form the B III. There is a large effect on the facet lengths if the cutting angles are kept constant. The expectation is a quite different performance than the BD UF III, presumably again outperforming the BD UF III on small penetration depths. Similarly, the same thought experiment can be carried out if 200 mm bar stock is ground keeping the ABC lengths the same as the BD UF III, using the B grind protocol, the resulting angles are significantly different from the BD UF III. For comparison, the B II small diameter lancet has completely different angle and length perspective than other B produced lancets or industry standard offerings. Knowledge of tip geometry and facet lengths has a direct implication on the cutting efficiency and therefore performance of the lancet. It may very well be that there is an optimal lancet diameter and geometry for a given penetration depth and/or skin type.

Figure 24 shows an embodiment with 1 ½ bar. A three-facet penetrating member design ground from half-round bar stock. The primary angle is represented in pink, the secondary angles in blue and as indicated by the arrows. The volume is reduced by virtue of the fact that the bar stock is not fully round.

Figure 25 shows a three-facet penetrating member design ground from oval bar stock. The primary angle is represented in pink, the secondary angles in blue. Volume reduced by using oval stock rather than round.

Figure 26 shows a sewing needle – volume reduced by removing material behind the primary facet to beyond the maximum point of penetration.

Figure 27 shows a three spoon – volume reduction by shaving beyond the facets.

Figure 28 shows a C shape or half hypodermic patent needle. Volume reduction is achieved by removing all material except that needed for cutting and stability.

Figure 29 shows a ‘smashed end’ embodiment, easy to manufacture, reduced volume.

Figure 30 shows a table of some different dimensions, including those of various embodiments of the present invention.

It should be understood that any of the above penetrating members may be adapted for use with a penetrating member driver as described in Attorney Docket No. 38187-2551 and Attorney Docket No. 38187-2606. It should also be understood that these devices may also be used as bare penetrating member without an additional molded part coupled to the penetrating member. Other embodiments may, however, be designed for use with a molded or other attachment coupled to the penetrating member to facilitate handling.

While the invention has been described and illustrated with reference to certain particular embodiments thereof, those skilled in the art will appreciate that various adaptations, changes, modifications, substitutions, deletions, or additions of procedures and protocols may be made without departing from the spirit and scope of the invention. For example, with any of the above embodiments, the location of the penetrating member drive device may be varied, relative to the penetrating members or the cartridge. With any of the above embodiments, the penetrating member tips may be uncovered during actuation (i.e. penetrating members do not pierce the penetrating member enclosure or protective foil during launch). With any of the above embodiments, the penetrating members may be a bare penetrating member during launch. With any of the above embodiments, the penetrating members may be bare penetrating members prior to launch as this may allow for significantly tighter densities of penetrating members. In some embodiments, the penetrating members may be bent, curved, textured, shaped, or otherwise treated at a proximal end or area to facilitate handling by an actuator. The penetrating member may be configured to have a notch or groove to facilitate coupling to a gripper. The notch or groove may be formed along an elongate portion of the penetrating member. With any of the above embodiments, the cavity may be on the bottom or the top of the cartridge, with the gripper on the other side. In some embodiments, analyte detecting members may be printed on the top, bottom, or side of the cavities. The front end of the cartridge maybe in contact with a user during lancing. The same driver may be used for advancing and retraction of the penetrating member. The penetrating member may have a diameters and length suitable for obtaining the blood volumes described herein. The penetrating member driver may also be in substantially the same plane as the cartridge. The driver may use a through hole or other opening to

engage a proximal end of a penetrating member to actuate the penetrating member along a path into and out of the tissue.

The present invention may be used with a variety of different penetrating member drivers. It is contemplated that these penetrating member drivers may be spring based, solenoid based, magnetic driver based, nanomuscle based, or based on any other mechanism useful in moving a penetrating member along a path into tissue. It should be noted that the present invention is not limited by the type of driver used with the penetrating member feed mechanism. One suitable penetrating member driver for use with the present invention is shown in Figure 1. This is an embodiment of a solenoid type electromagnetic driver that is capable of driving an iron core or slug mounted to the penetrating member assembly using a direct current (DC) power supply. The electromagnetic driver includes a driver coil pack that is divided into three separate coils along the path of the penetrating member, two end coils and a middle coil. Direct current is alternated to the coils to advance and retract the penetrating member. Although the driver coil pack is shown with three coils, any suitable number of coils may be used, for example, 4, 5, 6, 7 or more coils may be used.

Referring to the embodiment of Figure 31, the stationary iron housing 10 may contain the driver coil pack with a first coil 12 flanked by iron spacers 14 which concentrate the magnetic flux at the inner diameter creating magnetic poles. The inner insulating housing 16 isolates the penetrating member 18 and iron core 20 from the coils and provides a smooth, low friction guide surface. The penetrating member guide 22 further centers the penetrating member 18 and iron core 20. The penetrating member 18 is protracted and retracted by alternating the current between the first coil 12, the middle coil, and the third coil to attract the iron core 20. Reversing the coil sequence and attracting the core and penetrating member back into the housing retracts the penetrating member. The penetrating member guide 22 also serves as a stop for the iron core 20 mounted to the penetrating member 18.

As discussed above, tissue penetration devices which employ spring or cam driving methods have a symmetrical or nearly symmetrical actuation displacement and velocity profiles on the advancement and retraction of the penetrating member as shown in Figures 2 and 3. In most of the available lancet devices, once the launch is initiated, the stored energy determines the velocity profile until the energy is dissipated.

Controlling impact, retraction velocity, and dwell time of the penetrating member within the tissue can be useful in order to achieve a high success rate while accommodating variations in skin properties and minimize pain. Advantages can be achieved by taking into account of the fact that tissue dwell time is related to the amount of skin deformation as the penetrating member tries to puncture the surface of the skin and variance in skin deformation from patient to patient based on skin hydration.

In this embodiment, the ability to control velocity and depth of penetration may be achieved by use of a controllable force driver where feedback is an integral part of driver control. Such drivers can control either metal or polymeric penetrating members or any other type of tissue penetration element. The dynamic control of such a driver is illustrated in Figure 2C which illustrates an embodiment of a controlled displacement profile and Figure 32D which illustrates an embodiment of a the controlled velocity profile. These are compared to Figures 32A and 32B, which illustrate embodiments of displacement and velocity profiles, respectively, of a harmonic spring/mass powered driver. Reduced pain can be achieved by using impact velocities of greater than about 2 m/s entry of a tissue penetrating element, such as a lancet, into tissue. Other suitable embodiments of the penetrating member driver are described in commonly assigned, copending U.S. Patent Application Ser. No. 10/127,395, (Attorney Docket No. 38187-2551) filed April 19, 2002 and previously incorporated herein.

Figure 33 illustrates the operation of a feedback loop using a processor 60. The processor 60 stores profiles 62 in non-volatile memory. A user inputs information 64 about the desired circumstances or parameters for a lancing event. The processor 60 selects a driver profile 62 from a set of alternative driver profiles that have been preprogrammed in the processor 60 based on typical or desired tissue penetration device performance determined through testing at the factory or as programmed in by the operator. The processor 60 may customize by either scaling or modifying the profile based on additional user input information 64. Once the processor has chosen and customized the profile, the processor 60 is ready to modulate the power from the power supply 66 to the penetrating member driver 68 through an amplifier 70. The processor 60 may measure the location of the penetrating member 72 using a position sensing mechanism 74 through an analog to digital converter 76 linear encoder or other such transducer. Examples of position sensing mechanisms have been described in the

embodiments above and may be found in the specification for commonly assigned, copending U.S. Patent Application Ser. No. 10/127,395, (Attorney Docket No. 38187-2551) filed April 19, 2002 and previously incorporated herein. The processor 60 calculates the movement of the penetrating member by comparing the actual profile of the penetrating member to the predetermined profile. The processor 60 modulates the power to the penetrating member driver 68 through a signal generator 78, which may control the amplifier 70 so that the actual velocity profile of the penetrating member does not exceed the predetermined profile by more than a preset error limit. The error limit is the accuracy in the control of the penetrating member.

After the lancing event, the processor 60 can allow the user to rank the results of the lancing event. The processor 60 stores these results and constructs a database 80 for the individual user. Using the database 79, the processor 60 calculates the profile traits such as degree of painlessness, success rate, and blood volume for various profiles 62 depending on user input information 64 to optimize the profile to the individual user for subsequent lancing cycles. These profile traits depend on the characteristic phases of penetrating member advancement and retraction. The processor 60 uses these calculations to optimize profiles 62 for each user. In addition to user input information 64, an internal clock allows storage in the database 79 of information such as the time of day to generate a time stamp for the lancing event and the time between lancing events to anticipate the user's diurnal needs. The database stores information and statistics for each user and each profile that particular user uses.

In addition to varying the profiles, the processor 60 can be used to calculate the appropriate penetrating member diameter and geometry suitable to realize the blood volume required by the user. For example, if the user requires about 1-5 microliter volume of blood, the processor 60 may select a 200 micron diameter penetrating member to achieve these results. For each class of lancet, both diameter and lancet tip geometry, is stored in the processor 60 to correspond with upper and lower limits of attainable blood volume based on the predetermined displacement and velocity profiles.

The lancing device is capable of prompting the user for information at the beginning and the end of the lancing event to more adequately suit the user. The goal is to either change to a different profile or modify an existing profile. Once the profile is set, the force driving the penetrating member is varied during advancement and retraction

to follow the profile. The method of lancing using the lancing device comprises selecting a profile, lancing according to the selected profile, determining lancing profile traits for each characteristic phase of the lancing cycle, and optimizing profile traits for subsequent lancing events.

Figure 34 illustrates an embodiment of a tissue penetration device, more specifically, a lancing device 80 that includes a controllable driver 179 coupled to a tissue penetration element. The lancing device 80 has a proximal end 81 and a distal end 82. At the distal end 82 is the tissue penetration element in the form of a penetrating member 83, which is coupled to an elongate coupler shaft 84 by a drive coupler 85. The elongate coupler shaft 84 has a proximal end 86 and a distal end 87. A driver coil pack 88 is disposed about the elongate coupler shaft 84 proximal of the penetrating member 83. A position sensor 91 is disposed about a proximal portion 92 of the elongate coupler shaft 84 and an electrical conductor 94 electrically couples a processor 93 to the position sensor 91. The elongate coupler shaft 84 driven by the driver coil pack 88 controlled by the position sensor 91 and processor 93 form the controllable driver, specifically, a controllable electromagnetic driver.

Referring to Figure 35, the lancing device 80 can be seen in more detail, in partial longitudinal section. The penetrating member 83 has a proximal end 95 and a distal end 96 with a sharpened point at the distal end 96 of the penetrating member 83 and a drive head 98 disposed at the proximal end 95 of the penetrating member 83. A penetrating member shaft 201 is disposed between the drive head 98 and the sharpened point 97. The penetrating member shaft 201 may be comprised of stainless steel, or any other suitable material or alloy and have a transverse dimension of about 0.1 to about 0.4 mm. The penetrating member shaft may have a length of about 3 mm to about 50 mm, specifically, about 15 mm to about 20 mm. The drive head 98 of the penetrating member 83 is an enlarged portion having a transverse dimension greater than a transverse dimension of the penetrating member shaft 201 distal of the drive head 98. This configuration allows the drive head 98 to be mechanically captured by the drive coupler 85. The drive head 98 may have a transverse dimension of about 0.5 to about 2 mm.

A magnetic member 102 is secured to the elongate coupler shaft 84 proximal of the drive coupler 85 on a distal portion 203 of the elongate coupler shaft 84. The magnetic member 102 is a substantially cylindrical piece of magnetic material having an

axial lumen 204 extending the length of the magnetic member 102. The magnetic member 102 has an outer transverse dimension that allows the magnetic member 102 to slide easily within an axial lumen 105 of a low friction, possibly lubricious, polymer guide tube 105' disposed within the driver coil pack 88. The magnetic member 102 may have an outer transverse dimension of about 1.0 to about 5.0 mm, specifically, about 2.3 to about 2.5 mm. The magnetic member 102 may have a length of about 3.0 to about 5.0 mm, specifically, about 4.7 to about 4.9 mm. The magnetic member 102 can be made from a variety of magnetic materials including ferrous metals such as ferrous steel, iron, ferrite, or the like. The magnetic member 102 may be secured to the distal portion 203 of the elongate coupler shaft 84 by a variety of methods including adhesive or epoxy bonding, welding, crimping or any other suitable method.

Proximal of the magnetic member 102, an optical encoder flag 206 is secured to the elongate coupler shaft 84. The optical encoder flag 206 is configured to move within a slot 107 in the position sensor 91. The slot 107 of the position sensor 91 is formed between a first body portion 108 and a second body portion 109 of the position sensor 91. The slot 107 may have separation width of about 1.5 to about 2.0 mm. The optical encoder flag 206 can have a length of about 14 to about 18 mm, a width of about 3 to about 5 mm and a thickness of about 0.04 to about 0.06 mm.

The optical encoder flag 206 interacts with various optical beams generated by LEDs disposed on or in the position sensor body portions 108 and 109 in a predetermined manner. The interaction of the optical beams generated by the LEDs of the position sensor 91 generates a signal that indicates the longitudinal position of the optical flag 206 relative to the position sensor 91 with a substantially high degree of resolution. The resolution of the position sensor 91 may be about 200 to about 400 cycles per inch, specifically, about 350 to about 370 cycles per inch. The position sensor 91 may have a speed response time (position/time resolution) of 0 to about 120,000 Hz, where one dark and light stripe of the flag constitutes one Hertz, or cycle per second. The position of the optical encoder flag 206 relative to the magnetic member 102, driver coil pack 88 and position sensor 91 is such that the optical encoder 91 can provide precise positional information about the penetrating member 83 over the entire length of the penetrating member's power stroke.

An optical encoder that is suitable for the position sensor 91 is a linear optical incremental encoder, model HEDS 9200, manufactured by Agilent Technologies. The model HEDS 9200 may have a length of about 20 to about 30 mm, a width of about 8 to about 12 mm, and a height of about 9 to about 11 mm. Although the position sensor 91 illustrated is a linear optical incremental encoder, other suitable position sensor embodiments could be used, provided they possess the requisite positional resolution and time response. The HEDS 9200 is a two channel device where the channels are 90 degrees out of phase with each other. This results in a resolution of four times the basic cycle of the flag. These quadrature outputs make it possible for the processor to determine the direction of penetrating member travel. Other suitable position sensors include capacitive encoders, analog reflective sensors, such as the reflective position sensor discussed above, and the like.

A coupler shaft guide 111 is disposed towards the proximal end 81 of the lancing device 80. The guide 111 has a guide lumen 112 disposed in the guide 111 to slidably accept the proximal portion 92 of the elongate coupler shaft 84. The guide 111 keeps the elongate coupler shaft 84 centered horizontally and vertically in the slot 102 of the optical encoder 91.

Referring now to Figures 36A-36G, in one embodiment, the processor determines that the skin has been contacted when the end tip of the penetrating member has moved a predetermined distance with respect to its initial position. If the distance from the tip 961 of the penetrating member 183 to the target tissue 233 is known prior to initiation of penetrating member 183 movement, the initial position of the penetrating member 183 is fixed and known, and the movement and position of the penetrating member 183 can be accurately measured during a lancing cycle, then the position and time of penetrating member contact can be determined. This method requires an accurate measurement of the distance between the penetrating member tip 196 and the patient's skin 233 when the penetrating member 183 is in the zero time or initial position. This can be accomplished in a number of ways. One way is to control all of the mechanical parameters that influence the distance from the penetrating member tip 196 to the patient's tissue or a surface of the lancing device 180 that will contact the patient's skin 233. This could include the start position of the magnetic member 202, magnetic path tolerance, magnetic member 202 dimensions, driver coil pack 188 location within the lancing device 180 as a

whole, length of the elongate coupling shaft 184, placement of the magnetic member 202 on the elongate coupling shaft 184, length of the penetrating member 183 etc. If all these parameters, as well as others can be suitably controlled in manufacturing with a tolerance stack-up that is acceptable, then the distance from the penetrating member tip 196 to the target tissue 233 can be determined at the time of manufacture of the lancing device 180. The distance could then be programmed into the memory of the processor 193. If an adjustable feature is added to the lancing device 180, such as an adjustable length elongate coupling shaft 184, this can accommodate variations in all of the parameters noted above, except length of the penetrating member 183. An electronic alternative to this mechanical approach would be to calibrate a stored memory contact point into the memory of the processor 193 during manufacture based on the mechanical parameters described above.

In another embodiment, moving the penetrating member tip 196 to the target tissue 233 very slowly and gently touching the skin 233 prior to actuation can accomplish the distance from the penetrating member tip 196 to the tissue 233. The position sensor can accurately measure the distance from the initialization point to the point of contact, where the resistance to advancement of the penetrating member 183 stops the penetrating member movement. The penetrating member 183 is then retracted to the initialization point having measured the distance to the target tissue 233 without creating any discomfort to the user.

Referring now to Figure 37, a still further embodiment of a cartridge according to the present invention will be described. Figure 37 shows one embodiment of a cartridge 900 which may be removably inserted into an apparatus for driving penetrating members to pierce skin or tissue. The cartridge 900 has a plurality of penetrating members 902 that may be individually or otherwise selectively actuated so that the penetrating members 902 may extend outward from the cartridge, as indicated by arrow 904, to penetrate tissue. In the present embodiment, the cartridge 900 may be based on a flat disc with a number of penetrating members such as, but in no way limited to, (25, 50, 75, 100, ...) arranged radially on the disc or cartridge 800. It should be understood that although the cartridge 900 is shown as a disc or a disc-shaped housing, other shapes or configurations of the cartridge may also work without departing from the spirit of the present invention of

placing a plurality of penetrating members to be engaged, singly or in some combination, by a penetrating member driver.

Each penetrating member 902 may be contained in a cavity 906 in the cartridge 900 with the penetrating member's sharpened end facing radially outward and may be in the same plane as that of the cartridge. The cavity 906 may be molded, pressed, forged, or otherwise formed in the cartridge. Although not limited in this manner, the ends of the cavities 906 may be divided into individual fingers (such as one for each cavity) on the outer periphery of the disc. The particular shape of each cavity 906 may be designed to suit the size or shape of the penetrating member therein or the amount of space desired for placement of the analyte detecting members 808. For example and not limitation, the cavity 906 may have a V-shaped cross-section, a U-shaped cross-section, C-shaped cross-section, a multi-level cross section or the other cross-sections. The opening 810 through which a penetrating member 902 may exit to penetrate tissue may also have a variety of shapes, such as but not limited to, a circular opening, a square or rectangular opening, a U-shaped opening, a narrow opening that only allows the penetrating member to pass, an opening with more clearance on the sides, a slit, a configuration as shown in Figure 75, or the other shapes.

In this embodiment, after actuation, the penetrating member 902 is returned into the cartridge and may be held within the cartridge 900 in a manner so that it is not able to be used again. By way of example and not limitation, a used penetrating member may be returned into the cartridge and held by the launcher in position until the next lancing event. At the time of the next lancing, the launcher may disengage the used penetrating member with the cartridge 900 turned or indexed to the next clean penetrating member such that the cavity holding the used penetrating member is position so that it is not accessible to the user (i.e. turn away from a penetrating member exit opening). In some embodiments, the tip of a used penetrating member may be driven into a protective stop that hold the penetrating member in place after use. The cartridge 900 is replaceable with a new cartridge 900 once all the penetrating members have been used or at such other time or condition as deemed desirable by the user.

Referring still to the embodiment in Figure 37, the cartridge 900 may provide sterile environments for penetrating members via seals, foils, covers, polymeric, or similar materials used to seal the cavities and provide enclosed areas for the penetrating

members to rest in. In the present embodiment, a foil or seal layer 920 is applied to one surface of the cartridge 900. The seal layer 920 may be made of a variety of materials such as a metallic foil or other seal materials and may be of a tensile strength and other quality that may provide a sealed, sterile environment until the seal layer 920 is penetrated by a suitable or penetrating device providing a preselected or selected amount of force to open the sealed, sterile environment. Each cavity 906 may be individually sealed with a layer 920 in a manner such that the opening of one cavity does not interfere with the sterility in an adjacent or other cavity in the cartridge 800. As seen in the embodiment of Figure 37, the seal layer 920 may be a planar material that is adhered to a top surface of the cartridge 800.

Depending on the orientation of the cartridge 900 in the penetrating member driver apparatus, the seal layer 920 may be on the top surface, side surface, bottom surface, or other positioned surface. For ease of illustration and discussion of the embodiment of Figure 37, the layer 920 is placed on a top surface of the cartridge 800. The cavities 906 holding the penetrating members 902 are sealed on by the foil layer 920 and thus create the sterile environments for the penetrating members. The foil layer 920 may seal a plurality of cavities 906 or only a select number of cavities as desired.

In a still further feature of Figure 37, the cartridge 900 may optionally include a plurality of analyte detecting members 908 on a substrate 922 which may be attached to a bottom surface of the cartridge 900. The substrate may be made of a material such as, but not limited to, a polymer, a foil, or other material suitable for attaching to a cartridge and holding the analyte detecting members 908. As seen in Figure 37, the substrate 922 may hold a plurality of analyte detecting members, such as but not limited to, about 10-50, 50-100, or other combinations of analyte detecting members. This facilitates the assembly and integration of analyte detecting members 908 with cartridge 900. These analyte detecting members 908 may enable an integrated body fluid sampling system where the penetrating members 902 create a wound tract in a target tissue, which expresses body fluid that flows into the cartridge for analyte detection by at least one of the analyte detecting members 908. The substrate 922 may contain any number of analyte detecting members 908 suitable for detecting analytes in cartridge having a plurality of cavities 906. In one embodiment, many analyte detecting members 908 may be printed onto a single substrate 922 which is then adhered to the cartridge to facilitate manufacturing and

simplify assembly. The analyte detecting members 908 may be electrochemical in nature. The analyte detecting members 908 may further contain enzymes, dyes, or other detectors which react when exposed to the desired analyte. Additionally, the analyte detecting members 908 may comprise of clear optical windows that allow light to pass into the body fluid for analyte analysis. The number, location, and type of analyte detecting member 908 may be varied as desired, based in part on the design of the cartridge, number of analytes to be measured, the need for analyte detecting member calibration, and the sensitivity of the analyte detecting members. If the cartridge 900 uses an analyte detecting member arrangement where the analyte detecting members are on a substrate attached to the bottom of the cartridge, there may be through holes (as shown in Figure 76), wicking elements, capillary tube or other devices on the cartridge 900 to allow body fluid to flow from the cartridge to the analyte detecting members 908 for analysis. In other configurations, the analyte detecting members 908 may be printed, formed, or otherwise located directly in the cavities housing the penetrating members 902 or areas on the cartridge surface that receive blood after lancing.

The use of the seal layer 920 and substrate or analyte detecting member layer 822 may facilitate the manufacture of these cartridges 10. For example, a single seal layer 920 may be adhered, attached, or otherwise coupled to the cartridge 900 as indicated by arrows 924 to seal many of the cavities 906 at one time. A sheet 922 of analyte detecting members may also be adhered, attached, or otherwise coupled to the cartridge 900 as indicated by arrows 925 to provide many analyte detecting members on the cartridge at one time. During manufacturing of one embodiment of the present invention, the cartridge 900 may be loaded with penetrating members 902, sealed with layer 920 and a temporary layer (not shown) on the bottom where substrate 922 would later go, to provide a sealed environment for the penetrating members. This assembly with the temporary bottom layer is then taken to be sterilized. After sterilization, the assembly is taken to a clean room (or it may already be in a clean room or equivalent environment) where the temporary bottom layer is removed and the substrate 922 with analyte detecting members is coupled to the cartridge as shown in Figure 37. This process allows for the sterile assembly of the cartridge with the penetrating members 902 using processes and/or temperatures that may degrade the accuracy or functionality of the analyte detecting members on substrate 922. As a nonlimiting example, the entire cartridge 900 may then

be placed in a further sealed container such as a pouch, bag, plastic molded container, etc...to facilitate contact, improve ruggedness, and/or allow for easier handling.

In some embodiments, more than one seal layer 920 may be used to seal the cavities 906. As examples of some embodiments, multiple layers may be placed over each cavity 906, half or some selected portion of the cavities may be sealed with one layer with the other half or selected portion of the cavities sealed with another sheet or layer, different shaped cavities may use different seal layer, or the like. The seal layer 920 may have different physical properties, such as those covering the penetrating members 902 near the end of the cartridge may have a different color such as red to indicate to the user (if visually inspectable) that the user is down to say 10, 5, or other number of penetrating members before the cartridge should be changed out.

Referring now to Figure 38, one embodiment of an apparatus 980 using a radial cartridge 900 with a penetrating member driver 982 is shown. A contoured surface 884 is located near a penetrating member exit port 986, allowing for a patient to place their finger in position for lancing. Although not shown, the apparatus 980 may include a human readable or other type of visual display to relay status to the user. The display may also show measured analyte levels or other measurement or feedback to the user without the need to plug apparatus 980 or a separate test strip into a separate analyte reader device. The apparatus 980 may include a processor or other logic for actuating the penetrating member or for measuring the analyte levels. The cartridge 900 may be loaded into the apparatus 980 by opening a top housing of the apparatus which may be hinged or removably coupled to a bottom housing. The cartridge 900 may also drawn into the apparatus 980 using a loading mechanism similar in spirit to that found on a compact disc player or the like. In such an embodiment, the apparatus may have a slot (similar to a CD player in an automobile) that allows for the insertion of the cartridge 900 into the apparatus 980 which is then automatically loaded into position or otherwise seated in the apparatus for operation therein. The loading mechanism may be mechanically powered or electrically powered. In some embodiments, the loading mechanism may use a loading tray in addition to the slot. The slot may be placed higher on the housing so that the cartridge 900 will have enough clearance to be loaded into the device and then dropped down over the penetrating member driver 982. The cartridge 900 may have an indicator mark or indexing device that allows the cartridge to be properly aligned by the loading

mechanism or an aligning mechanism once the cartridge 900 is placed into the apparatus 980. The cartridge 900 may rest on a radial platform that rotates about the penetrating member driver 982, thus providing a method for advancing the cartridge to bring unused penetrating members to engagement with the penetrating member driver. The cartridge 800 on its underside or other surface, may shaped or contoured such as with notches, grooves, tractor holes, optical markers, or the like to facilitate handling and/or indexing of the cartridge. These shapes or surfaces may also be varied so as to indicate that the cartridge is almost out of unused penetrating members, that there are only five penetrating members left, or some other cartridge status indicator as desired.

A suitable method and apparatus for loading penetrating members has been described previously in commonly assigned, copending U.S. patent applications Attorney Docket 38187-2589 and 38187-2590, and are included here by reference for all purposes. Suitable devices for engaging the penetrating members and for removing protective materials associated with the penetrating member cavity are described in commonly assigned, copending U.S. patent applications Attorney Docket 38187-2601 and 38187-2602, and are included here by reference for all purposes. For example in the embodiment of Figure 37, the foil or seal layer 920 may cover the cavity by extending across the cavity along a top surface 990 and down along the angled surface 892 to provide a sealed, sterile environment for the penetrating member and sensors therein. A piercing element described in U.S. patent applications Attorney Docket 38187-2602 has a piercing element and then a shaped portion behind the element which pushes the foil to the sides of the cavity or other position so that the penetrating member 902 may be actuated and body fluid may flow into the cavity.

Referring now to Figure 39, one embodiment of a device that may use a disc 900 is shown. This embodiment of device 1000 include a display 1002 that shows lancing performance and setting such as penetration depth setting the like. Various buttons 1004 may also be placed on the housing to adjust settings and/or to activate lancing.

It should be understood that device 1000 may include a processor for implementing any of the control methodologies set forth herein. The processor may control the penetrating member driver and/or active braking device such a pads, stops, dampers, dashpots and other mechanism to control penetrating member speed. The characteristic phases of penetrating member advancement and retraction can be plotted on

a graph of force versus time illustrating the force exerted by the penetrating member driver on the penetrating member to achieve the desired displacement and velocity profile. The characteristic phases are the penetrating member introduction phase A-C where the penetrating member is longitudinally advanced into the skin, the penetrating member rest phase D where the penetrating member terminates its longitudinal movement reaching its maximum depth and becoming relatively stationary, and the penetrating member retraction phase E-G where the penetrating member is longitudinally retracted out of the skin. The duration of the penetrating member retraction phase E-G is longer than the duration of the penetrating member introduction phase A-C, which in turn is longer than the duration of the penetrating member rest phase D.

The introduction phase further comprises a penetrating member launch phase prior to A when the penetrating member is longitudinally moving through air toward the skin, a tissue contact phase at the beginning of A when the distal end of the penetrating member makes initial contact with the skin, a tissue deformation phase A when the skin bends depending on its elastic properties which are related to hydration and thickness, a tissue lancing phase which comprises when the penetrating member hits the inflection point on the skin and begins to cut the skin B and the penetrating member continues cutting the skin C. The penetrating member rest phase D is the limit of the penetration of the penetrating member into the skin. Pain is reduced by minimizing the duration of the penetrating member introduction phase A-C so that there is a fast incision to a certain penetration depth regardless of the duration of the deformation phase A and inflection point cutting B which will vary from user to user. Success rate is increased by measuring the exact depth of penetration from inflection point B to the limit of penetration in the penetrating member rest phase D. This measurement allows the penetrating member to always, or at least reliably, hit the capillary beds which are a known distance underneath the surface of the skin.

The penetrating member retraction phase further comprises a primary retraction phase E when the skin pushes the penetrating member out of the wound tract, a secondary retraction phase F when the penetrating member starts to become dislodged and pulls in the opposite direction of the skin, and penetrating member exit phase G when the penetrating member becomes free of the skin. Primary retraction is the result of exerting a decreasing force to pull the penetrating member out of the skin as the penetrating

member pulls away from the finger. Secondary retraction is the result of exerting a force in the opposite direction to dislodge the penetrating member. Control is necessary to keep the wound tract open as blood flows up the wound tract. Blood volume is increased by using a uniform velocity to retract the penetrating member during the penetrating member retraction phase E-G regardless of the force required for the primary retraction phase E or secondary retraction phase F, either of which may vary from user to user depending on the properties of the user's skin.

Displacement versus time profile of a penetrating member for a controlled penetrating member retraction can be plotted. Velocity vs. time profile of the penetrating member for the controlled retraction can also be plotted. The penetrating member driver controls penetrating member displacement and velocity at several steps in the lancing cycle, including when the penetrating member cuts the blood vessels to allow blood to pool 2130, and as the penetrating member retracts, regulating the retraction rate to allow the blood to flood the wound tract while keeping the wound flap from sealing the channel 2132 to permit blood to exit the wound.

The tenting process and retrograde motion of the penetrating member during the lancing cycle can be illustrated graphically which shows both a velocity versus time graph and a position versus time graph of a penetrating member tip during a lancing cycle that includes elastic and inelastic tenting. From point 0 to point A, the penetrating member is being accelerated from the initialization position or zero position. From point A to point B, the penetrating member is in ballistic or coasting mode, with no additional power being delivered. At point B, the penetrating member tip contacts the tissue and begins to tent the skin until it reaches a displacement C. As the penetrating member tip approaches maximum displacement, braking force is applied to the penetrating member until the penetrating member comes to a stop at point D. The penetrating member then recoils in a retrograde direction during the settling phase of the lancing cycle indicated between D and E. Note that the magnitude of inelastic tenting indicated in Figure 148 is exaggerated for purposes of illustration.

The amount of inelastic tenting indicated by Z tends to be fairly consistent and small compared to the magnitude of the elastic tenting. Generally, the amount of inelastic tenting Z can be about 120 to about 140 microns. As the magnitude of the inelastic tenting has a fairly constant value and is small compared to the magnitude of the elastic

tenting for most patients and skin types, the value for the total amount of tenting for the penetration stroke of the penetrating member is effectively equal to the rearward displacement of the penetrating member during the settling phase as measured by the processor 193 plus a predetermined value for the inelastic recoil, such as 130 microns. Inelastic recoil for some embodiments can be about 100 to about 200 microns. The ability to measure the magnitude of skin tenting for a patient is important to controlling the depth of penetration of the penetrating member tip as the skin is generally known to vary in elasticity and other parameters due to age, time of day, level of hydration, gender and pathological state.

This value for total tenting for the lancing cycle can then be used to determine the various characteristics of the patient's skin. Once a body of tenting data is obtained for a given patient, this data can be analyzed in order to predict the total penetrating member displacement, from the point of skin contact, necessary for a successful lancing procedure. This enables the tissue penetration device to achieve a high success rate and minimize pain for the user. A rolling average table can be used to collect and store the tenting data for a patient with a pointer to the last entry in the table. When a new entry is input, it can replace the entry at the pointer and the pointer advances to the next value. When an average is desired, all the values are added and the sum divided by the total number of entries by the processor 193. Similar techniques involving exponential decay (multiply by .95, add 0.05 times current value, etc.) are also possible.

With regard to tenting of skin generally, some typical values relating to penetration depth are now discussed. A cross sectional view of the layers of the skin can be shown. In order to reliably obtain a useable sample of blood from the skin, it is desirable to have the penetrating member tip reach the venuolar plexus of the skin. The stratum corneum is typically about 0.1 to about 0.6 mm thick and the distance from the top of the dermis to the venuole plexus can be from about 0.3 to about 1.4 mm. Elastic tenting can have a magnitude of up to about 2 mm or so, specifically, about 0.2 to about 2.0 mm, with an average magnitude of about 1 mm. This means that the amount of penetrating member displacement necessary to overcome the tenting can have a magnitude greater than the thickness of skin necessary to penetrate in order to reach the venuolar plexus. The total penetrating member displacement from point of initial skin contact may have an average value of about 1.7 to about 2.1 mm. In some embodiments,

penetration depth and maximum penetration depth may be about 0.5 mm to about 5 mm, specifically, about 1 mm to about 3 mm. In some embodiments, a maximum penetration depth of about 0.5 to about 3 mm is useful.

In some embodiments, the penetrating member is withdrawn with less force and a lower speed than the force and speed during the penetration portion of the operation cycle. Withdrawal speed of the penetrating member in some embodiments can be about 0.004 to about 0.5 m/s, specifically, about 0.006 to about 0.01 m/s. In other embodiments, useful withdrawal velocities can be about 0.001 to about 0.02 meters per second, specifically, about 0.001 to about 0.01 meters per second. For embodiments that use a relatively slow withdrawal velocity compared to the penetration velocity, the withdrawal velocity may up to about 0.02 meters per second. For such embodiments, a ratio of the average penetration velocity relative to the average withdrawal velocity can be about 100 to about 1000. In embodiments where a relatively slow withdrawal velocity is not important, a withdrawal velocity of about 2 to about 10 meters per second may be used.

Another example of an embodiment of a velocity profile for a penetrating member can be seen shown, which illustrates a penetrating member profile with a fast entry velocity and a slow withdrawal velocity. A lancing profile showing velocity of the penetrating member versus position. The lancing profile starts at zero time and position and shows acceleration of the penetrating member towards the tissue from the electromagnetic force generated from the electromagnetic driver. At point A, the power is shut off and the penetrating member begins to coast until it reaches the skin indicated by B at which point, the velocity begins to decrease. At point C, the penetrating member has reached maximum displacement and settles momentarily, typically for a time of about 8 milliseconds.

A retrograde withdrawal force is then imposed on the penetrating member by the controllable driver, which is controlled by the processor to maintain a withdrawal velocity of no more than about 0.006 to about 0.01 meters/second. The same cycle is illustrated in the velocity versus time plot where the penetrating member is accelerated from the start point to point A. The penetrating member coasts from A to B where the penetrating member tip contacts tissue 233. The penetrating member tip then penetrates the tissue and slows with braking force eventually applied as the maximum penetration depth is

approached. The penetrating member is stopped and settling between C and D. At D, the withdrawal phase begins and the penetrating member is slowly withdrawn until it returns to the initialization point shown by E. Note that retrograde recoil from elastic and inelastic tenting was not shown in the lancing profiles for purpose of illustration and clarity.

In another embodiment, the withdrawal phase may use a dual speed profile, with the slow .006 to .01 meter per second speed used until the penetrating member is withdrawn past the contact point with the tissue, then a faster speed of .01 to 1 meters per second may be used to shorten the complete cycle.

While the invention has been described and illustrated with reference to certain particular embodiments thereof, those skilled in the art will appreciate that various adaptations, changes, modifications, substitutions, deletions, or additions of procedures and protocols may be made without departing from the spirit and scope of the invention. For example, with any of the above embodiments, the location of the penetrating member drive device may be varied, relative to the penetrating members or the cartridge. With any of the above embodiments, the penetrating member tips may be uncovered during actuation (i.e. penetrating members do not pierce the penetrating member enclosure or protective foil during launch). With any of the above embodiments, the penetrating members may be a bare penetrating member during launch. With any of the above embodiments, the penetrating members may be bare penetrating members prior to launch as this may allow for significantly tighter densities of penetrating members. In some embodiments, the penetrating members may be bent, curved, textured, shaped, or otherwise treated at a proximal end or area to facilitate handling by an actuator. The penetrating member may be configured to have a notch or groove to facilitate coupling to a gripper. The notch or groove may be formed along an elongate portion of the penetrating member. With any of the above embodiments, the cavity may be on the bottom or the top of the cartridge, with the gripper on the other side. In some embodiments, analyte detecting members may be printed on the top, bottom, or side of the cavities. The front end of the cartridge maybe in contact with a user during lancing. The same driver may be used for advancing and retraction of the penetrating member. The penetrating member may have a diameters and length suitable for obtaining the blood volumes described herein. The penetrating member driver may also be in substantially

the same plane as the cartridge. The driver may use a through hole or other opening to engage a proximal end of a penetrating member to actuate the penetrating member along a path into and out of the tissue. The present penetrating member may be used with multiple penetrating member cartridges or single penetrating member cartridges. They may be used with penetrating member cartridges which are oval, square, rectangular, triangular, hexagonal, polygonal, or other shaped or combinations of shapes. The penetrating members may be used in a bandolier configuration or held in a tape containing a plurality of penetrating members between two tapes. The penetrating members may be used electric drive devices or conventional spring-based launchers.

While the invention has been described and illustrated with reference to certain particular embodiments thereof, those skilled in the art will appreciate that various adaptations, changes, modifications, substitutions, deletions, or additions of procedures and protocols may be made without departing from the spirit and scope of the invention. For example, with any of the above embodiments, the location of the penetrating member drive device may be varied, relative to the penetrating members or the cartridge. With any of the above embodiments, the penetrating member tips may be uncovered during actuation (i.e. penetrating members do not pierce the penetrating member enclosure or protective foil during launch). With any of the above embodiments, the penetrating members may be a bare penetrating member during launch. With any of the above embodiments, the penetrating members may be bare penetrating members prior to launch as this may allow for significantly tighter densities of penetrating members. In some embodiments, the penetrating members may be bent, curved, textured, shaped, or otherwise treated at a proximal end or area to facilitate handling by an actuator. The penetrating member may be configured to have a notch or groove to facilitate coupling to a gripper. The notch or groove may be formed along an elongate portion of the penetrating member. With any of the above embodiments, the cavity may be on the bottom or the top of the cartridge, with the gripper on the other side. In some embodiments, analyte detecting members may be printed on the top, bottom, or side of the cavities. The front end of the cartridge maybe in contact with a user during lancing. The same driver may be used for advancing and retraction of the penetrating member. The penetrating member may have a diameters and length suitable for obtaining the blood volumes described herein. The penetrating member driver may also be in substantially

the same plane as the cartridge. The driver may use a through hole or other opening to engage a proximal end of a penetrating member to actuate the penetrating member along a path into and out of the tissue.

Any of the features described in this application or any reference disclosed herein may be adapted for use with any embodiment of the present invention. For example, the devices of the present invention may also be combined for use with injection penetrating members or needles as described in commonly assigned, copending U.S. Patent Application Ser. No. 10/127,395 (Attorney Docket No. 38187-2551) filed April 19, 2002. An analyte detecting member to detect the presence of foil may also be included in the lancing apparatus. For example, if a cavity has been used before, the foil or sterility barrier will be punched. The analyte detecting member can detect if the cavity is fresh or not based on the status of the barrier. It should be understood that in optional embodiments, the sterility barrier may be designed to pierce a sterility barrier of thickness that does not dull a tip of the penetrating member. The lancing apparatus may also use improved drive mechanisms. For example, a solenoid force generator may be improved to try to increase the amount of force the solenoid can generate for a given current. A solenoid for use with the present invention may have five coils and in the present embodiment the slug is roughly the size of two coils. One change is to increase the thickness of the outer metal shell or windings surround the coils. By increasing the thickness, the flux will also be increased. The slug may be split; two smaller slugs may also be used and offset by $\frac{1}{2}$ of a coil pitch. This allows more slugs to be approaching a coil where it could be accelerated. This creates more events where a slug is approaching a coil, creating a more efficient system.

In another optional alternative embodiment, a gripper in the inner end of the protective cavity may hold the penetrating member during shipment and after use, eliminating the feature of using the foil, protective end, or other part to retain the used penetrating member. Some other advantages of the disclosed embodiments and features of additional embodiments include: same mechanism for transferring the used penetrating members to a storage area; a high number of penetrating members such as 25, 50, 75, 100, 500, or more penetrating members may be put on a disk or cartridge; molded body about a lancet becomes unnecessary; manufacturing of multiple penetrating member devices is simplified through the use of cartridges; handling is possible of bare rods metal

wires, without any additional structural features, to actuate them into tissue; maintaining extreme (better than 50 micron -lateral- and better than 20 micron vertical) precision in guiding; and storage system for new and used penetrating members, with individual cavities/slots is provided. The housing of the lancing device may also be sized to be ergonomically pleasing. In one embodiment, the device has a width of about 56 mm, a length of about 105 mm and a thickness of about 15 mm. Additionally, some embodiments of the present invention may be used with non-electrical force generators or drive mechanism. For example, the punch device and methods for releasing the penetrating members from sterile enclosures could be adapted for use with spring based launchers. The gripper using a frictional coupling may also be adapted for use with other drive technologies.

Still further optional features may be included with the present invention. For example, with any of the above embodiments, the location of the penetrating member drive device may be varied, relative to the penetrating members or the cartridge. With any of the above embodiments, the penetrating member tips may be uncovered during actuation (i.e. penetrating members do not pierce the penetrating member enclosure or protective foil during launch). The penetrating members may be a bare penetrating member during launch. In some embodiments, the penetrating member may be a patent needle. The same driver may be used for advancing and retraction of the penetrating member. Different analyte detecting members detecting different ranges of glucose concentration, different analytes, or the like may be combined for use with each penetrating member. Non-potentiometric measurement techniques may also be used for analyte detection. For example, direct electron transfer of glucose oxidase molecules adsorbed onto carbon nanotube powder microelectrode may be used to measure glucose levels. In some embodiments, the analyte detecting members may formed to flush with the cartridge so that a "well" is not formed. In some other embodiments, the analyte detecting members may formed to be substantially flush (within 200 microns or 100 microns) with the cartridge surfaces. In all methods, nanoscopic wire growth can be carried out via chemical vapor deposition (CVD). In all of the embodiments of the invention, preferred nanoscopic wires may be nanotubes. Any method useful for depositing a glucose oxidase or other analyte detection material on a nanowire or nanotube may be used with the present invention. Additionally, for some embodiments,

any of the cartridge shown above may be configured without any of the penetrating members, so that the cartridge is simply an analyte detecting device. Still further, the indexing of the cartridge may be such that adjacent cavities may not necessarily be used serially or sequentially. As a nonlimiting example, every second cavity may be used sequentially, which means that the cartridge will go through two rotations before every or substantially all of the cavities are used. As another nonlimiting example, a cavity that is 3 cavities away, 4 cavities away, or N cavities away may be the next one used. This may allow for greater separation between cavities containing penetrating members that were just used and a fresh penetrating member to be used next. For any of the embodiments herein, they may be configured to provide the various velocity profiles described.

This application cross-references commonly assigned copending U.S. Patent Applications Ser. No. 10/323,622 (Attorney Docket No. 38187-2606) filed December 18, 2002. This application is also related to commonly assigned copending U.S. Patent Applications Ser. No. 10/335,142 filed December 31, 2002. This application is also a continuation-in-part of commonly assigned, copending U.S. Patent Application Ser. No. 10/425,815 (Attorney Docket No. 38187-2663) filed May 30, 2003. This application is related to copending U.S. Patent Application Ser. No. 10/127,395 (Attorney Docket No. 38187-2551) filed April 19, 2002. This application is also a continuation-in-part of commonly assigned, copending U.S. Patent Application Ser. No. 10/237,261 (Attorney Docket No. 38187-2595) filed September 5, 2002. This application is further a continuation-in-part of commonly assigned, copending U.S. Patent Application Ser. No. 10/420,535 (Attorney Docket No. 38187-2664) filed April 21, 2003. This application is further a continuation-in-part of commonly assigned, copending U.S. Patent Application Ser. No. 10/335,142 (Attorney Docket No. 38187-2633) filed December 31, 2002. This application is further a continuation-in-part of commonly assigned, copending U.S. Patent Application Ser. No. 10/423,851 (Attorney Docket No. 38187-2657) filed April 24, 2003. All applications listed above are incorporated herein by reference for all purposes.

The publications discussed or cited herein are provided solely for their disclosure prior to the filing date of the present application. Nothing herein is to be construed as an admission that the present invention is not entitled to antedate such publication by virtue of prior invention. Further, the dates of publication provided may be different from the actual publication dates which may need to be independently confirmed. All publications

mentioned herein are incorporated herein by reference to disclose and describe the structures and/or methods in connection with which the publications are cited.

Expected variations or differences in the results are contemplated in accordance with the objects and practices of the present invention. It is intended, therefore, that the invention be defined by the scope of the claims which follow and that such claims be interpreted as broadly as is reasonable.

WHAT IS CLAIMED IS:

1. A device comprising:
a penetrating member for piercing tissue.
2. The device of claim 1 wherein the penetrating member is configured to reduce the volume or friction of a penetrating member shaft in the skin.
3. The device of claim 1 wherein the penetrating member comprises a distal tip having a first cutting facet and a second cutting facet.
4. The device of claim 1 wherein primary facet length of the penetrating member is less than about 1.0 mm.
5. The device of claim 1 wherein primary facet length of the penetrating member is more than about 2.0 mm.
6. The device of claim 1 wherein a ratio of primary facet length to side facet length is less than 2.24:0.63.
7. The device of claim 1 wherein a ratio of primary facet length to side facet length is less than 2:1.
8. The device of claim 1 wherein a ratio of primary facet length to side facet length is less than 2:1, and wherein primary facet length of the penetrating member is less than about 1.0 mm.
9. The device of claim 1 wherein the penetrating member has a primary facet length greater than about 1.60 mm.
10. The device of claim 1 wherein the penetrating member has a primary facet length greater than about 1.70 mm.
11. The device of claim 1 wherein the penetrating member has a primary facet length greater than about 1.70 mm.

12. The device of claim 1 wherein the penetrating member has a primary facet length greater than about 1.80 mm.

13. The device of claim 1 wherein the penetrating member has a primary facet length greater than about 1.90 mm.

14. The device of claim 1 wherein the penetrating member has a primary facet length greater than about 2.00 mm.

15. The device of claim 1 wherein the penetrating member has a primary facet length greater than about 2.10 mm.

16. The device of claim 1 wherein the penetrating member has a primary facet length greater than about 2.20 mm.

17. The device of claim 1 wherein the penetrating member has a primary facet angle less than about 7.0 degrees.

18. The device of claim 1 wherein the penetrating member has a primary facet angle less than about 7.5 degrees.

19. The device of claim 1 wherein the penetrating member has a bevel joint length less than about 0.24 mm.

20. The device of claim 1 wherein the penetrating member has a bevel joint angle is less than about 16 degrees.

21. The device of claim 1 wherein the penetrating member has a bevel joint angle is less than about 15.5 degrees.

22. The device of claim 1 wherein the penetrating member has a diameter less than about 0.32 mm.

23. The device of claim 1 wherein the penetrating member has a diameter less than about 0.30 mm.

24. The device of claim 1 wherein the penetrating member has a cutting efficiency sufficient to bring at least 1 micro liter of blood to a skin surface after penetrating about 600 to 800 microns into the skin.

25. The device of claim 1 wherein the penetrating member has a cutting efficiency sufficient to bring at least 1 micro liter of blood to a skin surface after penetration about 0.5 to 1.0 mm into the skin.

26. The device of claim 1 wherein the penetrating member comprises a shaft having a half-round bar stock.

27. The device of claim 1 wherein the penetrating member has a oval cross-section.

28. The device of claim 1 wherein a portion of the penetrating member has a first cross-sectional volume and a second cross-sectional volume greater than the first.

29. The device of claim 1 wherein a front end portion has a smashed end configuration.

30. The device of claim 1 wherein the penetrating member has a splined cross-section.

31. The device of claim 1 wherein the penetrating member is a bare lancet without any molded attachments.

32. The device of claim 1 wherein the penetrating member further comprises a molded attachment coupled to a shaft portion of the penetrating member.

33. The device of claim 1 further comprising an electric penetrating member drive to advance the penetrating member into tissue.

34. A cartridge containing a plurality of penetrating member as described in claim 1.

35. A radial cartridge containing a plurality of penetrating member as described in claim 1.

36. A method of body fluid sampling for use on tissue, the method comprising:

using a penetrating member having a reduced volume;

advancing said penetrating member into the tissue to create a wound channel.

37. A method for controlling depth of penetrating member motion into a patient, said method comprising:

advancing a penetrating member exhibiting reduced penetration resistance.

1/21

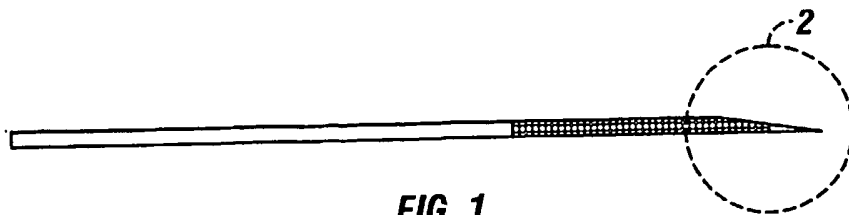

FIG. 1

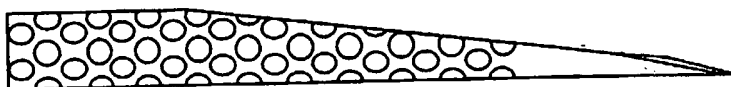

FIG. 2

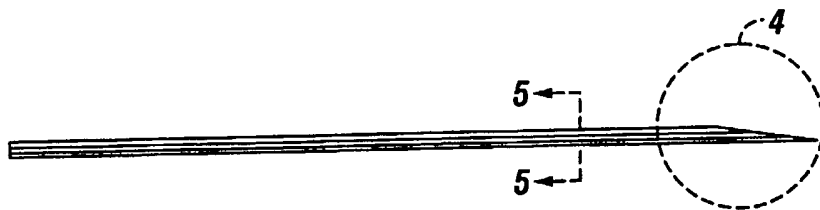

FIG. 3

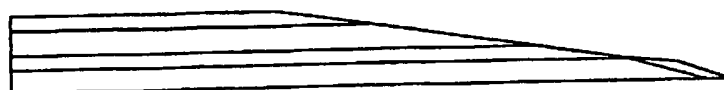

FIG. 4

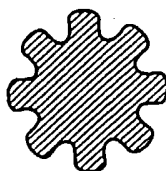
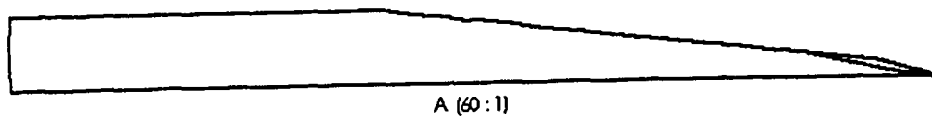

FIG. 5



FIG. 7



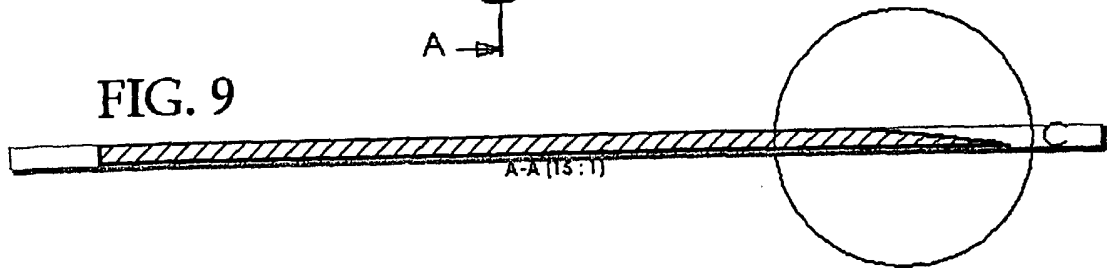
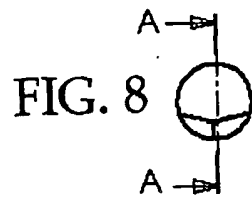
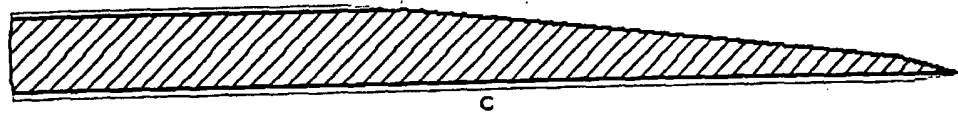

FIG. 10



4/21

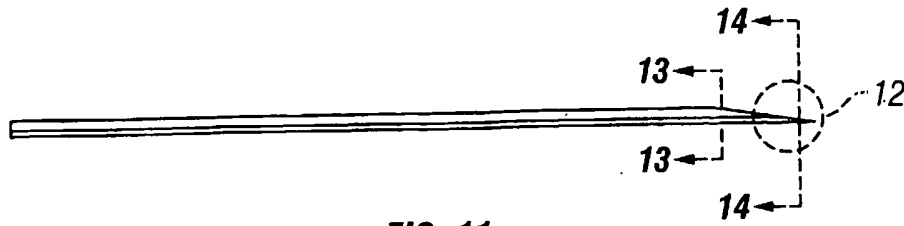

FIG. 11

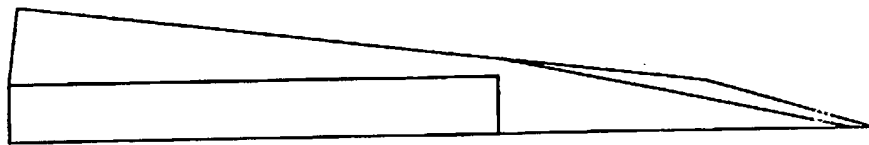

FIG. 12

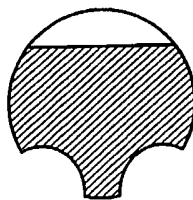

FIG. 13

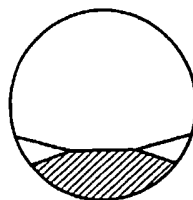

FIG. 14

5/21

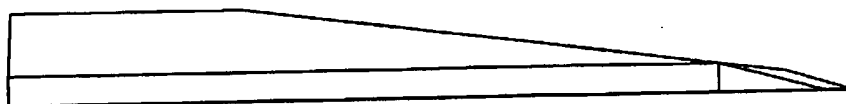
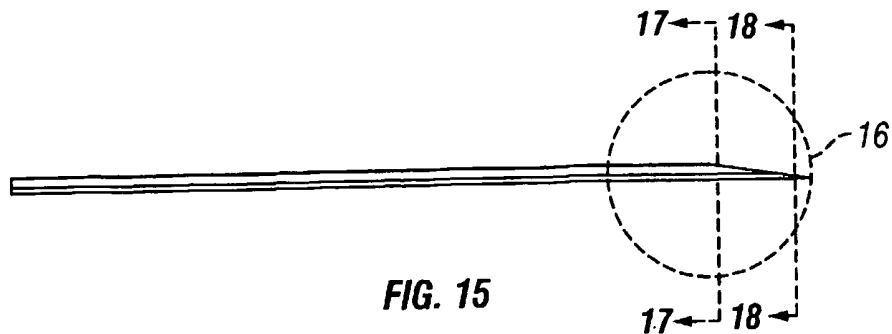

FIG. 16

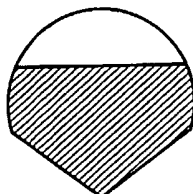

FIG. 17

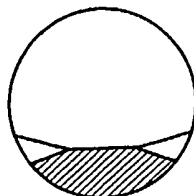

FIG. 18

6/21

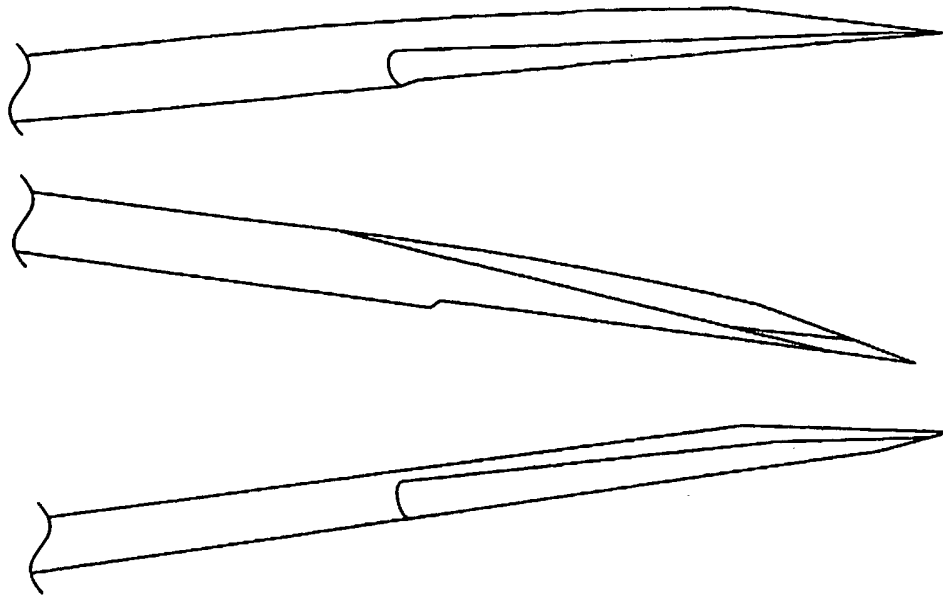

FIG. 19

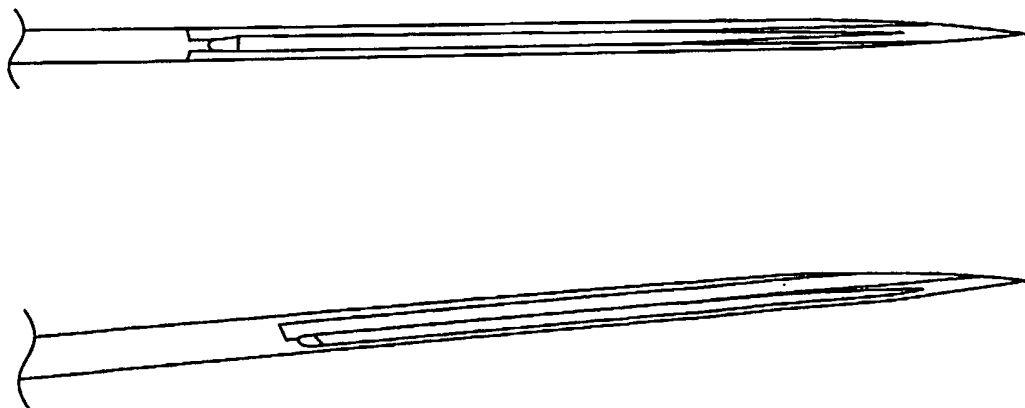

FIG. 20

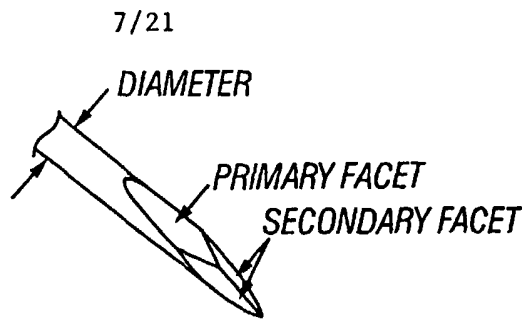

FIG. 21

DIAMETER μm	1100	1040	800	660	350	220	200	200	200	200	200	290
BLOOD μL	73	22.4	47.9	8.6	13.8	30.8	7.4	5.4	6.1	4.5	7.6	2.4
PAIN	4.5	4.5	6.3	6.3	6.1	5.6	4.4	4.6	4.1	3.95	4.5	4.5

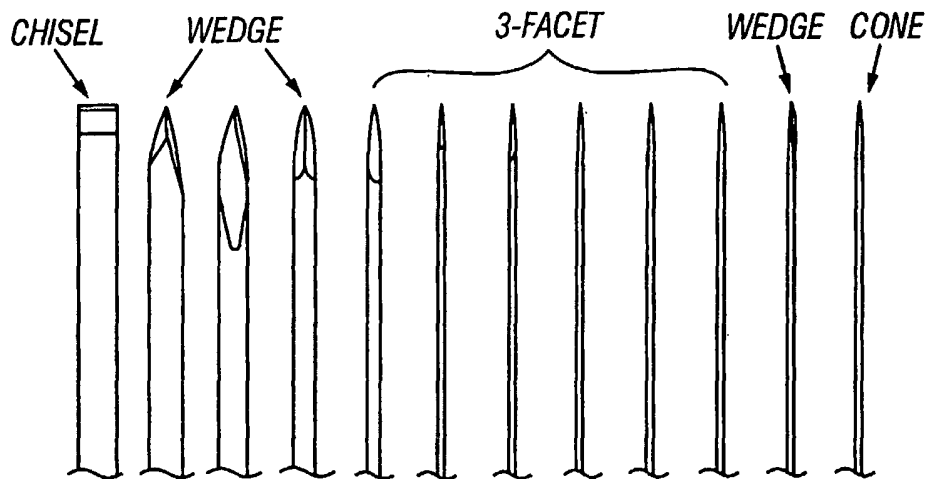

FIG. 22

Figure 23A

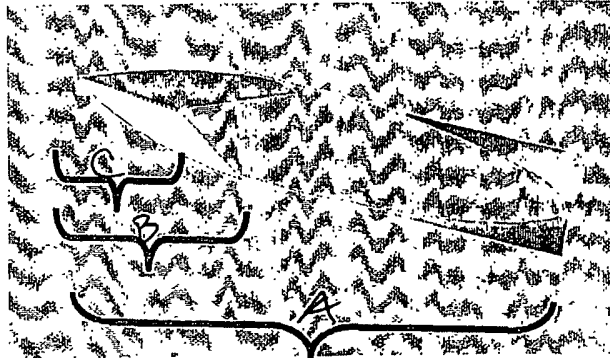
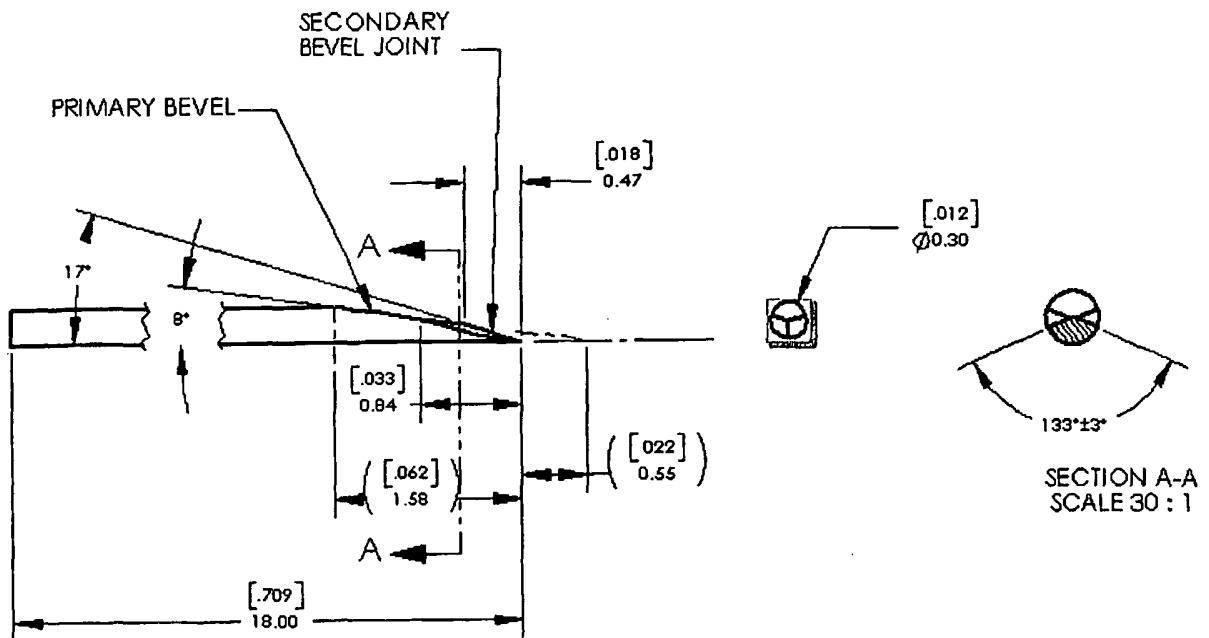

Figure 23B



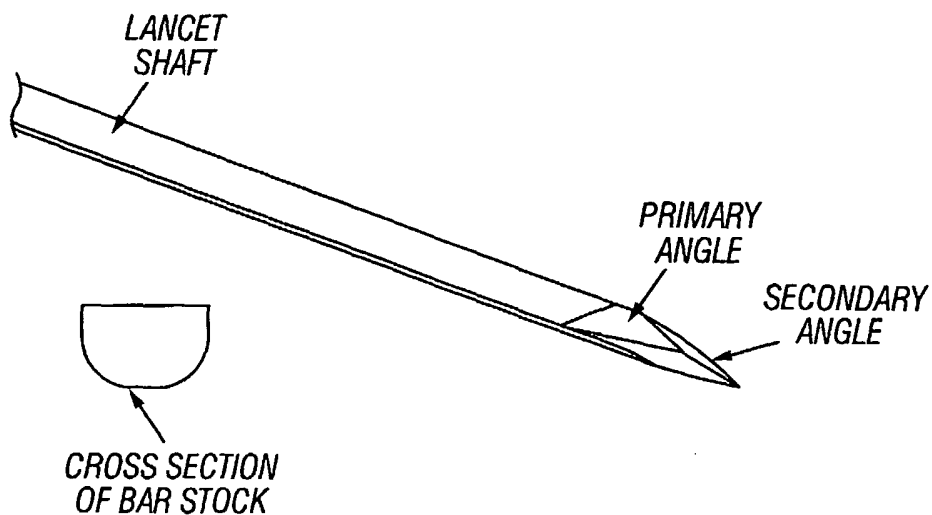

FIG. 24

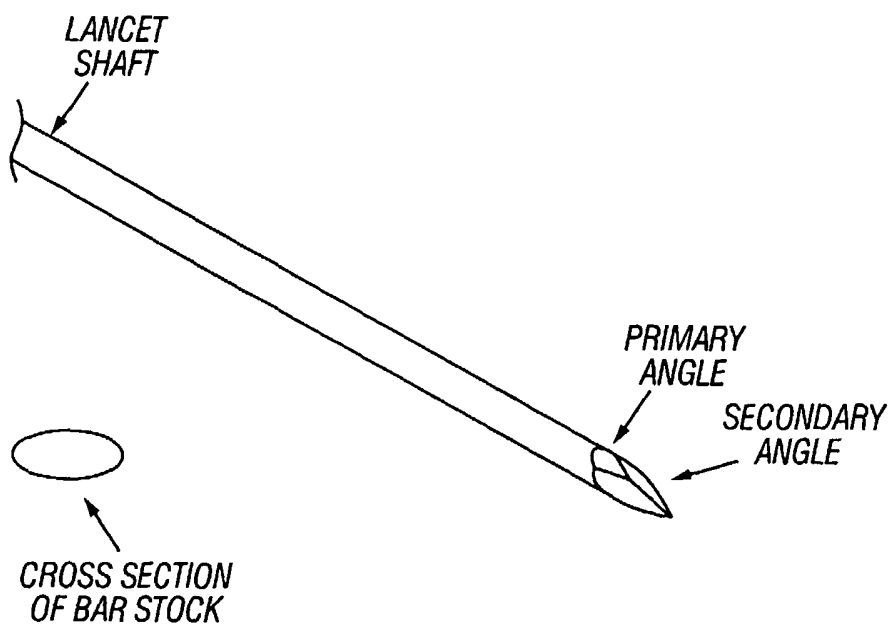

FIG. 25

10/21

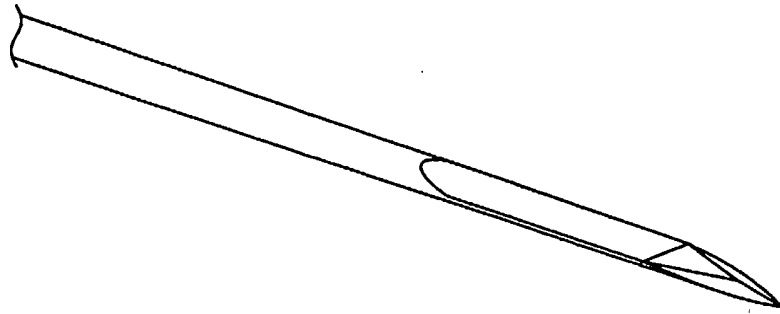

FIG. 26

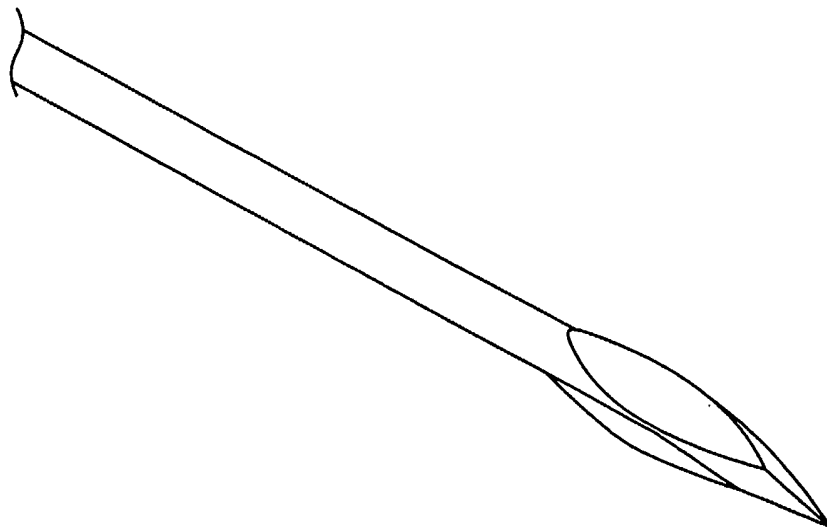

FIG. 27

11/21

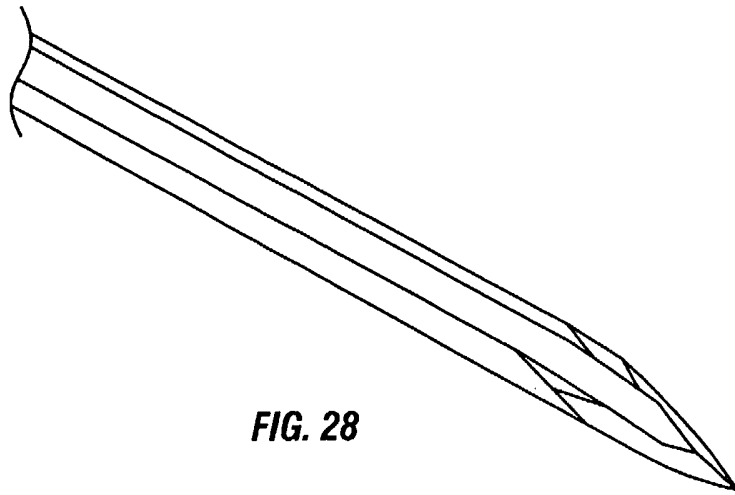

FIG. 28

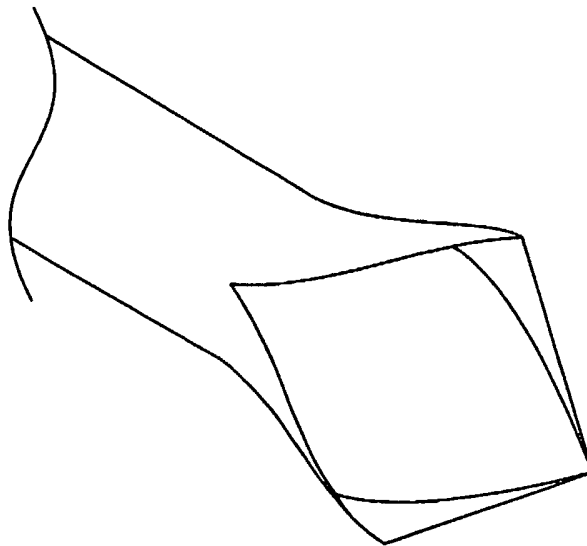

FIG. 29

LANCET TYPE	PRIMARY ANGLE (°)	BEVEL JOINT ANGLE (°)	SIDE FACET ANGLE (°)	LANCET LENGTH (mm)	LANCET DIAMETER (mm)	BEVEL JOINT LENGTH (C) (mm)	SIDE FACET LENGTH (B) (mm)	PRIMARY FACET LENGTH (A) (mm)
BD UF II	8.5416	16.6356	117.5551	14.8500	0.3036	0.4078	0.9261	1.58
BD UF III	9.42	19.03	113.85	14.7	0.202	0.22	0.54	1.22
HART (BD ANALOGUE DEVELOPED AT AGILENT)	6.4973	20.2989	110.7214	14.7059	0.3043	0.4985	0.8957	1.52
B I	6.8559	15.4851	115.3145	14.7000	0.3145	0.2188	0.6322	2.24
B II	11.4	20.9	106	N/A	0.232	0.234	0.441	0.94
B III (KEEP ANGLES, GRIND ON 0.200 DIAMETER)	7	16	133	N/A	0.200	0.27	0.53	1.27
B IV (KEEP LENGTHS THE SAME, RESULTING ANGLE?)	8	16	128	N/A	0.200	0.22	0.54	1.22

FIG. 30

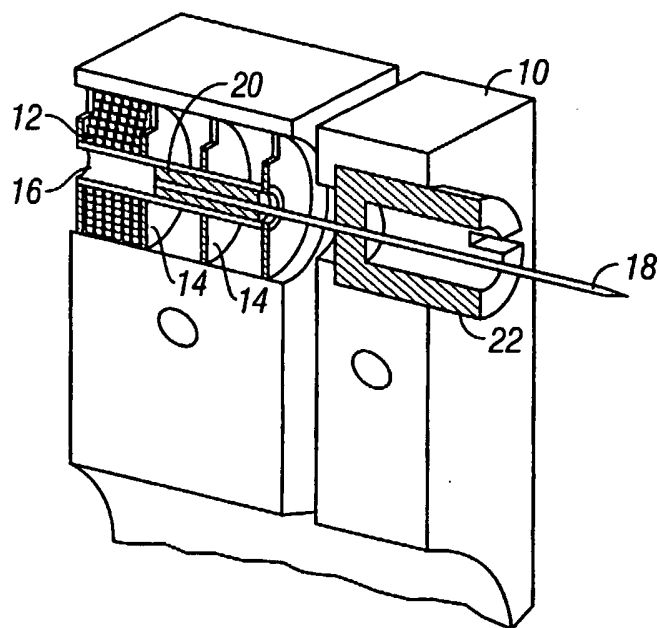

FIG. 31

14/21

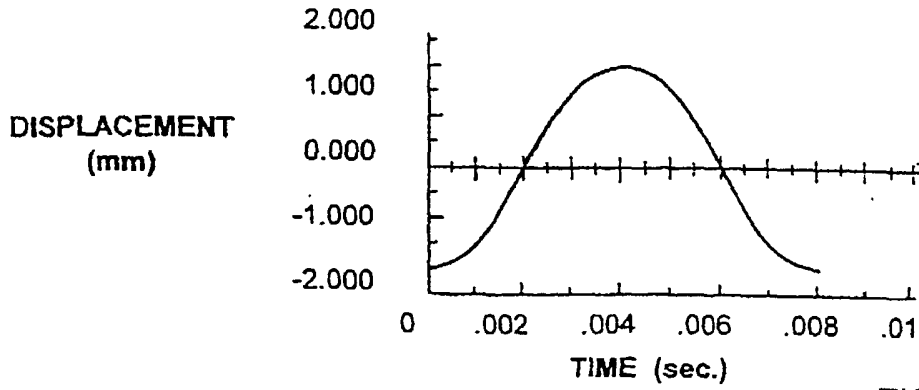

FIG. 32A

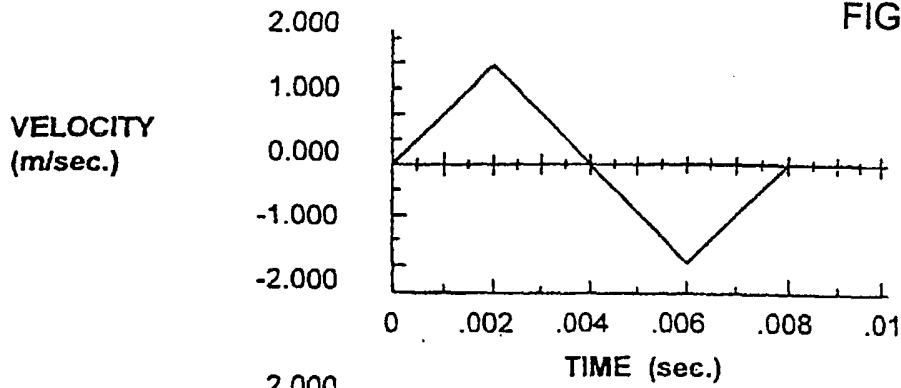

FIG. 32B

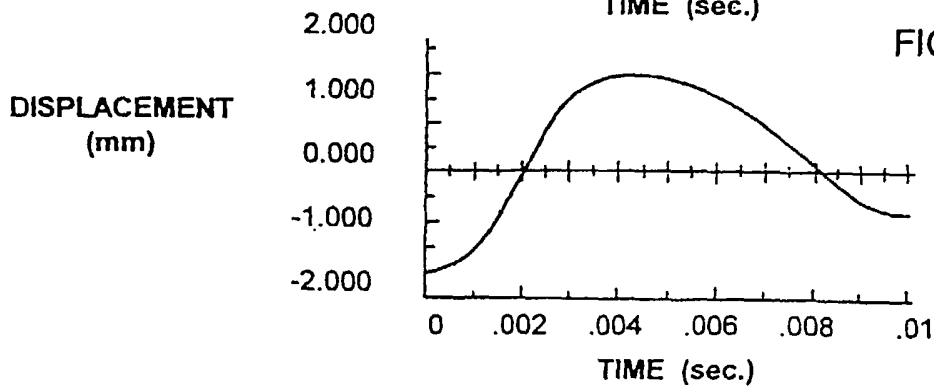

FIG. 32C

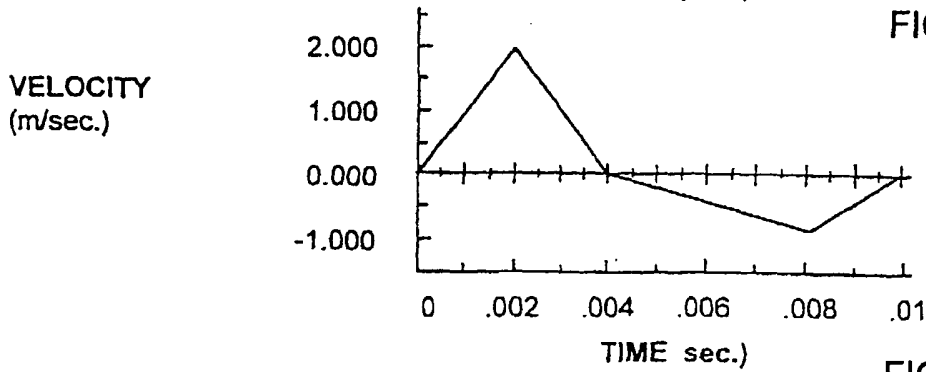

FIG. 32D

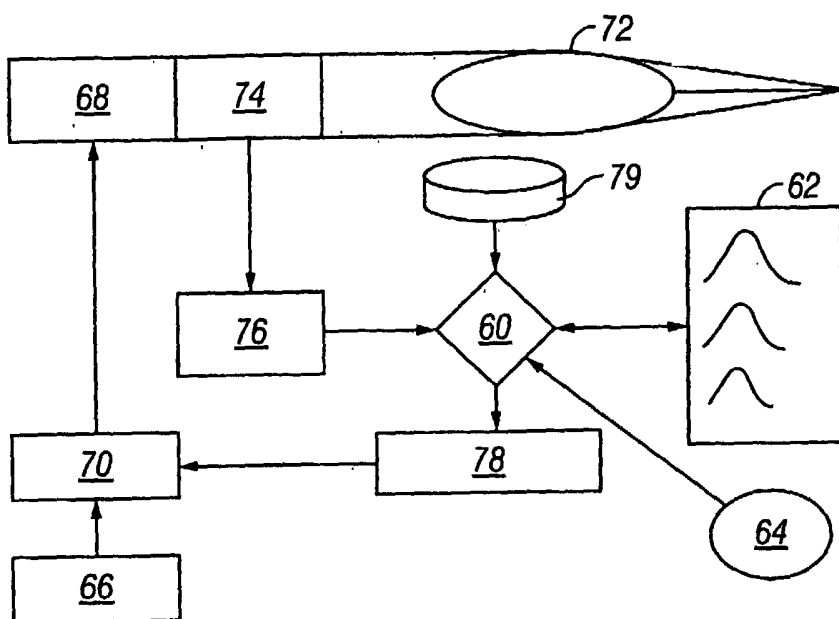

FIG. 33

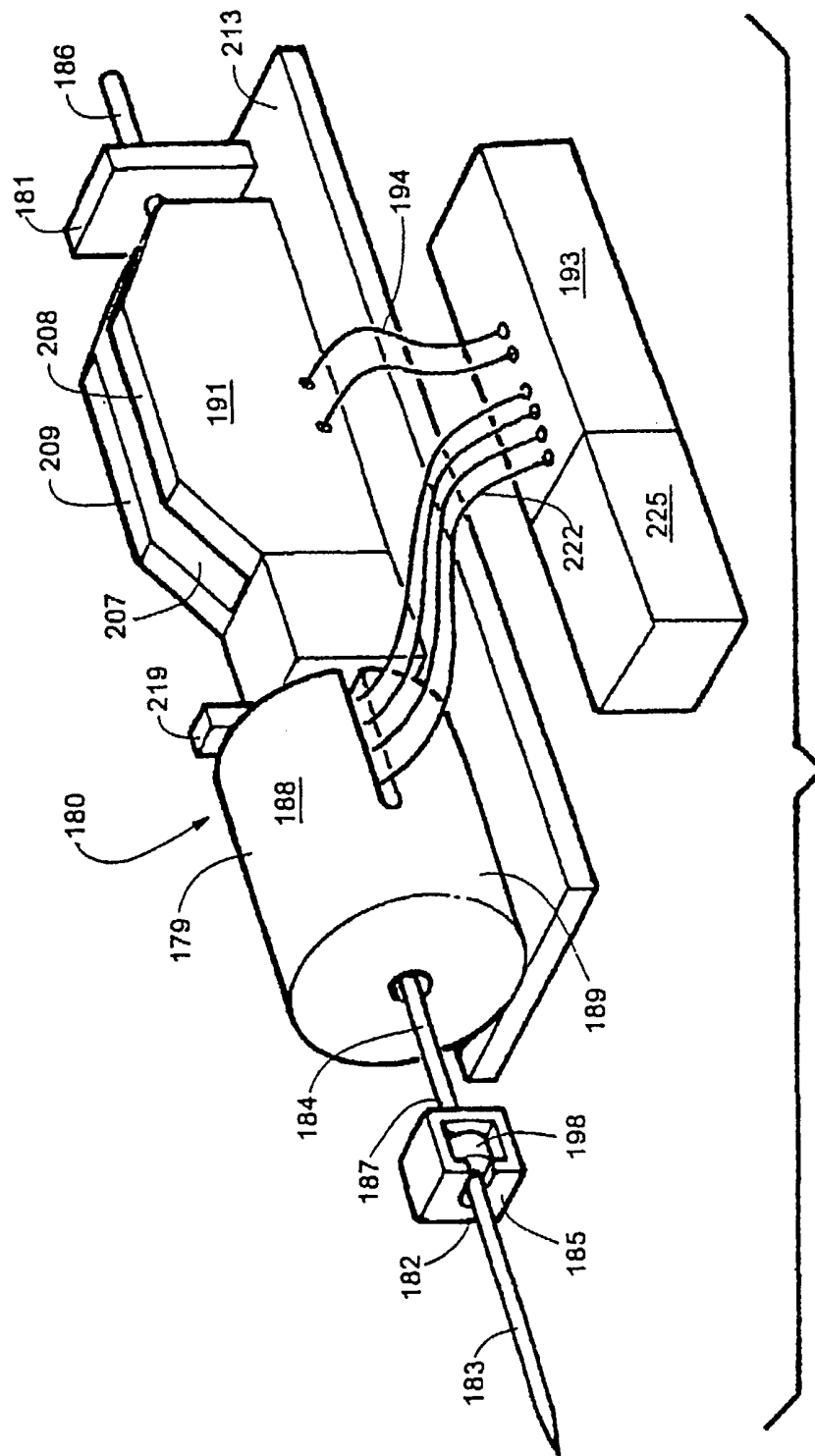

FIG. 34

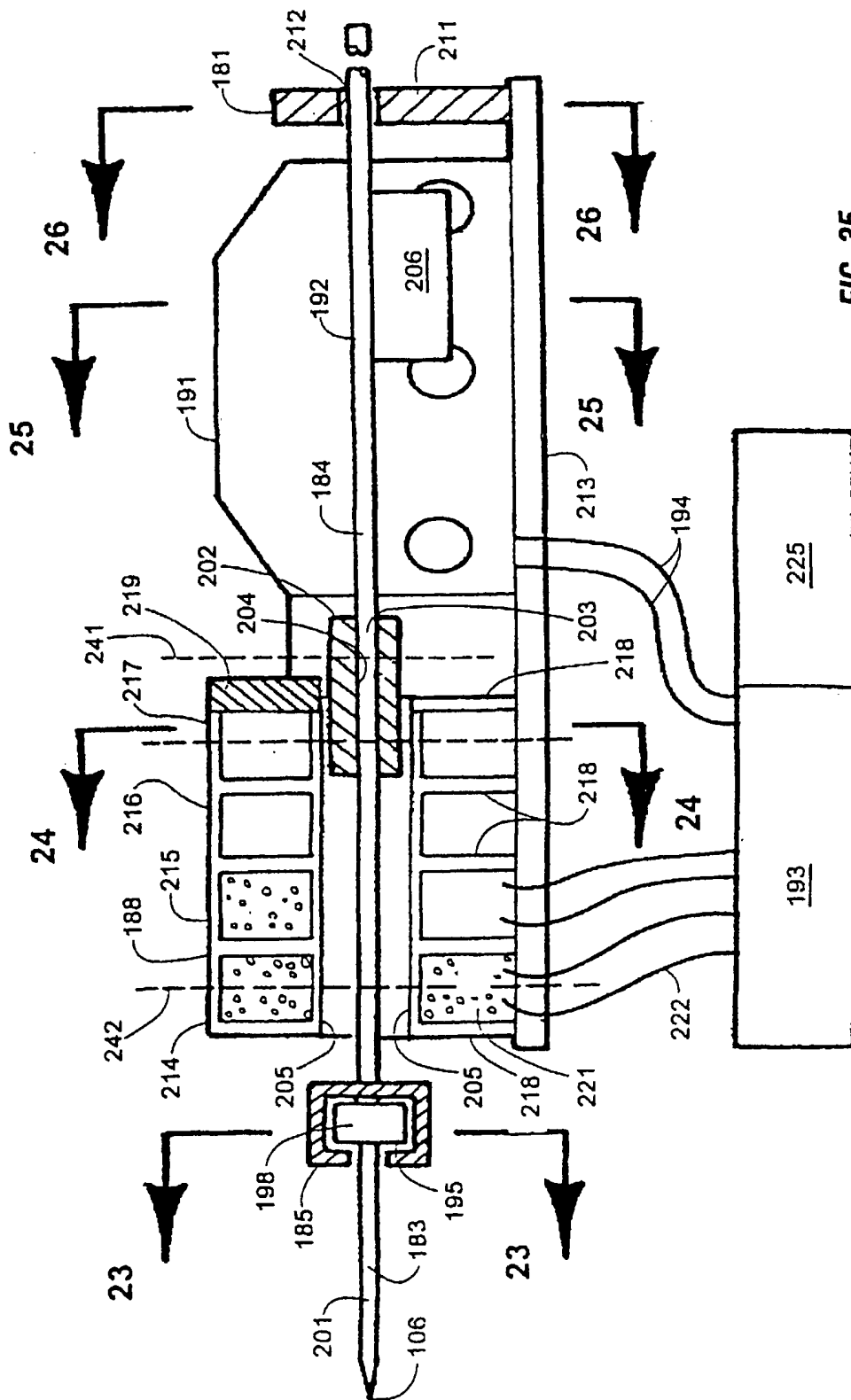

FIG. 35

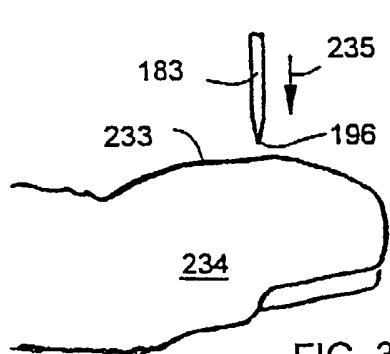

FIG. 36A

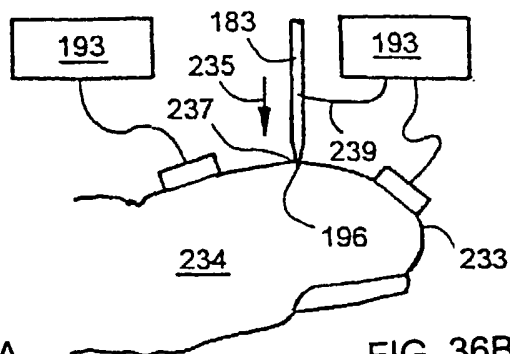

FIG. 36B

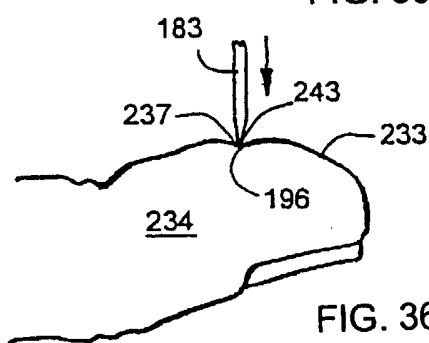

FIG. 36C

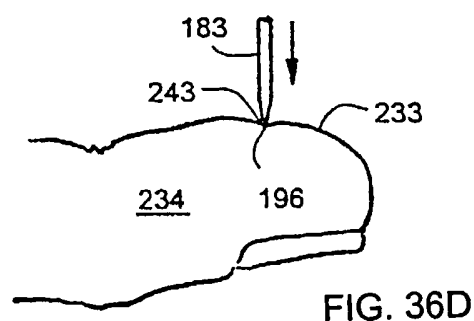

FIG. 36D

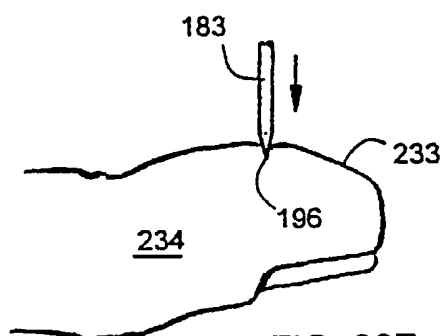

FIG. 36E

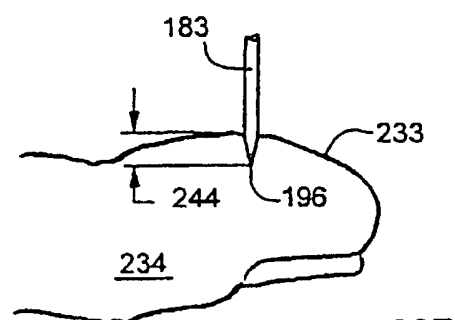

FIG. 36F

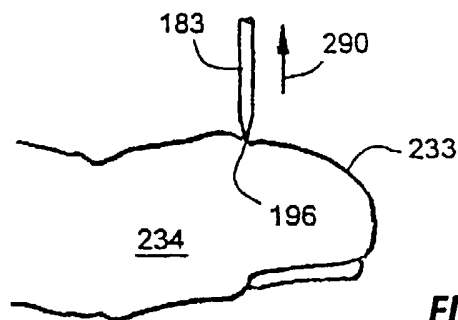

FIG. 36

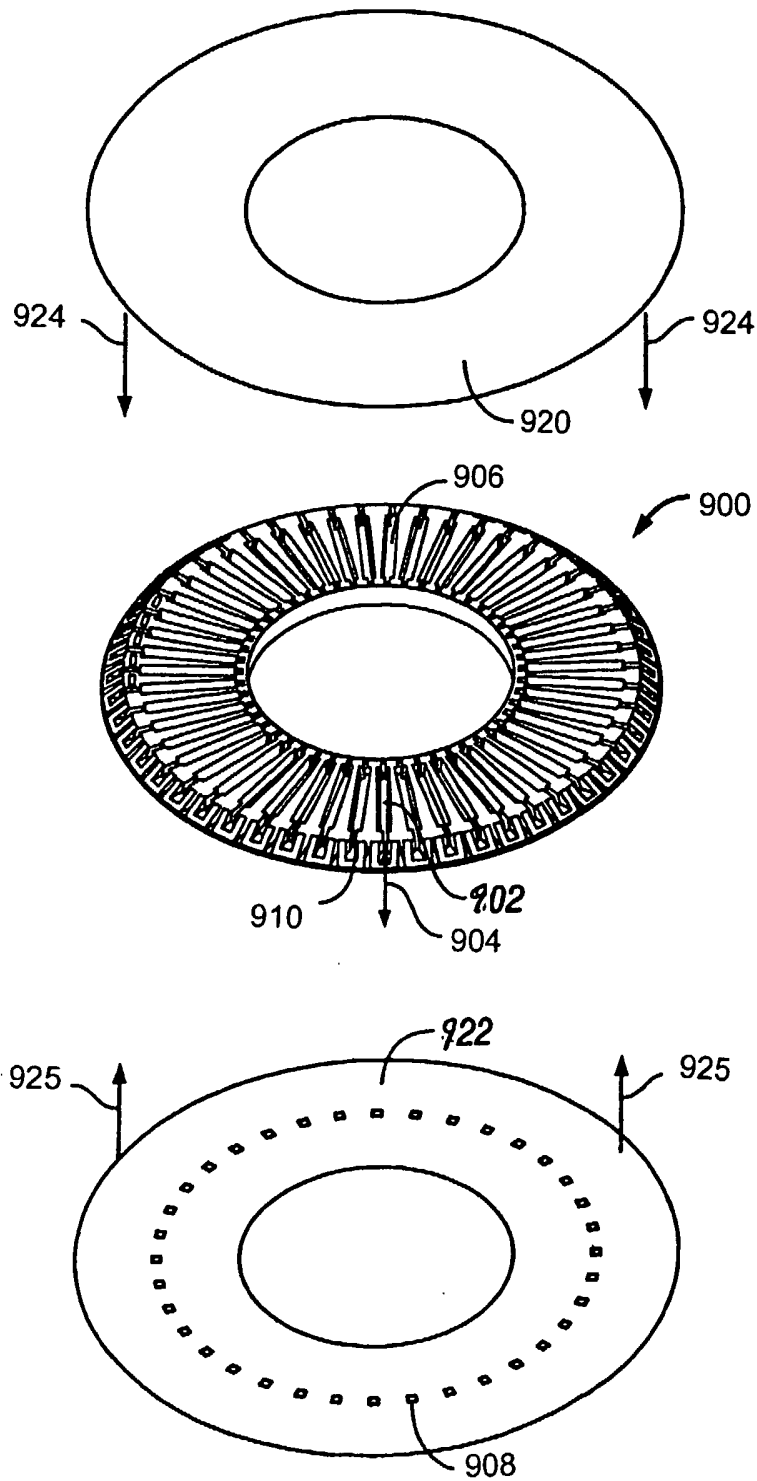

FIG. 37

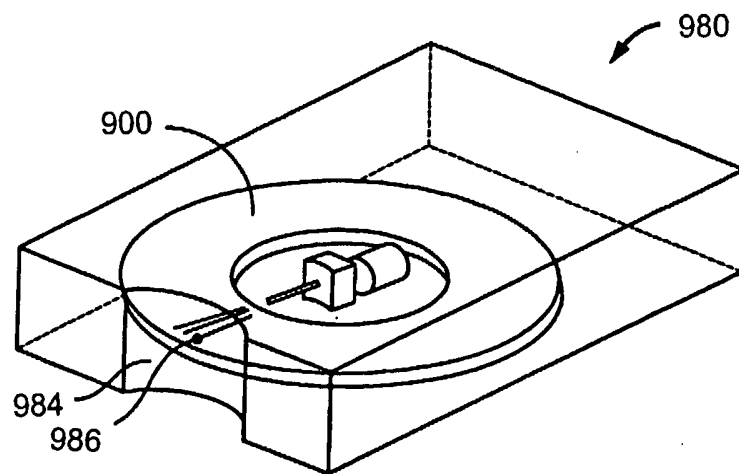

FIG. 38

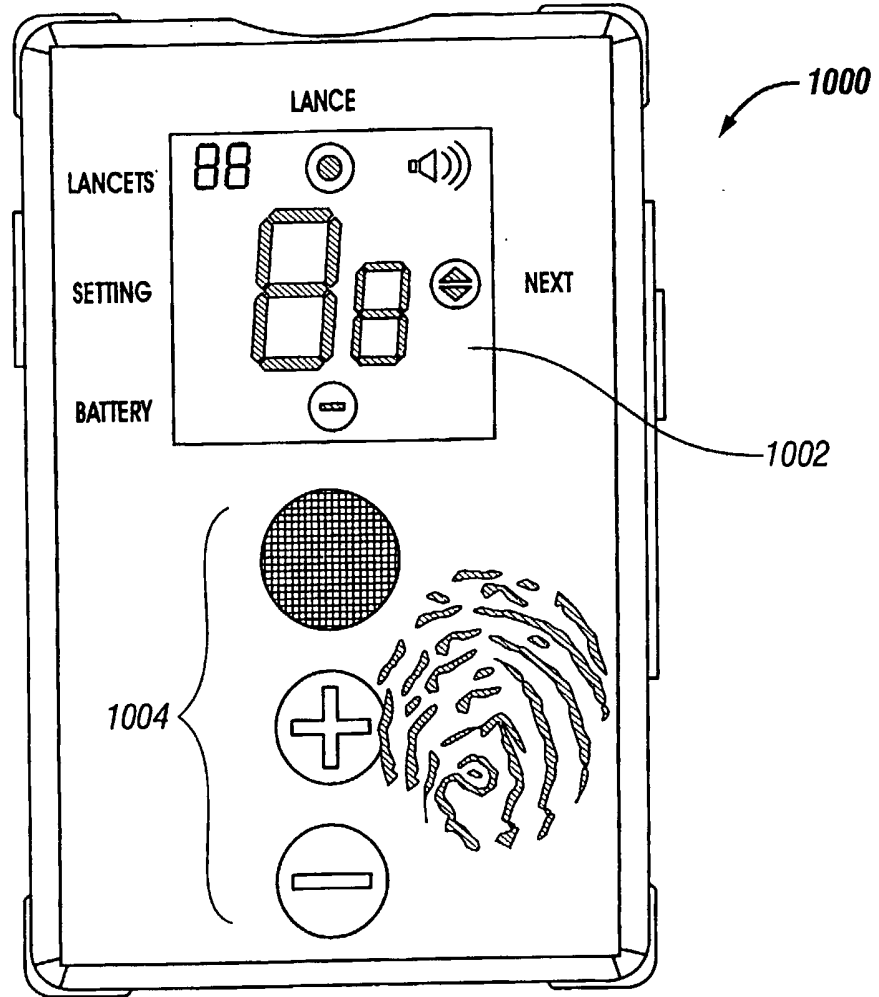

FIG. 39

INTERNATIONAL SEARCH REPORT

International application No.

PCT/US04/18705

<p>A. CLASSIFICATION OF SUBJECT MATTER IPC(7) : A61B 17/14 US CL : 606/181 According to International Patent Classification (IPC) or to both national classification and IPC</p>												
<p>B. FIELDS SEARCHED Minimum documentation searched (classification system followed by classification symbols) U.S. : 606/181,182; 600/583</p> <p>Documentation searched other than minimum documentation to the extent that such documents are included in the fields searched</p> <p>Electronic data base consulted during the international search (name of data base and, where practicable, search terms used)</p>												
<p>C. DOCUMENTS CONSIDERED TO BE RELEVANT</p> <table border="1"> <thead> <tr> <th>Category *</th> <th>Citation of document, with indication, where appropriate, of the relevant passages</th> <th>Relevant to claim No.</th> </tr> </thead> <tbody> <tr> <td>X</td> <td>US 5,782,852 A (Foggia et al) 21 July 1998, See entire document.</td> <td>1-37</td> </tr> </tbody> </table>			Category *	Citation of document, with indication, where appropriate, of the relevant passages	Relevant to claim No.	X	US 5,782,852 A (Foggia et al) 21 July 1998, See entire document.	1-37				
Category *	Citation of document, with indication, where appropriate, of the relevant passages	Relevant to claim No.										
X	US 5,782,852 A (Foggia et al) 21 July 1998, See entire document.	1-37										
<p><input type="checkbox"/> Further documents are listed in the continuation of Box C. <input type="checkbox"/> See patent family annex.</p>												
<p>* Special categories of cited documents:</p> <table border="0"> <tr> <td>"A" document defining the general state of the art which is not considered to be of particular relevance</td> <td>"T" later document published after the international filing date or priority date and not in conflict with the application but cited to understand the principle or theory underlying the invention</td> </tr> <tr> <td>"E" earlier application or patent published on or after the international filing date</td> <td>"X" document of particular relevance; the claimed invention cannot be considered novel or cannot be considered to involve an inventive step when the document is taken alone</td> </tr> <tr> <td>"L" document which may throw doubts on priority claim(s) or which is cited to establish the publication date of another citation or other special reason (as specified)</td> <td>"Y" document of particular relevance; the claimed invention cannot be considered to involve an inventive step when the document is combined with one or more other such documents, such combination being obvious to a person skilled in the art</td> </tr> <tr> <td>"O" document referring to an oral disclosure, use, exhibition or other means</td> <td>"&" document member of the same patent family</td> </tr> <tr> <td>"P" document published prior to the international filing date but later than the priority date claimed</td> <td></td> </tr> </table>			"A" document defining the general state of the art which is not considered to be of particular relevance	"T" later document published after the international filing date or priority date and not in conflict with the application but cited to understand the principle or theory underlying the invention	"E" earlier application or patent published on or after the international filing date	"X" document of particular relevance; the claimed invention cannot be considered novel or cannot be considered to involve an inventive step when the document is taken alone	"L" document which may throw doubts on priority claim(s) or which is cited to establish the publication date of another citation or other special reason (as specified)	"Y" document of particular relevance; the claimed invention cannot be considered to involve an inventive step when the document is combined with one or more other such documents, such combination being obvious to a person skilled in the art	"O" document referring to an oral disclosure, use, exhibition or other means	"&" document member of the same patent family	"P" document published prior to the international filing date but later than the priority date claimed	
"A" document defining the general state of the art which is not considered to be of particular relevance	"T" later document published after the international filing date or priority date and not in conflict with the application but cited to understand the principle or theory underlying the invention											
"E" earlier application or patent published on or after the international filing date	"X" document of particular relevance; the claimed invention cannot be considered novel or cannot be considered to involve an inventive step when the document is taken alone											
"L" document which may throw doubts on priority claim(s) or which is cited to establish the publication date of another citation or other special reason (as specified)	"Y" document of particular relevance; the claimed invention cannot be considered to involve an inventive step when the document is combined with one or more other such documents, such combination being obvious to a person skilled in the art											
"O" document referring to an oral disclosure, use, exhibition or other means	"&" document member of the same patent family											
"P" document published prior to the international filing date but later than the priority date claimed												
<p>Date of the actual completion of the international search</p> <p>11 February 2005 (11.02.2005)</p>		<p>Date of mailing of the international search report</p> <p>04 MAR 2005</p>										
<p>Name and mailing address of the ISA/US</p> <p>Mail Stop PCT, Attn: ISA/US Commissioner for Patents P.O. Box 1450 Alexandria, Virginia 22313-1450 Facsimile No. (703) 305-3230</p>		<p>Authorized officer</p> <p>Victor Nguyen</p> <p>Telephone No. (703) 308-0858</p>										