



(43) International Publication Date
7 November 2013 (07.11.2013)

- (51) International Patent Classification:
G01P 3/487 (2006.01)
- (21) International Application Number:
PCT/US2013/038612
- (22) International Filing Date:
29 April 2013 (29.04.2013)
- (25) Filing Language:
English
- (26) Publication Language:
English
- (30) Priority Data:
61/640,108 30 April 2012 (30.04.2012) US
61/783,202 14 March 2013 (14.03.2013) US

ME, MG, MK, MN, MW, MX, MY, MZ, NA, NG, NI, NO, NZ, OM, PA, PE, PG, PH, PL, PT, QA, RO, RS, RU, RW, SC, SD, SE, SG, SK, SL, SM, ST, SV, SY, TH, TJ, TM, TN, TR, TT, TZ, UA, UG, US, UZ, VC, VN, ZA, ZM, ZW.

(84) Designated States (unless otherwise indicated, for every kind of regional protection available): ARIPO (BW, GH, GM, KE, LR, LS, MW, MZ, NA, RW, SD, SL, SZ, TZ, UG, ZM, ZW), Eurasian (AM, AZ, BY, KG, KZ, RU, TJ, TM), European (AL, AT, BE, BG, CH, CY, CZ, DE, DK, EE, ES, FI, FR, GB, GR, HR, HU, IE, IS, IT, LT, LU, LV, MC, MK, MT, NL, NO, PL, PT, RO, RS, SE, SI, SK, SM, TR), OAPI (BF, BJ, CF, CG, CI, CM, GA, GN, GQ, GW, ML, MR, NE, SN, TD, TG).

- (72) Inventor; and
- (71) Applicant : PENNISI, Terry [US/US]; 105 Colby Road, Oak Ridge, Tennessee 37830 (US).
- (74) Agent: KULAGA, Thomas; PO Box 30034, Knoxville, Tennessee 37930 (US).

Declarations under Rule 4.17:

- as to the identity of the inventor (Rule 4.17(i))
- as to applicant's entitlement to apply for and be granted a patent (Rule 4.17(ii))
- as to the applicant's entitlement to claim the priority of the earlier application (Rule 4.17(iii))
- of inventorship (Rule 4.17(iv))

Published:

- with international search report (Art. 21(3))

(81) Designated States (unless otherwise indicated, for every kind of national protection available): AE, AG, AL, AM, AO, AT, AU, AZ, BA, BB, BG, BH, BN, BR, BW, BY, BZ, CA, CH, CL, CN, CO, CR, CU, CZ, DE, DK, DM, DO, DZ, EC, EE, EG, ES, FI, GB, GD, GE, GH, GM, GT, HN, HR, HU, ID, IL, IN, IS, JP, KE, KG, KM, KN, KP, KR, KZ, LA, LC, LK, LR, LS, LT, LU, LY, MA, MD,

(54) Title: POWER HARVESTING WIRELESS TRANSMITTER

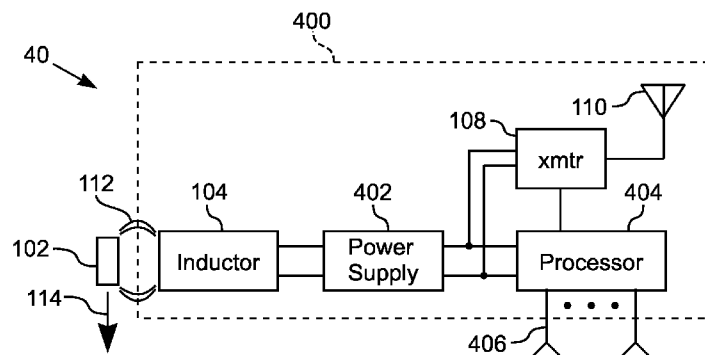
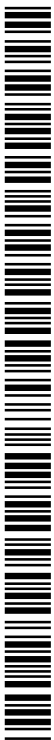

Fig. 4

(57) Abstract: Apparatus for a wireless transmitter (40). The wireless transmitter (40) includes a magnet (102), an inductor (104) a power supply (402), a processor (404), and a transmitter (108) with an antenna (110). The magnet (102) interacting with the inductor (104) provides a sole source of power sufficient to power the transmitter (108). The inductor (104) is connected to the power supply (402). The power supply (402) includes a voltage multiplier (522), a storage unit (524), and, in one embodiment, a voltage regulator (526). The processor (404) includes at least one input (406) connected to one or more local switches, sensors, and instruments. The processor (404) outputs an identifier and data corresponding to the inputs (406) to the transmitter (108), which sends a wireless signal. Another embodiment of a wireless transmitter (40) includes a magnet (102), an inductor (104), a delay circuit (106), and a transmitter (108). The inductor (104) generates both power and a trigger signal for the transmitter (108).



TITLE

Power harvesting wireless transmitter

CROSS-REFERENCE TO RELATED APPLICATIONS

[0001] This application claims the benefit of U.S. Provisional Application No. 61/640,108, filed April 30, 2013, and U.S. Provisional Application No. 61/783,202, filed March 14, 2013.

BACKGROUND

[0002] This invention pertains to a wireless monitoring system with a self-powered transmitter. More particularly, this invention pertains to a wireless transmitter with a power harvesting circuit supplying power to a processor and a transmitter.

[0003] 2. Description of the Related Art

[0004] Rotating and moving machines are in widespread use for many industrial processes. These processes often require local sensors and instruments to monitor various parameters with the sensors and instruments wired to remote control and monitoring panels. Traditionally, a sensor or instrument is mounted on or next to the machine and wiring is needed to provide power to the sensor and/or to send a signal from the sensor to a remotely mounted monitor. In an automobile, wiring from a sensor measuring engine speed and/or tire rotational speed adds complexity and cost during manufacturing and maintenance because of the constraints inherent in a vehicle. In industrial applications, wiring from sensors on rotating, reciprocating, and linear machines adds complexity and costs because of the environment and distance between such equipment and the remote monitoring equipment.

[0005] Also, with rotating machines, rotational speed is often desired to be measured. Rotational speed provides information on how fast the machine is rotating, and depending upon the configuration, on the speed of a downstream component. With reciprocating or linear machines, such as piston operated machines and conveyors, the time between oscillations or the time the machine takes to move from one point to another provides useful information.

[0006] Traditional sensors and instruments need a power source, either independent and connected to the device or supplied through the signal circuit. Independent power supplies from external sources and from batteries create reliability problems for the instrumentation system because the instrumentation power source is typically independent of the power source for the machine being monitored.

BRIEF SUMMARY

[0007] According to one embodiment of the present invention, a power harvesting wireless transmitter system is provided. The power harvesting transmitter is a wireless monitoring system that has no need for external wiring for a power source or for sending the signal from the sensor to a remote location. In this way the wireless transmitter is self-contained with a reliable power source and without external wiring for power and connectivity.

[0008] The power harvesting wireless transmitter system includes a magnet and a multi-sensor transmitter that is responsive to the magnet. The multi-sensor transmitter includes an inductor, a power supply, a processor, and a transmitter with an antenna. The magnet interacting with the inductor generates sufficient power to energize the processor and transmitter. The magnet interacting with the inductor is the sole source of power for the wireless transmitter system.

[0009] In one embodiment, the magnet moving relative to an inductor coil induces a current/voltage spike in the inductor. The inductor coil is connected to a power supply that includes a voltage multiplier, a storage circuit, and a voltage regulating circuit. The voltage multiplier harvests the power from the magnetic field interacting with the inductor. The output of the voltage multiplier is connected to a storage circuit, which, in one embodiment, is a capacitor. The output of the storage circuit is connected to a voltage regulating circuit. In one embodiment, the voltage regulating circuit are series connected light emitting diodes (LEDs).

[0010] The power supply provides power to the processor and transmitter. The processor has one or more inputs. The inputs are connected to switches, sensors, and instruments. The processor monitors the inputs and provides an

output of an identifier and data that is provided to the transmitter, which transmits the identifier and data via a wireless signal. The identifier is a code that identifies the transmitter system. When multiple transmitter systems are used, it is desirable for the receiver to distinguish between the transmitter systems. The data sent with the identifier represents the parameters monitored by the processor inputs. The transmitted wireless signal is sensed by a receiver that is responsive to the wireless signal.

[0011] In some cases multiple wireless transmitters are deployed. Each one of the wireless transmitters monitors a different set of parameters or a different machine. For example, parallel processes may each have a rotating machine with a corresponding wireless transmitter. In one embodiment, each one of the wireless transmitters transmits at a different frequency or channel or with a different type of modulation. In this way, multiple parameters are monitored. In another embodiment, each wireless transmitter has a unique identifier that is transmitted with the monitored data. To avoid collisions the rate of transmission varies between the wireless transmitters, such as each transmitter using a different clock rate or schedule of transmission.

[0012] According to another embodiment of the present invention, a single sensor burst transmitter system is provided. The single sensor burst transmitter system is a wireless monitoring system that has no need for external wiring for a power source or sending the signal from the sensor. In this way the wireless monitoring system is self-contained without external wiring.

[0013] The single sensor burst transmitter system includes a magnet and a burst transmitter that is responsive to the magnet. The burst transmitter includes an inductor, a delay circuit, and a transmitter with an antenna. The magnet interacting with the inductor generates sufficient power to transmit a signal corresponding to the time that the magnet interacts with the inductor. Precise timing is insured by the inductor connected to the trigger input of the transmitter unit and the delay circuit adding a short delay of the signal applied to the trigger input with the delayed signal connected to the supply voltage connection of the transmitter. The transmitter transmits a signal upon being energized because the trigger is already at its trigger voltage when the transmitter unit is energized with enough power to transmit. The transmitter outputs a pulse to an antenna every time the magnet engages the coil. In this

way, the single sensor burst transmitter system is self-powered and has a minimum number of components.

[0014] In one embodiment, the magnet passing by an inductor coil induces a current/voltage spike in the inductor. One end of the coil is electrically connected to a reference, common, or ground on the transmitter and to one end of an RC (resistance-capacitance) network that is also connected to the supply voltage connection of the transmitter. The other end of the coil is connected to the trigger input on the transmitter. The transmitter is powered and triggered by the magnet interacting with the coil, thereby transmitting a pulse from an antenna attached to the transmitter. In various embodiments, one or more magnets are attached to a moving part of the machine.

[0015] In various embodiments, the single sensor burst transmitter system senses a parameter of a vehicle or machine, such as motor or engine revolutions per minute (RPM) or the vehicle speed, and transmits data representing that parameter. In one such embodiment, the system includes a magnet positioned on a rotating or moving component of a vehicle, such as a shaft, fan belt pulley, flywheel, or drive shaft. In another embodiment, the system senses a parameter of a machine, such as a pump, a motor, or conveyor. Examples of the monitored parameter include rotational speed, rate of reciprocation, belt speed, or other cyclical motion that positions one or more magnets spatially at a fixed location with a frequency that is measured.

[0016] The magnet is magnetically coupled to an inductor when the magnet moves past the inductor. The magnetic coupling induces a voltage/current spike in the inductor. The inductor is connected between the reference or common and the trigger of the transmitter. The inductor is also connected to a delay, or resistor-capacitor tank circuit, that is connected to the supply voltage connection of a transmitter. The inductor supplies a trigger signal to the transmitter before the transmitter receives sufficient power from the inductor to turn on. The voltage spike from the inductor interacting with the magnet causes the transmitter to send a wireless pulse from an antenna connected to the transmitter. The transmitted pulses are sensed by a receiver that is responsive to the wireless signal.

[0017] In one embodiment, multiple single sensor burst transmitter systems are employed. Each one of the burst transmitter systems monitors a different parameter or different machine. Each one of the burst transmitter systems transmits at a different frequency or channel or with a different type of modulation. In this way, multiple parameters are monitored.

BRIEF DESCRIPTION OF THE SEVERAL VIEWS OF THE DRAWINGS

[0018] The above-mentioned features will become more clearly understood from the following detailed description read together with the drawings in which:

[0019] FIG. 1 is a functional block diagram of one embodiment of a single sensor burst transmitter system.

[0020] FIG. 2 is a schematic diagram of one embodiment of a single sensor burst transmitter system.

[0021] FIG. 3a is a diagram showing the trigger signal applied to the transmitter unit over time.

[0022] FIG. 3b is a diagram showing the Vcc voltage applied to the transmitter unit over time.

[0023] FIG. 3c is a diagram showing the pulse signal sent to the antenna over time.

[0024] FIG. 4 is a functional block diagram of one embodiment of a multi-sensor transmitter system.

[0025] FIG. 5 is a schematic diagram of one embodiment of a power supply.

[0026] FIG. 6 is a functional block diagram of one embodiment of a wireless tachometer system.

[0027] FIG. 7 is a schematic diagram for one embodiment of a signal conditioner.

[0028] FIG. 8 is a schematic diagram for another embodiment of a signal conditioner.

DETAILED DESCRIPTION

[0029] Apparatus for a single sensor burst transmitter system **10** and a multi-sensor transmitter system **40** are disclosed. The single sensor burst transmitter system **10** senses and transmits a parameter associated with a machine or device that has cyclic or reciprocating movement. The multi-sensor transmitter system **40** senses and transmits data for one or more parameters while being powered by a machine or device that has periodic, cyclic, or reciprocating movement.

[0030] FIG. **1** illustrates a functional block diagram of one embodiment of a single sensor burst transmitter system **10**. The system **10** includes a magnet **102** and a burst transmitter **100**. The magnet **102**, in one embodiment, is attached to a moving object such that the magnet **102** periodically moves past the burst transmitter **100**. The burst transmitter **100** interacts with the magnet **102** and transmits a pulse **306** each time the magnet **102** passes by the burst transmitter **100**.

[0031] The burst transmitter **100** includes an inductor **104**, a delay **106**, and a transmitter **108** that is connected to an antenna **110**. The magnetic field **112** of the magnet **102** engages the inductor **104** when the magnet **102** moves past the inductor **104**. The magnetic field **112** of the magnet **102** interacts with the inductor **104** and induces a pulse **302** in the inductor **104**.

[0032] The magnet **102** is secured to a part of a machine that moves in at least one direction **114** relative to the inductor **104** in the burst transmitter **100**. The magnet **102**, through the magnetic field interaction with the burst transmitter **100**, provides the energy that powers the burst transmitter **100**. Also, the magnet **102** triggers the burst transmitter **100** to transmit the signal **306** when the magnet **102** is proximate the inductor **104**. Although the illustrated embodiment depicts the magnet **102** as moving in direction **114**, it is the relative motion between the magnet **102** and the inductor **104** that is relevant. For example, in another embodiment, the burst transmitter **100** is attached to the moving component and the magnet **102** is stationary.

[0033] The magnet **102** is dimensioned relative to the moving part of the machine such that the magnetic field **112** is substantially a point source that engages the inductor **104** for a shorter duration than the duration when the

magnetic field **112** does not engage the inductor **104**. That is, the interaction of the magnetic field **112** with the inductor **104** occurs briefly compared to the long dwell time with no interaction by the magnetic field **112**. The interaction of the magnetic field **112** occurs during an interaction interval, which can be expressed in units of time or angular displacement. The dwell interval refers to the time or angular displacement where the magnetic field **112** does not interact with the inductor **104**. For those embodiments where a magnet **102** is attached to a moving component of a machine, the magnet **102** will be substantially smaller than the moving component in order to minimize the mass added to the moving component and to minimize any unbalancing effect from the addition of the magnet **102**. Typically, the ratio of the interaction interval to the dwell interval will be about 1:10 or less. For example, in one embodiment, the magnet **102** is cylindrical and less than 1/2 inch in diameter. The magnet **102** is attached to a rotating pulley that is six inches in diameter. In this example the interaction interval is approximately 10 degrees or less and the dwell interval is approximately 350 degrees or more, which results in the ratio of the interaction interval to the dwell interval of 10:350.

[0034] The magnet **102** is attached to a moving component that moves in a cyclical or repetitive manner such that the magnet **102** repeatedly moves proximate the inductor **104** at an interval that corresponds to some variable to be measured, such as revolutions per minute (RPM). For example, in one embodiment, the magnet **102** is attached to a shaft of a pump or motor. The magnet **102** moves in direction **114** as the shaft rotates. The rate of interactions of a single magnet **102** on the shaft with the inductor **104** provides data on the rotational speed of the shaft. One interaction between the magnet **102** and inductor **104** corresponds to one revolution of the shaft.

[0035] For slower moving devices, multiple magnets **102** are spaced at regular intervals and an appropriate scaling factor is applied to the sensed rate of interactions to determine the rate of movement. For example, a plurality of magnets **102** are attached to a conveyor belt at regular intervals to measure the speed of the conveyor belt. Each time a magnet **102** moves proximate the inductor **104** the burst transmitter **100** transmits a pulse **306**. Either the time difference between pulses **306** or the number of pulses **306** per unit of time are used to determine the speed of the conveyor belt.

[0036] The inductor **104** is responsive to the magnetic field **112** of the magnet **102**. The leads of the inductor **104** are connected to the transmitter **108**. The interaction of the magnetic field **112** of the magnet **102** with the inductor **104** causes the inductor **104** to generate a pulse **302** that sets the trigger **Tr** of the transmitter **108**.

[0037] The delay **106** is connected between the reference or ground **Ref** of the transmitter **108** and the supply voltage **Vcc** connection of the transmitter **108**. The delay **106** adds a short time delay to the pulse **302** from the inductor **104**.

[0038] The transmitter **108** is a device that transmits a wireless signal through an antenna **110**. In one embodiment, the transmitter unit **108** causes a wireless radio frequency (RF) signal to be sent from the antenna **110**. The transmitter unit **108** is both powered and triggered by the magnetic field **112** of the magnet **102** interacting with the inductor **104**. When multiple single sensor burst transmitter systems **10** are used within range of a single receiver, the transmitters **108** are configured to minimize or reduce interference. For example, in one embodiment, each transmitter **108** operates at a specific frequency or channel different from other transmitters **108**.

[0039] FIG. 2 illustrates a schematic diagram of one embodiment of a single sensor burst transmitter system **10**. The illustrated embodiment of the transmitter system **10** includes a magnet **102** and a burst transmitter **100**. The burst transmitter **100** includes an inductor **104**, a delay circuit **106**, a transmitter **108**, and an antenna **110**.

[0040] In one embodiment, the magnet **102** is secured to a moving part of a machine. The magnet **102** moves in a direction **114** relative to the inductor **104**. Because the magnet **102** adds mass to the moving part, the magnet **102** in one embodiment is a rare earth magnet, which ensures the size is minimized and the magnetic field generated is as strong as possible relative to the size of the magnet **102**. In another embodiment, the burst transmitter **100** is secured to the moving part of the machine and the magnet **102** is stationary.

[0041] The inductor **104** is a coil that is responsive to the magnetic field **112** of the magnet **102**. In various embodiments, the inductor **104** is an air

wound coil or a cored inductor. The inductor **104** is oriented such that the magnetic field **112** passing through the inductor **104** generates sufficient power to drive the transmitter **108**.

[0042] The delay **106** includes an RC circuit with a resistor **202** and capacitor **204** connected in parallel. The RC circuit **106** is connected between the reference, common, or ground **Ref** of the transmitter **108** and the supply voltage **Vcc** connection of the transmitter **108**. The delay circuit **106** adds a short delay to the voltage generated by the inductor **104** and applies that delayed signal **304** to the supply voltage **Vcc** connection of the transmitter unit **108**. The values for the resistor **202** and the capacitor **204** in the RC circuit **106** are selected such that the voltage across the capacitor **204** falls below the minimum required Vcc voltage **312** within the period **324** between trigger pulses **304**. That is, the time to drain the capacitor **204** is less than the period **324** being measured.

[0043] The transmitter **108** is a low power device with a fast response time that is operable with the amount of power generated by the magnet **102** moving relative to the inductor **104**. The transmitter **108** has a trigger input **Tr** that causes the transmitter **108** to output a signal from the antenna output **ANT** to the antenna **110** when the trigger input **Tr** is at or above a trigger voltage **312**. In various embodiments, the antenna **110** is an external or built-in antenna operating at the frequency of the transmitter **108**.

[0044] In one example, the transmitter **108** is an amplitude modulated (AM) hybrid transmitter unit, such as the Model AM-RT4-315 sold by RF Solutions. The transmitter unit **108** is a complete, self-contained RF transmitter that supports a transmitted data rate up to about 4kHz. The transmitter unit **108** requires a supply voltage (Vcc) of between 2 and 14 volts dc with a typical supply current of 4 mA at 5 Vdc. The minimum input level is 2 volts dc with a maximum equal to Vcc. The transmitter unit **108** operates at a fixed frequency of 315 MHz with a range up to 70 meters. The transmitter unit **108** has four leads: supply voltage **Vcc**, reference or ground **Ref**, trigger input **Tr**, and output for an external antenna **Ant**. The transmitter unit **108** has an equivalent circuit capacitance of 1nF between the trigger input **Tr** and the supply voltage **Vcc** connections, and an equivalent circuit capacitance of 100pF between the ground **Ref** and the trigger input **Tr** connections and between the ground **Ref** and the supply voltage **Vcc** connections.

[0045] In such an example, the supply voltage **Vcc** signal **304** is delayed approximately 0.6 milliseconds relative to the signal **302** applied to the trigger input **Tr** of the transmitter unit **108**. Such a delay is sufficient to ensure that the transmitter unit **108** transmits a signal **306** as soon as the supply voltage **Vcc** signal **304** is at a level sufficient to power the transmitter unit **108**. That is, with the trigger input **Tr** at a voltage at or above the required trigger voltage **312**, the transmitter **108** outputs a signal as soon as the Vcc voltage reaches the minimum required Vcc voltage **314**. With the transmitter unit **108** in this example, the minimum trigger input **Tr** and the minimum supply voltage **Vcc** are the same, which is 2 volts. In the tested embodiment, the magnet **102** and inductor **104** combination produce a spike of 2.8 volts, which is sufficient to operate the transmitter unit **108**.

[0046] FIG. 2 illustrates a simplified schematic of one embodiment of a single sensor burst transmitter system **10**. The simplified schematic does not illustrate various connections that may be required to accommodate specific components selected, for example, the transmitter unit **108** may require a crystal or other frequency selection circuitry. An antenna tuning or matching circuit may also be needed depending upon the components selected. Those skilled in the art will recognize the need for such wiring and understand how to wire such a circuit, based on the components ultimately selected for use.

[0047] FIG. 3a illustrates a diagram showing the trigger signal **302** applied to the transmitter unit **108** over time **t**. FIG. 3b illustrates a diagram showing the Vcc voltage **304** applied to the transmitter unit **108** over time **t**. FIG. 3c illustrates a diagram showing the output pulse signal **306** sent to the antenna **110** over time **t**. The output pulse **306** is a signal at the frequency of the transmitter unit **306**, which is much greater than the frequency of magnet **102** - inductor **104** interactions. The output pulse **306** is shown as a square wave because of the magnitude of the frequency difference. The diagrams also illustrate the periodic nature of the signals that correspond to the rate of interaction between the magnet **102** and the inductor **104**. In the illustrated embodiment, the period **324** between spikes or pulses **302**, **304**, **306** is regular.

[0048] The inductor **104** generates a voltage spike **302** from the interaction of the magnetic field **112** of the magnet **102** as it moves by the inductor **104**. The inductor **104** is connected between the reference or ground

Ref and the trigger input **Tr** of the transmitter **108** such that the voltage at the trigger input **Tr** is positive relative to ground **Ref**. The trigger spike **302** has a maximum voltage that is equal to or greater than the minimum required trigger voltage **312** at the time **310** the output pulse **306** begins. The minimum required trigger voltage **312** is the voltage level required by the trigger input **Tr** of the transmitter **108** to send a signal.

[0049] The delay circuit **106** is connected between the reference or ground **Ref** and the supply voltage **Vcc** connections of the transmitter **108**. The RC circuit **106** adds a short delay to the voltage spike **302** from the inductor **104** such that the supply voltage **304** reaches a level **310** sufficient to power the transmitter **108** after the trigger input **Tr** has reached a sufficient level to trigger the transmitter **108** to send a pulse **306**. The minimum required Vcc level **314** is the voltage level required by the transmitter **108** to be energized and operable.

[0050] The Vcc voltage **304** enables the transmitter **108** to operate when the Vcc voltage **304** reaches the minimum required Vcc voltage **314** at time **310**. A first vertical line **310** shows the relationship between when the Vcc voltage **304** reaches the minimum required Vcc voltage **314** and the other signals **302**, **306**.

[0051] Referring to FIG. 3a, the trigger spike **302** has a voltage that is equal to or greater than the minimum required trigger voltage **312** at the time **310** the Vcc voltage **304** reaches the minimum required Vcc voltage **314**. Because these two conditions are met (trigger voltage **302** at or greater than minimum trigger voltage **312** and Vcc voltage **304** at or greater than minimum required Vcc voltage **314**), the transmitter unit **108** sends an output pulse **306** starting at time **310**.

[0052] The second vertical line **320** shows the relationship between when the trigger signal **302** falls below the minimum required trigger voltage **312** and the other signals **304**, **306**. The output pulse **306** ends at the time **320** when the trigger signal **302** falls below the minimum required trigger voltage **312** or the Vcc voltage **304** falls below the minimum required Vcc voltage **314**, whichever occurs first. In the illustrated diagrams, the output pulse **306** stop time **320** occurs when the trigger signal **302** falls below the minimum required trigger voltage **312**. The time width of the Vcc voltage signal **304** at the minimum required Vcc voltage **314**, minus the amount of time delay introduced by the RC

circuit **106**, determines the width of the output pulse **306**. that is, the width of the pulse **306** is the time between the pulse start time **310** and end time **320**.

[0053] FIG. 4 illustrates a functional block diagram of one embodiment of a multi-sensor wireless transmitter system **40**. The multi-sensor wireless transmitter system **40** includes a magnet **102** that interacts with a multi-sensor transmitter **400**. The multi-sensor transmitter **400** includes an inductor **104** connected to a power supply **402** that is connected to a processor **404** and a transmitter **108**. The inductor **104**, when it interacts with the magnetic field **112** of the magnet **102**, is a power source for the power supply **402**. The power supply **402** provides power to the processor **404** and the transmitter **108**. The processor **404** has a multitude of inputs **406**, for example, inputs from sensors such as switches and transducers. The transmitter **108** has an input from the processor **404** and an output connected to an antenna **110**.

[0054] As with the single sensor burst transmitter system **10**, the magnet **102** moves repetitively relative to the inductor **104**. In one embodiment, the magnet **102** is attached to a machine part that reciprocates or rotates such that the magnet **102** periodically moves past the inductor **104** in direction **114**. The magnet **102** has a magnetic field **112** that periodically interacts with the inductor **104** to produce a pulse **302** in the inductor **104**. In one embodiment, multiple magnets **102** are attached to the machine such that the inductor **104** senses the magnetic field **112** at a rate greater than once per cycle or revolution. In this way the multi-sensor transmitter **400** remains functional with machines that have a low reciprocating rate or a low number of revolutions per second.

[0055] The magnet **102** is dimensioned relative to the moving part of the machine such that the magnetic field **112** is substantially a point source that engages the inductor **104** for a shorter duration than the duration when the magnetic field **112** does not engage the inductor **104**. That is, the interaction of the magnetic field **112** with the inductor **104** occurs briefly compared to the long dwell time with no interaction by the magnetic field **112**. The interaction of the magnetic field **112** occurs during an interaction interval, which can be expressed in units of time or angular displacement. The dwell interval refers to the time or angular displacement where the magnetic field **112** does not interact with the inductor **104**. For those embodiments where a magnet **102** is attached to a moving component of a machine, the magnet **102** will be substantially smaller

than the moving component in order to minimize the mass added to the moving component and to minimize any unbalancing effect from the addition of the magnet **102**. Typically, the ratio of the interaction interval to the dwell interval will be about 1:10 or less. For example, in one embodiment, the magnet **102** is cylindrical and less than 1/2 inch in diameter. The magnet **102** is attached to a rotating pulley that is six inches in diameter. In this example the interaction interval is approximately 10 degrees or less and the dwell interval is approximately 350 degrees or more, which results in the ratio of the interaction interval to the dwell interval of 10:350.

[0056] The processor **404** includes one or more inputs **406**. The processor **404** outputs a signal to the transmitter **108** that includes an identifier and data. The identifier uniquely identifies the multi-sensor transmitter **400** for the embodiment where several transmitters **400** are used concurrently with overlapping range. In this way a receiver is able to identify the transmitter **400** and its corresponding data. The data corresponds to the inputs **406** to the processor **404**.

[0057] As used herein, the processor **404** should be broadly construed to mean any computer or component thereof that executes software. The processor **404** includes a memory medium that stores software, a processing unit that executes the software, and input/output (I/O) units for communicating with external devices. Those skilled in the art will recognize that the memory medium associated with the processor **404** can be either internal or external to the processing unit of the processor without departing from the scope and spirit of the present invention.

[0058] In one embodiment the processor **404** is a general purpose computer, in another embodiment, it is a specialized device for implementing the functions of the invention. Those skilled in the art will recognize that the processor **404** includes an input component, an output component, a storage component, and a processing component. The input component receives input from external devices, such as the switches, sensors, and instruments that can be connected to the inputs **406**. The output component sends output to external devices, such as the transmitter **108**. The storage component stores data and program code. In one embodiment, the storage component includes random access memory. In another embodiment, the storage component includes non-

volatile memory, such as floppy disks, hard disks, and writeable optical disks. The processing component executes the instructions included in the software and routines.

[0059] When multiple multi-sensor transmitter systems **40** are used within range of a single receiver, the transmitters **108** are configured to minimize or reduce interference. For example, in one embodiment, each transmitter **108** operates at a specific frequency or channel different from other transmitters **108**. In another embodiment, the multiple transmitters **108** operate on the same frequency and the received signals are differentiated by the identifier sent by the transmitter **400**. Because the signal has a short duration compared to the time between transmitted signals, collisions are rare. In case of a collision of signals from two transmitters **400**, the next set of transmitted signals should not collide because the difference in the rotational speed of the magnet **102** is sufficiently different to cause the transmitters **400** to transmit at different times, assuming the transmission rate is tied to the rotational speed of the magnet **102**.

[0060] FIG. **5** illustrates a simplified schematic diagram of one embodiment of a power supply **402**. The power supply **402** includes an energy harvester, or voltage multiplier, **522**, a storage circuit **524**, and a voltage regulating circuit **526**.

[0061] The magnet **102** moves periodically in a direction **114** that causes the magnet's flux **112** to induce a current in the inductor **104**. The strength of the magnetic flux **112** and the speed of the magnet **102** as it moves past the inductor **104** influence the magnitude and shape of the induced current signal. In various embodiments, the voltage across the inductor **104** due to the induced current is selected by using a transformer or by adjusting the configuration of the inductor **104**. In one embodiment, the inductor **104** has a length parallel to the magnet direction **114** that is sufficient to produce the desired power from the interaction of the inductor **104** with the magnetic field **112** of the magnet **102**.

[0062] The inductor **104** is a coil that is positioned near where the magnet **102** moves. The leads of the inductor **104** are connected to the power supply **402**, which has an energy harvester **522**, a storage circuit **524**, and a voltage regulating circuit **526**. In the illustrated embodiment, the energy harvester **522** in the power supply **402** is a voltage multiplier. The voltage multiplier circuit **522**

increases the voltage across the inductor **104** to a level suitable for use by the processor **404** and the transmitter **108**. The voltage multiplier circuit **522** includes a network of capacitors **502**, **506** and diodes **504** that has an output voltage **516**, **512** that is greater than the input voltage from the inductor **104**. The voltage multiplier circuit **522** charges the capacitor **508** in the storage circuit **524**.

[0063] The storage unit **524** stores the energy from the inductor **104** at the output voltage **516**, **512** of the voltage multiplier circuit **522**. In the illustrated embodiment the storage unit **524** is a capacitor **508**. The capacitor **508** has a voltage rating sufficient to accommodate the maximum voltage from the voltage multiplier circuit **522**. The capacitor **508** has sufficient capacitance to store the energy from the periodic interactions of the magnet **102** with the inductor **104**, considering the power needs of the processor **404** and the transmitter **108**.

[0064] The capacitance of the capacitor **508** affects the power storage capability and the start up time before such capacity is available. A capacitor **508** with high capacitance, for example, 0.33F, requires several minutes from a cold start before being fully charged by the interaction of the magnetic field **112** with the inductor **104**. Once charged, the capacitor **508** is able to provide power for substantial periods and/or power levels. A capacitor **508** with lower capacitance, for example, 0.022F, is smaller in size, quicker to provide power after a cold start, and provides power for shorter periods and/or at lower power levels.

[0065] The voltage regulating circuit **526** in the illustrated embodiment includes a series of light emitting diodes (LEDs) **410**. The LEDs **410**, across the storage capacitor **508**, serve to regulate the voltage output of the power supply **402**. Red LEDs have a forward voltage of between 1.6 and 2.0 volts, depending upon the doping of the LED. For example, an output voltage of approximately 5 volts can be obtained with three LEDs between the ground **516** and the second output **512**. An output voltage of approximately 3.2 volts can be obtained with two LEDs between the ground **516** and the first output **514**. Until the output capacitor **508** is charged, the output voltages **512**, **514** will be less than the voltage drop across the LEDs **510**. The forward current through the LEDs **510** is limited because the current from the inductor **104** and the voltage multiplier circuit is limited. Another embodiment of the voltage regulating circuit **526** uses

a Zener diode to control the output voltage **512**, **514**. In various embodiments, one or both of the outputs **512**, **514** are used, based on the needs of the processor **404** and transmitter **108**.

[0066] Upon first starting up, the power supply **402** has a zero output voltage. As the magnet **102** interacts with the inductor **104**, the voltage multiplier circuit **522** charges the capacitor **508** in the storage unit **524** to the sum of the forward voltages of the diodes **510** in the voltage regulator circuit **526**. The voltage regulator circuit **526** maintains a relatively constant voltage until current is drawn through the power supply **402**. The voltage output **512**, **514** remains somewhat constant until the output current level increases to the level where the capacity of the inductor **104** and voltage multiplier circuit **522** to keep the storage unit **524** charged is exceeded. The output voltage **512**, **514** then falls. With an increasing load, that is, with a decreasing load impedance, when the output current level reaches a level where the magnet-inductor **102**, **104** interaction cannot supply the full energy requirement, the output voltage **512**, **514** drops, as does the current. The output voltage **512**, **514** recovers only when the load decreases, that is, when the load impedance increases.

[0067] FIG. 5 illustrates a simplified schematic of one embodiment of a power supply **402**. The simplified schematic does not illustrate various connections and components that may be required to accommodate specific components selected and/or desired circuit specifications. For example, the number of capacitors **502**, **506** and diodes **504** in the voltage multiplier circuit **522** depend upon the desired output voltage and power desired at the output **512**, **514**. In another example, the size of the capacitor **508** in the storage unit **524** will vary depending upon the desired start time (larger capacitance requires a greater charging time upon startup) and the power desired for the transmitter **108** (larger capacitance allows for greater energy storage).

[0068] FIG. 6 illustrates a functional block diagram of one embodiment of a wireless tachometer system **60**. The wireless tachometer system **60** includes a tachometer receiver circuit **600** and a conventional tachometer **608**. The tachometer receiver circuit **600** is responsive to a wireless signal from a transmitter **108** that sends pulses corresponding to a rotational speed of a device. In various embodiments, the transmitter **108** is one in a single sensor burst transmitter system **10**, a multi-sensor transmitter system **40**, a wireless

system such as described in US Patent Number 8,035,498 (hereby incorporated by reference), or another wireless system that monitors a rotating device.

[0069] The tachometer receiver circuit **600** includes an antenna **602**, a receiver **604**, a signal conditioner **606**. The antenna **602** and receiver **604** detect the pulses corresponding to the rotational speed of a device desired to be monitored. The signal conditioner **606** is a circuit that converts the output of the receiver **604** into a signal that is compatible with a conventional tachometer **608**. The wireless tachometer **60** monitors engine speed in a vehicle with a wireless connection between the sending unit and the wireless tachometer **60**.

[0070] Typically, vehicles operate with a voltage of 12 Vdc. Wireless receivers **604** provide an analog output signal at half the supply voltage because the receiver output is an ac signal that, at most, fluctuates peak-to-peak between -6 and +6 volts, which is a range of 12 volts but with a maximum voltage of half of the operating voltage. The nominal maximum output of 6 volts for the receiver **604** is reduced further because of the level of the wireless signal fluctuates under normal conditions and receivers **608** are not intended to be operated at maximum gain for long term use. Accordingly, the conventional receiver **604** operating at a 12 volt rail voltage has an output substantially less than 6 volts. For example, a 10db reduction from maximum, which is not normally considered a substantial reduction, results in an output level of 0.6 volts, which is insufficient to drive a conventional tachometer **608**.

[0071] Conventional tachometers **608** require an input signal of 12 Vdc pulses because the conventional tachometer **608** is configured to be connected directly to the vehicle's coil or a tach output on an electronic ignition. The output of conventional receivers **604** are not compatible with the input of conventional tachometers **608**. To correct the mismatch of voltage levels, a signal conditioner **606** matches the output of the conventional receiver **604** to the input of the conventional tachometer **608**. Without the signal conditioner **606**, the conventional tachometer **608** cannot provide a reliable indication with only the output of the conventional receiver **604**.

[0072] In one embodiment, the wireless tachometer system **60** functions with a wireless input corresponding to a signal with two pulses per revolution and with the conventional automotive tachometer **608** configured with a setting

corresponding to a 6 cylinder engine. The two pulses received for the wireless input correspond to a wireless transmitter sensing two magnets on the rotating member. For those conventional automotive tachometers **608** that include a pulse per revolution (PPR) setting, the tachometer PPR setting is adjusted to correspond to the number of magnets **102** used.

[0073] FIG. **7** illustrates a schematic diagram for one embodiment of a signal conditioner **606-A** for a wireless tachometer system **60**. In the illustrated embodiment, an operational amplifier (op amp) **702** conditions the output signal **708** from the receiver **604** into a signal that is compatible with the tachometer **608**. The capacitor **704** and variable resistor **706** are connected across the gain connections of the op amp **702** to control the level of the output **710**.

[0074] In one such embodiment, the op amp **702** is an LM386, the capacitor **704** is 10 μ F, and the resistor **706** is 10K ohms. In another embodiment, the op amp **702** is an LM4861 and the resistor **706** is not used. The input **708** to the signal conditioner **606-A** is the low voltage output of the receiver **604**. That is, the input **708** to the signal conditioner **606-A** is at a nominal maximum of 6 volts. The gain of the signal conditioner **606-A** is such that the output **710** is at a nominal 12 Vdc, which is sufficient to trigger the conventional automotive tachometer **608** reliably. In one such embodiment, the operational amplifier functions as a comparator with the gain set to minimize overdriving the operational amplifier while avoiding saturation.

[0075] FIG. **8** illustrates a schematic diagram for another embodiment of a signal conditioner **606-B**. In the illustrated embodiment, a step up transformer **802** is used to convert the input **708** to the output **710**. In one such embodiment, the transformer **802** has a ratio of 3:1. In one such embodiment, the transformer **802** has a turns ratio of at least 5:1.

[0076] The input **708** to the signal conditioner **606-B** is the low voltage output of the receiver **604**, which is at a nominal maximum of 6 volts. The ratio of the transformer **802** is such that the output **710** is at a nominal 12 Vdc, which is sufficient to trigger the conventional automotive tachometer **608** reliably.

[0077] The output of the conventional receiver **604** is an alternating current (ac) signal. The transformer **802** steps up the receiver output voltage to a level that ensures reliable operation of the conventional tachometer **608**. In one such embodiment, the gain of the receiver **604** is set or adjusted so that the output of the transformer **802** is at or near the operating voltage of the vehicle. In another such embodiment, the turns ratio of the transformer **802** is selected such that the output of the transformer **802** is at or near the operating voltage of the vehicle considering the output of the receiver **604**. For installations where the transmitted signal strength is fixed and with a receiver **604** having a fixed gain, the transformer ratio is selected to provide an output that is greater than the minimum voltage requirement of the tachometer **608** and less than the saturation or maximum voltage of the tachometer **608**.

[0078] FIGS. **7** and **8** illustrate a simplified schematics of the signal conditioners **606**. The simplified schematics do not illustrate various connections that may be required to accommodate specific components selected, for example, voltage and/or current limiters.

[0079] The multi-sensor wireless transmitter system **40** includes various functions. The function of generating power is implemented, in one embodiment, by the inductor **104**, which interacts with the magnet **102**.

[0080] The function of providing power to the processor **404** and the transmitter **108** is implemented, in one embodiment, by the inductor **104**, which interacts with the magnet **102**, with the inductor **104** connected to the power supply **402**.

[0081] The function of harvesting power is implemented, in one embodiment, by the voltage multiplier **522** and storage circuit **524**. The power generated by the inductor **104** interacting with the magnet **102** is collected and stored in the storage circuit **524**.

[0082] The function of regulating the voltage of the power supply **402** is implemented, in one embodiment, by the voltage regulating circuit **526**. In one such embodiment, the voltage regulating circuit **524** includes a series of light emitting diodes (LEDs) **510**. In another such embodiment, the voltage regulating circuit **524** includes one or more Zener diodes.

[0083] From the foregoing description, it will be recognized by those skilled in the art that a self-powered, multi-sensor wireless transmitter system **40** has been provided. The wireless transmitter system **40** has a minimal parts count, requires no external wiring for supplying power and connectivity, and has a low cost of installation and maintenance.

[0084] The single sensor burst transmitter system **10** includes various functions. The function of generating power and a trigger signal is implemented, in one embodiment, by the inductor **104**, which interacts with the magnet **102**.

[0085] The function of ensuring the transmitted pulse **306** is transmitted at a specific time is implemented, in one embodiment, by the delay **106**, which ensure the trigger input **Tr** is at a voltage sufficient to trigger the transmitter unit **108** before the transmitter unit **108** has sufficient power to be energized.

[0086] From the foregoing description, it will be recognized by those skilled in the art that a self-powered, single sensor burst wireless transmitter system **10** has been provided. The wireless transmitter system **10** has a minimal parts count, requires no external wiring, and has a low cost of installation and maintenance.

[0087] In one embodiment of a single sensor burst transmitter system **10**, an apparatus for monitoring a parameter corresponding to a moving component, the single sensor burst transmitter system **10** includes a transmitter **108** having a trigger input **Tr**, a supply voltage input **Vcc**, a ground **Ref**, and an output **Ant**, said transmitter **108** configured to provide a wireless signal based on said trigger input **Tr**; an inductor **104** connected between said trigger input **Tr** and said ground **Ref** of said transmitter **108**, said inductor **104** responsive to a magnetic field **112** moving relative to said inductor **104**; and a delay circuit **106** connected between said ground **Ref** and said supply voltage input **Vcc** of said transmitter **108**, said delay circuit **106** adding a delay to a signal applied to said supply voltage input **Vcc** whereby said supply voltage input **Vcc** reaches a minimum required operating voltage level **314** after said trigger input **Tr** reaches a minimum required trigger voltage level **312**.

[0088] In one such embodiment, the single sensor burst transmitter system **10** further includes a magnet **102** that generates said magnetic field **112**. In one such embodiment of the single sensor burst transmitter system **10**, the minimum required trigger voltage level **312** and said minimum required operating voltage level **314** are substantially the same. In one such embodiment of the single sensor burst transmitter system **10**, a sole source of power for said transmitter **108** is said magnetic field **112** interacting with said inductor **104**. In one such embodiment of the single sensor burst transmitter system **10**, the inductor **102** provides sufficient power to operate said transmitter **108**. In one such embodiment of the single sensor burst transmitter system **10**, the output of said transmitter **108** is connected to an antenna **110** that transmits said wireless signal. In one such embodiment of the single sensor burst transmitter system **10**, the wireless signal is a pulse having a width equal to a time differential between when said supply voltage input **Vcc** reaches said minimum required operating voltage level and when either said supply voltage input **Vcc** falls below said minimum required operating voltage level **314** or said trigger input **Tr** falls below said minimum required trigger voltage level **312**. In one such embodiment of the single sensor burst transmitter system **10**, the delay circuit includes a resistor **202** and capacitor **204** connected in parallel.

[0089] In another embodiment of a single sensor burst transmitter system **10**, an apparatus for monitoring a parameter corresponding to a moving component, the single sensor burst transmitter system **10** includes a transmitter **108** configured to transmit a wireless signal; a magnet **102** having a magnetic field **112**; an inductor **104** responsive to said magnetic field **112** when said magnet **102** moves relative to said inductor **104**, said inductor **104** triggering said transmitter **108** when said magnetic field **112** interacts with said inductor **104**; and a delay circuit **106** connected to said inductor **104** and said transmitter **108**, said delay circuit **106** providing power to said transmitter **108** after said transmitter **108** is triggered by said inductor **104** whereby said wireless signal is a pulse corresponding to a time when said magnetic field is interacting with said inductor **104**.

[0090] In one such embodiment of the single sensor burst transmitter system **10**, the magnet is configured to be attached to a component of a machine where said component moves relative to said inductor **104**. In one such

embodiment of the single sensor burst transmitter system **10**, the transmitter **108** includes a trigger input **Tr**, a supply voltage input **Vcc**, and a ground **Ref**, said inductor **104** connected between said trigger input **Tr** and said ground **Ref**, said delay circuit **106** connected between said ground and said supply voltage input. In one such embodiment of the single sensor burst transmitter system **10**, the transmitter **108** includes a trigger input and a supply voltage input, said inductor **104** providing a minimum required trigger voltage level to said trigger input before said supply voltage input reaches a minimum required operating voltage level from said delay circuit **106**. In one such embodiment of the single sensor burst transmitter system **10**, the wireless signal is a pulse having a width equal to a time differential between when a supply voltage input of said transmitter **108** reaches a minimum required operating voltage level and when either said supply voltage input falls below said minimum required operating voltage level or a trigger input of said transmitter **108** falls below a minimum required trigger voltage level. In one such embodiment of the single sensor burst transmitter system **10**, the delay circuit includes a resistor and capacitor connected in parallel between a ground of said transmitter and a supply voltage input of said transmitter **108**. In one such embodiment of the single sensor burst transmitter system **10**, the transmitter **104** is connected to an antenna **110** that transmits said wireless signal.

[0091] In yet another embodiment of a single sensor burst transmitter system **10**, an apparatus for monitoring a parameter corresponding to a moving component, the single sensor burst transmitter system **10** includes a magnet **102** having a magnetic field; an inductor **104** responsive to said magnetic field **112** when there is relative motion between said magnet **102** and said inductor **104**; a delay circuit **106** electrically connected to said inductor; a transmitter **108** electrically connected to said inductor, said transmitter electrically connected to said delay circuit, said transmitter powered solely by said magnetic field interacting with said inductor, said transmitter **108** receiving a trigger signal from said inductor **104** when said magnetic field interacts with said inductor **104**; and an antenna electrically connected to said transmitter **108**, said antenna transmitting a wireless signal that is a pulse corresponding to said magnetic field interacting with said inductor **104**.

[0092] In one such embodiment of the single sensor burst transmitter system **10**, the transmitter **108** includes a trigger input, a supply voltage input, and a ground, said inductor connected between said trigger input and said ground of said transmitter, said delay circuit **106** connected between said ground and said supply voltage input of said transmitter **108**. In one such embodiment of the single sensor burst transmitter system **10**, the transmitter **108** includes a trigger input **Tr** and a supply voltage input **Vcc**, said inductor **104** providing a minimum required trigger voltage level to said trigger input before said supply voltage input reaches a minimum required operating voltage level from said delay circuit **106**. In one such embodiment of the single sensor burst transmitter system **10**, the delay circuit **106** includes a resistor **202** and capacitor **204** connected in parallel between a ground **Ref** of said transmitter **108** and a supply voltage input **Vcc** of said transmitter **108**. In one such embodiment of the single sensor burst transmitter system **10**, the magnet **102** is configured to attach to a component that moves relative to said inductor **104**.

[0093] While the present invention has been illustrated by description of several embodiments and while the illustrative embodiments have been described in considerable detail, it is not the intention of the applicant to restrict or in any way limit the scope of the appended claims to such detail. Additional advantages and modifications will readily appear to those skilled in the art. The invention in its broader aspects is therefore not limited to the specific details, representative apparatus and methods, and illustrative examples shown and described. Accordingly, departures may be made from such details without departing from the spirit or scope of applicant's general inventive concept.

CLAIMS

What is claimed is:

1. An apparatus for a wireless transmitter powered from a machine with a component that has a periodic motion, said apparatus comprising:

a magnet having a magnetic field;

an inductor configured to be positioned proximate said magnet such that said magnetic field interacts with said inductor when said magnet moves relative to said inductor;

a voltage multiplier electrically connected to said inductor, said voltage multiplier having an output voltage greater than a voltage induced across said inductor by said magnetic field; and

a storage circuit electrically connected to an output of said voltage multiplier, said voltage multiplier and said storage circuit defining a power supply, said power supply having an output.

2. The apparatus of Claim 1 wherein said storage circuit includes a capacitor.

3. The apparatus of Claim 1 wherein said magnetic field interacting with said inductor is a sole source of power for said power supply.

4. The apparatus according to one of the preceding claims wherein said magnet is configured to attach to the component such that said magnet moves relative to said inductor with the periodic motion of the component.

5. The apparatus according to one of the preceding claims wherein said magnet is dimensioned and configured such that said magnetic field is substantially a point source compared to a dwell interval.

6. The apparatus according to one of the preceding claims wherein said magnet is dimensioned and configured such that said magnetic field has a ratio of an interaction interval to a dwell interval of no more than 1:10, wherein said ratio is defined as a relationship between a first time when said magnetic field periodically interacts with said inductor and a second time when said magnetic field does not interact with said inductor.

7. The apparatus according to one of the preceding claims wherein said power supply further includes a voltage regulating circuit electrically connected to said storage circuit and said output of said power supply.

8. The apparatus of Claim 7 wherein said voltage regulator includes at least one diode.

9. The apparatus of Claim 8 wherein said at least one diode is a light emitting diode.

10. The apparatus according to one of the preceding claims further including a transmitter electrically connected to said output of said power supply, said transmitter sending a wireless signal corresponding to at least one parameter being monitored.

11. The apparatus of Claim 10 further including an antenna connected to said transmitter.

12. The apparatus according to Claim 10 or 11 further including a processor electrically connected to said output of said power supply, said processor having at least one input that is responsive to a corresponding one of said at least one parameter being monitored, said processor having an output based on said at least one input, said output from said processor connected to said transmitter, and said wireless signal corresponding to said output of said processor.

13. The apparatus of Claim 12 wherein said output of said processor includes data representing said at least one input.

14. The apparatus of Claim 13 wherein said output of said processor further includes an identifier, and said identifier being a code identifying said transmitter.

15. The apparatus of Claim 12 wherein said magnetic field interacting with said inductor is a sole source of power for said processor and said transmitter.

16. An apparatus for a self-powered wireless transmitter associated with a component that has motion, said apparatus comprising:

a magnet configured to be attached to the moving component wherein said component moves with a periodic motion;

an inductor configured to be positioned proximate said magnet such that a magnetic field from said magnet interacts with said inductor when said magnet moves relative to said inductor;

a power supply circuit electrically connected to said inductor, said power supply circuit including a voltage multiplier connected to a storage circuit, which is connected to a voltage regulating circuit;

a processor electrically connected to said power supply, said processor having at least one input that is responsive to a corresponding external condition, said processor having an output based on said at least one input; and

a transmitter electrically connected to said power supply, said transmitter connected to said output from said processor, said transmitter connected to an antenna, said transmitter sending a wireless signal corresponding to said output of said processor.

17. The apparatus of Claim 16 wherein said voltage multiplier has an output voltage greater than a voltage induced across said inductor by said magnetic field.

18. The apparatus of Claim 16 wherein said voltage regulator includes at least one diode.

19. The apparatus of Claim 16 wherein said output of said processor includes an data representing said at least one input.

20. The apparatus of Claim 16 wherein said output of said processor includes an identifier and data, said identifier being a code identifying said transmitter, said data representing said at least one input.

21. The apparatus of Claim 16 wherein said magnetic field interacting with said inductor is a sole source of power for said power supply.

22. The apparatus of Claim 16 wherein said magnetic field interacting with said inductor is a sole source of power for said processor and said transmitter.

23. The apparatus of Claim 16 wherein said magnet is dimensioned and configured such that said magnetic field is substantially a point source compared to a dwell interval.

24. The apparatus of Claim 16 wherein said magnet is dimensioned and configured such that said magnetic field has a ratio of an interaction interval to a dwell interval of no more than 1:10, wherein said ratio is defined as a comparison between a first time when said magnetic field periodically interacts with said inductor and a second time when said magnetic field does not interact with said inductor as the moving component moves relative to said inductor.

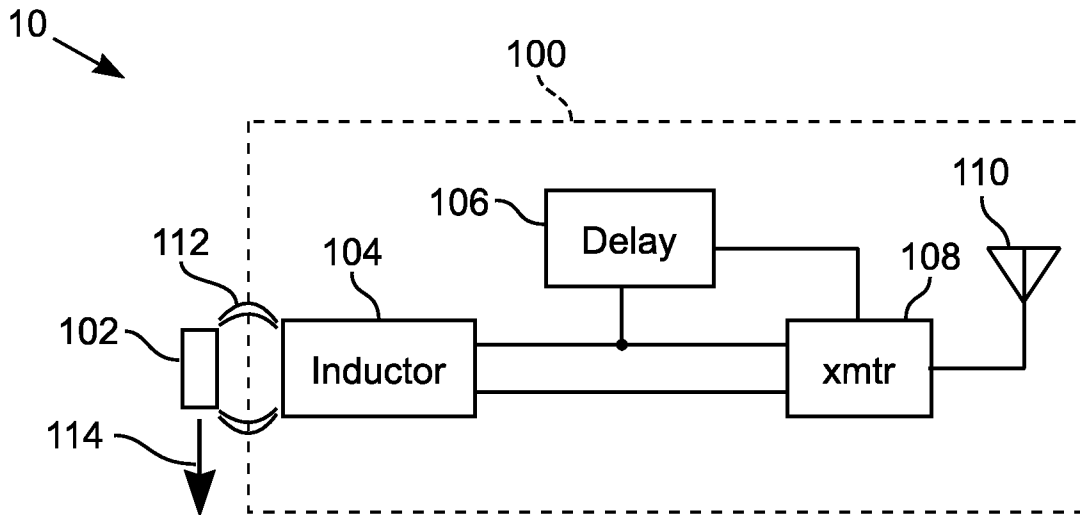

Fig. 1

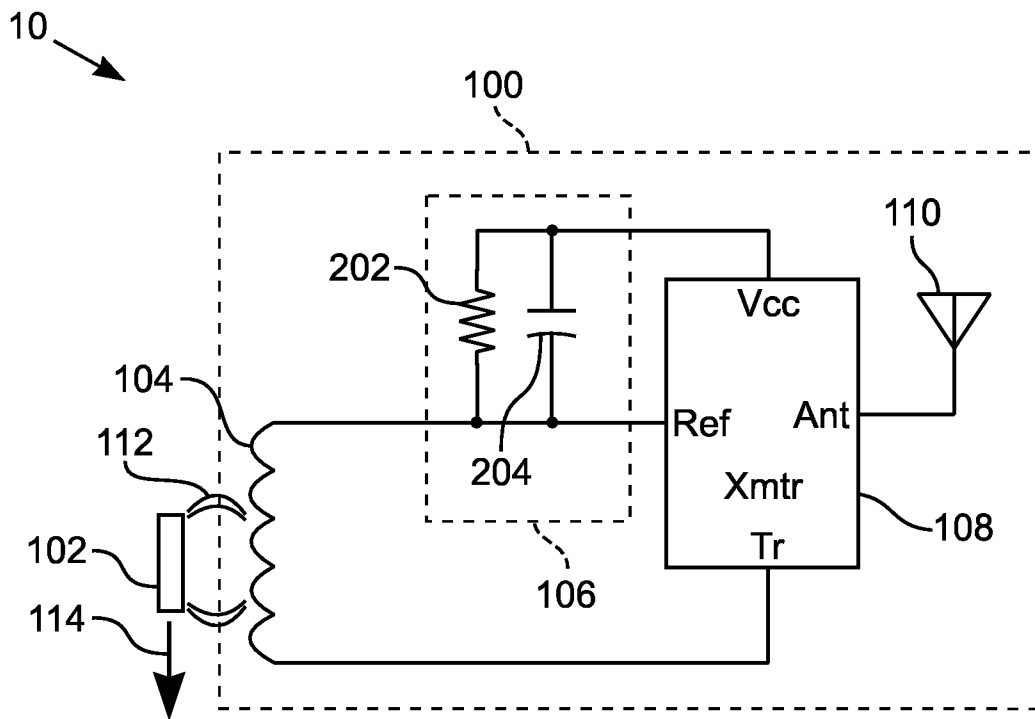
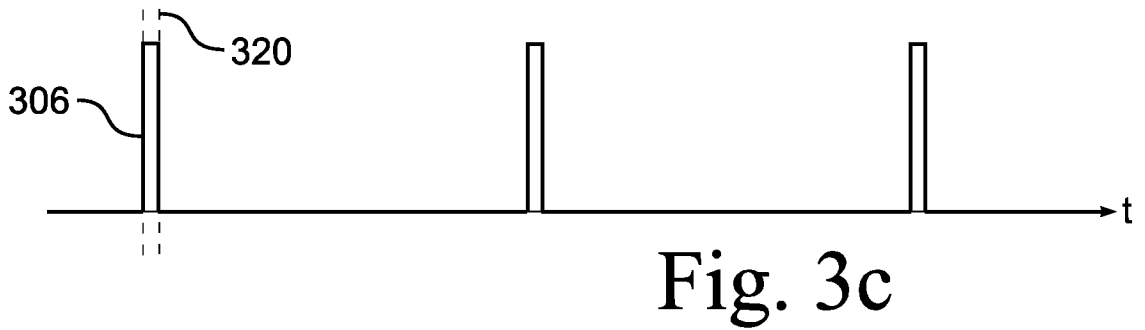
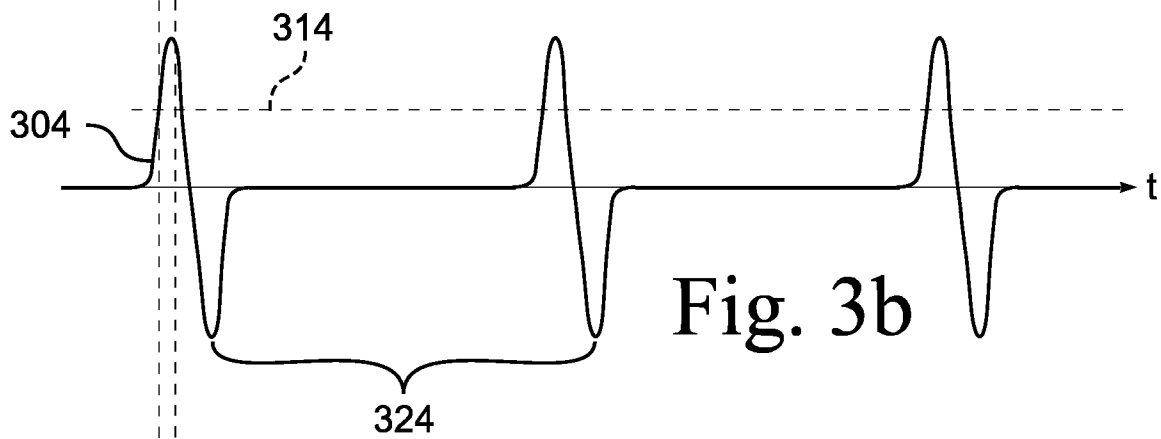
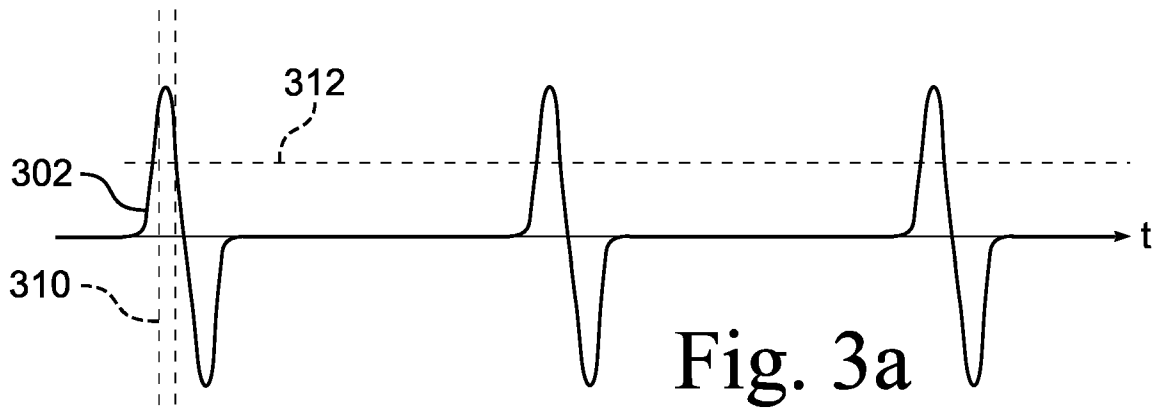

Fig. 2



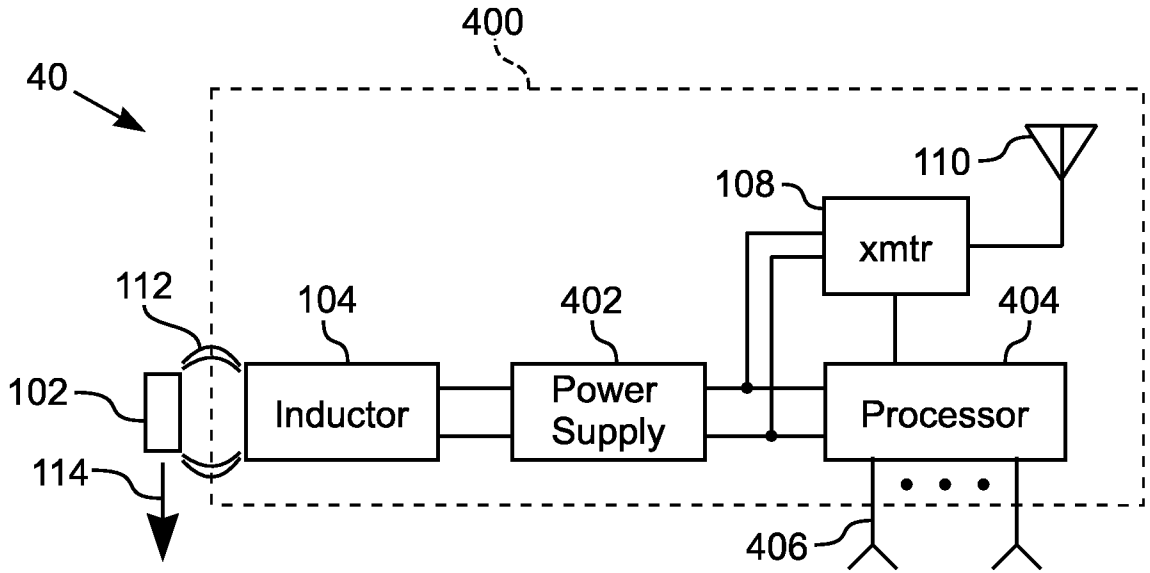

Fig. 4

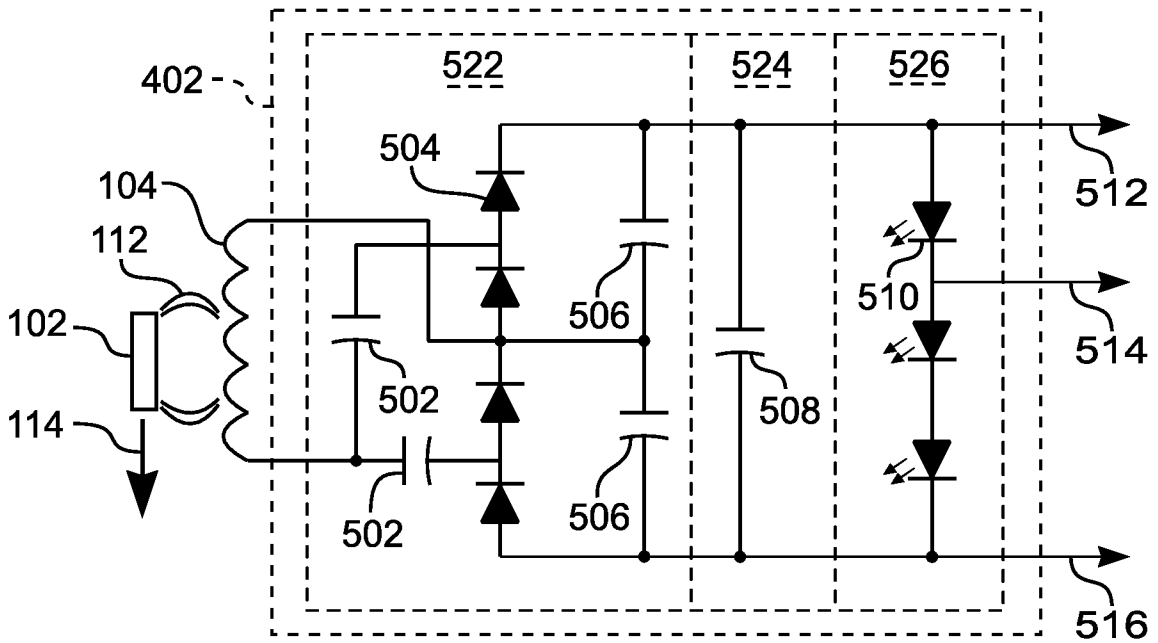

Fig. 5

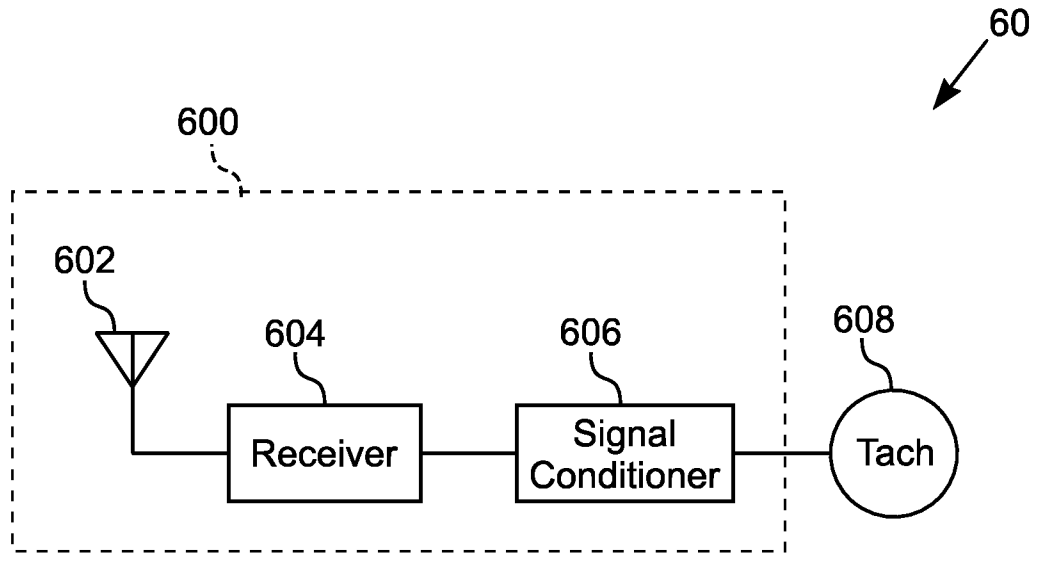

Fig. 6

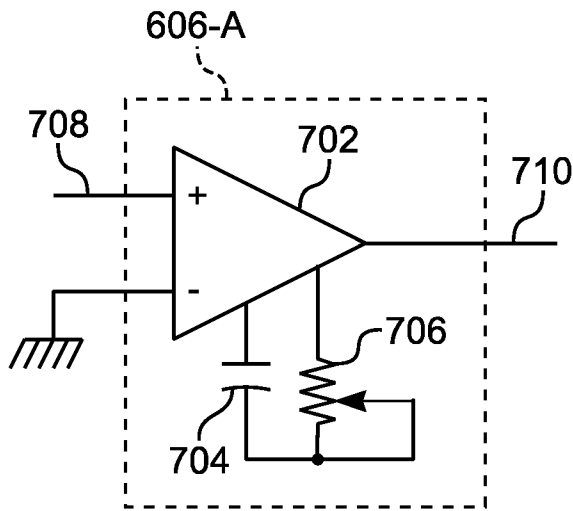

Fig. 7

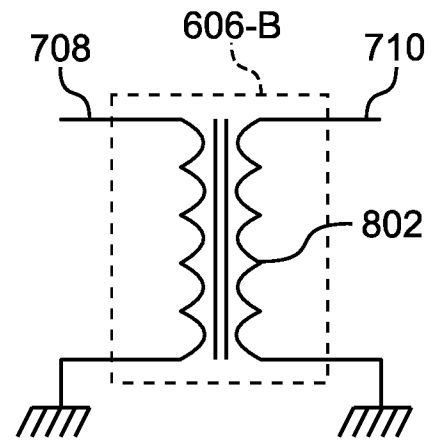

Fig. 8

INTERNATIONAL SEARCH REPORT

International application No.

PCT/US13/38612

<p>A. CLASSIFICATION OF SUBJECT MATTER IPC(8) - G01P 3/487 (2013.01) USPC - 73/494 According to International Patent Classification (IPC) or to both national classification and IPC</p>																	
<p>B. FIELDS SEARCHED</p> <p>Minimum documentation searched (classification system followed by classification symbols) IPC(8) Classification(s): G01P 3/487; B60C 23/02; G01M 17/02 (2013.01) USPC Classification(s): 73/494; 73/115.08; 340/441; 340/432</p> <p>Documentation searched other than minimum documentation to the extent that such documents are included in the fields searched</p> <p>Electronic data base consulted during the international search (name of data base and, where practicable, search terms used) MicroPatent (US-G, US-A, EP-A, EP-B, WO, JP-bib, DE-C,B, DE-A, DE-T, DE-U, GB-A, FR-A); DialogPro (Derwent, INSPEC, NTIS, PASCAL, Current Contents Search, Dissertation Abstracts Online, Inside Conferences); IP.com; Google transmitter, storage, induction, multiplier, magnet</p>																	
<p>C. DOCUMENTS CONSIDERED TO BE RELEVANT</p> <table border="1"> <thead> <tr> <th>Category*</th> <th>Citation of document, with indication, where appropriate, of the relevant passages</th> <th>Relevant to claim No.</th> </tr> </thead> <tbody> <tr> <td>X --- Y</td> <td>US 2008/0042816 A1 (PENNISI, T et al.), 21 February 2008, Figure 2 and 5; Paragraphs [0030] and [0036]-[0038].</td> <td>1-4 ----- 16-24</td> </tr> <tr> <td>Y</td> <td>US 2009/0091309 A1 (BALAKRISHNAN, B et al.), 9 April 2009, Figures 2 and 3; Paragraphs [0005]-[0006] and [0041]-[0042].</td> <td>16-24</td> </tr> <tr> <td>Y</td> <td>US 3974477 A (HESTER, S), 10 August 1976, Column 3, Lines 42-60.</td> <td>24</td> </tr> <tr> <td>A</td> <td>US 2007/0295070 A1 (HUANG, S et al.), 27 December 2007, the whole document.</td> <td>1-4 and 16-24</td> </tr> </tbody> </table>			Category*	Citation of document, with indication, where appropriate, of the relevant passages	Relevant to claim No.	X --- Y	US 2008/0042816 A1 (PENNISI, T et al.), 21 February 2008, Figure 2 and 5; Paragraphs [0030] and [0036]-[0038].	1-4 ----- 16-24	Y	US 2009/0091309 A1 (BALAKRISHNAN, B et al.), 9 April 2009, Figures 2 and 3; Paragraphs [0005]-[0006] and [0041]-[0042].	16-24	Y	US 3974477 A (HESTER, S), 10 August 1976, Column 3, Lines 42-60.	24	A	US 2007/0295070 A1 (HUANG, S et al.), 27 December 2007, the whole document.	1-4 and 16-24
Category*	Citation of document, with indication, where appropriate, of the relevant passages	Relevant to claim No.															
X --- Y	US 2008/0042816 A1 (PENNISI, T et al.), 21 February 2008, Figure 2 and 5; Paragraphs [0030] and [0036]-[0038].	1-4 ----- 16-24															
Y	US 2009/0091309 A1 (BALAKRISHNAN, B et al.), 9 April 2009, Figures 2 and 3; Paragraphs [0005]-[0006] and [0041]-[0042].	16-24															
Y	US 3974477 A (HESTER, S), 10 August 1976, Column 3, Lines 42-60.	24															
A	US 2007/0295070 A1 (HUANG, S et al.), 27 December 2007, the whole document.	1-4 and 16-24															
<p><input type="checkbox"/> Further documents are listed in the continuation of Box C. <input type="checkbox"/></p>																	
<p>* Special categories of cited documents:</p> <table border="0"> <tr> <td>"A" document defining the general state of the art which is not considered to be of particular relevance</td> <td>"T" later document published after the international filing date or priority date and not in conflict with the application but cited to understand the principle or theory underlying the invention</td> </tr> <tr> <td>"E" earlier application or patent but published on or after the international filing date</td> <td>"X" document of particular relevance; the claimed invention cannot be considered novel or cannot be considered to involve an inventive step when the document is taken alone</td> </tr> <tr> <td>"L" document which may throw doubts on priority claim(s) or which is cited to establish the publication date of another citation or other special reason (as specified)</td> <td>"Y" document of particular relevance; the claimed invention cannot be considered to involve an inventive step when the document is combined with one or more other such documents, such combination being obvious to a person skilled in the art</td> </tr> <tr> <td>"O" document referring to an oral disclosure, use, exhibition or other means</td> <td>"&" document member of the same patent family</td> </tr> <tr> <td>"P" document published prior to the international filing date but later than the priority date claimed</td> <td></td> </tr> </table>			"A" document defining the general state of the art which is not considered to be of particular relevance	"T" later document published after the international filing date or priority date and not in conflict with the application but cited to understand the principle or theory underlying the invention	"E" earlier application or patent but published on or after the international filing date	"X" document of particular relevance; the claimed invention cannot be considered novel or cannot be considered to involve an inventive step when the document is taken alone	"L" document which may throw doubts on priority claim(s) or which is cited to establish the publication date of another citation or other special reason (as specified)	"Y" document of particular relevance; the claimed invention cannot be considered to involve an inventive step when the document is combined with one or more other such documents, such combination being obvious to a person skilled in the art	"O" document referring to an oral disclosure, use, exhibition or other means	"&" document member of the same patent family	"P" document published prior to the international filing date but later than the priority date claimed						
"A" document defining the general state of the art which is not considered to be of particular relevance	"T" later document published after the international filing date or priority date and not in conflict with the application but cited to understand the principle or theory underlying the invention																
"E" earlier application or patent but published on or after the international filing date	"X" document of particular relevance; the claimed invention cannot be considered novel or cannot be considered to involve an inventive step when the document is taken alone																
"L" document which may throw doubts on priority claim(s) or which is cited to establish the publication date of another citation or other special reason (as specified)	"Y" document of particular relevance; the claimed invention cannot be considered to involve an inventive step when the document is combined with one or more other such documents, such combination being obvious to a person skilled in the art																
"O" document referring to an oral disclosure, use, exhibition or other means	"&" document member of the same patent family																
"P" document published prior to the international filing date but later than the priority date claimed																	
<p>Date of the actual completion of the international search 21 June 2013 (21.06.2013)</p>		<p>Date of mailing of the international search report 08 JUL 2013</p>															
<p>Name and mailing address of the ISA/US Mail Stop PCT, Attn: ISA/US, Commissioner for Patents P.O. Box 1450, Alexandria, Virginia 22313-1450 Facsimile No. 571-273-3201</p>		<p>Authorized officer: Shane Thomas</p> <p>PCT Helpdesk: 571-272-4300 PCT OSP: 571-272-7774</p>															

INTERNATIONAL SEARCH REPORT

International application No.

PCT/US13/38612

Box No. II Observations where certain claims were found unsearchable (Continuation of item 2 of first sheet)

This international search report has not been established in respect of certain claims under Article 17(2)(a) for the following reasons:

- 1. Claims Nos.:
because they relate to subject matter not required to be searched by this Authority, namely:

- 2. Claims Nos.:
because they relate to parts of the international application that do not comply with the prescribed requirements to such an extent that no meaningful international search can be carried out, specifically:

- 3. Claims Nos.: 5-15
because they are dependent claims and are not drafted in accordance with the second and third sentences of Rule 6.4(a).

Box No. III Observations where unity of invention is lacking (Continuation of item 3 of first sheet)

This International Searching Authority found multiple inventions in this international application, as follows:

- 1. As all required additional search fees were timely paid by the applicant, this international search report covers all searchable claims.
- 2. As all searchable claims could be searched without effort justifying additional fees, this Authority did not invite payment of additional fees.
- 3. As only some of the required additional search fees were timely paid by the applicant, this international search report covers only those claims for which fees were paid, specifically claims Nos.:

- 4. No required additional search fees were timely paid by the applicant. Consequently, this international search report is restricted to the invention first mentioned in the claims; it is covered by claims Nos.:

Remark on Protest

- The additional search fees were accompanied by the applicant's protest and, where applicable, the payment of a protest fee.
- The additional search fees were accompanied by the applicant's protest but the applicable protest fee was not paid within the time limit specified in the invitation.
- No protest accompanied the payment of additional search fees.