

(No Model.)

2 Sheets—Sheet 1.

J. J. RENEHAN.
ELECTRIC LAMP SUPPORT.

No. 523,007.

Patented July 17, 1894.

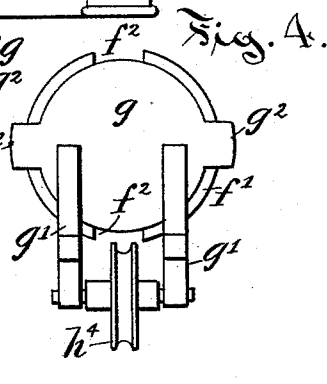
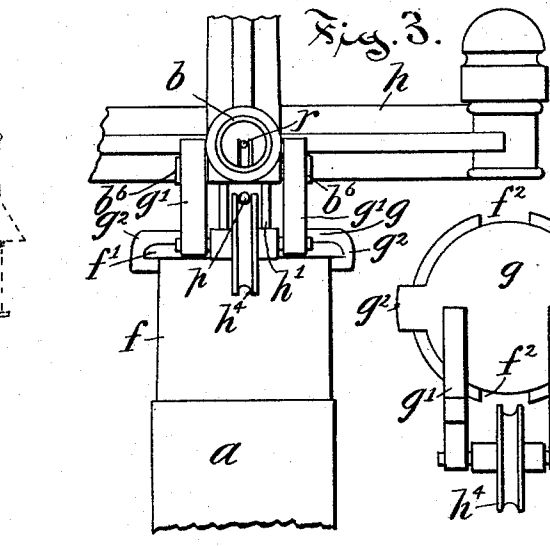
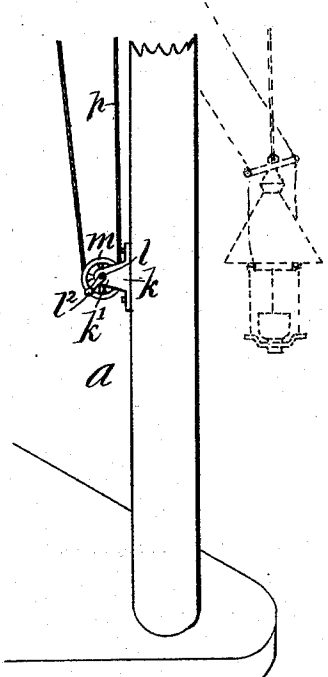
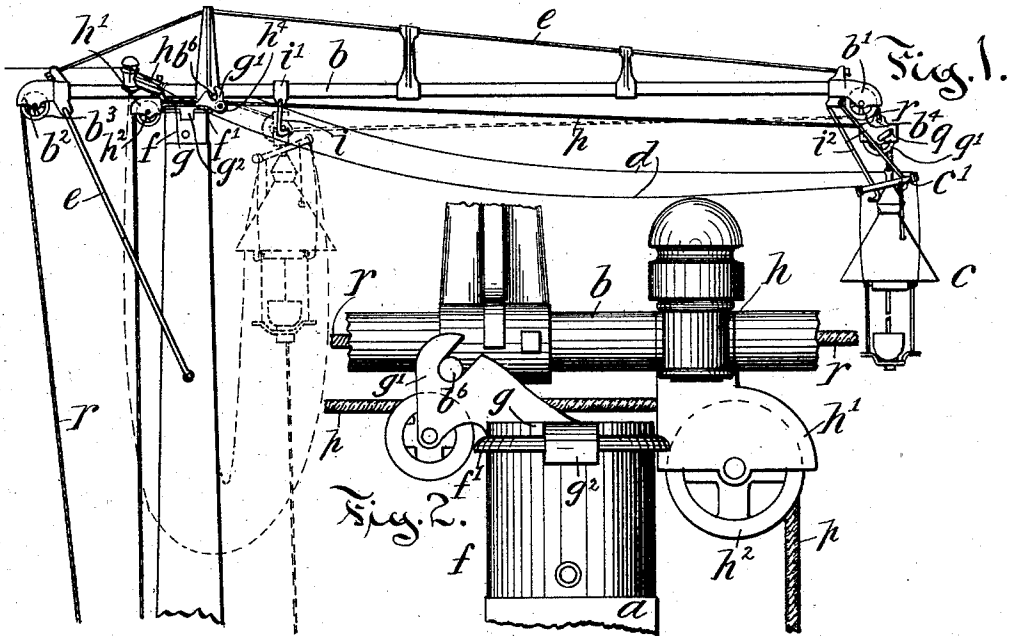

Witnesses:
Joseph Arthur Cantin
Arthur B. Jenkins

Inventor:
James J. Renahan.
By Simonds, Bunker & Frothingham
Attorneys.

(No Model.)

2 Sheets—Sheet 2.

J. J. RENEHAN.
ELECTRIC LAMP SUPPORT.

No. 523,007.

Patented July 17, 1894.

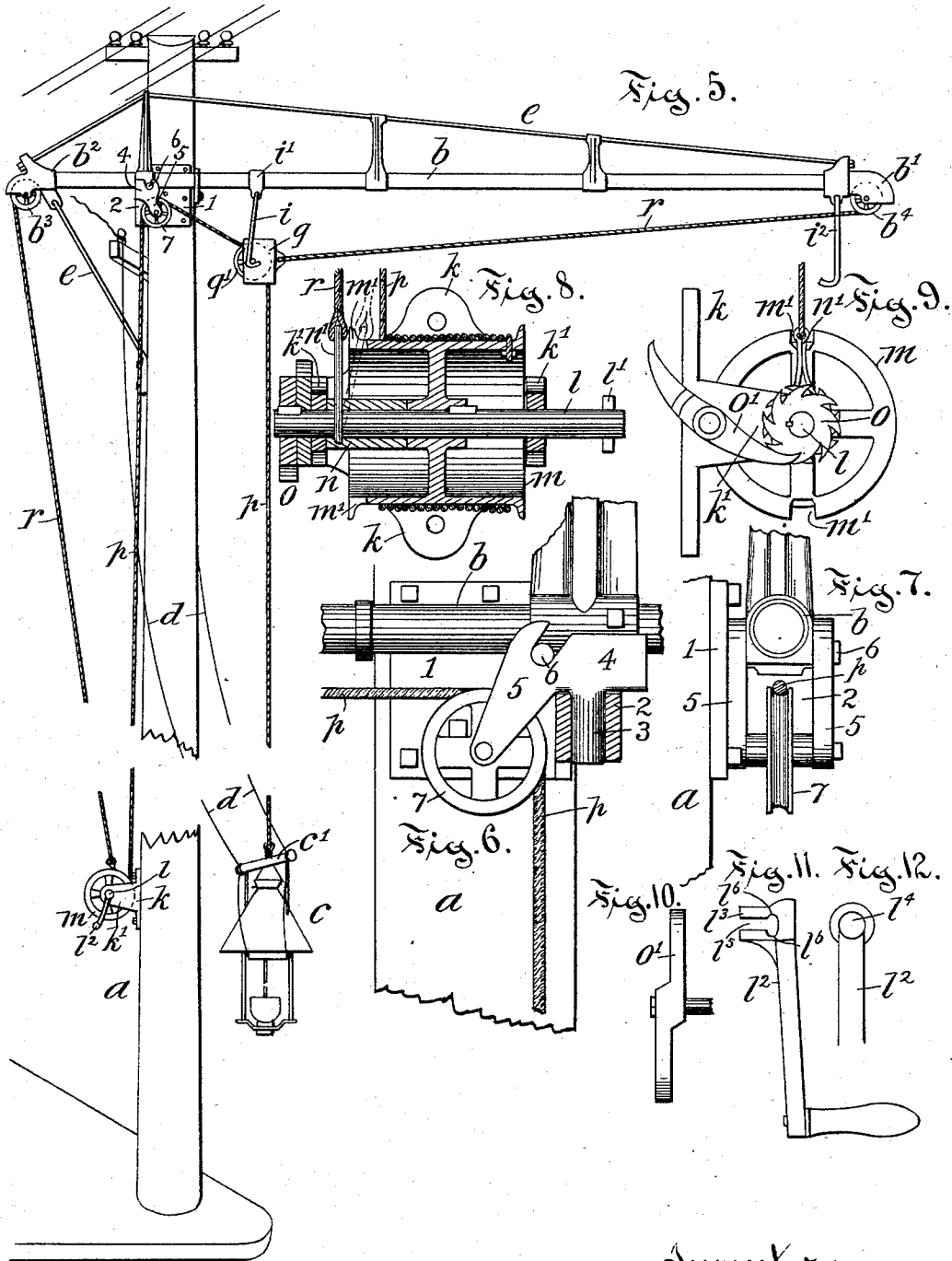

Witnesses:
 Joseph Arthur Carter.
 Arthur P. Jenkins.

Inventor:
 James J. Renahan
 by Simon D. Burdett & Frothingham
 Attorneys.

UNITED STATES PATENT OFFICE.

JAMES J. RENEHAN, OF NEW BRITAIN, CONNECTICUT.

ELECTRIC-LAMP SUPPORT.

SPECIFICATION forming part of Letters Patent No. 523,007, dated July 17, 1894.

Application filed November 21, 1893. Serial No. 491,527. (No model.)

To all whom it may concern:

Be it known that I, JAMES J. RENEHAN, of New Britain, in the county of Hartford and State of Connecticut, have invented certain new and useful Improvements in Electric-Lamp Supports, of which the following is a full, clear, and exact description, whereby any one skilled in the art can make and use the same.

My invention relates to the class of electric lamp supports whereby a lamp may be suspended directly over a roadway, the mast being erected at one side of the road and the lamp depending from the outer end of an arm secured to the mast and projecting over the roadway, and the object of my invention is to provide a support of this class in which the arm may be secured to the mast and then swung into proper position for use; and a further object of my invention is to provide a device by means of which the lamp may be moved from the outer end of the arm in a substantially horizontal line to a position near the inner end thereof, and then lowered to the ground without any extra labor on the part of the operator.

To this end my invention consists in the details of the several parts comprising the lamp support, in the means for uniting the parts, in the means for changing the position of the lamp, and in the combination of such parts, as more particularly hereinafter described and pointed out in the claims.

Referring to the drawings: Figure 1 is a view in side elevation of my improved support showing in dotted outline the lamp in its different positions. Fig. 2 is a detail side view of the upper part of the mast and the inner end of the arm showing the manner of connection. Fig. 3 is a detail front view of the same. Fig. 4 is a detail top view of the swivel plate and rear pulley support. Fig. 5 is a view in side elevation of a mast and arm showing a modified form of connection between such parts. Fig. 6 is a detail view of the upper part of the mast and inner end of the arm, showing this modified form of connection, the parts being connected on the opposite side of the pole from that shown in Fig. 5. Fig. 7 is a front view of the same. Fig. 8 is a detail view showing the drum and con-

nected parts. Fig. 9 is a detail end view of the same. Fig. 10 is a detail edge view showing the gravity pawl. Fig. 11 is a detail side view of my improved crank. Fig. 12 is a detail end view of the same.

In many places the use of the trolley system of electric railways and of other electrical contrivances requires the use of a large number of wires overlying the street at a level below that at which an electric light is usually suspended. In such cases where a mast and arm are used for supporting the lamp in position over the street or roadway it is desirable that the means of connection between the mast and arm shall be such that the arm may be secured to the mast in a different position from that in which it normally rests and may then be swung to its normal position. It is also desirable that means shall be provided for moving the lamp horizontally between the end of the arm and mast and also means for moving the lamp vertically in a position near the mast.

In the accompanying drawings the letter *a* denotes a mast and *b* an arm projecting from the mast and adapted to support on its outer end an electric lamp *c*, the wires *d* being fastened to the mast and connected to the lamp in any usual manner. Braces *e* of any ordinary form and construction may be employed as an aid in strengthening the parts and in holding the arm *b* in its extended position.

The arm *b* is preferably hollow, or it may be concaved as to its under surface, and there are removably secured at or near each end of the arm hoods *b'* *b''*, in which are pivoted the pulleys *b³*, *b⁴*, the hoods serving to protect the pulleys from the elements. There may also be secured to the arm near its rear end the cross-arm *h* for supporting the line-wires *d*.

The arm and mast are secured together at or near the upper part of the latter by a swivel connection that consists of a pivot *f* having a socket fitting upon the upper end of the mast. On the upper end of this pivot *f* is an annular flange *f'* in which, preferably on diametrically opposite sides, are provided the engaging sockets *f²*. On this pivot *f* is supported the swivel-plate *g* bearing the cheek pieces *g'* on which are located the bearings for the trunnions *b⁶* secured to the arm *b*.

Engaging lugs g^2 are provided preferably on diametrically opposite sides of the swivel-plate and are adapted to embrace the flange f' on the pivot, the outer ends of these engaging lugs underlying the flange. These lugs are of a width to enable them to pass through the engaging sockets f^2 in the flange of the pivot f , said lugs being arranged with reference to the engaging sockets, as to number and position on the swivel-plate. This construction allows the swivel-plate to be placed on the pivot in one position and then swung around and automatically secured against removal; pivoting of the arm b on the swivel-plate allows the outer end of the former to be lowered if necessary by simply disengaging the brace e connecting the outer end of the arm to the mast.

In Fig. 5 of the drawings is shown a modified form of securing the mast and arm together. This consists of a plate 1 secured to the side of the mast as by means of screws or bolts, and projecting outward from this plate, and preferably integral therewith, is the pivot bearing 2. A pivot socket is located in the pivot bearing 2 and in this socket is borne the pivot 3 of the swiveled bearing 4, supporting the cheek-pieces 5 in which are journaled the trunnions 6 secured to the arm b . A pulley 7 is mounted in the lower end of the cheek-pieces, over which passes one of the sections of the lamp adjusting cable. This construction enables the arm to be secured to a mast, as to a tall telegraph pole or the like, on the side thereof, and provides a connection having the advantages set forth in the preceding paragraph.

The cross-arm h is removably secured to the arm b , the latter projecting through a socket in the cross-arm and on the under side of this cross-arm, and preferably integral therewith, is a hood h' in which is mounted the pulley h^2 over which passes a section of the lamp adjusting cable. This cross-arm h is prevented from turning on the arm b as by means of a set screw, or equivalent means. The cross-arm h may be secured in such position that the front edge of the hood (which is made of a proper width) will rest in the engaging socket f^2 located at the rear of the mast, and this construction provides means for securing the arm against any turning movement after it has been located in the desired position.

On the arm b in front of the mast a is adjustably secured a collar i' within which is pivoted the supporting hooks i , the hooks on the lower end of the latter being turned toward the front end of the arm b and located in proper position to engage and support hereinafter described pins located on a hood while the lamp is being lowered to the ground. To the outer end of the arm are pivoted like hooks i^2 turned toward the rear end of the arm and located in such position as to engage the cross piece c' secured to the upper end of the lamp c and bearing the line-wires, this affording a partial support for the lamp in its out-

ward position and relieving part of the strain upon the lamp adjusting cable.

A bracket k is secured to the mast in a position conveniently accessible from the ground, or a short ladder placed against the mast, and bears shaft supports k' . A shaft l is suitably journaled in the shaft supports k' and extending through one end of this shaft is a locking pin l' . A crank l^2 supports on one end a suitable handle as a means of turning, and the other end bears a socket piece l^3 and extending lengthwise through this socket-piece is a hole l^4 for the reception of the shaft l . Engaging slots l^5 are made in each side of the socket-piece extending lengthwise thereof, and at the ends of these engaging slots, and extending crosswise thereof, are locking sockets l^6 . The engaging slots l^5 and the locking sockets l^6 are made of a size to receive the locking pins l' , the handle being placed upon the shaft l in such manner that the locking pins enter the engaging slots until the former rest within the locking sockets, a turn of the handle in either direction securely locking it against removal.

On the shaft l is secured a drum m , this drum having considerable width for the purpose of winding thereon the lamp adjusting cable. On the shaft l is loosely mounted a sleeve n within which is pivoted a link n' , this link having a swinging movement toward and from the drum and being of a size at its upper end to adapt it to enter and engage the locking sockets m' located in the edge of the drum. This link n' is secured to the pulley section of the lamp adjusting cable in such manner that a pull on this section will normally tend to hold the link out of engagement with the locking sockets m' and will pull it out of engagement, when it has been so engaged, upon the unwinding of the section from the drum.

To one end of the shaft l , preferably outside of the shaft support, is secured a double ratchet o the two sets of teeth on which are located side by side and incline in different directions. To the shaft support is pivoted a double gravity pawl o' , this pawl being so constructed that its ends will engage either set of teeth on the ratchets as may be desired.

To the drum m is secured one end of the hoisting section p of the lamp adjusting cable, this section passing upward over the pulley h^2 and over the pulley q' pivoted on the hood q , and to the outer end of the hoisting section p is secured the lamp c . The hood q overcaps the upper part of the pulley q' in such manner as to afford a shield from the weather, and this hood is secured to the outer end of the pulley section r that passes around the pulley b^4 , through the arm b , around the pulley b^3 , and downward where it is secured to the link n' .

It is obvious that the bracket bearing the drum may be located on the front side of the mast if desired, the change of location of the

pulleys to accommodate this position of the drum requiring nothing but the exercise of mere mechanical skill.

The operation of the device is as follows:

5 The lamp being in the lowermost position, shown in dotted outline in Fig. 1 of the drawings, with the pulley section extended and out of engagement with the drum, the turning of the drum in one direction causes the lamp
10 to be carried upward into the upper position, shown in dotted outline in Fig. 1 of the drawings. When the lamp has been hoisted to the desired height the end of the pulley section is forced over to one side so that the link
15 engages one of the locking sockets in the edge of the drum, and then by rotating the shaft in an opposite direction from that required to hoist the lamp the lamp is moved in a direction along the arm to its outer end, as shown
20 in full lines in Fig. 1, the pulley section in this operation being wound upon the drum and the hoisting section being unwound therefrom. In returning the lamp to the ground the drum is rotated in a direction to
25 wind up the hoisting section and to unwind the pulley section, this rotation causing the lamp to be moved horizontally along the arm to a position near the upper end of the mast, and as soon as the lamp has reached this latter
30 position the pulley section at once becomes automatically detached from engagement with the drum and by simply rotating the drum in a reverse direction the lamp is lowered to the ground.

35 It will be seen from this construction that when a lamp has been moved to position at the outer end of the arm the pull of the hoisting section and the pulley section on the drum is equal and the lamp will remain in this position, this pull upon the drum in opposite
40 directions preventing it from rotating, but in order to guard against any accidental rotation of the drum the pawls as described have been provided.

45 This device is capable of use with the arm supported at any height and the arm being of any desired length, the hoisting of the lamp to the desired position depending merely upon the length of the hoisting or pulley section used.

50 With this device the lamp may be brought up closely against the outer end of the arm, or it may be supported under the outer end of the arm at any desired distance therefrom, this distance being determined by the time
55 of engagement of the pulley section with the engaging sockets in the end of the drum.

60 It is obvious that the hoisting section and pulley section may be reversed by simply reversing the devices attached to the outer ends thereof and reversing the method of attachment to the drum and drum supporting shaft and yet embody my invention, the action of the device being practically the same in either
65 instance.

I claim as my invention—

1. In combination, a mast, an arm project-

ing from the mast, a single drum, and a lamp adjusting cable including a hoisting section bearing a lamp and adapted to be wound
70 about the drum, and a pulley section in engagement with the hoisting section and having one end detachably secured to said drum and adapted to be wound thereon, all substantially as described.

2. In combination, a mast, an arm projecting from the mast, a single drum, a lamp adjusting cable including a pulley section detachably secured to said drum and adapted to be wound thereon and also bearing a pulley, and a hoisting section in engagement with the pulley borne by the pulley section and with one end bearing a lamp and the other end secured to said drum and adapted to be wound thereon, and means for rotating
85 the drum, all substantially as described.

3. In an electric lamp support, in combination, a mast, an arm projecting therefrom, a drum, a lamp adjusting cable including a hoisting section with one end secured to said drum, and a pulley section in engagement with the hoisting section, a link secured to the pulley section and adapted to engage locking sockets in said drum, the locking sockets in said drum whereby the pulley section is
95 adapted to be wound about said drum, and means for rotating the drum, all substantially as described.

4. In an electric lamp support, in combination, a mast, an arm projecting therefrom, a drum, a lamp adjusting cable including a hoisting section bearing an electric lamp and with one end secured to said drum, and a pulley section in engagement with the hoisting section, a link secured to the pulley section and pivoted in a sleeve, the sleeve rotarily mounted on the drum shaft supporting said drum, the locking sockets located in said drum and whereby the pulley section is adapted to be wound about said drum, and means for rotating the shaft, all substantially as described.

5. In an electric lamp support, in combination, a mast, an arm projecting therefrom, a lamp adjusting cable supported on the arm and bearing a lamp, engaging pins borne on the cable adjacent to the lamp, a collar adjustably secured to the arm, swinging hooks attached to the collar and adapted to receive the engaging pins on the adjusting cable, and means for moving the cable and lamp along
120 said arm, all substantially as described.

6. In an electric lamp support in combination, a mast, an arm projecting therefrom, a drum, means for rotating the drum, and a lamp adjusting cable including a hoisting section bearing an electric lamp with one end secured to the drum, and a pulley section with one end in engagement with the hoisting section and its opposite end automatically detachably secured to the drum, all substantially as described.

7. In an electric lamp support in combination, a mast, a pivot supported on the upper end of the mast, a circular flange on the pivot,

a swivel plate, engaging lugs borne on the plate with their ends underlying the flange on the pivot, an arm pivoted on the swivel plate, and means for supporting and moving
5 an electric lamp along the arm and mast, all substantially as described.

8. In an electric lamp support in combination, a mast, a pivot secured to the upper end of the mast, a circular flange located about
10 the end of the pivot, the engaging sockets located in the edge of the flange, a swivel plate borne on the pivot, the engaging lugs on the swivel plate adapted to enter the engaging sockets and their ends adapted to underlie
15 the flange, the arm secured to the swivel plate, and means for supporting and moving an electric lamp along the arm and mast, all substantially as described.

9. In an electric lamp support in combination, a mast, a pivot supported on its upper
20 end, the circular flange located on the pivot, engaging sockets located in the flange, a swivel plate borne on the pivot, engaging lugs adapted to enter the sockets and to extend
25 underneath the flange, an arm secured to the swivel plate, a cross arm adjustably secured to said arm, a hood on the cross arm adapted to enter the engaging slots in the pivot, and means for supporting and moving an electric
30 lamp along the arm and mast, all substantially as described.

JAMES J. RENEHAN.

Witnesses:

ARTHUR B. JENKINS,
JOSEPH ARTHUR CANTIN.