

(No Model.)

3 Sheets—Sheet 1.

W. L. BARRELL.
SOLE LEVELING MACHINE.

No. 522,776.

Patented July 10, 1894.

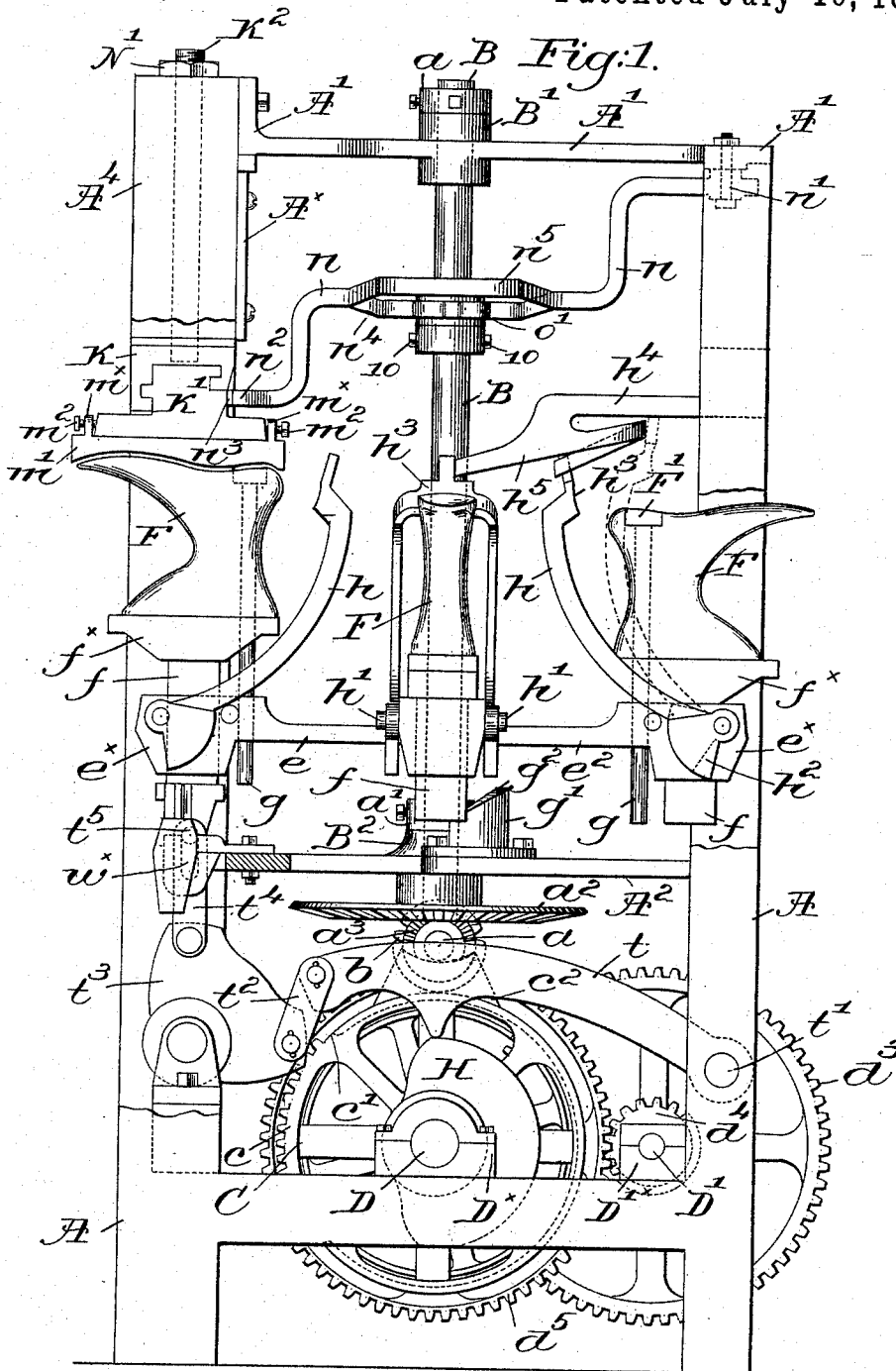

Witnesses.
Fred S. Gumbel
Louis W. Howell

Inventor:
William L. Barrell,
by Crosby & Gregory
attys.

W. L. BARRELL.
SOLE LEVELING MACHINE.

No. 522,776.

Patented July 10, 1894.

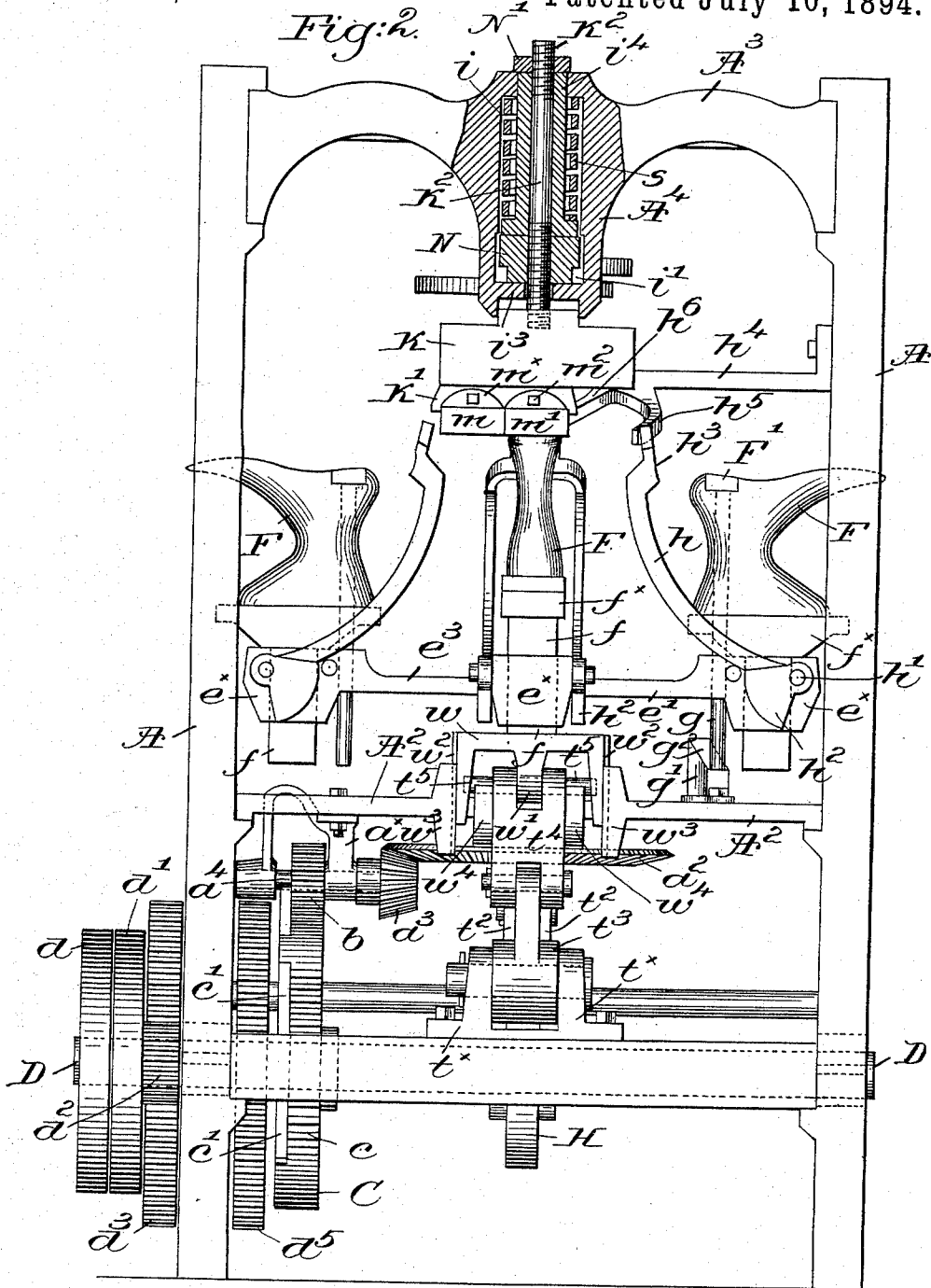

Witnesses.

Laus N. Howell
Fred S. Grumbaf.

Inventor:
William L. Barrell.
by Crosby & Gregory
attys.

(No Model.)

3 Sheets—Sheet 3.

W. L. BARRELL.
SOLE LEVELING MACHINE.

No. 522,776.

Patented July 10, 1894.

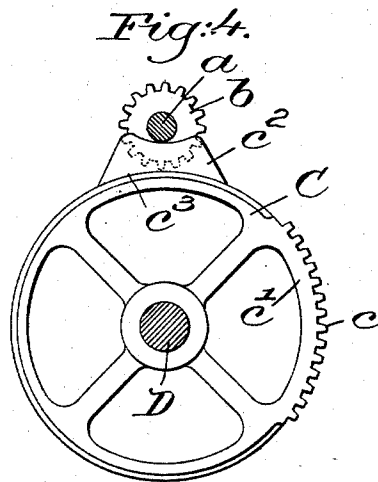
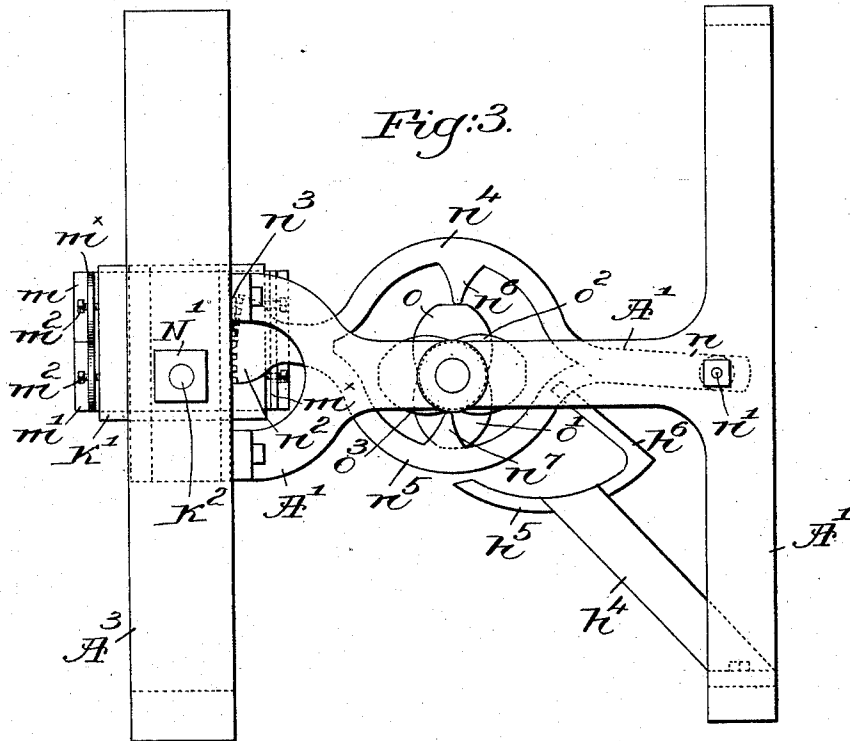

Witnesses.

Fred S. Grumbaf
Louis McBowell

Inventor:

William L. Barrell.
by Crosby & Gregory
attys

UNITED STATES PATENT OFFICE.

WILLIAM L. BARRELL, OF LAWRENCE, MASSACHUSETTS.

SOLE-LEVELING MACHINE.

SPECIFICATION forming part of Letters Patent No. 522,776, dated July 10, 1894.

Application filed August 23, 1893. Serial No. 484,170. (No model.)

To all whom it may concern:

Be it known that I, WILLIAM L. BARRELL, of Lawrence, county of Essex, State of Massachusetts, have invented an Improvement in Sole-Leveling Machines, of which the following description, in connection with the accompanying drawings, is a specification, like letters on the drawings representing like parts.

10 This invention has for its object the production of a machine to level or shape the sole of a shoe, in the process of manufacture, by placing the shoe upon a support and thereafter compressing the sole between said support and a "former" of suitable shape and construction.

15 In apparatus of this class known to me the shoe is placed upon a support by the operator, and after the sole has been leveled the operator removes the shoe preparatory to placing another shoe thereon, such removal requiring considerable force and the use of both hands, so that unnecessary time is consumed in making the change.

20 My invention is so constructed that a series of supports are successively brought into position to co-operate with the "former," said supports being preferably arranged for rights and lefts alternately, the "former" for each being automatically brought into position to co-operate with its particular support, means being provided to act upon the interior of the shoe to raise it from the support when leveled, and to push it partially off, so that the operator can readily remove it with one hand.

25 In accordance therewith my invention consists, in a sole leveling machine, of the following instrumentalities, viz:—a last upon which is fitted the shoe the sole of which is to be leveled, a support for said last, a "former" to co-operate with the sole of the last to shape the sole of the shoe carried thereby, means to change the relative positions of said "former" and last, to compress the shoe sole between them, a normally retracted ejector located in the heel end of the last, and an actuator to move the ejector into abnormal position to act upon the interior of and slightly raise the heel end of the leveled sole from the heel of the last, substantially as will be described.

30 Other features of my invention will be here-

inafter described and particularly pointed out in the claims.

Figure 1 is a side elevation, partially broken out, of a sole leveling machine embodying my invention. Fig. 2 is a rear view thereof, and partially in section. Fig. 3 is a detail of the mechanism for controlling the "formers," and Fig. 4 is a detail to be referred to.

60 The frame A of suitable shape to support the operative parts of the machine, is provided with upper and intermediate braces A' and A², see Fig. 1, having bearings B', B² respectively, for a vertical shaft B, said shaft being held in place by suitable collars *a* and *a'* thereon, which rest on the tops of the bearings and sustain the weight of the shaft and parts secured thereto.

65 Below the brace A² the hub of a bevel gear *a*² is secured to the shaft B, said gear engaging a smaller gear *a*³, see Figs. 1 and 2, fast on a short shaft *a*⁴ supported in a bracket or hanger *a*^x secured to the brace A², as herein shown. A pinion *b* is also fast on the shaft *a*⁴ to be engaged and rotated intermittingly by a segment gear C fast on the main or driving shaft D.

70 The teeth *c* on the segment gear C are located upon one quarter of its circumference only, see Fig. 4, and sufficient in number to rotate the pinion *b* once, the bevel gears *a*² and *a*³ being of such relative size that one complete revolution of the latter gear will turn the former through one-quarter of a revolution, and the attached shaft B a similar distance.

75 As will hereinafter appear, it is necessary to hold the shaft from rotation during the time that the segment gear C is revolving, after the teeth *c* thereon are disengaged from the pinion *b*, and I use a locking device shown in Figs. 1 and 2, and separately in Fig. 4.

80 Referring to said figures the periphery of the segment gear C is smooth with the exception of the toothed portion *c*, and opposite said teeth, and slightly beyond the end ones, the periphery is cut away, as at *c'*.

85 An escapement, shown as a block or shoe *c*², is secured at one side to or movable with the pinion *b*, and in the plane of the cut away portion *c'* of gear C, the face *c*³ of the shoe having the same curvature as the smooth periphery of the segment gear, and extending 90 95 100

beyond the pinion b on each side, as best shown in Fig. 4.

When the first tooth of the series c engages the pinion b and turns the same, the block or shoe c^2 is also turned, and as the rotation of the gear and pinion continues the block c^2 slides off from the periphery of the gear and enters the cut away portion c' , thereby permitting said block to turn with the pinion. As the last tooth of the series c leaves the pinion b the adjacent end of the cut away portion is below the center of the block c^2 , about half of the face of the latter then resting on the smooth periphery of the gear C , and forms a rest therefor, holding it and the pinion b firmly against rotation until the teeth c are again brought into engagement with the pinion.

It will be seen that in consequence the shaft B is given a quarter rotation, then locked or held from rotation, then given another quarter rotation, and so on.

The main or driving shaft D has loose thereon belt pulleys d, d' , see Fig. 2, the pulley d' having secured thereto a pinion d^2 , and also loose upon the shaft D . This pinion d^2 engages a large gear d^3 on an auxiliary shaft D' , see Fig. 1, and a pinion d^4 fast thereon engages a gear d^5 secured to the driving shaft D to rotate the same, whereby the speed of the driving shaft is reduced without reducing the speed of the driving belt.

Any usual belt shifter may be employed to shift the belt, not shown, from one to the other of the pulleys d, d' , to stop or start the machine.

Suitable bearings D^x and D'^x support the shafts D and D' respectively, the bearings at one side of the apparatus being shown in Fig. 1.

A carrier is secured to and to be rotated by the shaft B , said carrier as herein shown consisting of a series of like arms e, e', e^2 and e^3 radiating from the shaft, and enlarged at or near their extremities to form like guides or supports e^x for the depending portions f of the bases f^x of a series of shoe supports F , the portions f being preferably polygonal in cross section, to prevent rotation thereof in the correspondingly shaped guides e^x .

Inasmuch as the shaft B is turned one quarter of a revolution at a time the arms of the carrier are shown as four in number, to present one support to the "former" at each movement of the shaft, as will be described.

The shoe supports F are shaped to receive the shoe snugly thereon, and the bases f^x are extended to firmly sustain the supports, and preferably the supports are arranged alternately for right and left shoes, the supports carried by the arms e and e^2 , for instance, being rights, while those carried by arms e' and e^3 are lefts. Each such support is provided with an ejector F' , herein shown as a movable block located at the heel portion and normally flush with the support, the ejector having a shank g extended loosely through the

support, and through a suitable opening in the guide e^x , and below the same, as shown in Figs. 1 and 2.

A block g' having an inclined upper face g^2 , and secured to the brace A^2 , in the path of the depending shanks, as they are moved by the shaft B , forms a lifting mechanism or actuator to raise the ejectors one by one as the shanks thereof engage and are raised by the inclined face g^2 .

In Fig. 2 the shank depending from the support carried by the arm e' is just about to be lifted by the face of the block g' , such movement of the ejector acting upon the interior of a shoe upon the support to raise the rear portion thereof from said support, to be thereafter acted upon by mechanism to be described.

A knock-off is herein shown as adapted to co-operate with each ejector, consisting of a yoke h pivotally connected to each guide e^x at h' and provided with a counterbalance h^2 to normally retain the yoke in retracted or inoperative position, as shown in the drawings, the upper end of the yoke being preferably slightly concave, as at h^3 , to bear against the back of the shoe counter when raised from the support by the ejector, and thereby push the shoe partially off of said support, so that the operator can with one hand and little effort remove the shoe therefrom, preparatory to putting another on to be manipulated.

A bracket or suitable support h^4 is secured to the frame, and has thereon a cam provided with a curved surface h^5 and a straight surface h^6 , see Figs. 1, 2 and 3.

The cam surface is located in the path of movement of the upper ends of the yokes h , the curved surface h^5 engaging and gradually moving the yoke forward until the dotted line position shown in Fig. 1, is reached, the shoe, not shown, at such time having been pushed partially off from the support.

As soon as the continued movement of the carrier takes the yoke beyond the face h^5 of the cam, said yoke is quickly drawn back by the counterbalance h^2 to its former position, the straight face h^6 of the cam permitting such movement to take place.

The rear side of the machine is provided at the top with a strong cross brace A^3 , see Figs. 1, 2 and 3, having a central head A^4 , cored out at i and i' , see Fig. 2, to leave a guide or bearing i^3 , the head A^4 below the same being recessed and of square or other than round cross section, to receive therein and guide the upper part of a block k which supports the holder k' for the "formers." Access to the interior of the head A^4 is had through an opening at its inner side, normally closed by a cover plate A^x , see Fig. 1, and the top of the head has an opening therein to receive the end of a sleeve i^4 flanged at its lower end. The cover A^x being removed, the sleeve i^4 , surrounded by a strong spring s , is inserted in the cored out portion i , the upper end of the sleeve entering the opening at the top of

the head, while an internally threaded nut N is inserted in the cored portion i' , resting upon the guide i^3 and supporting the sleeve i^4 , said portion i' being uncovered at the outer side of the head, that access may be had to said nut N.

When the above described parts have been put in position a threaded rod k^2 , secured in any suitable manner to the block k , is extended loosely through the guide i^3 and in engagement with the nut N, the latter being rotated upon the rod as it is moved through the sleeve i^4 , until in substantially the position shown in Figs. 1 and 2, when a retaining nut N' is screwed upon the projecting end of the rod, said nut extending beyond the end of the sleeve and resting upon the head, to hold the block k in position. The block, and hence the "formers" carried thereby, are supported in a yielding manner in the head by the spring s , the nut N acting as a set nut to keep the spring and sleeve in place.

By raising or lowering the rod k^2 in the retaining nut N' the amount of pressure to be exerted upon the soles to be leveled is decreased or increased, it being of course understood that in making such adjustments the set nut N will be correspondingly moved upon the rod to maintain the sleeve and spring in proper position.

As best shown in Fig. 1, the block k is grooved upon its under side longitudinally to receive the holder k' , dovetailed to fit and be held therein, and yet adapted to slide longitudinally in said block.

The "formers," herein shown as side by side and two in number, m and m' , are provided with ears m^x through which retaining screws m^2 extend to bear against the inclined front and rear faces of the holder k' , whereby the "formers" can be readily applied or removed. One of the "formers" is shaped upon its face to level the sole of a right shoe, and the other is shaped to level the sole of the left shoe, and they are adapted to be brought into position at the center of the block k alternately, by means of a cam actuated lever n , pivoted to the brace A' at n' , and provided at its free end with a toothed segment n^2 , engaging rack teeth n^3 on the inner face of the holder k' , oscillation of the lever moving said holder and the "formers" back and forth in the block k , bringing the "formers" alternately to the center thereof.

The lever n is bent, as shown in Fig. 1, and as best shown in Figs. 1 and 3 is enlarged at its central portion to surround the shaft B, the opposite sides n^4 and n^5 being in different horizontal planes, and provided with inturned projections n^6 and n^7 respectively, adapted to be acted upon by cams o , o' , and o^2 , o^3 secured to the shaft B by set screws 10, or in any desired manner. The cams o and o' are in the same horizontal plane as the projection n^6 and diametrically opposite each other, while the cams o^2 and o^3 are also diametrically opposite each other, but at right angles to o

and o' , and in the horizontal plane of the projection n^7 .

By an inspection of Fig. 3 it will be seen that each quarter revolution of the shaft B will bring one of the cams of a pair into engagement with one of the projections on the lever n , the other projection at such time being intermediate its pair of actuating cams and at the neutral point, so that for every quarter revolution of the shaft B the lever n will be moved to one or the other side, reciprocating the holder k' in the block k , to bring first one and then the other of the "formers" m , m' into operative position. This movement brings the right and left "formers" alternately into operative position, the alternate arrangement of the right and left shoes supports F bringing the proper one into position to cooperate with the corresponding "former," so that the operator, standing at the right hand of the machine, viewing Fig. 1, will place, say, a right shoe on the support carried by arm e^2 , and a left shoe on the support carried by arm e' , as it comes in front of him by the rotation of the carrier, after removing the partially displaced shoe which has been operated upon, and continue the operation.

It now remains to describe the mechanism for raising each support successively against one of the "formers," to compress the sole of the supported shoe.

The shaft D has a cam H secured thereto, see Figs. 1 and 2, to actuate a lever t pivoted at t' to the main frame, the free end of said lever being pivotally connected by a link t^2 to the arm of a bell crank lever t^3 , journaled in a bearing t^x secured to the frame, the other arm of said lever t^3 forming, with a link t^4 pivoted thereto, a toggle joint, the other end of the link being pivotally connected by a laterally extended pin t^5 to a depending lug w' formed on the under side of a slide block w having a flat upper face, and slides w^2 to enter and be guided by suitable ways w^3 , secured to or forming a part of the brace A^2 . Additional ways w^4 are also provided, having recesses w^x therein, see dotted lines Fig. 1, to receive and guide the laterally projecting ends of the pin t^5 .

The shape of the cam H is such that the lever t is at its lower position and the toggle bent during the partial revolution of the carrier on the shaft B, the upper face of the slide block w at such time being below the ends of the depending portions f of the shoe support, and as shown in Fig. 2, the center of said slide block, and the center line of the toggle are in the same vertical plane as the axis of the rod k^2 , immediately below the co-operative position of the "formers."

When the partial revolution of the shaft B has brought one of the supports F beneath the "former," and is held there as described, the high part of the cam H raises the lever t , straightening the toggle and forcing the slide block w up against the end of the depending portion f of the support, and thereby moving

the support vertically in its bearing e^x until the sole of the shoe thereon is brought against the "former," compressing and shaping it, the pressure being regulated by the nuts N and N', as has been described, inasmuch as the slide block has a constant throw. Before the carrier is again moved the toggle is bent and the support F lowered, the slide block remaining at rest until the next support is moved into position thereover.

In the operation of the machine, a shoe will be removed by the operator from the support or arm e^2 , for instance, and a new one will be placed thereon while the shoe on the support in arm e is being leveled, after which the partial revolution of the carrier will bring arm e' in front of the operator, the arm e^3 then being in position to compress the sole of the shoe in its support. After compression the next step brings the shoe into position to be raised from its support by the ejector F' acting upon its interior, and the next step brings it in front of the operator to be removed, the knock-off described pushing the shoe partially off just prior to the last named position in front of the operator.

Much time is saved by the apparatus herein described as the operator can remove a shoe with one hand while preparing to put another on the support, the pairs are not separated, and the employment of a skilled operator is unnecessary, as the greater part of the operation is automatic.

My invention is not restricted to the specific construction and arrangement of parts as herein described and shown, as it is obvious they may be modified or altered in various ways without departing from the spirit of my invention.

While I have herein shown the carrier as provided with means for sustaining four shoe supports, it is evident that a different number might be used by correspondingly altering the driving mechanism.

I claim—

1. In a sole leveling machine, the following instrumentalities, viz:—a last upon which is fitted the shoe the sole of which is to be leveled, a support for said last, a "former" to co-operate with the sole of the last to shape the sole of the shoe carried thereby, means to change the relative positions of said "former" and last, to compress the shoe sole between them, a normally retracted ejector located in the heel end of the last, and an actuator to move the ejector into abnormal position to act upon the interior of and slightly raise the heel end of the leveled sole from the heel of the last, substantially as described.

2. In a sole leveling machine, the following instrumentalities, viz:—a "former," a rotatable carrier, a series of lasts thereon upon which are fitted the shoes the soles of which are to be leveled, an ejector for each last adapted to act upon the interior of and to

slightly raise the heel end of the leveled sole from the heel end of the last, actuating mechanism for and to automatically rotate the carrier intermittingly to bring the lasts one by one into co-operative position relative to said "former" to compress the sole of the shoe upon said last, and a cam in the path of movement of and to actuate each ejector in turn, substantially as described.

3. In a sole leveling machine, a "former," a rotatable carrier, and a series of vertically movable shoe supports having depending portions extended through and below said carrier, combined with actuating mechanism for and to automatically rotate the carrier step by step to bring the supports successively into position to co-operate with the "former," and mechanism, including a vertically sliding block, in the path of movement of and to act upon the depending portions of the shoe supports one by one, to move the co-operating support toward the "former," to compress the sole there-between, substantially as described.

4. In a sole leveling machine, a "former," a rotatable carrier, a series of shoe receiving supports thereon, an ejector for each support provided with a depending shank, actuating mechanism for and to automatically rotate the carrier to bring the supports successively into position to co-operate with said "former," and a locking device controlled by the actuating mechanism to stop the movement of the carrier when a support is in operative position, combined with an actuator in the path of movement of the ejector shanks, to lift them and thereby cause the ejector to act against and raise the shoe from the support after leaving the "former," substantially as described.

5. In a sole leveling machine, the combination with a "former," of a shoe support, means to move one toward the other to compress the sole, an ejector to act upon the interior of the shoe and raise it from the support, and a knocking-off device to thereafter push the shoe partially or entirely from the support, substantially as described.

6. In a sole leveling machine, a "former," a shoe support adapted to be moved toward it to compress a sole, an ejector for said support, normally retracted to be flush therewith, and a pivotally supported knock-off, combined with means to move the ejector against the interior of and raise a shoe from the support, and a cam to actuate the knock-off and cause it to push the shoe partially from the support, substantially as described.

In testimony whereof I have signed my name to this specification in the presence of two subscribing witnesses.

WILLIAM L. BARRELL.

Witnesses:

JOHN C. EDWARDS,
FREDERICK L. EMERY.