



US00D838212S

(12) **United States Design Patent**  
**David**

(10) **Patent No.:** **US D838,212 S**  
(45) **Date of Patent:** **\*\* Jan. 15, 2019**

(54) **MOTOR SCOOTER**  
(71) Applicant: **UJET VEHICLES S.à r.l., Bertrange (LU)**  
(72) Inventor: **Patrick David, Blaustein (DE)**  
(73) Assignee: **UJET VEHICLES S.à r.l., Bertrange (LU)**

D490,750 S \* 6/2004 Hoshino ..... D12/110  
D503,907 S \* 4/2005 Beggio ..... D12/110  
D514,987 S \* 2/2006 Hsiao ..... D12/110  
D529,415 S \* 10/2006 Shimada ..... D12/110  
D537,386 S \* 2/2007 Mizuta ..... D12/110  
D537,756 S \* 3/2007 Kitayama ..... D12/110  
D574,300 S \* 8/2008 Kitayama ..... D12/110  
D585,334 S \* 1/2009 Chiu ..... D12/110  
D596,992 S \* 7/2009 Yang ..... D12/110

(Continued)

(\*\*) Term: **15 Years**

*Primary Examiner* — Darlington Ly

(21) Appl. No.: **29/605,526**

(74) *Attorney, Agent, or Firm* — Marshall, Gerstein & Borun LLP

(22) Filed: **May 26, 2017**

(57) **CLAIM**

(30) **Foreign Application Priority Data**

The ornamental design for a motor scooter, as shown and described.

Nov. 28, 2016 (EP) ..... 003490192

**DESCRIPTION**

(51) **LOC (11) CL.** ..... **12-11**

(52) **U.S. CL.**  
USPC ..... **D12/110**

(58) **Field of Classification Search**  
USPC ..... D12/110, 111, 117; D21/432, 538  
CPC ..... B62K 11/00; B62K 11/02; B62K 11/04;  
B62K 11/10; B62K 17/00; B62K 19/00;  
B62K 2202/00

FIG. 1 is a top, front, and left perspective view of a motor scooter showing my new design in accordance with a first embodiment;  
FIG. 2 is a front elevation view thereof;  
FIG. 3 is a rear elevation view thereof;  
FIG. 4 is a left side elevation view thereof;  
FIG. 5 is a right side elevation view thereof;  
FIG. 6 is a top plan view thereof;  
FIG. 7 is a bottom plan view thereof;  
FIG. 8 is a top, front, and left perspective view of a motor scooter showing my new design in accordance with a second embodiment;  
FIG. 9 is a front elevation view thereof;  
FIG. 10 is a rear elevation view thereof;  
FIG. 11 is a left side elevation view thereof;  
FIG. 12 is a right side elevation view thereof;  
FIG. 13 is a top plan view thereof; and,  
FIG. 14 is a bottom plan view thereof.  
The broken lines in the drawings illustrate portions of the motor scooter that form no part of the claimed design.

See application file for complete search history.

(56) **References Cited**

**U.S. PATENT DOCUMENTS**

D269,169 S \* 5/1983 Ban ..... D12/110  
D270,436 S \* 9/1983 Gaddi ..... 296/37.12  
D273,853 S \* 5/1984 Kawashima ..... D12/110  
D286,521 S \* 11/1986 Tanaka ..... D12/110  
D287,833 S \* 1/1987 Moselli ..... D12/110  
D287,834 S \* 1/1987 Ito ..... D12/110  
D290,824 S \* 7/1987 Miura ..... D12/110  
4,715,465 A \* 12/1987 Takahashi ..... B62J 17/00  
180/219  
D304,555 S \* 11/1989 Nishiyama ..... D12/110  
D331,553 S \* 12/1992 Agnolucci ..... D12/110

**1 Claim, 14 Drawing Sheets**

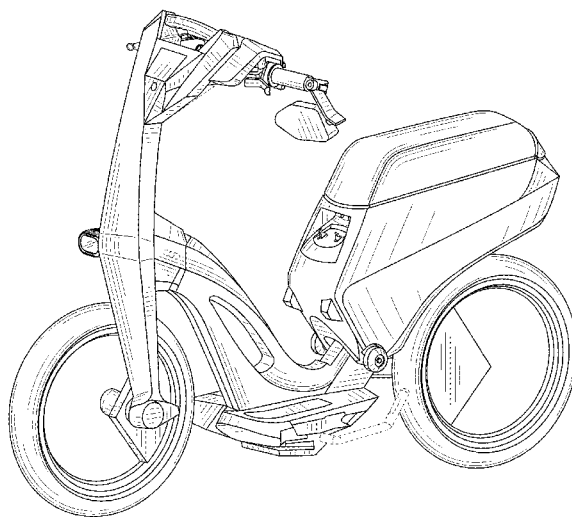

(56)

**References Cited**

## U.S. PATENT DOCUMENTS

D602,813	S *	10/2009	Chao	.....	D12/110
D602,815	S *	10/2009	Lin	.....	D12/110
D612,770	S *	3/2010	Chen	.....	D12/110
D622,637	S *	8/2010	Schneider	.....	D12/110
D642,497	S *	8/2011	Lin	.....	D12/110
D644,961	S *	9/2011	Watanabe	.....	D12/110
D647,006	S *	10/2011	Hung	.....	D12/110
D657,722	S *	4/2012	Lambri	.....	D12/110
D664,898	S *	8/2012	Van Hooydonk	.....	D12/110
D673,882	S *	1/2013	Tartarini	.....	D12/110
D678,128	S *	3/2013	Lambri	.....	D12/110
D680,911	S *	4/2013	Wu	.....	D12/110
D690,235	S *	9/2013	Wu	.....	D12/110
D727,799	S *	4/2015	Castrucci	.....	D12/110
D729,124	S *	5/2015	Lambri	.....	D12/110
D735,084	S *	7/2015	Lambri	.....	D12/110
9,073,594	B2	7/2015	Sluijter et al.		
D742,791	S *	11/2015	Sanderson	.....	D12/110
D761,699	S *	7/2016	Watanabe	.....	D12/110
9,463,843	B2 *	10/2016	Tseng	.....	B62J 1/00
D806,610	S *	1/2018	Su	.....	D12/110

\* cited by examiner

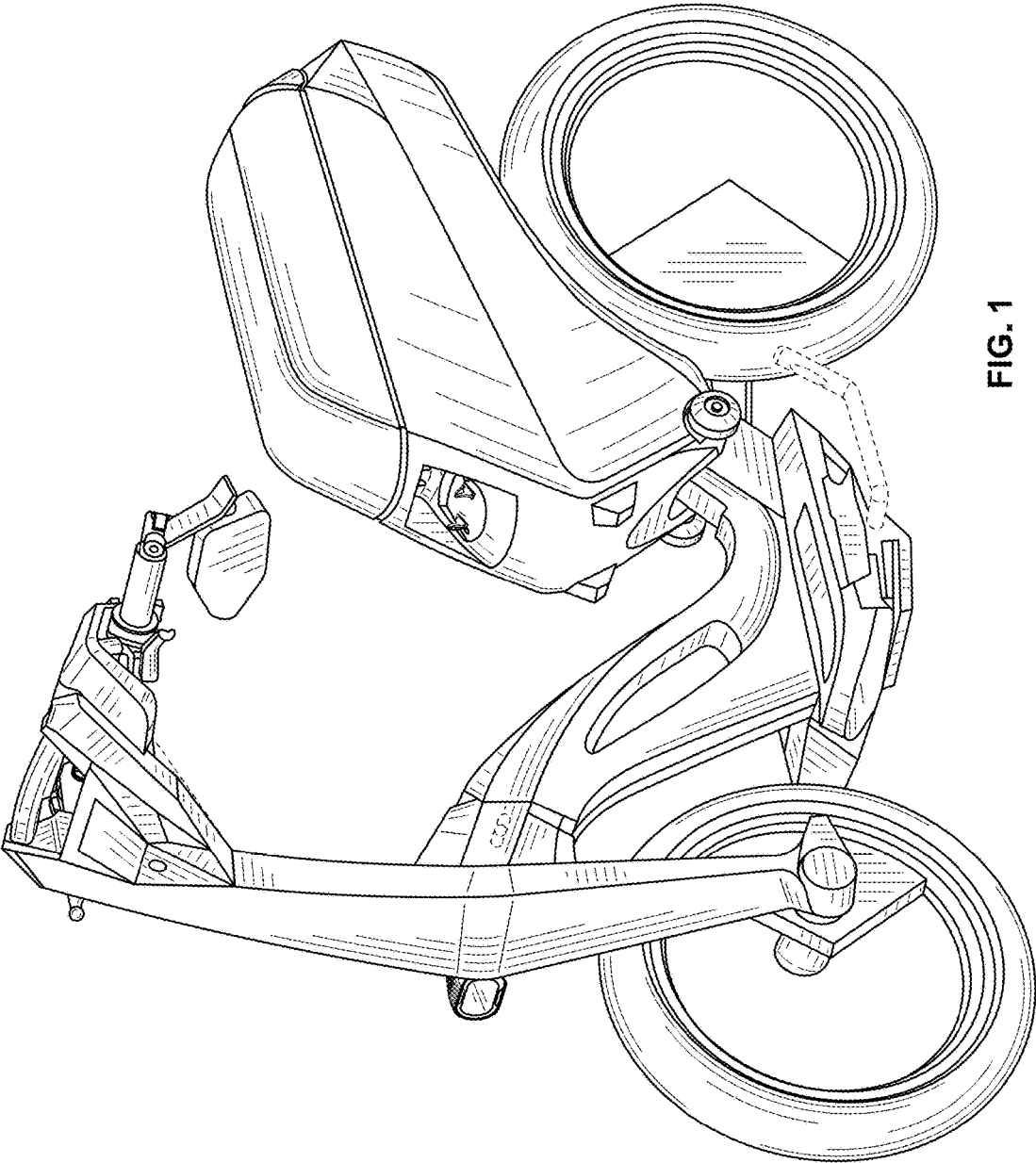

FIG. 1

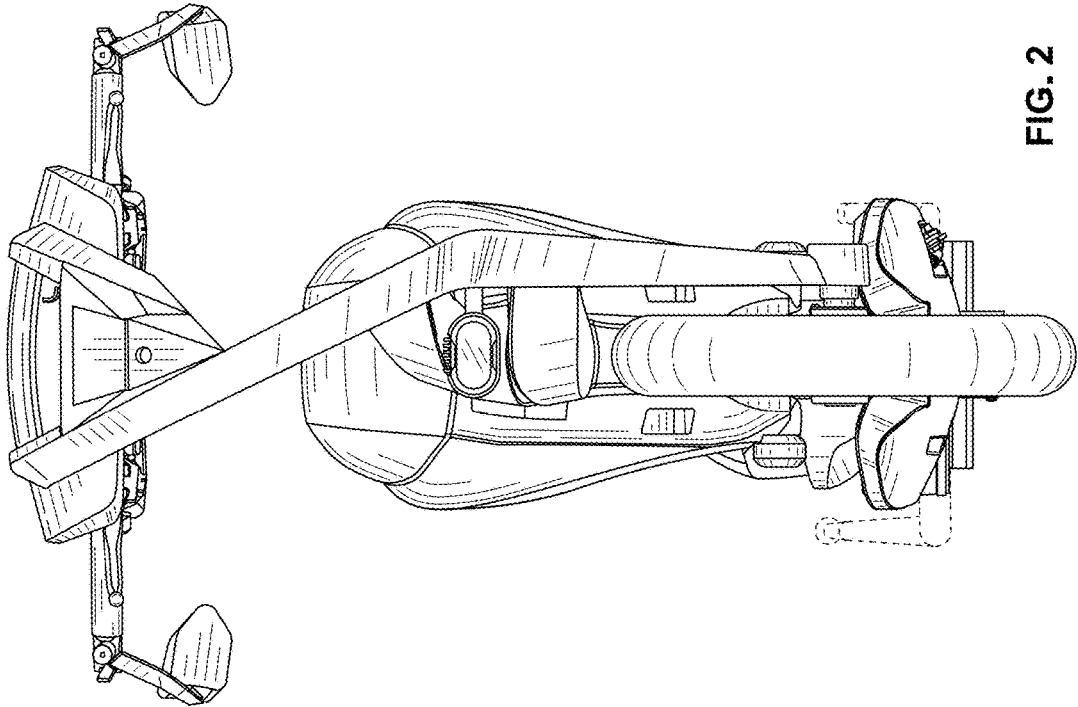

FIG. 2

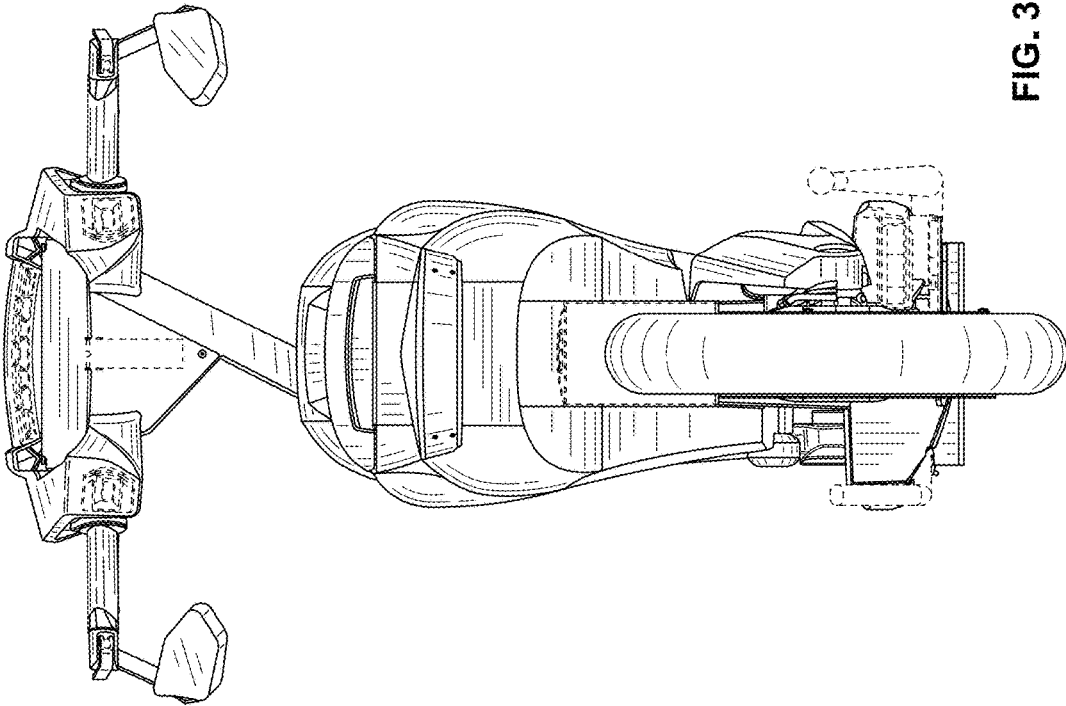

FIG. 3

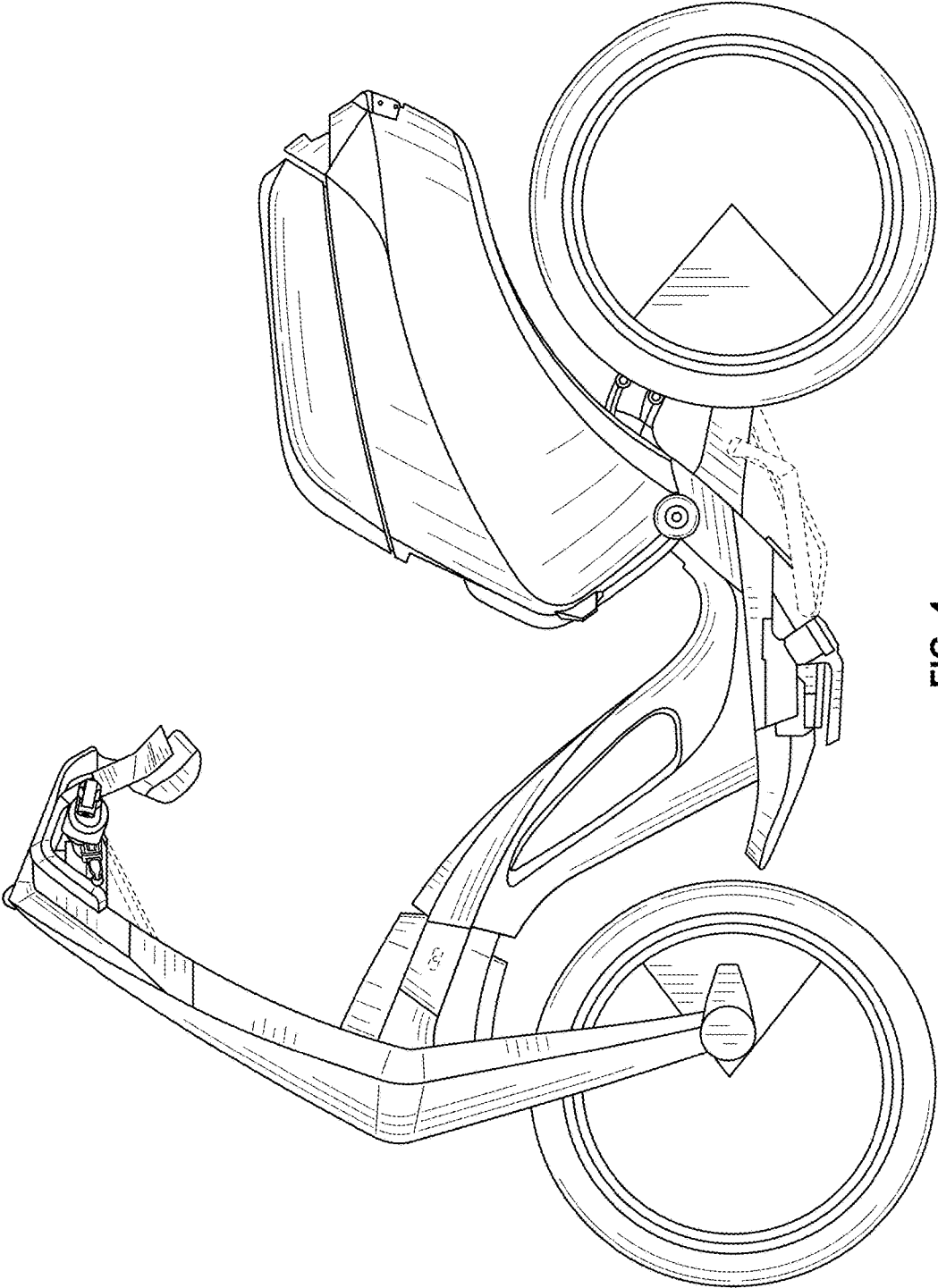

FIG. 4

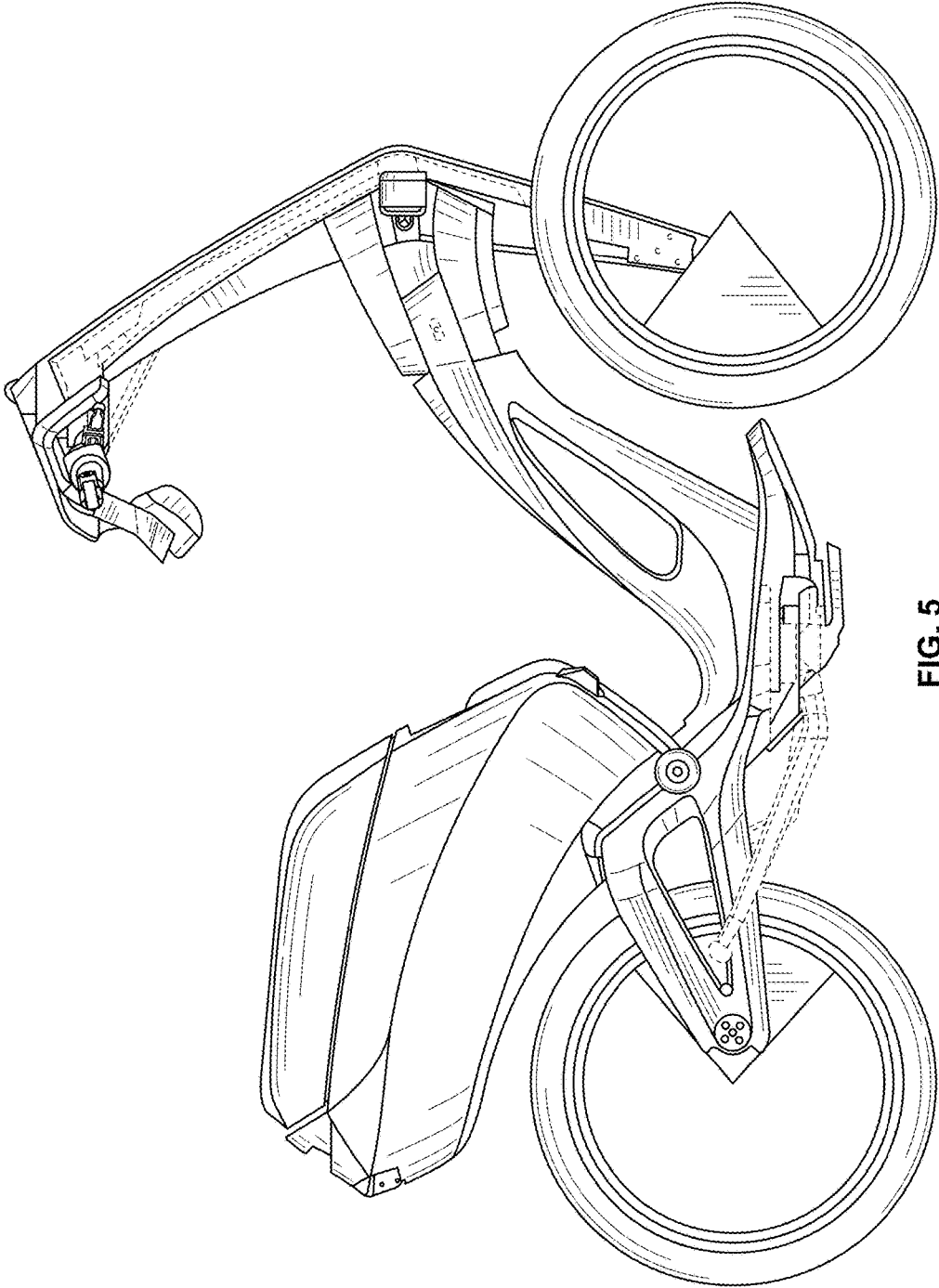

FIG. 5

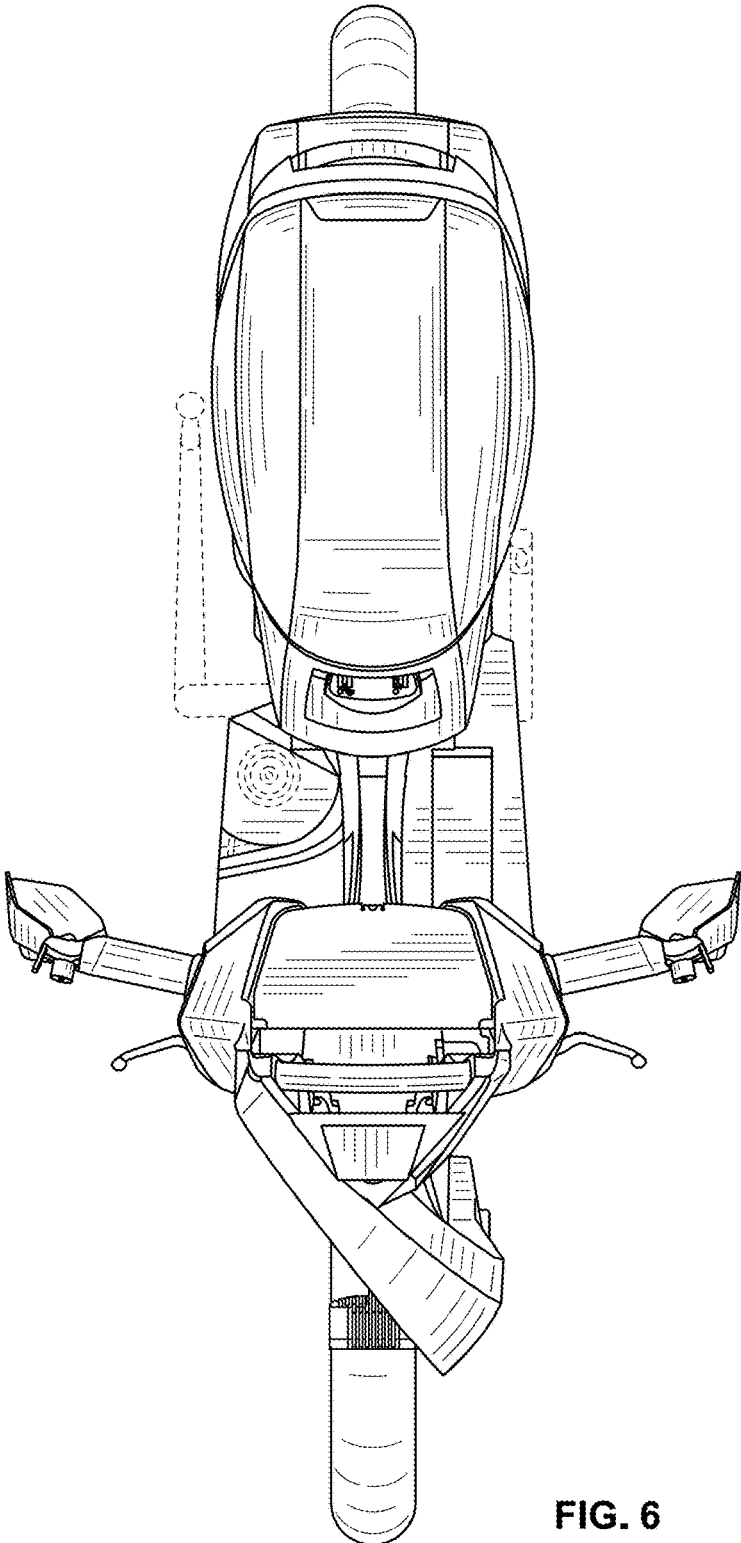

FIG. 6



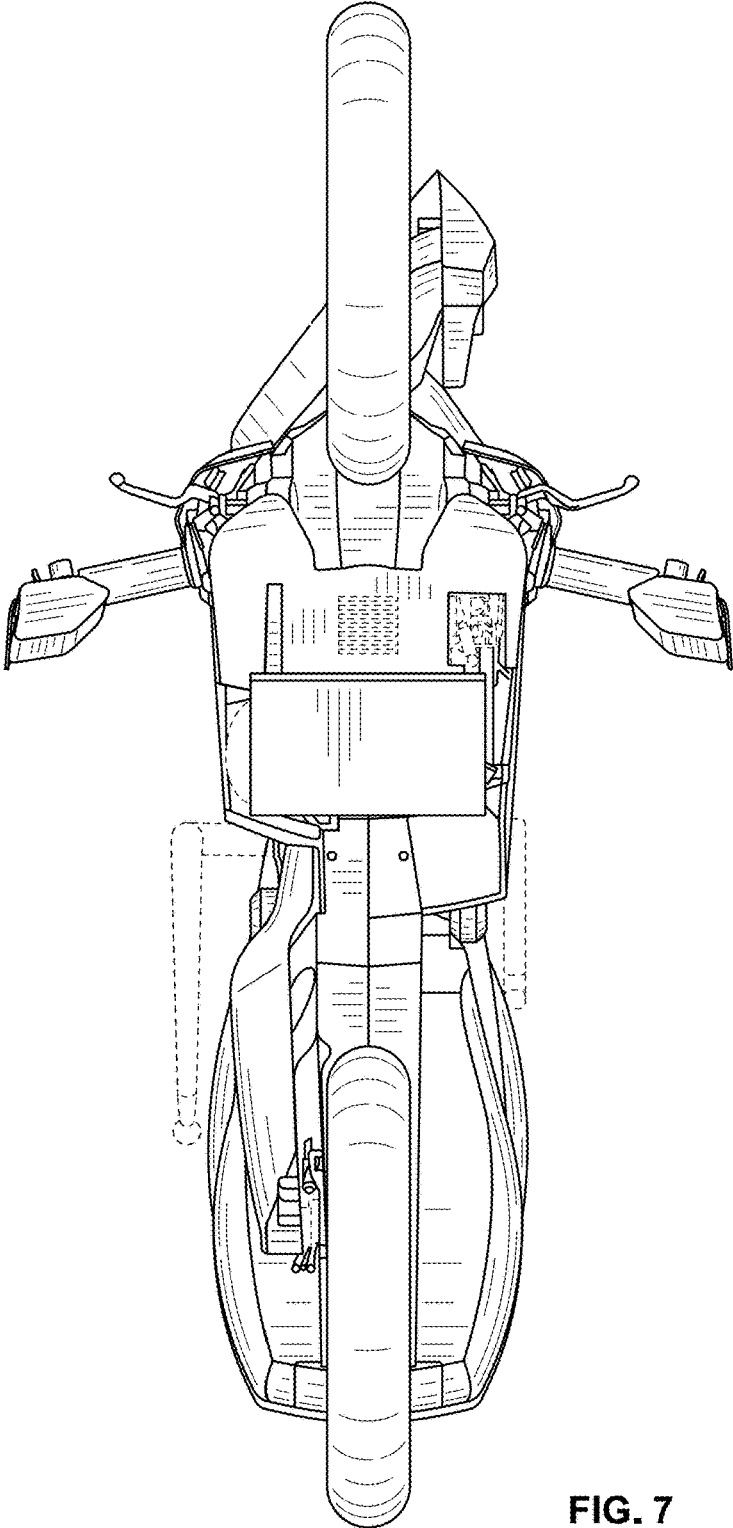

FIG. 7

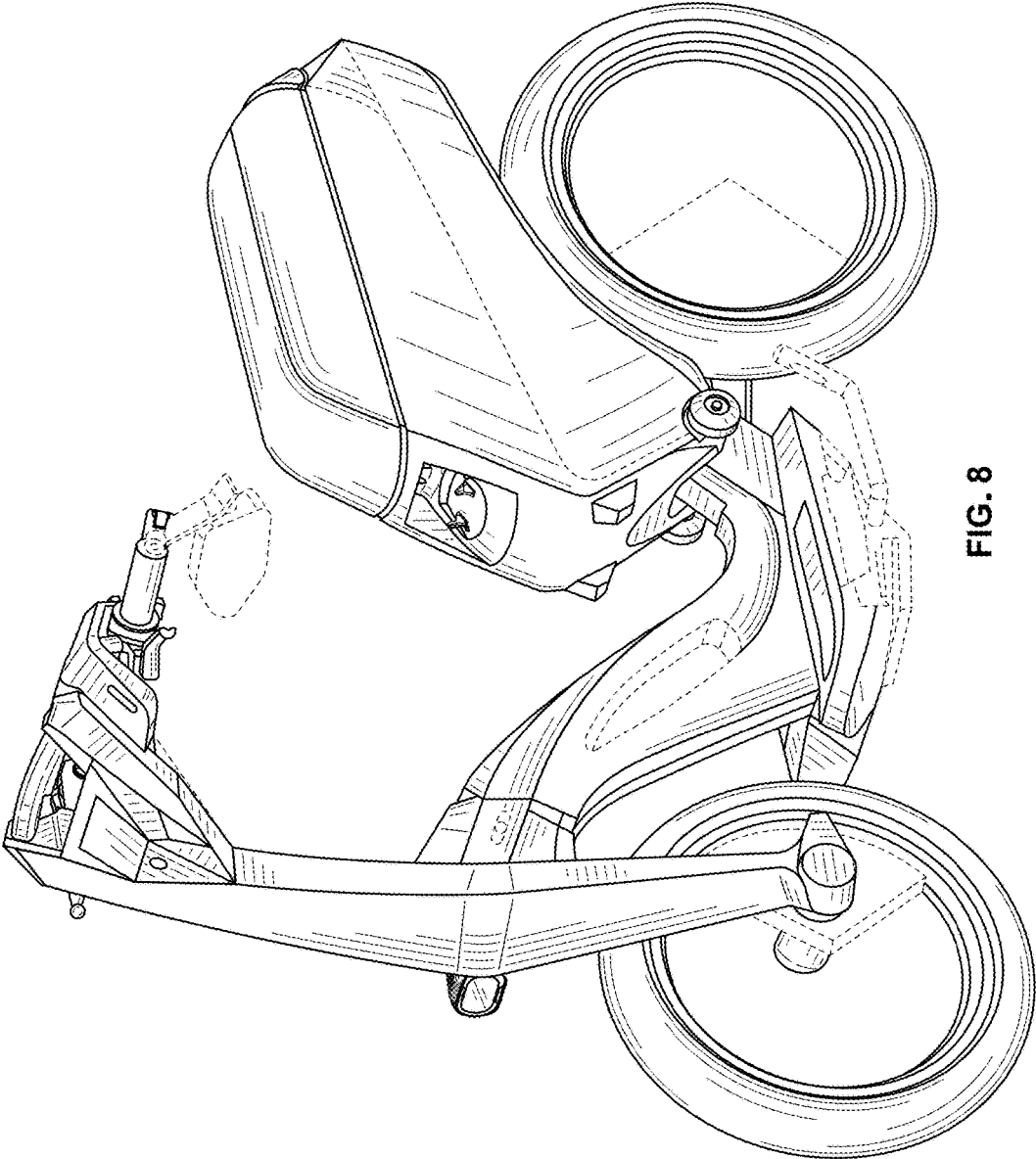

FIG. 8

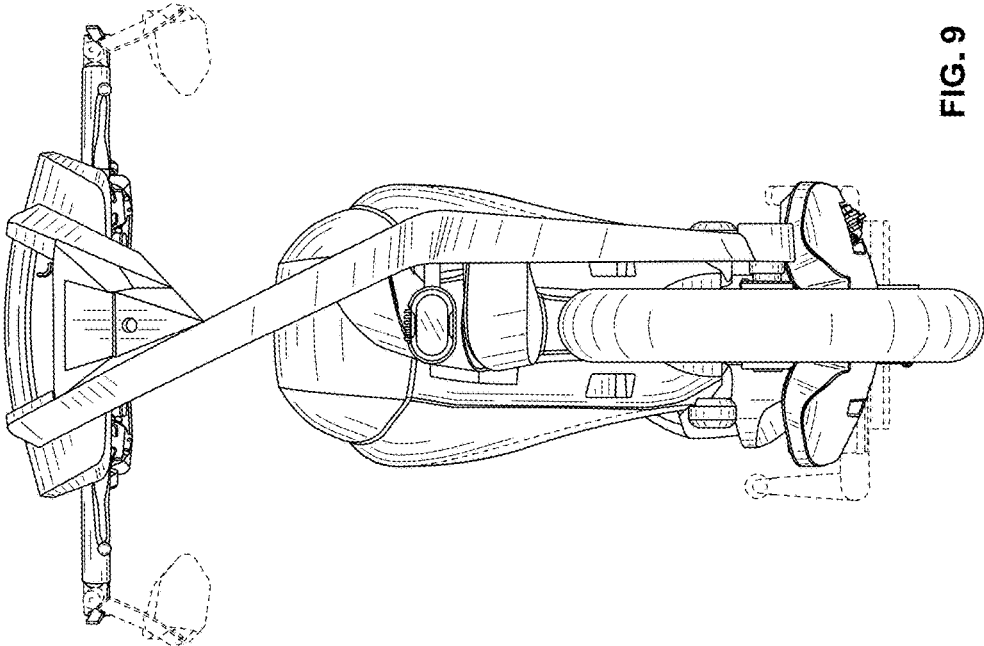

FIG. 9

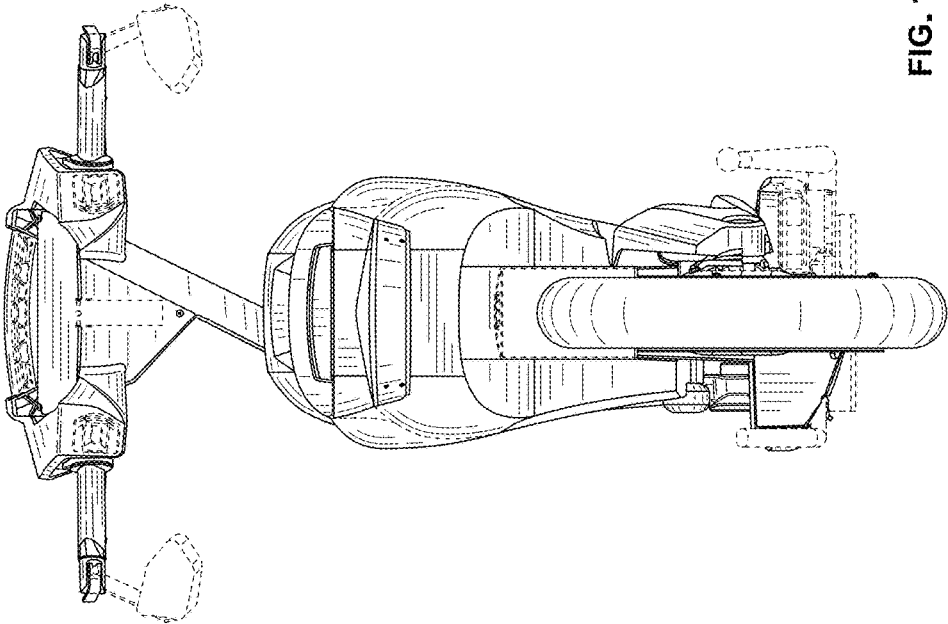

FIG. 10

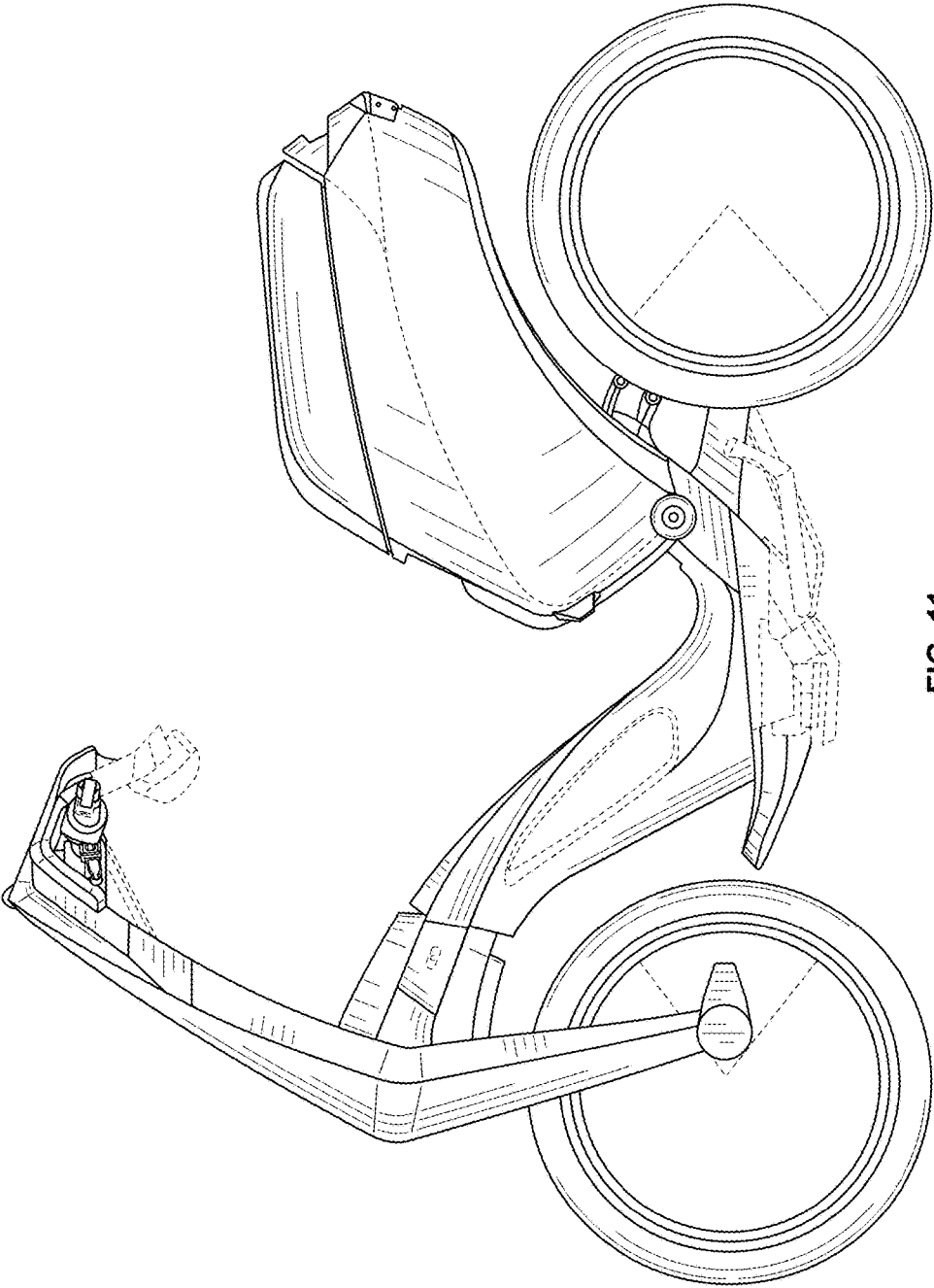

FIG. 11

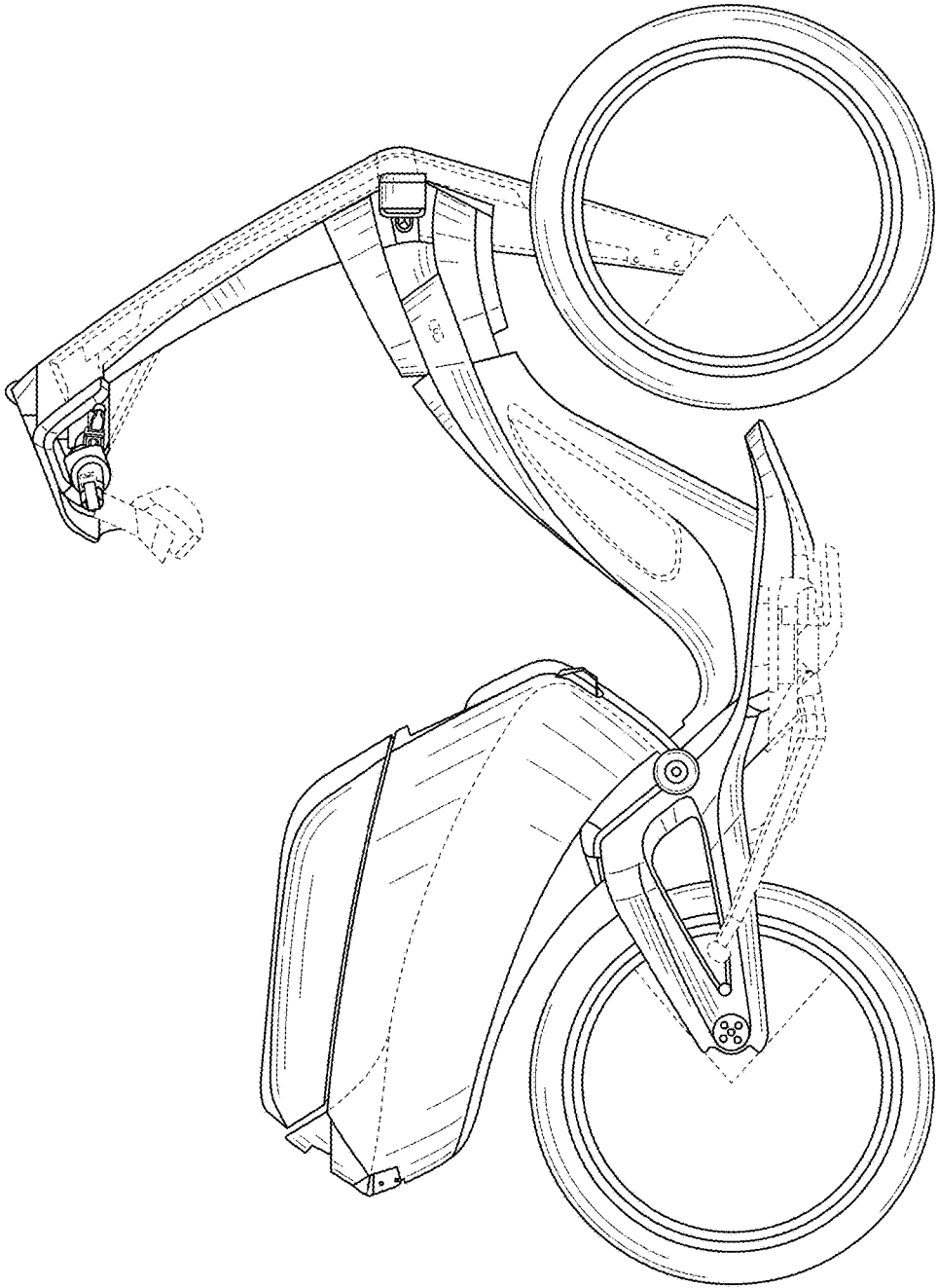

FIG. 12

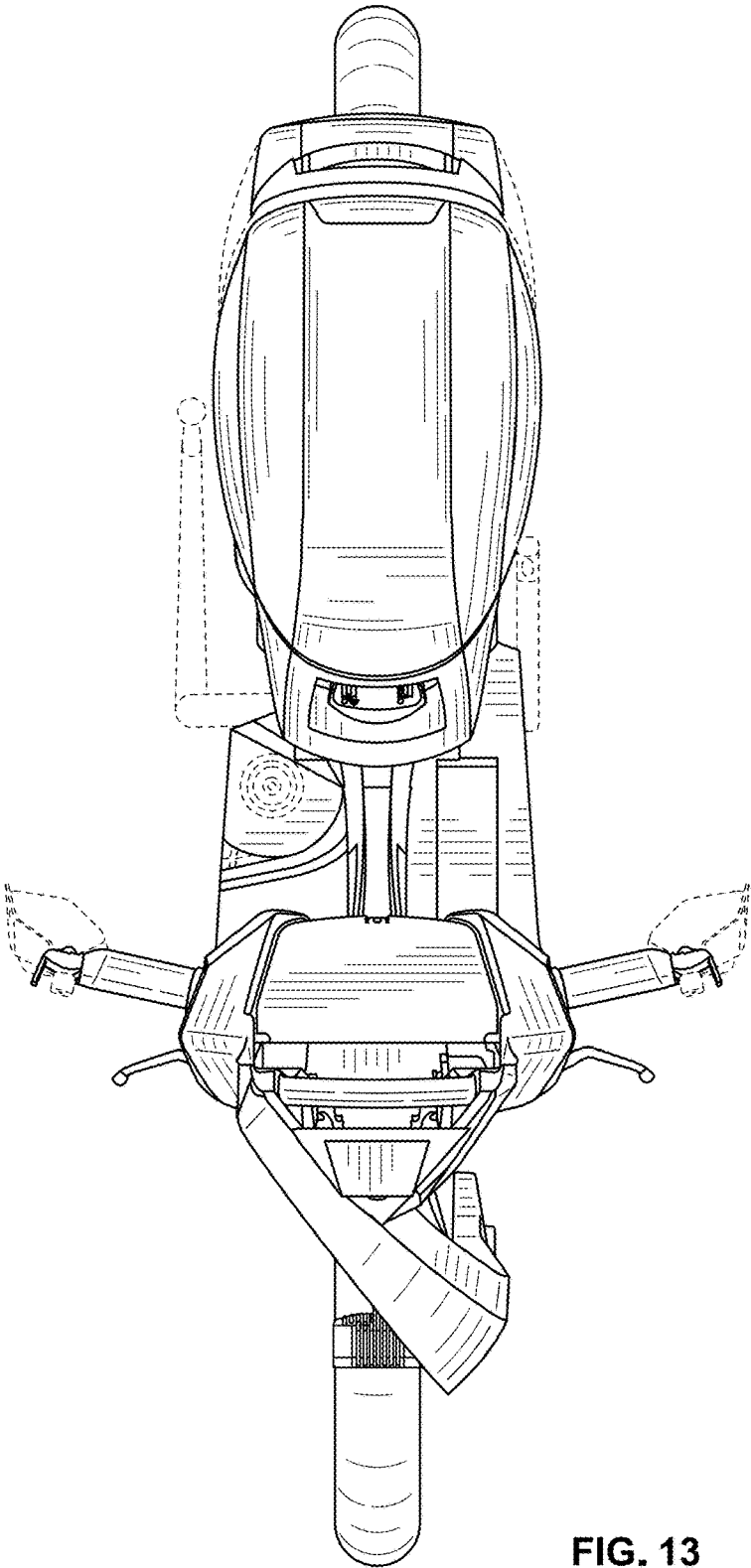

FIG. 13

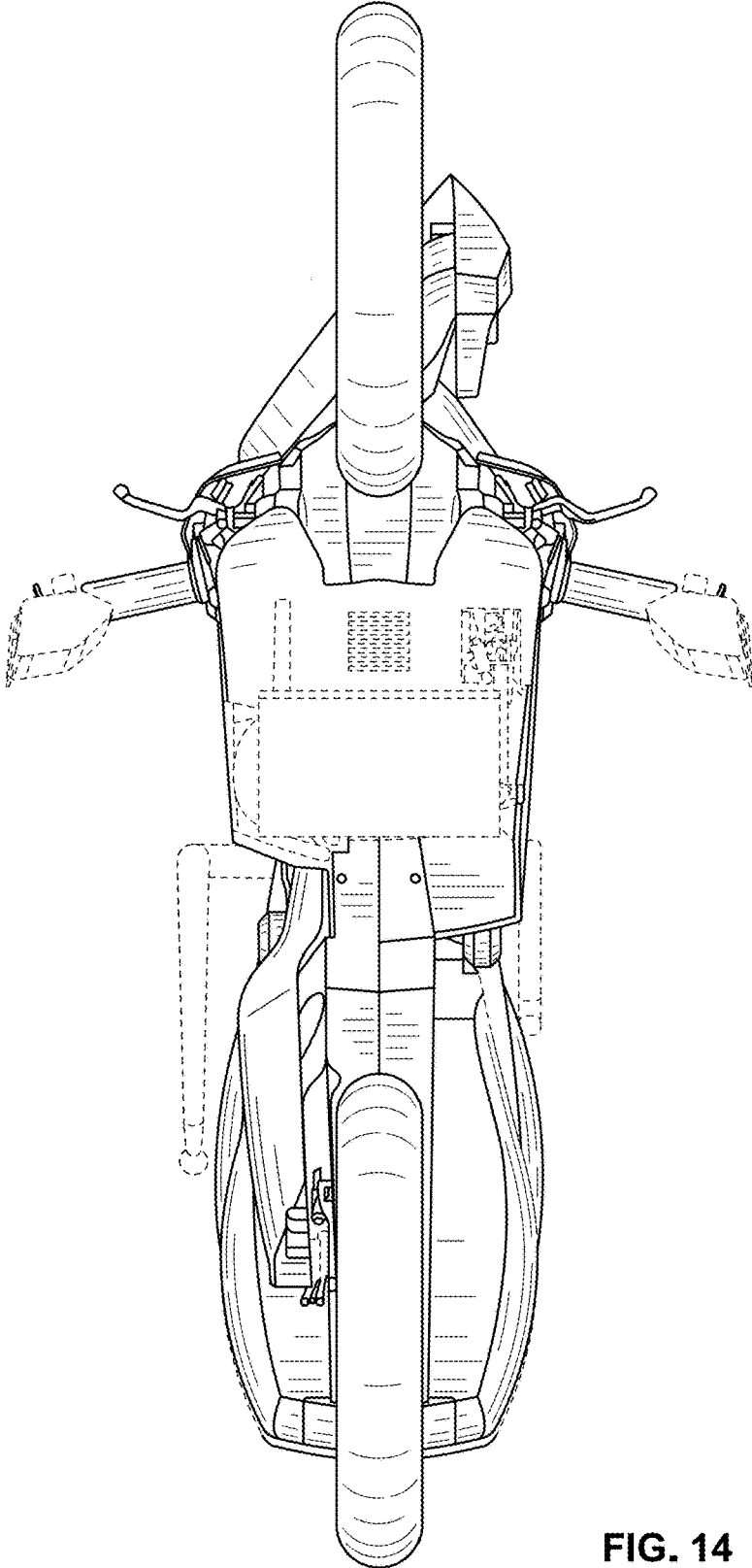

FIG. 14