

Oct. 7, 1969

J. A. AILEO

3,470,564

SAFETY HELMET WITH SOUND ATTENUATING EARCUPS

Filed Nov. 29, 1967

4 Sheets-Sheet 1

Fig. 1.

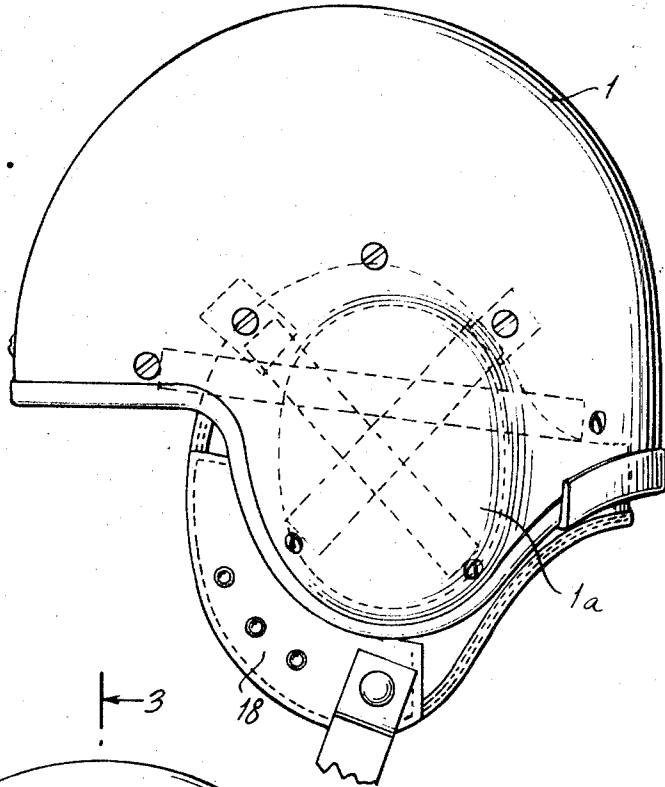
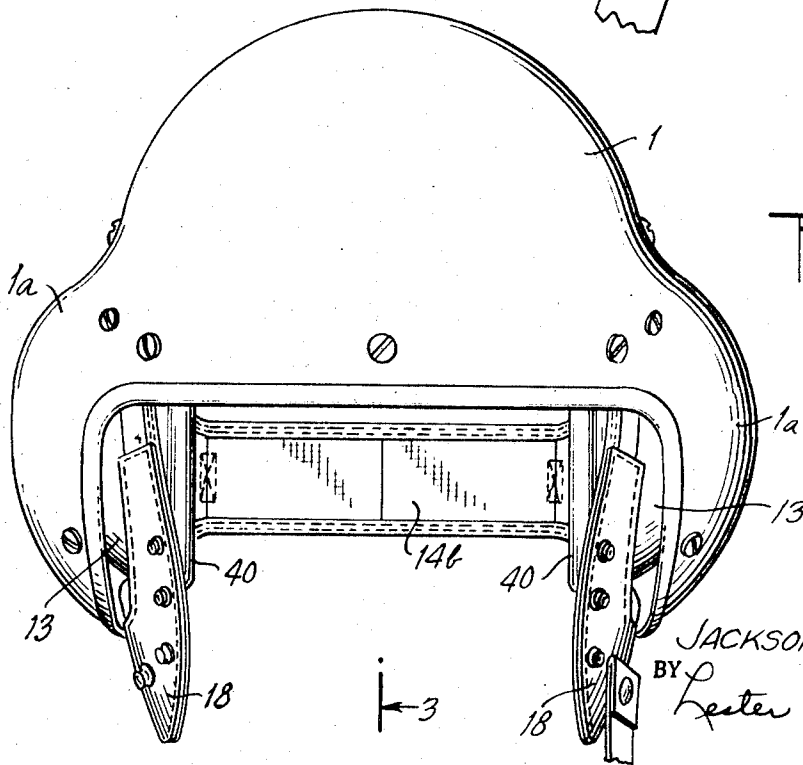

Fig. 2.



INVENTOR

JACKSON A. AILEO

BY

Lester H. Clark

ATTORNEY

Oct. 7, 1969

J. A. AILEO

3,470,564

SAFETY HELMET WITH SOUND ATTENUATING EARCUPS

Filed Nov. 29, 1967

4 Sheets-Sheet 2

Fig. 3.

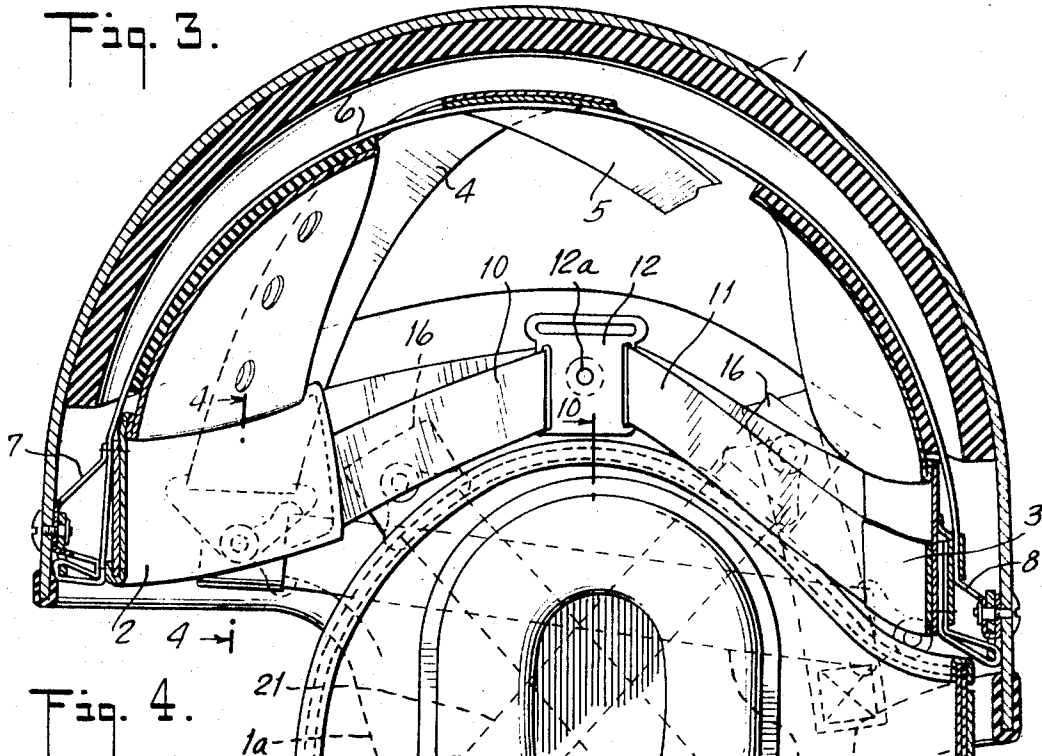

Fig. 4.

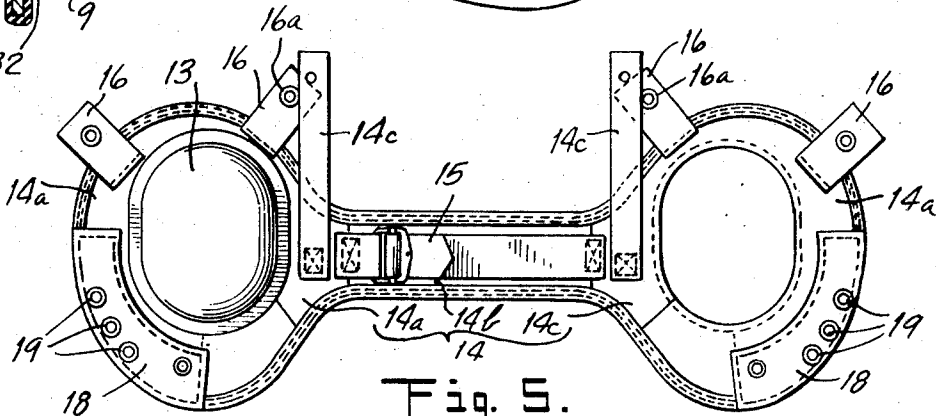
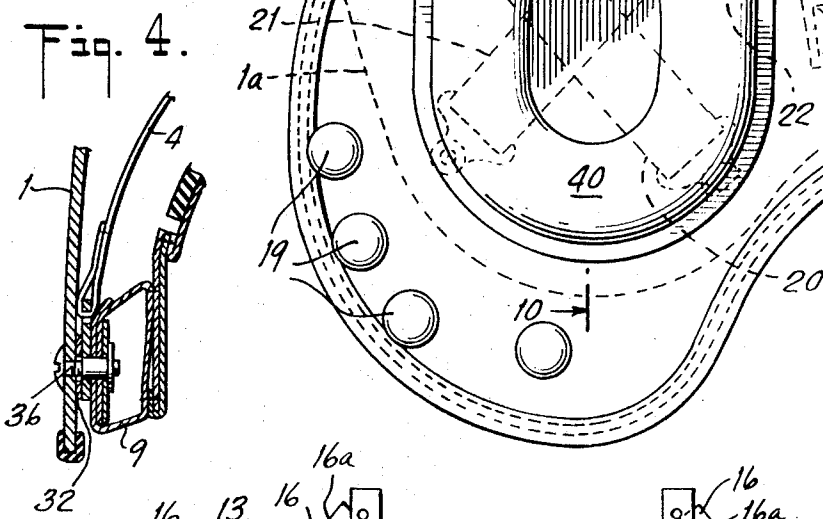

Fig. 5.

Oct. 7, 1969

J. A. AILEO

3,470,564

SAFETY HELMET WITH SOUND ATTENUATING EARCUPS

Filed Nov. 29, 1967

4 Sheets-Sheet 4

Fig. 10.

Fig. 11.

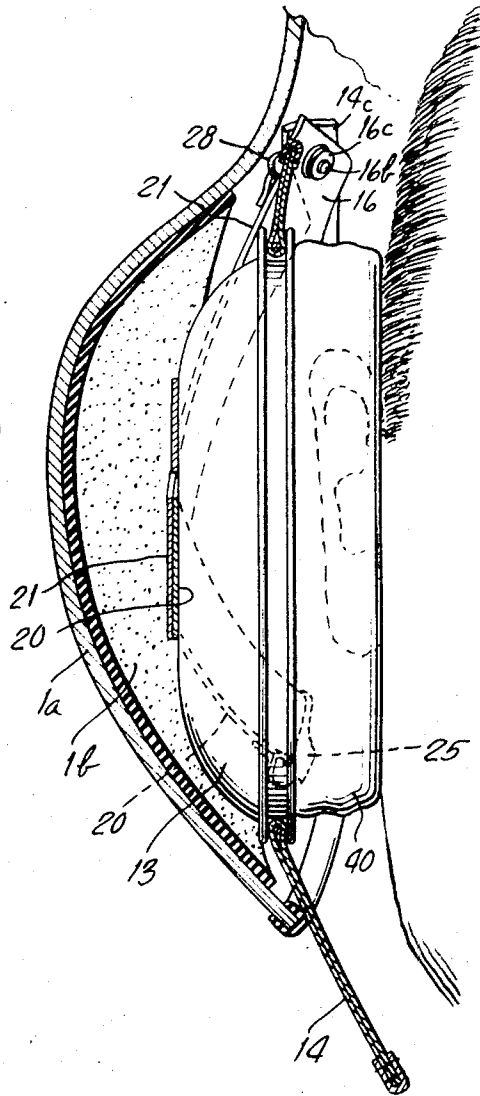
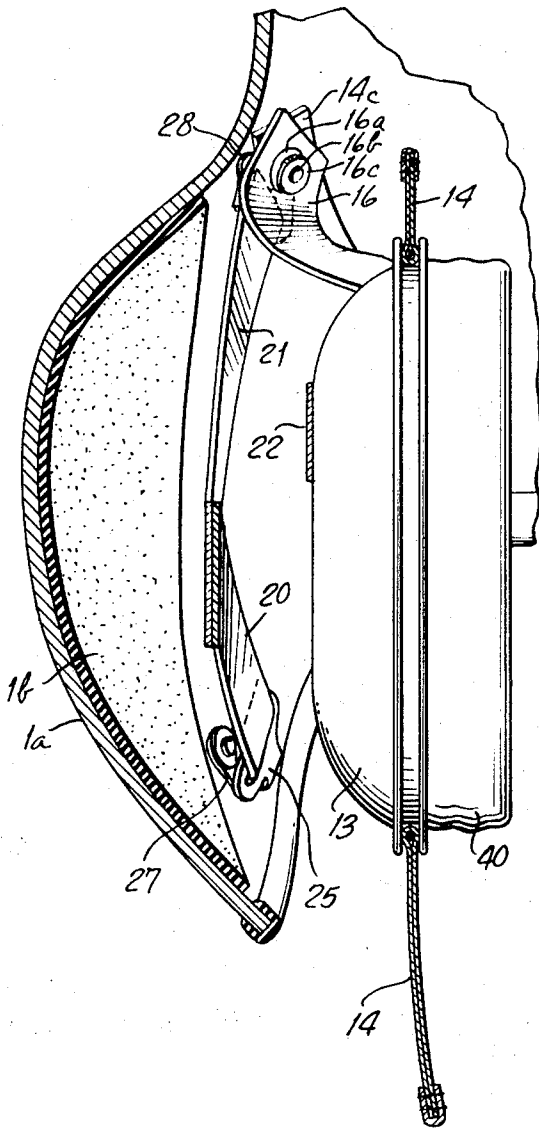

1

2

3,470,564

**SAFETY HELMET WITH SOUND
ATTENUATING EARCAPS**

Jackson A. Aileo, Carbondale, Pa., assignor, by mesne assignments, to Gentex Corporation, Carbondale, Pa., a corporation of Delaware

Filed Nov. 29, 1967, Ser. No. 686,500

Int. Cl. A42b 1/06, 1/08; A41d 21/00

U.S. Cl. 2—3

9 Claims

ABSTRACT OF THE DISCLOSURE

Safety helmet including a rigid shell, headband for supporting the shell on the head of a wearer, rigging connecting headband and shell, and downwardly projecting, inwardly concave ear covering portions on shell; sound attenuating earcups depending from shell by flexible connections, located inside the ear covering portions, yieldable pads extending around periphery of each cup, and adapted to engage the wearer's head, with areas of engagement encircling the wearer's ears; and apparatus for adjustably biasing each earcup against the wearer's head, including, for each earcup, at least one strap of elastic material, of adjustable length, attached at its ends to the helmet shell and spanning the inwardly concave ear covering portion of the shell. Second strap may extend at right angles to first. Modification includes third elastic adjustable strap, generally parallel to headband, and also spanning ear covering portion of shell. Releasable connection between at least one end of each strap and shell, so that biasing action of any strap may be substantially completely relieved.

Background of the invention

The invention relates to sound attenuating safety helmets, such as are worn by ground personnel when servicing jet aircraft, or by other personnel in high intensity sound areas. It is essential that such a safety helmet be equipped with sound attenuating means which is effective to protect the wearer's ears. Furthermore, the sound attenuating means should be adequately adjustable so that it will fit and effectively attenuate the sound of various people with various sizes and shapes of head.

A common form of sound attenuating means comprises an earcup of rigid material, usually molded plastic, adapted to enclose the wearer's ears, and provided on its periphery with a yieldable pad adapted to engage the wearer's head without causing discomfort. It is desirable to ensure a tight, sound attenuating engagement between the pad and the wearer's head, along a region extending entirely around the ear, without producing at any locality a heavy pressure which is uncomfortable to the wearer. The earcup is commonly constructed so that its periphery lies in a single plane, while the typical human head is contoured so that the region which must be engaged by the earcup periphery does not lie in a single plane. Hence, there must necessarily be some areas in that region where the yieldable pad exerts greater pressure than at other areas. The problem is to make sure that the pressure is high enough in all areas to attenuate sound waves, and that it is low enough in all areas so that the earcup may be worn comfortably.

The problem is made more difficult because it is desirable to manufacture the helmet and the sound attenuating means by mass production techniques, and yet have a structure which is adjustable to fit comfortably and effectively any of a wide variety of shapes and sizes of the human head.

My Patent No. 3,178,723 shows a safety helmet having a cover portion extending downwardly from the helmet shell over the ear of the wearer and a sound attenuating earcup between that portion of the shell and the wearer's head, and biased into engagement with the wearer's head by a spring. The spring of said patent is not adjustable either as to its tension or as to the angle at which the earcup engages the wearer's head.

My Patent No. 3,190,973 shows a safety helmet without downwardly depending ear covering portions, and earcups which are held by a cloth shield suspended from the helmet shell in alignment with the wearer's ears. No spring means is provided to bias the earcups into engagement with the ears. The force holding the earcups into engagement with the wearer's head about the ears is provided by a nape strap (267 in FIG. 8 or 35 in FIG. 1) and a cooperating chin strap (37 in FIG. 1). The nape strap and the chin strap are both adjustable. These two adjustments are effective to maintain the peripheral length of the encircling band including the shield; the nape strap and the chin strap, substantially equal to the length of the periphery of the wearer's head. Nevertheless, the human head typically has a number of humps and hollows in the area surrounding the ear, so that this peripheral adjustment may not be adequate, in the case of all wearers, to hold the earcup in engagement with the wearer's head throughout the periphery of the cup around the ear, so as to be comfortable, and also to effectively attenuate all high intensity sounds.

Summary of the invention

According to the present invention, there is provided a helmet shell having downwardly depending, inwardly concave side portions which extend over and cover the ear of the wearer. Between those ear covering portions of the shell and the wearer's head are located earcups, which are provided with resilient pads around their peripheries. These pads are the only parts of the earcup intended to touch the wearer's head. The earcups are suspended from the helmet shell by means of a cloth shield member supported at spaced points on the shell.

The important feature of my invention lies in the mechanism for adjustably biasing the earcup into engagement with the wearer's head. This mechanism includes one or more biasing straps of elastic material, stressed in tension and spanning the ear covering portion of the helmets, which are concave on their inward side. Each strap is adjustable as to length, and therefore as to its tension. One end of each strap is made readily detachable from the helmet, so that each strap may be rendered entirely ineffective in the event that the wearer's head is so shaped that that particular strap is not necessary. The most complete array disclosed herein includes three such biasing straps, two extending diagonally and crossing each other at right angles, and the third extending generally parallel to the headband which supports the helmet on the wearer's head. As to any particular wearer, only one or two of the three biasing straps may be necessary. The others may be detached and left dangling, as they do not interfere in any way with the utilization of the helmet when so detached.

Brief description of the drawings

FIG. 1 is a side elevational view of a helmet embodying the invention;

FIG. 2 is a front elevational view of the helmet of FIG. 1;

FIG. 3 is a sectional view taken along the line 3—3 of FIG. 2;

FIG. 4 is a sectional view taken along the line 4—4 of FIG. 3;

FIG. 5 is a developed elevational view of the supporting shield and the earcups supported thereon, removed from the helmet and spread out;

FIG. 6 is a view similar to FIG. 3, but with certain parts removed so as to illustrate more clearly the supporting structure for the several biasing straps;

FIG. 7 is a sectional view taken on the line 7—7 of FIG. 6;

FIG. 8 is a sectional view taken along the line 8—8 of FIG. 6;

FIG. 9 is a perspective view of a mounting bracket used for holding one end of a biasing strap;

FIG. 10 is a sectional view taken along the line 10—10 of FIG. 9, showing the parts in their positions when the helmet is not being worn; and

FIG. 11 is a sectional view similar to FIG. 10, but showing the parts in the positions which they take up when the helmet is mounted on a wearer's head.

Detailed description

A helmet shell 1, of a generally hemispherical contour has downwardly extending ear covering portions 1a, which are externally convex and inwardly concave. The inside surfaces of the portions 1a may be covered with a layer of sound absorbing material 1b.

Rigging means is provided for supporting the shell 1 on the head of a wearer. The rigging means includes headband comprising a front headband element 2, best seen in FIG. 3, and a rear headband element 3. The rigging means also includes three head straps 4, 5 and 6, which are adapted to extend over the wearer's head and are attached at their ends to the shell. A plurality of inelastic elements of fixed length connect the headband elements 2 and 3 to the shell. These inelastic elements include, middle loops 7 and 8 (FIG. 3), end loops 9 (only one of which is shown, see FIG. 4), and end straps 10 and 11 extending between the ends of the headband elements 2 and 3 and apertured anchor plates 12 attached to the shell by screws 12a. These connecting elements are made in elastic to prevent the wearer from adjusting the size of the headband in a manner so that the headband might come in contact with the shell, thereby allowing the direct transmission of an external blow through the shell to the wearer's head. Size adjustment of the headband means is accomplished by attaching a stack of one or more pads (not shown) of suitable thickness on the inner surface of the rear headband element 3, as described in greater detail in my copending application Ser. No. 614,246, filed Feb. 6, 1967.

Loops similar to the loop 9 of FIG. 4 are provided at each end of the front headband element 2 and at each of the rear headband element 3. Only the loop 9 at the right end of the front headband element 2 is illustrated, to avoid duplication.

The sound attenuating mechanism includes a pair of earcups 13 supported on a shield 14 by means described and claimed in my aforesaid Patent No. 3,190,973. The shield 14 includes two end portions 14a connected by a nape portion 14b. An adjustable strap 15 is connected at its end to the ends of the nape portion, so as to adjust the effective length of the nape portion and make it fit the wearer. The top of each of the spaced end portions 14a is provided with a pair of spaced tabs 16. The tabs 16 are provided with eyelets 16a to receive bolts 16b cooperating with nuts 16c to clamp the tabs 16 to attachment to the helmet shell 1. The shield 14 is also supported in part by a pair of vertically extending straps 14c, one on each end portion 14a near the nape portion 14b and apertured to receive the same bolts which support the tabs 16.

The end portions 14a of the shield are provided with heavy leather reinforcing sectors 18, on which are mounted snap connectors 19 for the ready attachment of a chin strap as disclosed in my aforesaid Patent No. 3,190,973.

The earcup biasing means is best illustrated in FIGS. 6

to 11. It includes two diagonal straps 20 and 21, and a generally horizontal strap 22.

The elastic strap 20 is connected at its upper end to an anchor plate 23 (FIG. 3) mounted on the shell and located near the front side of the downwardly extending ear covering portion 1a. A buckle 24 is located along the middle of the strap 20 so that its effective length, and hence its longitudinal tension, may be adjusted. At the lower right hand end of the strap 20, as it appears in FIG. 6, there is attached a hook 25, adapted to engage in aperture 26 formed in an angle bracket 27 mounted on the downwardly extending portion 1a of the shell. The bracket 27 is shown in detail in FIG. 9.

The biasing strap 21 similarly extends between an anchor plate 28, and a hook 29 adapted to engage an aperture in an angle bracket 30. A tension adjusting buckle 31 is provided between the end of the strap 21.

The strap 22 is similarly constructed, being attached at its front end to a loop formed in an anchor plate 32 and at its back end to a hook 33 adapted to engage an eye 34 formed in an anchor plate 35.

The anchor plates 23, 28 and 32 and the brackets 27 and 30 are attached to the shell by bolts and nuts of conventional construction. The anchor plate 32 is held in place by the same bolt 36 which holds the loop 9 in place, as seen in FIG. 4. The same bolt holds another anchor plate 37 that fastens one end of the headband 4 to the shell, and a flat plate 38 which holds the loop 9. A flanged nut 39 cooperates with bolt 36 to hold the assembly together. The plate 35 which engages the hook 33 is held by the same screw 37 which holds the corresponding loop at the right hand end of the back headband element 3 and also holds another anchor plate attaching one end of the head strap 5 to the shell. Thus, the elastic straps 22 are mounted on the shell 1 by the same mechanism which fastens the ends of the headband elements 2 and 3 to the shell, and no additional supporting structure is required.

In a similar fashion, the anchor plates 23 and 28 are held by the same screws 16b which hold the tabs 16 and the straps 14c fixed on the shell. The only additional supporting structure required for the elastic straps 20 and 21 are the anchor plates 27 and 30 and their associated bolts and nuts.

Operation

The operation of my invention may be best understood by reference to FIGS. 10 and 11. FIG. 10 illustrates the parts in the positions which they take up when the helmet is not in place on the head of a wearer. Under such conditions, the earcup 13 is supported on the shield 14 and is biased inwardly away from the shell by the horizontal strap 22. The earcup 13 will rest against whichever one of the three straps 20, 21, and 22 happens to be adjusted to the shortest length. The strap 22 was chosen in this instance simply for purposes of illustration. When the helmet is placed on the wearer's head, the earcup 13 is forced outwardly, until its outer surface engages all three of the straps 20, 21, and 22, as shown in FIG. 11.

It may be readily understood that the three straps may be adjusted as to length so as to control both the tension with which the earcup is compressed against the wearer's head and also to control the angle at which the earcup rests against the wearer's head. In this manner, the pressure against the wearer's head may be distributed evenly around the entire rim of the earcup and through the resilient pad structure 40 with which such earcups are conveniently supplied.

Each wearer may adjust the tensions of the straps 20, 21 and 22 to suit the contour of his own head. If he doesn't need one of the straps, he may quickly render it ineffective by disengaging the hook provided at one end.

I claim:

1. Sound attenuating helmet apparatus, including:

(a) a rigid shell adapted to receive the head of a wearer, said shell having at least one downwardly

5

extending, inwardly concave side portion adapted to extend over one of the wearer's ears when the helmet is in place on his head;

- (b) rigging means for supporting the helmet on the wearer's head, including headband means encircling the wearer's head above the ears, 5
- (c) earcup means depending from said shell including a rigid cup located in lateral alignment with said concave side portion and adapted to enclose said one of the wearer's ears, and resilient seal means extending around the rim of the cup and adapted to engage the wearer's head along a locality encircling said one ear; 10

wherein the improvement comprises:

- (d) means for adjustably biasing the ear cup to hold the resilient seal means tightly against the wearer's head about the entire periphery of the cup, said biasing means including: 15
- (e) a stretchable strap stressed longitudinally in tension and spanning said downwardly extending, inwardly concave ear cover inside the helmet shell, said strap being attached at its ends to the shell and adapted to engage resiliently the outer side of the ear cup when the helmet is in place on the wearer's head. 25

2. Sound attenuating helmet apparatus as defined in claim 1, including means for adjusting the longitudinal tension in said strap.

3. Sound attenuating apparatus as defined in claim 1, including means for disengaging one end of the strap from the helmet shell. 30

4. Sound attenuating helmet apparatus as defined in claim 3, in which said disengaging means comprises a hook on the end of the strap and an apertured anchor plate attached to the shell. 35

5. Sound attenuating helmet apparatus as defined in claim 1, including two stretchable straps spanning said ear cover inside the shell and crossing one another substantially at right angles.

6. Sound attenuating helmet apparatus as defined in claim 5, in which said two straps extend diagonally across said ear cover. 40 2—209

6

7. Sound attenuating helmet apparatus as defined in claim 5, including a third strap spanning said ear cover inside the shell, and extending parallel to said headband means and adapted to engage the earcup near the top thereof.

8. Sound attenuating helmet apparatus as defined in claim 1, in which said earcup means includes:

- (a) a shield of flexible material adapted to extend from one side of the wearer's head around the nape of his neck to the other side of his head, said shield encircling earcups at both sides of the helmet;
- (b) means supporting said shield from the headband means including two spaced tabs extending upwardly at the top of the shield adjacent each earcup; and
- (c) a pair of connecting means attaching the upper end of said tabs to the helmet shell, one of said pair of connecting means also attaching one end of said strap to the shell.

9. Sound attenuating helmet apparatus as defined in claim 1, including:

- (a) spaced headband attaching means on said shell located forward and rearward of said concave side portion; and
- (b) means including said spaced headband attaching means for fixing the ends of said stretchable strap to the shell.

References Cited

UNITED STATES PATENTS

2,805,419	9/1957	Finken	2—3
3,005,203	10/1961	Aileo	2—3
3,021,526	2/1962	Lastnik	2—3
3,400,406	9/1968	Aileo	2—6

MERVIN STEIN, Primary Examiner

GEORGE H. KRIZMANICH, Assistant Examiner

U. S. Cl. X.R.