

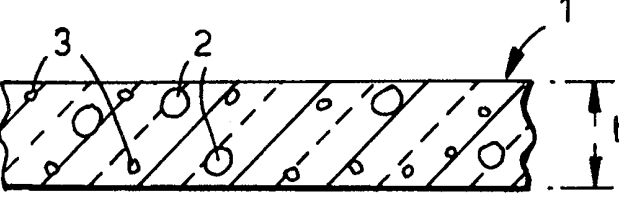

## INTERNATIONAL APPLICATION PUBLISHED UNDER THE PATENT COOPERATION TREATY (PCT)

(51) International Patent Classification <sup>7</sup> : <b>C08J 7/04, C09D 183/04, G02B 1/10</b>	<b>A1</b>	(11) International Publication Number: <b>WO 00/06633</b>  (43) International Publication Date: 10 February 2000 (10.02.00)
<p>(21) International Application Number: PCT/GB99/02414</p> <p>(22) International Filing Date: 26 July 1999 (26.07.99)</p> <p>(30) Priority Data: 9816269.6                      27 July 1998 (27.07.98)                      GB</p> <p>(71) Applicant (for all designated States except US): PILKINGTON PLC [GB/GB]; Prescott Road, St. Helens, Merseyside WA10 3TT (GB).</p> <p>(72) Inventor; and (75) Inventor/Applicant (for US only): HOLMES, Paul, Arthur [GB/GB]; Bankcroft Cottage, Cliff Road, Acton Bridge, Northwich, Cheshire CW8 3QY (GB).</p> <p>(74) Agents: HALLIWELL, Anthony, Charles et al.; Pilkington plc, Group Intellectual Property Dept., Pilkington Technology Centre, Hall Lane, Lathom, Ormskirk, Lancashire L40 5UF (GB).</p>	<p>(81) Designated States: AE, AL, AM, AT, AU, AZ, BA, BB, BG, BR, BY, CA, CH, CN, CU, CZ, DE, DK, EE, ES, FI, GB, GD, GE, GH, GM, HR, HU, ID, IL, IN, IS, JP, KE, KG, KP, KR, KZ, LC, LK, LR, LS, LT, LU, LV, MD, MG, MK, MN, MW, MX, NO, NZ, PL, PT, RO, RU, SD, SE, SG, SI, SK, SL, TJ, TM, TR, TT, UA, UG, US, UZ, VN, YU, ZA, ZW, ARIPO patent (GH, GM, KE, LS, MW, SD, SL, SZ, UG, ZW), Eurasian patent (AM, AZ, BY, KG, KZ, MD, RU, TJ, TM), European patent (AT, BE, CH, CY, DE, DK, ES, FI, FR, GB, GR, IE, IT, LU, MC, NL, PT, SE), OAPI patent (BF, BJ, CF, CG, CI, CM, GA, GN, GW, ML, MR, NE, SN, TD, TG).</p> <p><b>Published</b> <i>With international search report.</i></p>	
(54) Title: COATING FOR PLASTIC SUBSTRATE		
(57) Abstract		
<p>A coating (1, 30) resistant to scratching for a plastic substrate (20), comprises a number of components including an inorganic polymer (2) and an inorganic filler (3) wherein at least all but one of the components have a particle size towards the lower range of or below the wavelength of visible light. Such a coating (1, 30) has a single effective refractive index and problems associated with matching the refractive indexes of the individual components of the coating (1, 30) are avoided. The coating (1, 30) is particularly advantageous in applications where it is subject to temperature changes, for example on automotive glazings which are subject to climatic changes in temperature. The surface durability of the coating (1, 30) may be enhanced by exposing at least part of its surface to a plasma treatment process.</p>		

**FOR THE PURPOSES OF INFORMATION ONLY**

Codes used to identify States party to the PCT on the front pages of pamphlets publishing international applications under the PCT.

AL	Albania	ES	Spain	LS	Lesotho	SI	Slovenia
AM	Armenia	FI	Finland	LT	Lithuania	SK	Slovakia
AT	Austria	FR	France	LU	Luxembourg	SN	Senegal
AU	Australia	GA	Gabon	LV	Latvia	SZ	Swaziland
AZ	Azerbaijan	GB	United Kingdom	MC	Monaco	TD	Chad
BA	Bosnia and Herzegovina	GE	Georgia	MD	Republic of Moldova	TG	Togo
BB	Barbados	GH	Ghana	MG	Madagascar	TJ	Tajikistan
BE	Belgium	GN	Guinea	MK	The former Yugoslav Republic of Macedonia	TM	Turkmenistan
BF	Burkina Faso	GR	Greece			TR	Turkey
BG	Bulgaria	HU	Hungary	ML	Mali	TT	Trinidad and Tobago
BJ	Benin	IE	Ireland	MN	Mongolia	UA	Ukraine
BR	Brazil	IL	Israel	MR	Mauritania	UG	Uganda
BY	Belarus	IS	Iceland	MW	Malawi	US	United States of America
CA	Canada	IT	Italy	MX	Mexico	UZ	Uzbekistan
CF	Central African Republic	JP	Japan	NE	Niger	VN	Viet Nam
CG	Congo	KE	Kenya	NL	Netherlands	YU	Yugoslavia
CH	Switzerland	KG	Kyrgyzstan	NO	Norway	ZW	Zimbabwe
CI	Côte d'Ivoire	KP	Democratic People's Republic of Korea	NZ	New Zealand		
CM	Cameroon			PL	Poland		
CN	China	KR	Republic of Korea	PT	Portugal		
CU	Cuba	KZ	Kazakistan	RO	Romania		
CZ	Czech Republic	LC	Saint Lucia	RU	Russian Federation		
DE	Germany	LI	Liechtenstein	SD	Sudan		
DK	Denmark	LK	Sri Lanka	SE	Sweden		
EE	Estonia	LR	Liberia	SG	Singapore		

## Coating for Plastic Substrate

### Technical Field

This invention relates to a coating resistant to scratching and in particular to plastic glazings for automotive use which incorporate such a coating.

### Background Art

Glazings for automotive use conventionally comprise safety glass which may be laminated (widely used for windscreens) or toughened (widely used for sidelights and backlights). The desire to improve vehicle fuel consumption makes it desirable to provide an automotive glazing lighter in weight than a conventional automotive glazing, whilst maintaining the structural rigidity and toughness required in automotive glazings.

Plastic glazings for vehicles have been tried with limited success. Such glazings generally comprise a synthetic resin, such as polycarbonate or acrylic, which has a lower density than glass. However these synthetic resins have poor resistance to scratching, that is abrasion resistance (resistance to marking by an abrasive pad) and/or scratch resistance (resistance to a permanent visible scratch from a point load), and their surface durability may be improved by application of a coating resistant to scratching. Conventional thin (1 to 10  $\mu\text{m}$ ) hard coats such as siloxane have been applied to the surface of plastic glazings by dip coating, but their application is costly and time consuming.

GB 2305890 discloses an alternative method of providing a coating resistant to scratching on a plastic substrate. A mixture of a resin and a glass filler form a hard coating on the substrate surface which is resistant to scratching. In applications where the transmission of visible light through the substrate is required, such as automotive glazings, this coating may cause problems. It is important that the refractive index of both the resin and the glass filler correspond because a mismatch between them leads to haze in the glazing. Matching the refractive indexes of these materials is difficult

and even if matched, the temperature dependence of refractive index is unlikely to be the same for both materials, and so haze develops in the glazing as the temperature changes. This problem is particularly prevalent in outdoor glazings which are subject to climatic changes in temperature.

We have found that selection of the components of a coating resistant to scratching with appropriate particle size (ie diameter), eliminates the need to match the refractive indexes of those components.

### Disclosure of the Invention

According to a first aspect of the invention there is provided a coating resistant to scratching for a plastic substrate, the coating comprising a plurality of components including an inorganic polymer and an inorganic filler wherein at most only one of the components has a particle size towards the lower range of or above the wavelength of visible light. The coating has a single effective refractive index and the aforementioned problems associated with matching the refractive indexes of the individual components are avoided. Such a coating is particularly advantageous in applications where the coating is subject to temperature changes, for example on automotive glazings which are subject to climatic changes in temperature.

Other components that may be incorporated into the coating include hydrophobic additives, hydrophilic additives, anti-static additives and/or photocatalytic additives. In each case the additive should have a particle size below or towards the lower range of the wavelength of visible light.

The inorganic polymer may be thermoplastic which enables the coating to be applied to a plastic substrate by a number of methods, such as laminating a preformed film of the coating to the substrate, co-extruding a film of the coating with the plastic substrate, or by a multiple injection moulding method.

The coating may have a thickness of at least 0.05mm and preferably has a thickness of at least 0.1mm.

The inorganic polymer is preferably a silicone resin and the inorganic filler is preferably colloidal silica having a particle size less than about 500 nm.

The coating may be exposed to a plasma treatment process to decompose the inorganic polymer to its organic oxide. The plasma treatment modifies the surface of the coating in such a way to enhance its resistance to scratching. Particularly in the case where the inorganic polymer comprises a silicone resin, the silicone resin decomposes to silica which is well known to have excellent resistance to scratching.

The inorganic oxide of the plasma treated surface may have a thickness of at least 5 nm providing an extremely thin surface which is particularly resistant to scratching.

The coating may also include an ultra-violet absorbing or reflecting species.

According to a second aspect of the invention there is provided a plastic glazing comprising a plastic substrate having a coating according to the first aspect of the invention applied to at least one of its surfaces.

An adhesive having a low modulus (one having a tensile modulus of less than about 100MPa, preferably less than 10MPa) may be employed to improve the adhesion between the coating and the substrate. The low modulus layer is also believed to enhance the energy absorption and impact resistance of the glazing by at least reducing or preventing cracks propagating from the coating through to the substrate by blunting the crack tip.

The coating may surround the plastic substrate so that each surface of the glazing is resistant to scratching.

The plastic substrate is preferably impact resistant and polycarbonate is a particularly suitable material.

Plastic glazings according to the invention may be at least 3mm thick and in certain applications it may be desirable for them to have a greater thickness. For example they may be installed into the openings of vehicles in which the width of the glazing channels is nominally 4mm or 5mm or more.

Use of the structure of the present invention permits the production of durable plastic glazings, including curved glazings, which are suitable for automotive use

The glazing may further include at least one ultra-violet (uv) absorbing or reflecting layer which when the glazing is fitted into a vehicle, may serve to protect the interior of the vehicle from degradation by sunlight. In addition the uv absorbing or reflecting species may serve to protect an aromatic plastic substrate (one that includes aromatic units in the polymer chains), such as polycarbonate, which tends to degrade on exposure to uv radiation.

According to a third aspect of the invention there is provided a method of forming a plastic glazing by multiple injection moulding comprising the steps of injecting a skin material into a mould, the skin material comprising a plurality of components including an inorganic polymer and an inorganic filler and at most only one of the components has a particle size towards the lower range of or above the wavelength of visible light, injecting a plastic substrate material into the mould which forces the skin material to the surfaces of the mould such that in the finished glazing the skin material forms a coating which surrounds the plastic substrate. As the glazing is injection moulded it may be manufactured in a variety of shapes with a surface finish dictated by the surface of the mould cavity without the need for a clean environment. In particular curved glazings suitable for automotive use may be manufactured.

A low modulus material may be injected into the mould after the injection of the skin material and before injection of the plastic substrate material so that in the finished glazing the low modulus material is located between the coating and the plastic substrate. The low modulus layer may improve the adhesion between the skin and the substrate and may enhance the energy absorption and impact resistance of the glazing by at least reducing or preventing cracks propagating from the coating through to the substrate by blunting the crack tip.

The skin material may comprise a silicone resin and the inorganic filler may comprise colloidal silica having a particle size less than about 500nm.

The method preferably comprises the further step of exposing at least one surface of the glazing to a plasma treatment process which causes the inorganic polymer to decompose to its inorganic oxide. In the case when the skin material comprises a silicone resin, the plasma treatment decomposes the silicone to silica which has a good finish and is well known to have excellent resistance to scratching.

#### Brief Description of the Drawings

Figure 1 and 2 are enlarged schematic cross sections of a coating according to the invention.

Figures 3 and 4 are schematic cross sections of a dual injection moulding system for moulding a glazing according to an embodiment of the invention.

Figure 5 is a schematic cross section of an injection moulded glazing according to an embodiment of the invention.

Figure 6 is a schematic cross section of a the glazing of Figure 5 which has been exposed to a plasma treatment process.

Figure 7 is a schematic cross section of an injection moulded glazing according to another embodiment of the invention which has been exposed to a plasma treatment process.

#### Description

A coating resistant to scratching which is suitable for use on a plastic glazing, in particular an automotive glazing, is shown in Figure 1. For simplicity, only specimen particles of the components of the coating are shown in Figures 1 and 2. The coating 1 may have a thickness  $t$  of at least 0.05mm but preferably is at least 0.1mm thick. The coating comprises a random mixture of an inorganic polymer 2 such as a silicone resin, for example polydimethylsiloxane, and an inorganic filler 3 such as colloidal silica. The inorganic filler has a particle size towards the lower range of or below the wavelength of visible light (400 - 700nm) and typically colloidal silica has a particle size of less than about 500nm and commonly less than about 100nm. The

polydimethylsiloxane may comprise between about 20% to 80 % by weight of the coating with the remainder comprising colloidal silica. Preferably the proportion is about 50% of each. Such a coating has a single effective refractive index and problems concerned with matching the refractive indexes of the individual components are avoided. This is particularly advantageous in situations where the coating is subject to temperature changes, for example on automotive glazings which are subject to climatic changes in temperature. If more than one of the components of the coating has a particle size above the lower range of visible light then the refractive indexes of those components would need to be matched or haze would develop in the glazing. Even if their refractive indexes were matched it is likely that haze would develop as the temperature changes because the temperature dependence of refractive index is unlikely to be the same for each component.

It will be appreciated that relatively small quantities of other components may be incorporated into the coating to provide the coating with additional properties. For example pigments and/or dyes may be incorporated to provide a tint or solar control properties, especially uv protection, to the coating (and hence a glazing when applied thereto). When the coating is applied to a plastic glazing which is fitted into a vehicle, the uv absorbing or reflecting species may serve to protect the interior of the vehicle from degradation by sunlight. In addition, the uv absorbing or reflecting species may serve to protect an aromatic plastic substrate (one that includes aromatic units in the polymer chains), such as polycarbonate, which tends to degrade on exposure to uv radiation. Hydrophobic additives (such as a fluorinated compound to impart anti-soiling and rain shedding properties), hydrophilic additives (such as a surfactant for anti misting properties), anti-static additives and/ or photocatalytic additives (such as titanium dioxide in anatase form for self cleaning properties) are examples of further components which may be incorporated into the coating. In each case the additive should have a particle size towards the lower range of or below the wavelength of visible light to avoid the aforementioned problems concerned with matching the refractive indexes of the individual components of the coating.



The surface durability of the coating may be enhanced by exposing a surface of the coating to a plasma treatment process to modify its surface, and a coating which has been so treated is shown in Figure 2. A suitable plasma system known to those skilled in the art is used in which the outer surface of the inorganic polymer decomposes to its inorganic oxide. The plasma gas is an oxidising gas such as air or oxygen. The coating is exposed to the plasma treatment for a time sufficient to allow an oxide layer 5 having a thickness of at least 5nm to be formed at the surface, but it will be appreciated that thicker layers, for example up to 100nm, may be desirable in certain applications to improve further the surface hardness and resistance to scratching. In the case where the inorganic polymer 2 comprises polydimethylsiloxane and the inorganic filler 3 comprises colloidal silica having a particle size less than about 500 nm, the plasma treatment process causes the polydimethylsiloxane to decompose to silica which has a good finish and is well known to be particularly resistant to scratching, and the coating is suitable for use in automotive glazings which require this property.

The inorganic polymer component of the coating may be a thermoset material but is preferably a thermoplastic material which enables the coating to be applied to a suitable plastic substrate, such as polycarbonate or acrylic, by a number of methods. The coating may be formed as a film by conventional methods such as extrusion or blow moulding, and the film may be adhered to the substrate by heating under pressure. Adhesion may be improved by bonding the coating to the substrate with a suitable low modulus adhesive layer, for example a preformed interlayer having a tensile modulus of less than about 100MPa and preferably less than 10MPa. Polyurethane or PVB are suitable adhesive layers, and a thickness of as little as 10 microns and ideally about 100 microns can be used for this purpose, although the ready availability of these materials in greater thickness, eg 0.38mm, may make it more convenient to use somewhat thicker layers than is necessary.

The use of a low modulus adhesive layer improves the adhesion between the coating and the substrate and has the added advantage of enhancing the energy

absorption and impact resistance of the glazing. It is believed that the low modulus adhesive at least reduces or prevents cracks propagating from the coating through to the substrate by blunting the crack tip.

In an alternative method the coating and plastic substrate (and adhesive layer if desired) may be coextruded and then cut to shape to form a glazing.

A coated plastic glazing may also be formed by a multiple injection moulding method which is used to form multi layered products. Referring to Figures 3 to 7, a mould 10 comprises mould sections 12 and 14 defining a mould cavity 16, and is mounted on a multiple injection moulding machine of known type. Such machines are available in commerce from Battenfeld Fischer of Lohmar, Germany. A skin material 18 comprising a mixture of an inorganic polymer such as a silicone resin, for example polydimethylsiloxane, and an inorganic filler such as colloidal silica having a particle size of less than about 500 nm, is firstly injected into cavity 16 slightly ahead of a core material 20 such as polycarbonate. Injection of the core material 20 forces the skin material to the periphery of the cavity to the extent that on completion of the injecting, the skin material 18 surrounds the core material 20 in the form of a coating 30. The moulded composite 31 is cured prior to removal from the mould.

The amount of skin material is chosen such that in the finished glazing its thickness is at least 0.05mm and preferably at least 0.1 mm. The polydimethylsiloxane may comprise between about 20% to 80 % by weight of the skin material with the remainder comprising colloidal silica. Preferably the proportion is about 50% of each.

It will be appreciated that other components may be incorporated into the skin material to provide the coating with additional properties. For example pigments and or dyes may be incorporated to provide a tint or solar control properties, especially uv protection, to the coating (and hence the glazing). Other components that may be incorporated include hydrophobic additives, hydrophilic additives, anti-static additives and/or photocatalytic additives. As previously described with reference to

the coating as such, in each case the additive should have a particle size towards the lower range of or below the wavelength of visible light.

The surface durability of the glazing may be enhanced by exposing at least one of its major surfaces to a plasma treatment process as hereinbefore described to modify the surface of the coating. Figure 6 (not to scale) shows such a glazing which has had all of its surfaces exposed to a plasma treatment and comprises an outer silica layer 32, a layer 30 comprising a mixture of polydimethylsiloxane and colloidal silica and a layer 20 of polycarbonate. It will be appreciated that if desired only one surface of the glazing may be exposed to plasma treatment, for example by masking all but one surface prior to the plasma treatment, so that only one surface of the glazing has a silica surface. Such a glazing is particularly suitable as an automotive glazing with the silica surface outermost thereby avoiding dangerous spall within the vehicle when impact of the glazing occurs.

The glazing may also include a low modulus adhesive layer 34 having a tensile modulus of less than about 100MPa and preferably less than 10MPa between the core and the skin by injecting the low modulus material after injection of the skin material and before injection of the core material. Polyurethane or PVB are examples of suitable low modulus materials and an amount of such material is selected so that in the finished glazing its thickness is as little as 10 microns, although ideally a thickness of 100 microns or more may be used.

As the glazing is formed by moulding it may be manufactured in a variety of shapes with a surface finish dictated by the surface of the mould cavity without the need for a clean environment. In particular curved glazings suitable for automotive use may be manufactured.

Glazings in accordance with the present invention may be manufactured at thicknesses suitable to be fitted into openings, especially motor vehicle openings, designed to be glazed with conventional nominal 3mm glazings. However some automotive glazings are designed to be glazed with glazings nominally 4mm or 5mm or more and so the glazing may be up to 5mm or more.

It will be appreciated that solar control materials, such as uv absorbing or reflecting species, may be loaded into a component of the glazing other than the coating to provide the glazing with desirable solar control properties. The glazing may include a specific uv absorbing or reflecting layer but preferably the uv absorbing or reflecting species is loaded into at least one of the components of the glazing, in particular the low modulus layer. An infra red absorbing or reflecting species may likewise be incorporated into a component of the glazing.

Claims

1. A coating (1, 30) resistant to scratching for a plastic substrate (20), the coating (1, 30) comprising a plurality of components including an inorganic polymer (2) and an inorganic filler (3) wherein at most only one of the components has a particle size towards the lower range of or above the wavelength of visible light.
2. A coating (1, 30) as claimed in claim 1 wherein the inorganic polymer (2) is thermoplastic.
3. A coating (1, 30) as claimed in claim 1 or claim 2 having a thickness of at least 0.05 mm.
4. A coating (1, 30) as claimed in any preceding claim wherein the inorganic filler (3) comprises colloidal silica having a particle size less than about 500 nm.
5. A coating (1, 30) as claimed in any preceding claim wherein the inorganic polymer (2) comprises a silicone resin.
6. A coating (1, 30) as claimed in any preceding claim wherein at least part of the surface of the coating is exposed to a plasma treatment process causing the inorganic polymer (2) to decompose to its inorganic oxide.
7. A coating (1, 30) as claimed in claim 6 when dependent on claim 5 wherein the inorganic oxide is silica.
8. A coating (1, 30) as claimed in claim 6 or claim 7 wherein the inorganic oxide has a thickness of at least 5 nm.

9. A coating (1, 30) as claimed in any preceding claim including an ultra-violet absorbing or reflecting species.
10. A plastic glazing (31) comprising a plastic substrate (20) having a coating (1, 30) as claimed in any of claims 1 to claim 9 applied to at least one of its surfaces.
11. A plastic glazing (31) as claimed in claim 10 wherein a low modulus adhesive (34) bonds the coating to the substrate.
12. A plastic glazing (31) as claimed in claim 10 or claim 11 wherein the coating (1, 30) surrounds the plastic substrate (20).
13. A plastic glazing (31) as claimed in any of claims 10 to 12 wherein the plastic substrate (20) is impact resistant.
14. A plastic glazing (31) as claimed in claim 13 wherein the plastic substrate (20) is polycarbonate.
15. A plastic glazing (31) as claimed in any of claims 10 to 14 wherein the glazing has a thickness of at least 3 mm.
16. A curved plastic glazing (31) as claimed in any of claims 10 to 16.
17. An automotive plastic glazing (31) as claimed in any of claims 10 to 17.
18. An automotive plastic glazing (31) as claimed in claim 18 having solar control properties.

19. A plastic glazing (31) as claimed in any of claims 9 to 18 wherein the glazing includes at least one ultra-violet absorbing or reflecting layer.
20. A method of forming a plastic glazing (31) by multiple injection moulding comprising the steps of injecting a skin material (18) into a mould (10), the skin material comprising a plurality of components including an inorganic polymer (2) and an inorganic filler (3) and at most only one of the components has a particle size towards the lower range of or above the wavelength of visible light, injecting a plastic substrate material (20) into the mould (10) which forces the skin material (18) to the surfaces of the mould (10) such that in the finished glazing (31) the skin material forms a coating (30) which surrounds the plastic substrate(20).
21. A method as claimed in claim 20 wherein a low modulus material (34) is injected into the mould (10) after injection of the skin material (18) and before injection of the plastic substrate material (20) so that in the finished glazing (31) the low modulus material (34) is located between the coating (30) and the plastic substrate (20).
22. A method as claimed in claim 20 or claim 21 wherein the inorganic filler (3) comprises colloidal silica having a particle size less than about 500 nm.
23. A method as claimed in claim 22 wherein the inorganic polymer (2) comprises a silicone resin.
24. A method as claimed in any of claims 20 to 23 wherein at least part of one surface of the glazing is exposed to a plasma treatment process causing the inorganic polymer (2) to decompose to its inorganic oxide.

25. A method as claimed in claim 24 when dependent on claim 23 wherein the inorganic oxide is silica.



Fig.1.

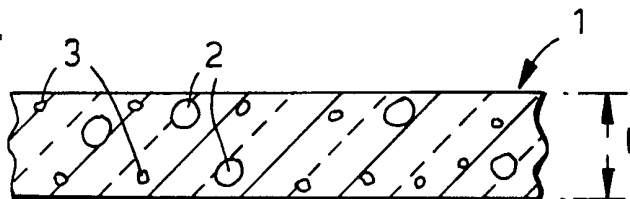

Fig.2.

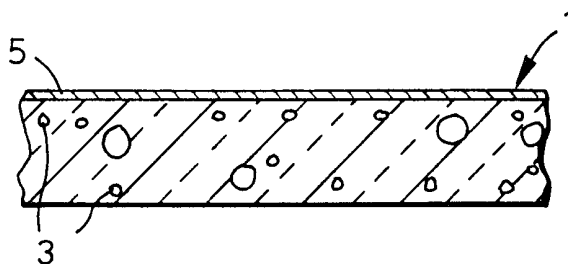

Fig.3.

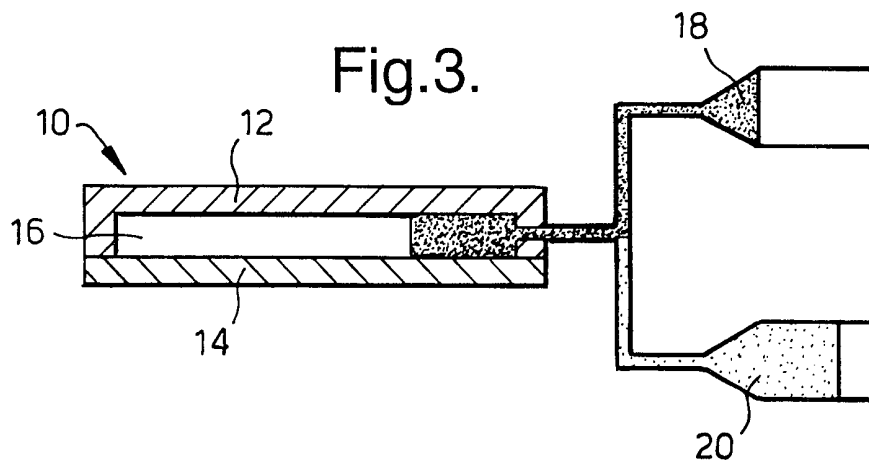

Fig.4.

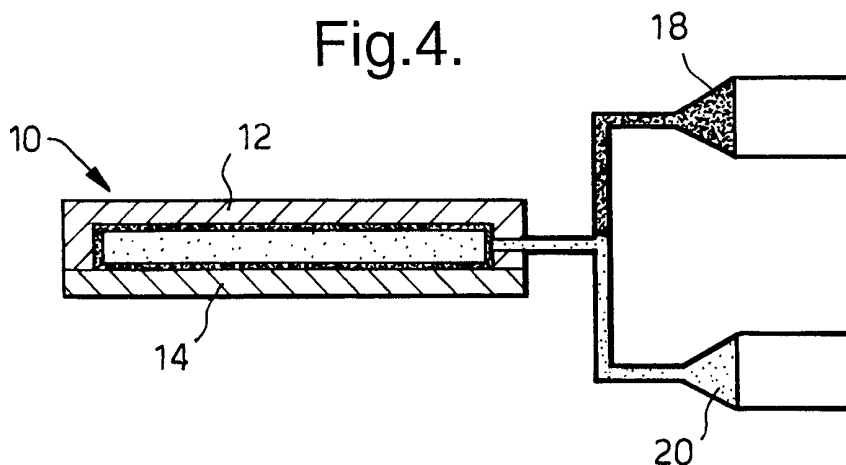

Fig.5.

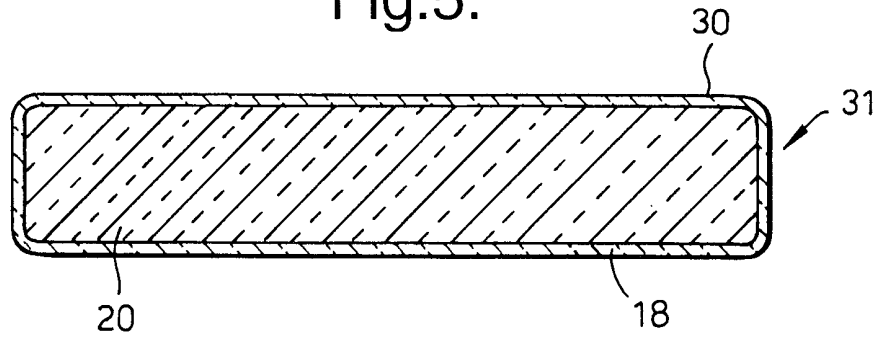

Fig.6.

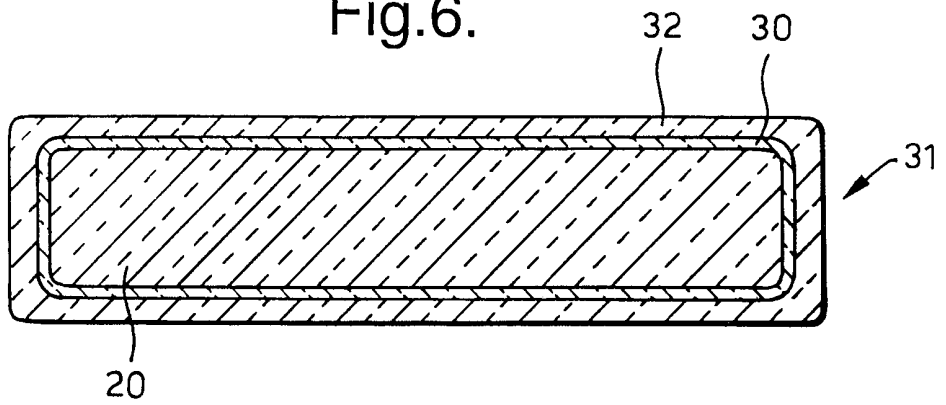
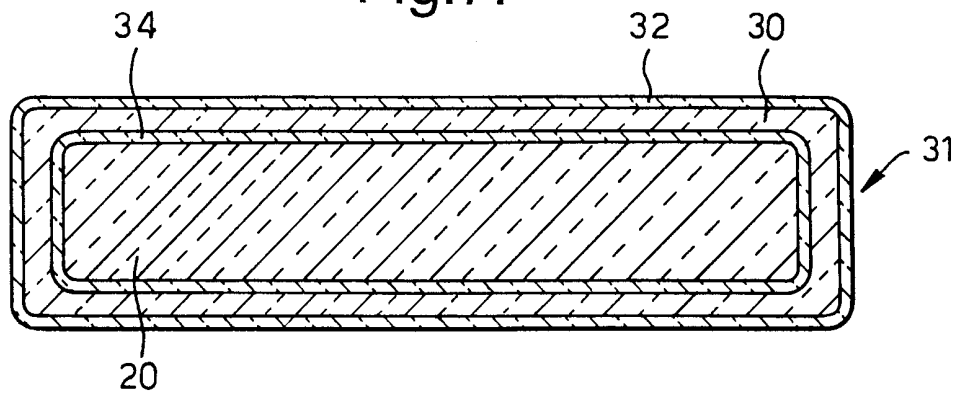

Fig.7.



# INTERNATIONAL SEARCH REPORT

International Application No  
PCT/GB 99/02414

**A. CLASSIFICATION OF SUBJECT MATTER**  
IPC 7 C08J/04 C09D183/04 G02B1/10

According to International Patent Classification (IPC) or to both national classification and IPC

**B. FIELDS SEARCHED**

Minimum documentation searched (classification system followed by classification symbols)

IPC 7 C08J C09D G02B

Documentation searched other than minimum documentation to the extent that such documents are included in the fields searched

Electronic data base consulted during the international search (name of data base and, where practical, search terms used)

**C. DOCUMENTS CONSIDERED TO BE RELEVANT**

Category	Citation of document, with indication, where appropriate, of the relevant passages	Relevant to claim No.
X	US 4 374 158 A (TANIGUCHI TAKASHI ET AL) 15 February 1983 (1983-02-15) claims 1-19 column 4, line 60 -column 5, line 44 column 7, line 9 - line 42 column 7, line 53 -column 8, line 8 ---	1-10
X	US 5 385 955 A (TARSHIANI YASSIN Y ET AL) 31 January 1995 (1995-01-31) claim 1 column 2, line 13 - line 27 column 4, line 30 - line 39 ---	1,3,4
A	US 5 654 090 A (KAYANOKI HISAYUKI) 5 August 1997 (1997-08-05) claims 1-5 ---	1-10
	-/--	

Further documents are listed in the continuation of box C.

Patent family members are listed in annex.

° Special categories of cited documents :

- "A" document defining the general state of the art which is not considered to be of particular relevance
- "E" earlier document but published on or after the international filing date
- "L" document which may throw doubts on priority claim(s) or which is cited to establish the publication date of another citation or other special reason (as specified)
- "O" document referring to an oral disclosure, use, exhibition or other means
- "P" document published prior to the international filing date but later than the priority date claimed

- "T" later document published after the international filing date or priority date and not in conflict with the application but cited to understand the principle or theory underlying the invention
- "X" document of particular relevance; the claimed invention cannot be considered novel or cannot be considered to involve an inventive step when the document is taken alone
- "Y" document of particular relevance; the claimed invention cannot be considered to involve an inventive step when the document is combined with one or more other such documents, such combination being obvious to a person skilled in the art.
- "&" document member of the same patent family

Date of the actual completion of the international search  <b>18 October 1999</b>	Date of mailing of the international search report  <b>28/10/1999</b>
Name and mailing address of the ISA European Patent Office, P.B. 5818 Patentlaan 2 NL - 2280 HV Rijswijk Tel. (+31-70) 340-2040, Tx. 31 651 epo nl, Fax: (+31-70) 340-3016	Authorized officer  <b>Depijper, R</b>

# INTERNATIONAL SEARCH REPORT

International Application No

PCT/GB 99/02414

**C.(Continuation) DOCUMENTS CONSIDERED TO BE RELEVANT**

Category °	Citation of document, with indication, where appropriate, of the relevant passages	Relevant to claim No.
A	GB 2 010 879 A (DOW CORNING) 4 July 1979 (1979-07-04) claim 1 page 2, line 7 - line 16 -----	1
A	EP 0 266 225 A (HASHIMOTO FORMING KOGYO CO) 4 May 1988 (1988-05-04) claims 1-4 page 2, line 30 -page 3, line 6 -----	1
A	WO 96 07525 A (ROVER GROUP ;SMITH GORDON FREDERICK (GB)) 14 March 1996 (1996-03-14) cited in the application claims 1-22 -----	1
A	EP 0 101 326 A (FOSTER GRANT CORP) 22 February 1984 (1984-02-22) claims 1,5,6 page 1, line 1 - line 7 page 8, line 27 -page 9, line 6 page 9, line 18 - line 38 -----	6

# INTERNATIONAL SEARCH REPORT

Information on patent family members

International Application No

PCT/GB 99/02414

Patent document cited in search report	Publication date	Patent family member(s)	Publication date
US 4374158     A	15-02-1983	JP 1341773 C	14-10-1986
		JP 57047330 A	18-03-1982
		JP 61006089 B	24-02-1986
		JP 1426233 C	25-02-1988
		JP 56084729 A	10-07-1981
		JP 60059250 B	24-12-1985
		DE 3042770 A	04-06-1981
		FR 2470977 A	12-06-1981
		GB 2064987 A, B	24-06-1981
US 5385955     A	31-01-1995	DE 69317121 D	02-04-1998
		DE 69317121 T	29-10-1998
		WO 9410230 A	11-05-1994
		EP 0667880 A	23-08-1995
		ES 2114162 T	16-05-1998
US 5654090     A	05-08-1997	CN 1113509 A	20-12-1995
		DE 19511627 A	12-10-1995
		FR 2718457 A	13-10-1995
		JP 7325201 A	12-12-1995
		US 5858077 A	12-01-1999
GB 2010879     A	04-07-1979	BE 873005 A	22-06-1979
		CA 1116771 A	19-01-1982
		DE 2855792 A	28-06-1979
		FR 2412595 A	20-07-1979
		JP 56041267 A	17-04-1981
		JP 1075857 C	25-12-1981
		JP 54087736 A	12-07-1979
		JP 56018626 B	30-04-1981
		US 4197230 A	08-04-1980
		US 4223072 A	16-09-1980
EP 0266225     A	04-05-1988	JP 63114957 A	19-05-1988
		AU 577986 B	06-10-1988
		AU 8014487 A	26-05-1988
WO 9607525     A	14-03-1996	AU 3394795 A	27-03-1996
		GB 2305890 A, B	23-04-1997
		GB 2319744 A, B	03-06-1998
EP 0101326     A	22-02-1984	US 4435476 A	06-03-1984
		NL 8320282 A	02-07-1984
		NL 8320282 T	02-07-1984
		AT 904683 A	15-05-1991
		AT 904783 A	15-05-1991
		CA 1206117 A	17-06-1986
		CA 1204701 A	20-05-1986
		DE 3390170 T	20-09-1984
		DE 3390171 T	06-09-1984
		EP 0102224 A	07-03-1984
		EP 0118527 A	19-09-1984
		EP 0116091 A	22-08-1984
		GB 2135213 A	30-08-1984
		GB 2135214 A, B	30-08-1984
		JP 59501668 T	04-10-1984
		NL 8320283 T	02-07-1984
		WO 8400721 A	01-03-1984

# INTERNATIONAL SEARCH REPORT

Information on patent family members

International Application No

PCT/GB 99/02414

Patent document cited in search report	Publication date	Patent family member(s)	Publication date
EP 0101326 A		WO 8400722 A	01-03-1984
		US 4503126 A	05-03-1985
		US 4492733 A	08-01-1985
-----			