

Fig. 3

Description

[0001] The present invention relates to a water dispensing device, specifically to a shower arm of a shower unit.

[0002] The shower sector is continuously developing and changing, and is particularly focused on arousing the purchaser's interest with unusual designs and surprising water plays, for example consisting in unusual forms of the jet of water dispensed.

[0003] For example, shower heads able to dispense jets of water having different shapes and characteristics have recently become quite widespread, such as spray jets of varying intensity, flat jets and similar.

[0004] One example of embodiment of a shower dispensing four different jets is described in the European patent application EP-A1-1647333 in the name of the Applicant.

[0005] In the case of shower arms fixed to the wall at a predefined height, it would be extremely inconvenient to have to adjust the shower arm to choose the type of jet desired, for example by turning the shower head.

[0006] A shower arm is however known which has on its lower surface, facing the user, three mouths: the first for a spray jet, the second for four aligned jets and the third for a flat jet; respective wall-mounted knobs are provided for the three jets: each knob corresponding to one jet.

[0007] However such solution presents a number of drawbacks, in that a water supply system for distributing the water to several knobs is required to supply the shower arm.

[0008] The purpose of the present invention is to make a wall-mounted shower arm with a number of jets which is particularly easy to use and such as to avoid the predisposition of a complex water supply system.

[0009] Such purpose is achieved by a shower arm made according to claim 1 below. The dependent claims describe embodiment variations.

[0010] The characteristics and advantages of the shower arm according to the present invention will be evident from the description below, made by way of an indicative and non-limiting example, according to the attached figures, wherein:

[0011] - figure 1 shows a shower arm according to the present invention from a point of observation underneath it, in a raised configuration;

[0012] - figure 2 shows the shower arm of figure 1, from a point of observation above it;

[0013] - figure 3 shows the shower arm of figure 1, in a lowered configuration;

[0014] - figure 4 shows the shower arm of figure 1, without the cover;

[0015] - figure 5 shows a front view of the shower arm in figure 1;

[0016] - figure 6 shows a cross-section view of the shower arm in figure 1, according to the cross-section line VI-VI in figure 5;

[0017] - figure 7 shows a cross-section view of the shower arm in figure 1, according to the cross-section line VII-VII in figure 5;

[0018] - figure 8 shows a front view of the shower arm in figure 3;

[0019] - figure 9 shows a cross-section view of the shower arm of figure 3, according to the cross-section line IX-IX in figure 8;

[0020] - figures 10a and 10b show a deviator device of the shower arm, from two different observation points;

[0021] - figure 11 shows a view of the shower arm in separate parts;

[0022] - figures 12a to 14 show further embodiment variations of the dispenser device.

[0023] The present invention refers to a water dispensing device in general and merely for clarity of explanation will reference be subsequently made to a shower arm; the device described is, however, suitable for use as a dispenser device for baths, basins and similar.

[0024] With reference to the attached figures reference numeral 1 is used to globally denote a shower arm suitable for attaching to the wall, for example of a bathroom, at the desired height.

[0025] The shower arm 1 comprises a plate 2 designed to lie against the surface of the wall and to acts as a support plate for the components of the shower arm, as described below.

[0026] The shower arm 1 also comprises a casing 4 resting against the plate 2, preferably attached to the wall by means of screws 6 which go through the wall of the casing and of the plate 2.

[0027] Further, the shower arm 1 comprises a manifold 7 in the form of a tube, which couples with the casing 4 for support, designed to be connected to the water supply.

[0028] The shower arm 1 comprises, in addition, a head 8 extending mainly along a head axis X.

[0029] The head 8, for example, box-shaped, for example with a rectangular cross-section, has a lower surface 10 and an opposite upper surface 12.

[0030] The head 8 is hinged to the manifold 7 so that it can be turned around a rotation axis Y parallel to the attachment wall, from a lowered configuration, in which the lower side 10 faces the wall (figure 3), and a raised configuration (figure 1).

[0031] The head 8 has, on the lower surface 10, a lower dispensing area 14 for dispensing a first jet of water, for example a spray; for example, the lower dispensing area comprises a number of nozzles 16, protruding from the lower surface 10, from each of which a trickle of water comes out.

[0032] According to a preferred embodiment, the nozzles are arranged in parallel lines, covering a rectangular area.

[0033] In one embodiment variation, the nozzles are arranged over a circular or ovoid area.

[0034] The head 8 also has, on the upper surface 12, an upper dispensing area 18 for dispensing a further jet

of water, for example a flat jet.

[0035] Preferably, the upper dispensing area 18 comprises a slit 20, for example parallel to the rotation axis of the head, from which the flat jet is dispensed.

[0036] According to a preferred embodiment, the shower arm 1 comprises means of assistance of rotation able to facilitate rotation of the head 8 from the lowered configuration to the raised configuration.

[0037] For example, said means of assistance comprise a pair of gas springs 22, attached at one end to the plate 2 and at the other to the head 8, at points defining a spring axis parallel to the rotation axis Y, but separate from it.

[0038] In the lowered configuration, the gas springs, while constantly influencing the head, produce no effect by being beyond the limit return point. When the head is grasped and rotation of the same commenced, the springs pass the limit return point and act on the head 8 making it turn towards the raised configuration.

[0039] The shower arm 1 comprises, in addition, a cover 30, applied to the plate 2, so as to cover the gas springs 22 too.

[0040] Said cover, in the area underneath the head 8, when the latter is in a raised configuration, has a housing compartment 32, where a portion of the head 8 is housed when the head is in the lowered configuration (figure 3).

[0041] In addition, the shower arm 1 comprises deviator devices able to alternately channel the water to the lower dispensing area 14 or upper dispensing area 18, said deviator devices being influenced in their channelling by the rotation of the head.

[0042] For example, the shower arm 1 comprises at least one deviator device 40, joined to the head 8 and partially lodged in it, able to channel the water towards the lower dispensing area 14, when the head is in the raised configuration, or towards the upper dispensing area 18, when the head is in the lowered configuration, being moved in relation to the manifold 7, to which it is coupled, by virtue of the rotation of the head 8.

[0043] In the embodiment shown, two deviator devices 40 are provided, one on the right side of the arm (looking at the wall), and the other on the left side, so as to create a symmetrical structure in relation to a plane passing through the centreline of the head.

[0044] Advantageously this makes it possible to achieve a high degree of uniformity of the jets dispensed.

[0045] According to a preferred embodiment, the deviator device 40 comprises an obturator 42 and a feeder mechanism 44 which can be connected to the obturator 42.

[0046] The obturator 42 is essentially a cylindrical shape, with its axis coinciding with the rotation axis Y of the head, while the feeder mechanism 44 has a lengthened shape in the direction of the head axis X of the head 8.

[0047] The deviator 42, on the base facing the manifold 7, has a separate lower mouth entrance 48a and upper mouth entrance 48b, and a lower mouth exit 50a, fluidly

connected with the lower mouth entrance 48a, and an upper mouth exit 50b, fluidly connected with the upper mouth entrance 48b.

[0048] The lower mouth exit 50a and the upper mouth exit 50b are connected to their respective entrances 48a, 48b by respective conduits inside the obturator, which have a section parallel to the rotation axis Y and a section parallel to the head axis X, to deviate the flow of water coming out of the manifold.

[0049] The feed mechanism 44 comprises a lower mouth tube 52a and an upper mouth tube 52b, stretching along the head axis X of the head 8.

[0050] The feed mechanism 44 couples to the obturator 42, so that the lower mouth exit 50a is connected to the lower mouth tube 52a and the upper mouth exit 50b is connected to the upper mouth tube 52b.

[0051] The lower mouth tube 52a is connected to the lower dispensing area 14, so as to supply water for a spray jet, while the upper mouth tube is connected to the upper dispensing area 18, so as to supply water for a flat jet.

[0052] The manifold 7 has a supply duct 60 designed for connection to the water supply, for example by means of a spigot 62.

[0053] The supply duct 60 extends inside the manifold 7 to give on to a surface to which said obturator 42 is coupled.

[0054] For example, the supply duct 60 divides into a right branch which gives onto a right opening on the right side 64' of the casing 4 and into a left branch which gives onto a left opening on a left side 64'' of the casing 4.

[0055] Respective obturators 42 are coupled to the right side 64' and to the left side 64'', so as to be in contact with the same.

[0056] When the head 8 is in the raised configuration, the lower mouth entrance 48a of the obturator 42 lies at least partially over the right opening of the right branch of the supply duct 60, while the upper mouth entrance 48b of the obturator 42 is completely disconnected from said right opening. The same happens on the left side.

[0057] In said configuration, the water supplied from the water supply through the obturator 42 coming out of the lower mouth exit 50a, passes through the lower mouth tube 52a of the feed mechanism 44 and is fed to the lower dispensing area 14, making a first jet, for example a spray jet.

[0058] From the upper area 18 no jet is dispensed however, in that no water is fed towards the upper mouth exit 50b of the obturator 42.

[0059] When the head 8 is in the lowered configuration, the upper mouth entrance 48b of the obturator 42 lies at least partially over the right opening of the right branch of the supply duct 60, while the lower mouth entrance 48a of the obturator 42 is completely disconnected from said right opening. The same happens on the left side.

[0060] In said configuration, the water supplied from the water supply through the obturator 42 coming out of the upper mouth exit 50b, passes through the upper

mouth tube 52b of the feed mechanism 44 and is fed to the upper dispensing area 18, making a further jet, for example a flat jet.

[0061] From the lower area 14, looking onto the wall, no jet is dispensed however, in that no water is fed towards the lower mouth exit 50a of the obturator 42.

[0062] According to a preferred embodiment, for dispensing of the jet from the lower dispensing area 14 a dispensing plate 70 is provided, lodged in the head 8, perforated where the nozzles 16 are, and a counter plate 72, is laid over the dispensing plate 70, but distanced from it so as to form a cavity 72.

[0063] Preferably, between the plate 70 and the counter plate 72 there is a membrane 73 holding the nozzles 16.

[0064] Furthermore, a final tube 76 is provided, for example made in one piece with the counter-plate 72, able to connect with the lower mouth tube 52a of the feed mechanism 44.

[0065] The water going through the lower mouth tube 52a passes into the final tube 76 and from here flows into the cavity 74, which it comes out of through the nozzles.

[0066] According to a preferred embodiment, for dispensing of the water from the upper dispensing area 18, there is a balancing chamber 80, open at the slit 20, defined by a folded wall 82, which engages with the pair of feed mechanisms 44.

[0067] Specifically, said feed mechanism 44 comprises a lateral wall 84, protruding laterally from the tubes 52a, 52b; the upper mouth tube 52b opening inside the lateral wall 84.

[0068] The folded wall 82 engages on both sides with the lateral walls 84 of the two feed mechanisms 44, thus defining the balancing chamber 80.

[0069] Said chamber has a sinuous-shaped opening of the upper mouth tube 52b towards the slit 20, in other words first rounded and wide, subsequently narrow and then wide again at the slit 20.

[0070] Advantageously, said chamber forms a sort of lung which absorbs the movements and vortexes of the water pouring from the upper mouth tube 52b to the chamber 80, thus obtaining a particularly regular flat spray.

[0071] According to a preferred embodiment, the shower arm 1 comprises a drainage mechanism able to drain off the residual water into the balancing chamber 80.

[0072] Said drainage mechanism can be activated by rotation of the head 8.

[0073] For example, the drainage mechanism comprises a duct 90 connecting the balancing chamber and the lower surface 10 of the head and a spring obturator 92, positioned at the exit of the duct 90 on the lower surface 10.

[0074] When the head is in the raised configuration, the spring obturator 92 is stressed by the spring and leaves the duct 90 open towards the lower surface 10, so that any water remaining in the balancing chamber 80

can be drained.

[0075] When the head is in the lowered configuration, the spring obturator 92 strikes against the wall which defines the compartment 32 of the cover 30 and is flattened, closing the duct 90.

[0076] According to an embodiment variation, the dispensing device 1 comprises at least one light source, for example for the embodiment of a colour therapy device (figures 12a and 12b).

[0077] Preferably, the light source is lodged in the cover 30 and said cover 30 comprises at least one portion of cover 30' transparent to the light emitted by the source, for example made in etched glass. The portion of cover 30' for example looks onto the head 8 when this is in the lowered configuration.

[0078] Preferably, the light source comprises a number of LEDs 100, for example supported under the cover 30 by means of a support plate 102, for example inclined.

[0079] Preferably, the LEDs are of different colours and can be controlled separately, so as to vary the colour of the light emitted.

[0080] According to yet a further embodiment variation, the device 1 comprises an acoustic source, for example operatively connected to a digital music player, radio and similar (figure 13).

[0081] In such variation, preferably, a portion of the cover 30" of the cover 30 has apertures for sound emission.

[0082] According to yet a further embodiment variation, the device 1 comprises a source of fragrances, to emanate a perfume, automatic or controlled by the user (figure 14).

[0083] In such variation, preferably, a portion of the cover 30''' of the cover 30 has apertures for emission of the fragrances.

[0084] Innovatively, the dispensing device according to the present invention, specifically utilisable as a shower arm, makes it possible to obtain different jets, specifically of a different shape, without installing a complicated water supply system to the arm.

[0085] Advantageously, in addition, the device is easy to use, in that it enables the user to change from one type of jet to another merely by lowering the head of the device, exploiting the lever effect.

[0086] According to a further advantageous aspect, raising the head is particularly easy, given that it is assisted by a gas spring.

[0087] According to yet a further advantageous aspect, the flat jet is particularly regular, the turbulence having been eliminated from the flow of water.

[0088] Advantageously, the stagnation of water in the supply ducts towards the upper dispensing area is avoided, when it is not used.

[0089] According to a further advantageous aspect, the fabrication of the device is economical given the small number of components.

[0090] It is clear that a person skilled in the art may

make modifications to the device described above so as to satisfy contingent requirements, while remaining within the scope of protection of the invention as defined by the appended claims.

Claims

1. Dispensing device (1), specifically a shower arm, comprising:
 - a head (8) extending mainly along a head axis (X), having a lower surface (10) fitted with a lower dispensing area (14) for dispensing a jet of water and an opposite upper surface (12) fitted with an upper dispensing area (18) to dispense a further jet of water, said head being supported by a wall so that it can rotate from a lowered configuration wherein the lower surface faces the wall, and a raised configuration;
 - deviator devices able to alternately channel the water to the lower dispensing area (14) or to the upper dispensing area (18), said deviator devices being influenced in their channelling effect by rotation of the head.
2. Device according to claim 1, comprising a fixed manifold (7), with a single input for connection to the water supply and fitted with at least one opening for the output of the water and wherein the deviator devices comprise at least one deviator device (40) comprising an obturator (42) joined in rotation to the head (8), said obturator being fitted with a lower mouth entrance (48a) and an upper mouth entrance (48b), alternately positioned over the opening of the water output of the manifold by rotation of the head (8).
3. Device according to claim 2, comprising two deviator devices (40), positioned to the right and to the left of the manifold (7).
4. Device according to claim 2 or 3, wherein the obturator (42) has a lower mouth exit (50a) and an upper mouth exit (50b) connected to the respective entrances (48a, 48b) by respective conduits inside the obturator, said conduits having a section parallel to the rotation axis (Y) and a section parallel to the head axis (X), to deviate the flow of water coming out of the manifold.
5. Device according to claim 5, wherein the deviator device (40) comprises a feed mechanism (44) lodged in the head (8), having an upper mouth tube (52b) and a lower mouth tube (52a), lengthened along the head axis (X), respectively connected to the lower dispensing area (14) and the upper dispensing area (18).
6. Device according to claim 5, comprising a plate (70) lodged in the head (8), a membrane (73) positioned on said plate, fitted with nozzles (16) which protrude from the plate (70) and form said lower dispensing area (14), and a counter-plate (72), laid over the plate (70) to form a cavity (74) with it, said lower mouth tube (52a) being in fluid communication with said cavity, to drain the water into it and form the first jet.
7. Device according to claim 5 or 6, comprising a folded wall (82) lodged in the head (8), which defines a balancing chamber (80) open in the upper dispensing area (18), said balancing chamber being in communication with the upper mouth tube (52b) of the feed mechanism (44).
8. Device according to claim 7, wherein said balancing chamber is sinuous.
9. Device according to claim 7 or 8, comprising drainage means able to drain off the residual water in the balancing chamber when the head is in the raised configuration, activated by rotation of the head.
10. Device according to any of the previous claims, comprising means of assistance to the rotation able to influence the head (8) to facilitate rotation from the lowered configuration to the raised configuration.
11. Device according to claim 10, wherein said means of assistance comprise at least one gas spring (22) connected to a fixed plate and to said head.
12. Device according to any of the previous claims, comprising a plate (2) for attachment to the wall and a cover (30) placed over the plate to hide it from view.
13. Device according to any of the previous claims, wherein the head (8) is a box-shaped body with rectangular cross-section in relation to a plane perpendicular to the head axis (8).
14. Device according to any of the previous claims, wherein the lower dispensing area is suitable for dispensing a spray jet formed of a number of trickles of water.
15. Device according to any of the previous claims, wherein the upper dispensing area is suitable for dispensing a flat jet through a slit (20).
16. Device according to any of the previous claims, comprising at least one light source.
17. Device according to any of the previous claims, comprising at least one acoustic source.
18. Device according to any of the previous claims, com-

prising at least one source of fragrant aromas.

5

10

15

20

25

30

35

40

45

50

55

7

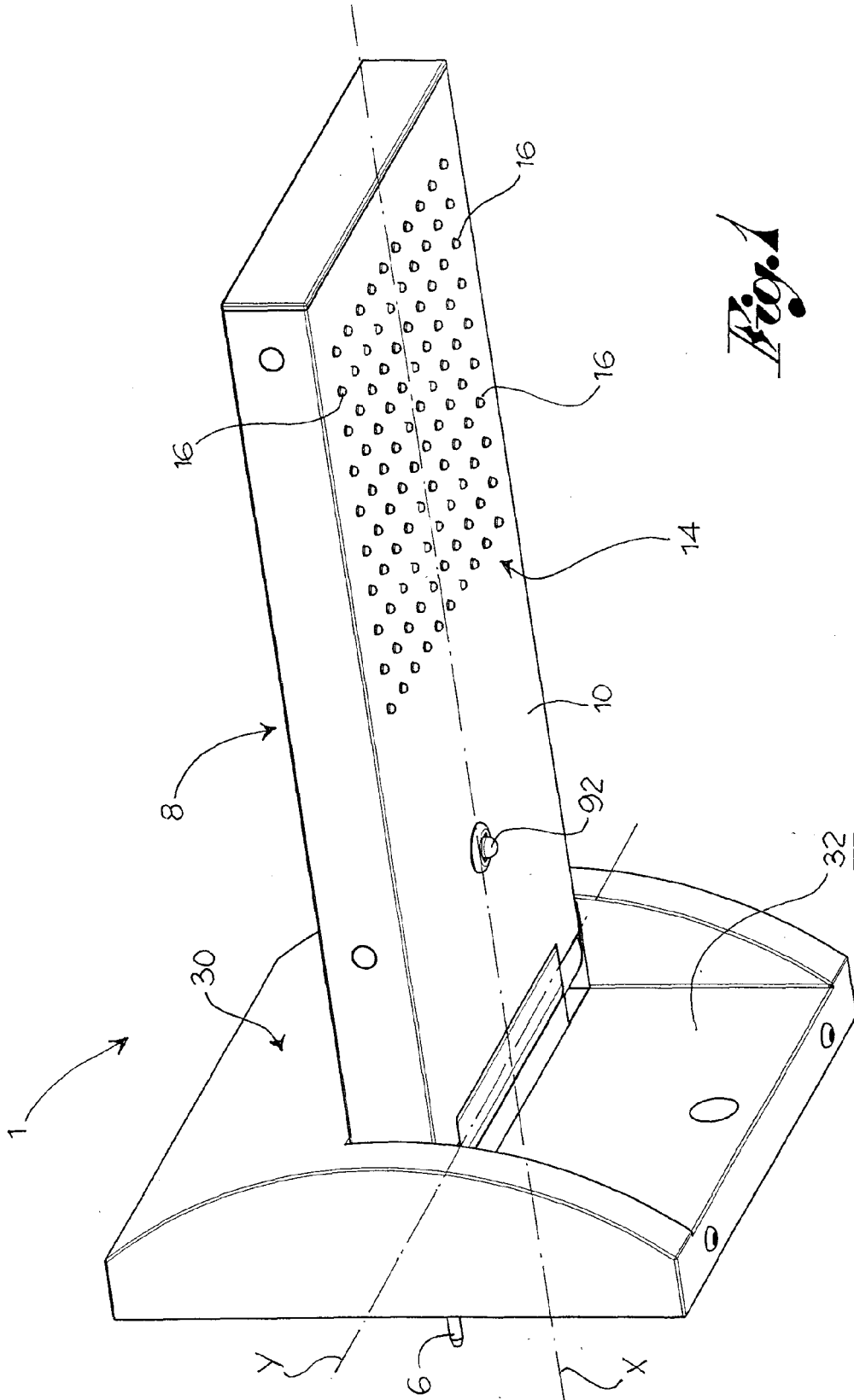

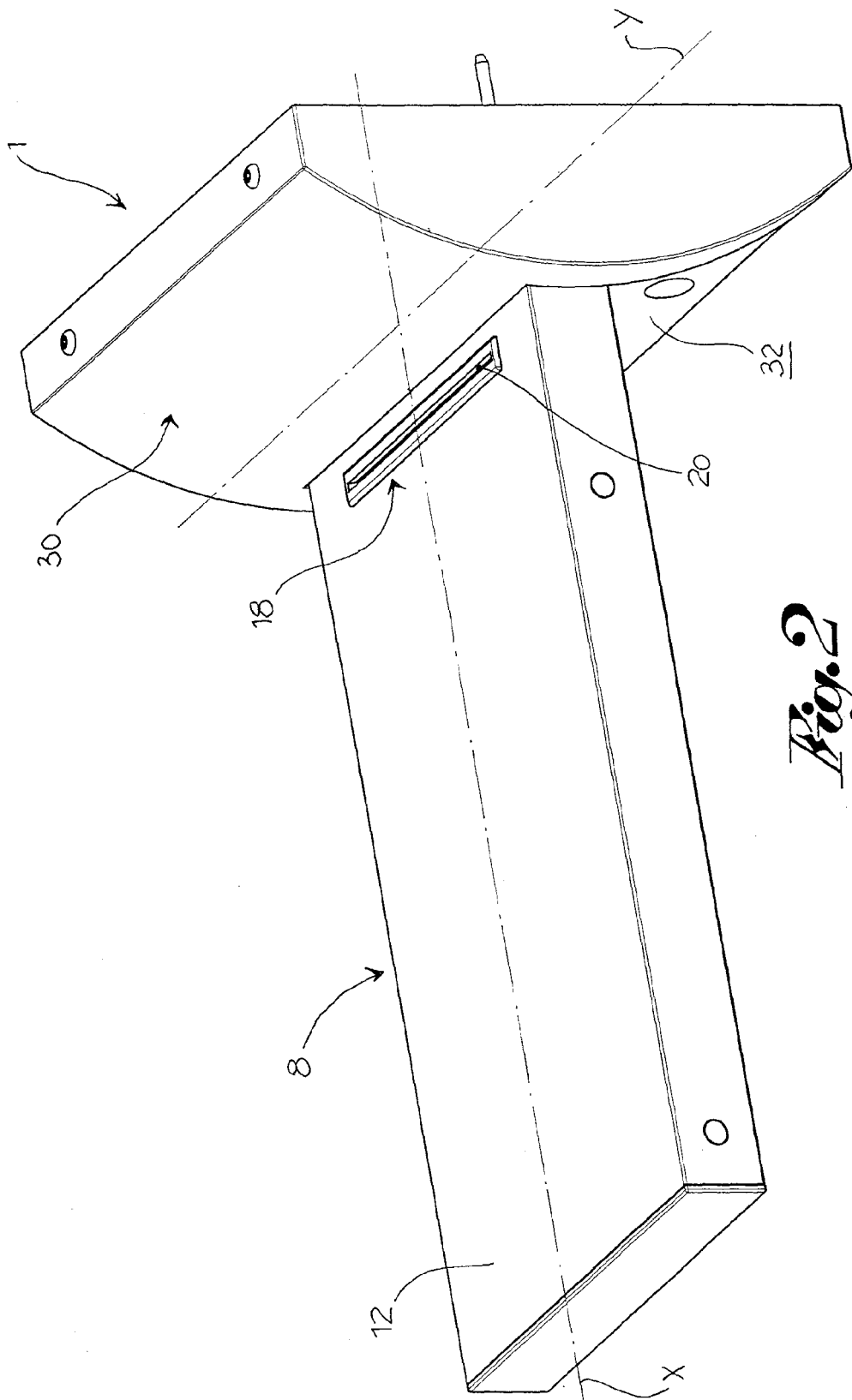

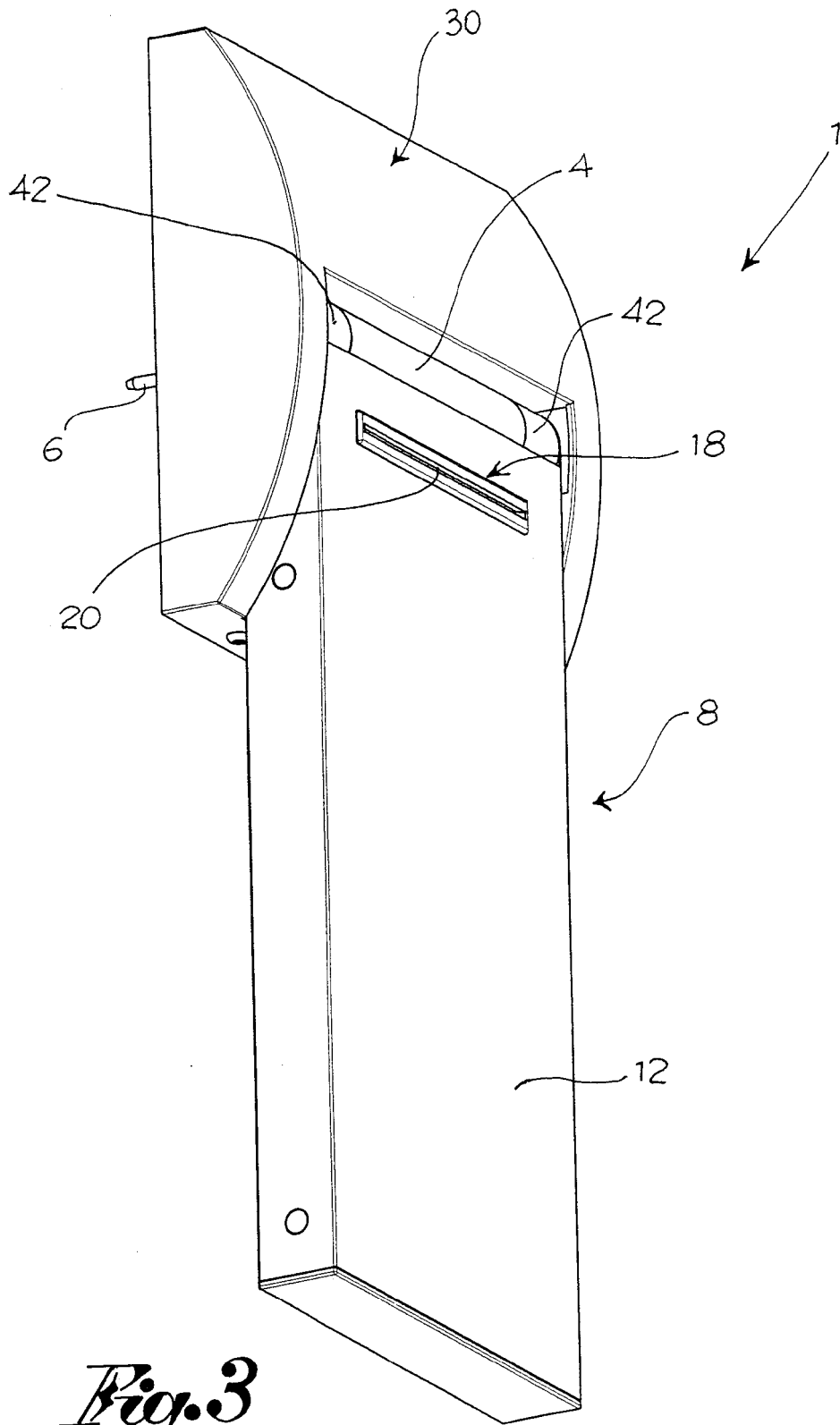

Fig. 3

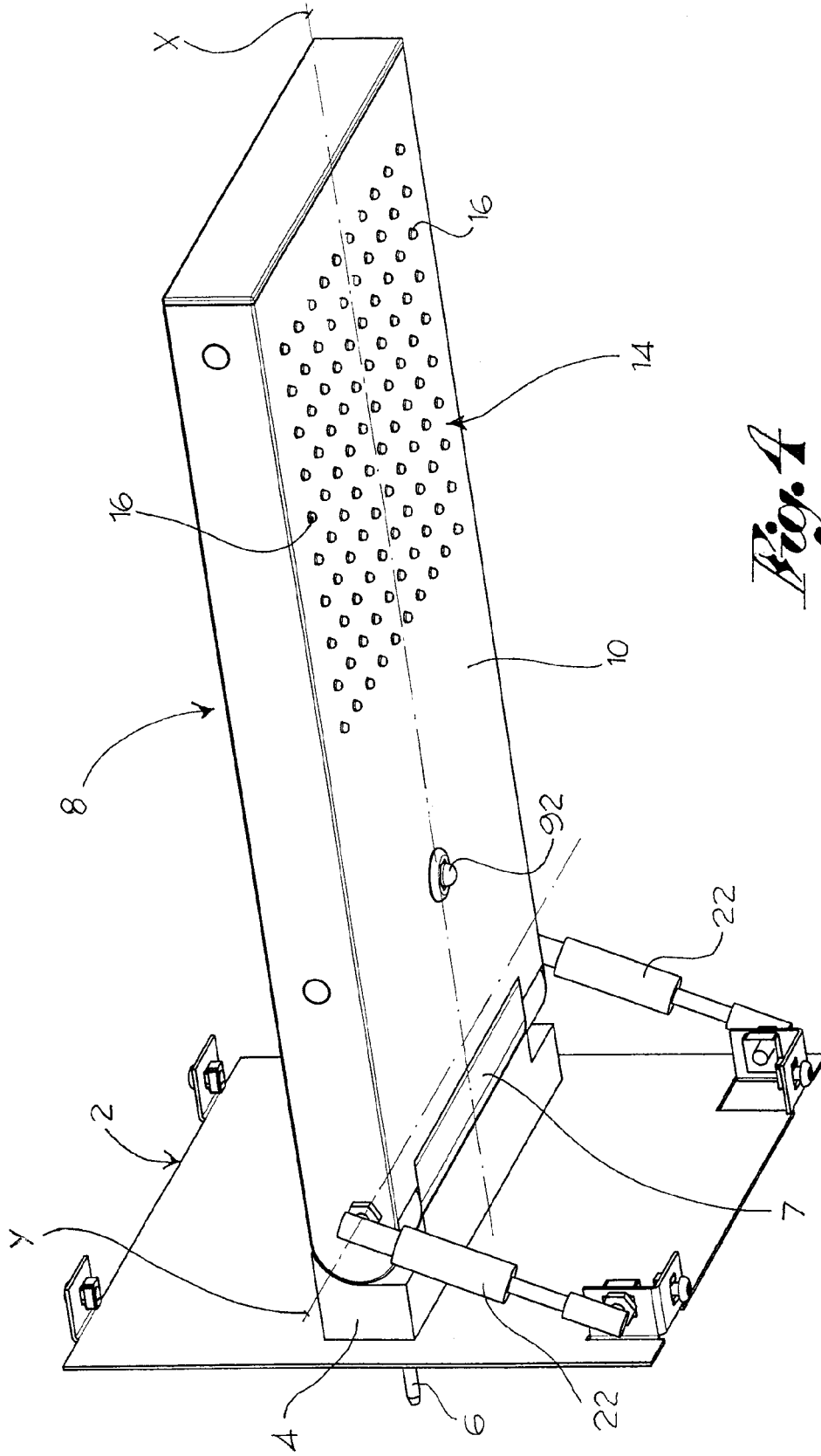

Fig. 1

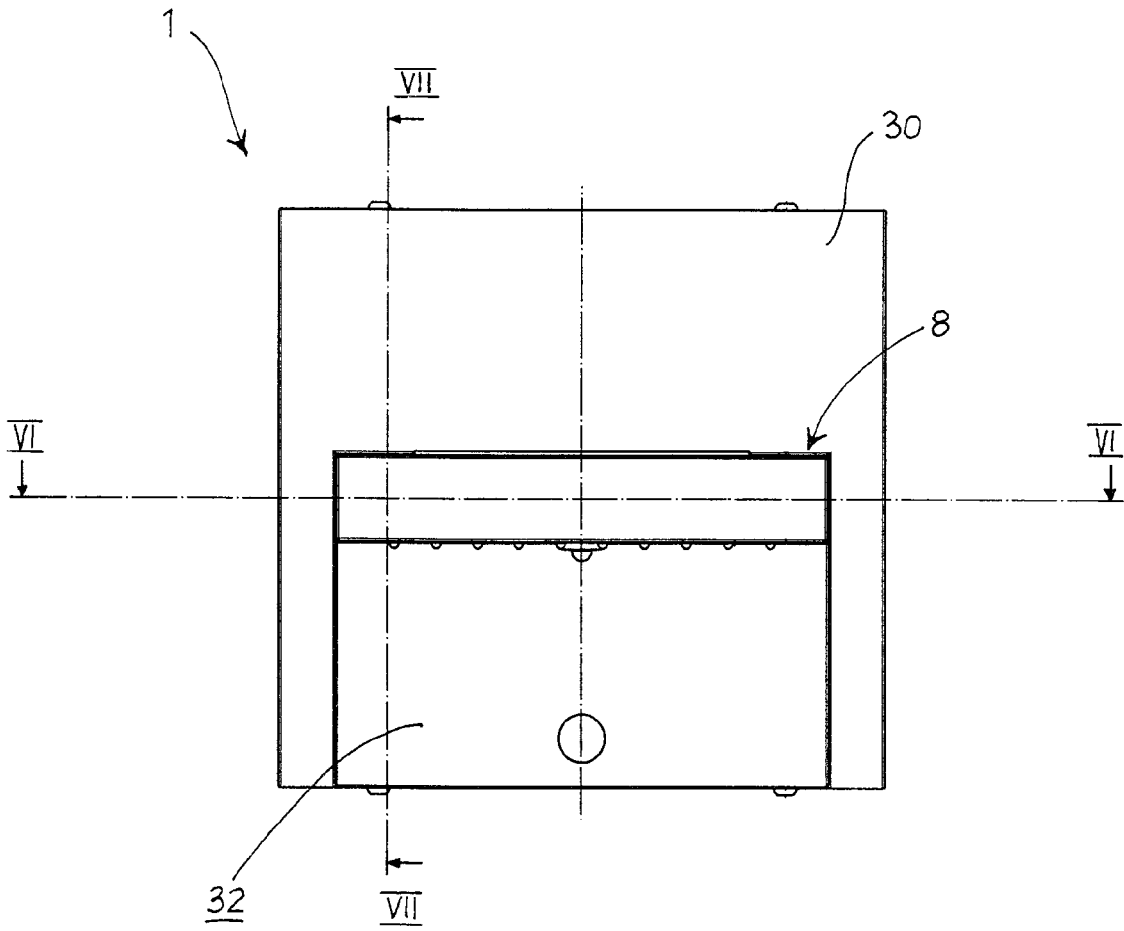

Fig. 5

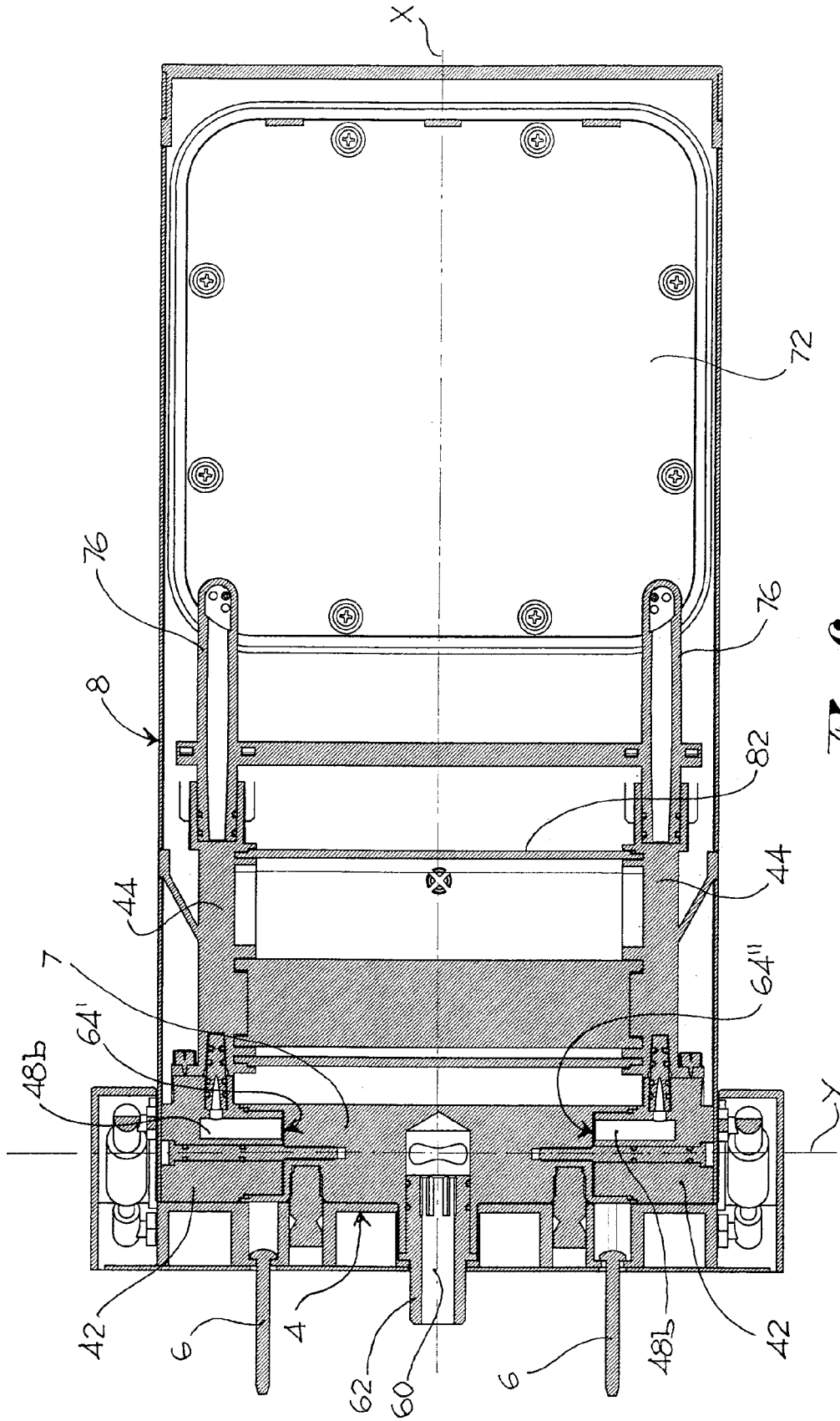

Fig. 6

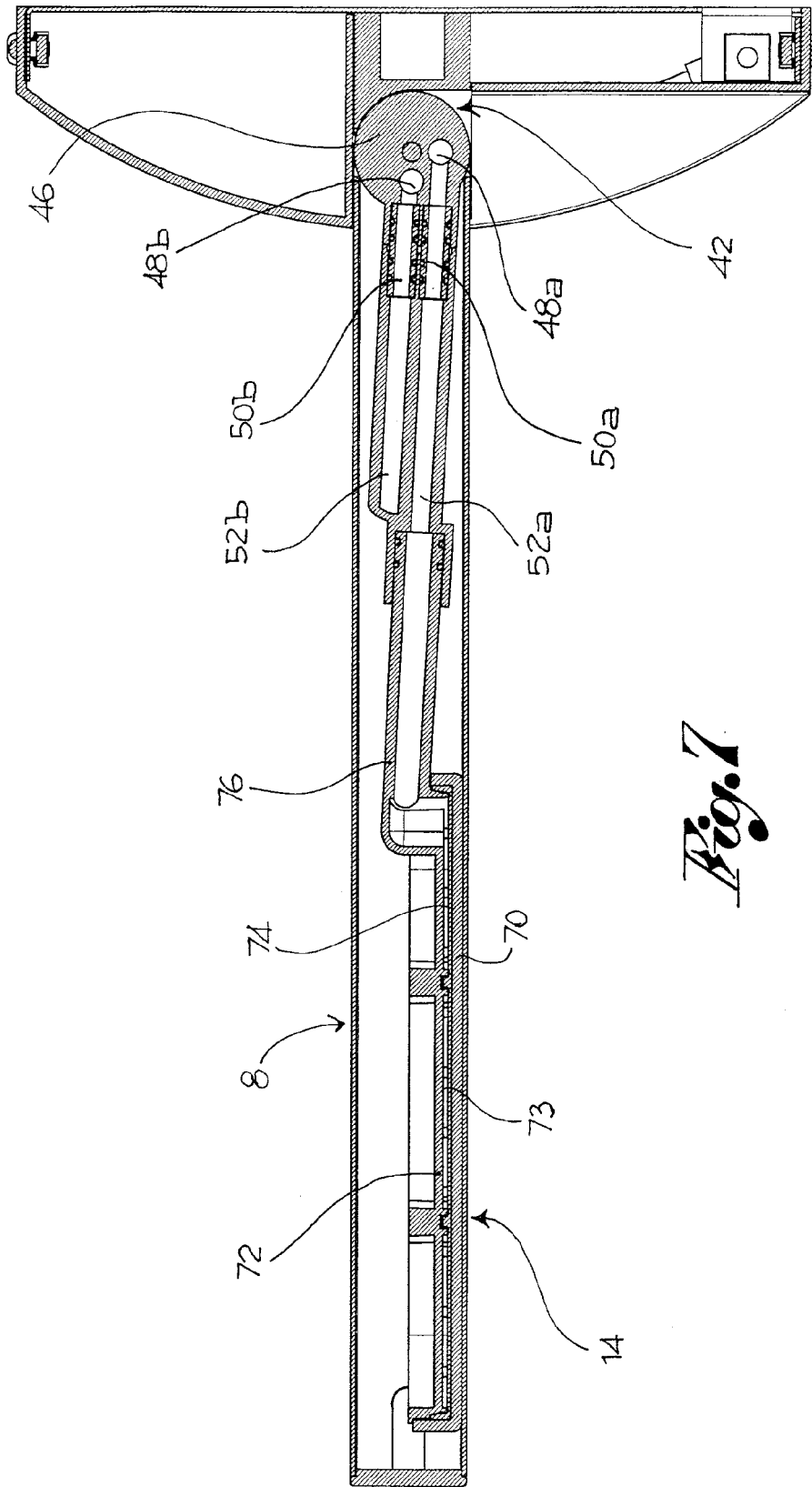

Fig. 7

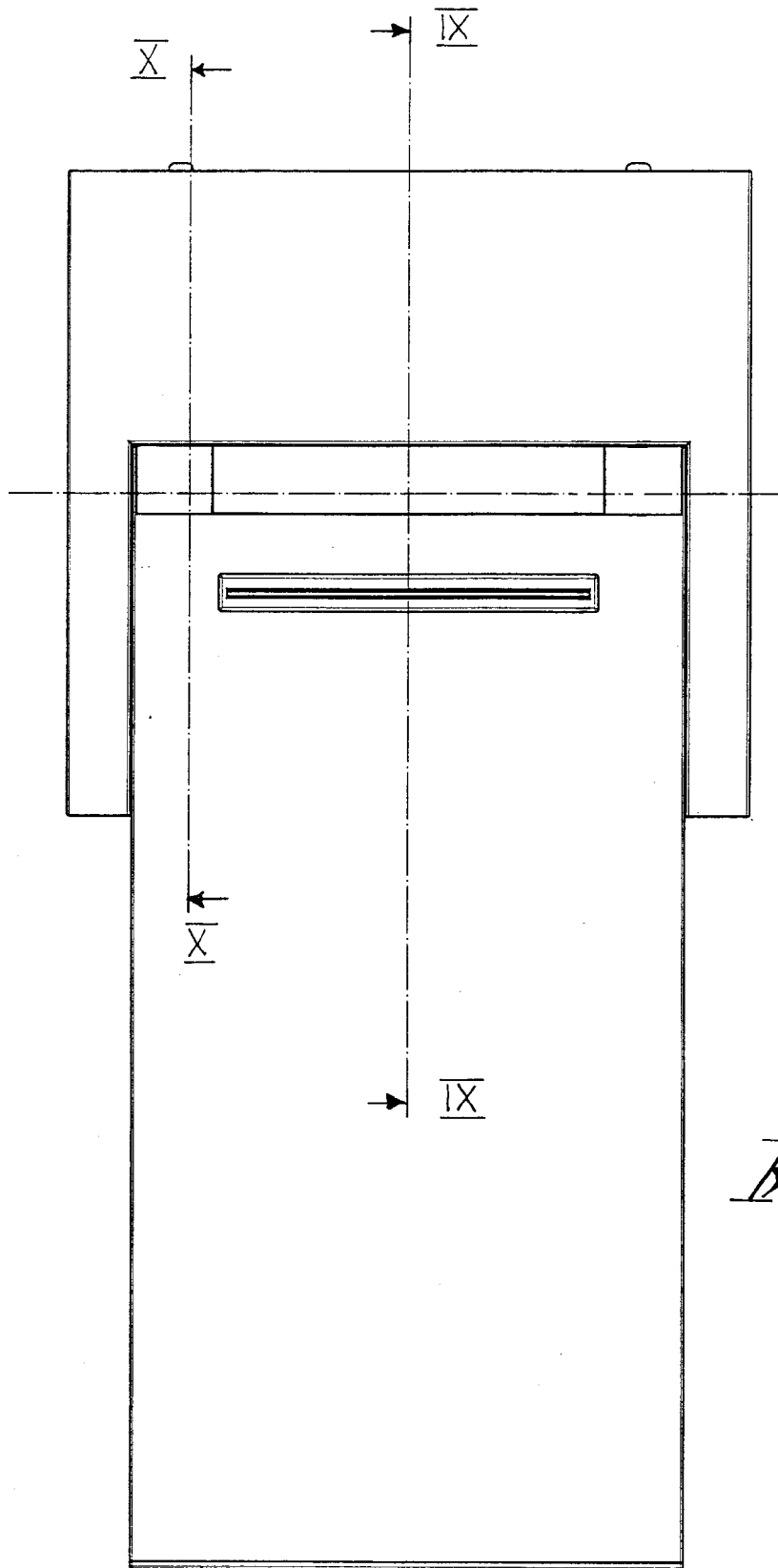
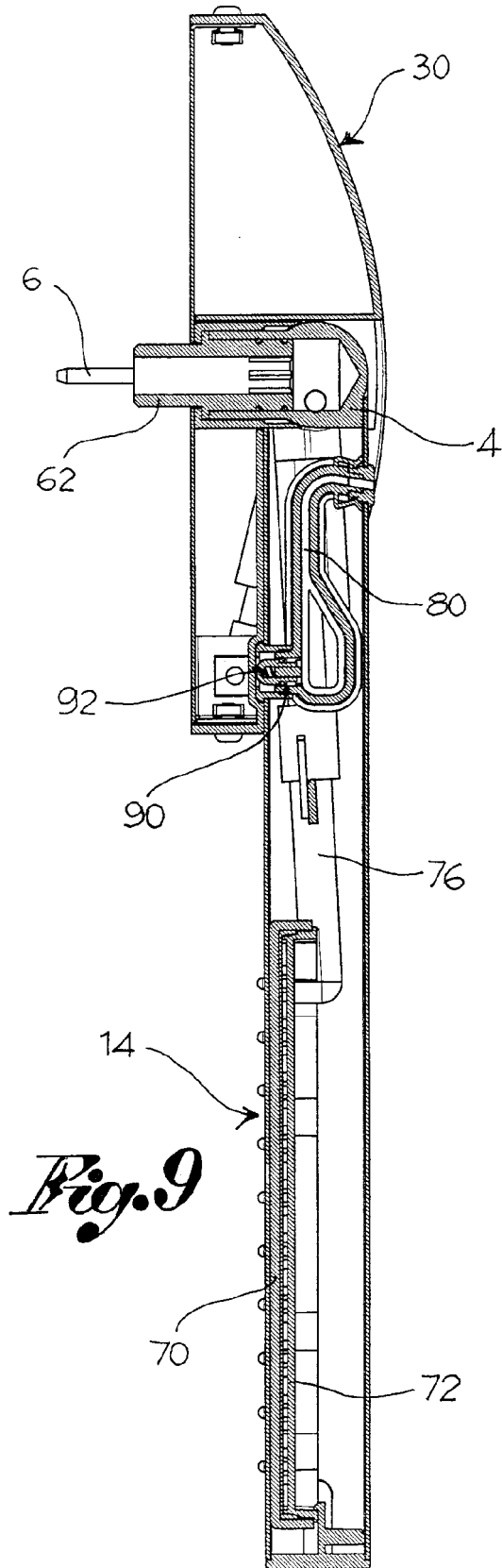

Fig. 8



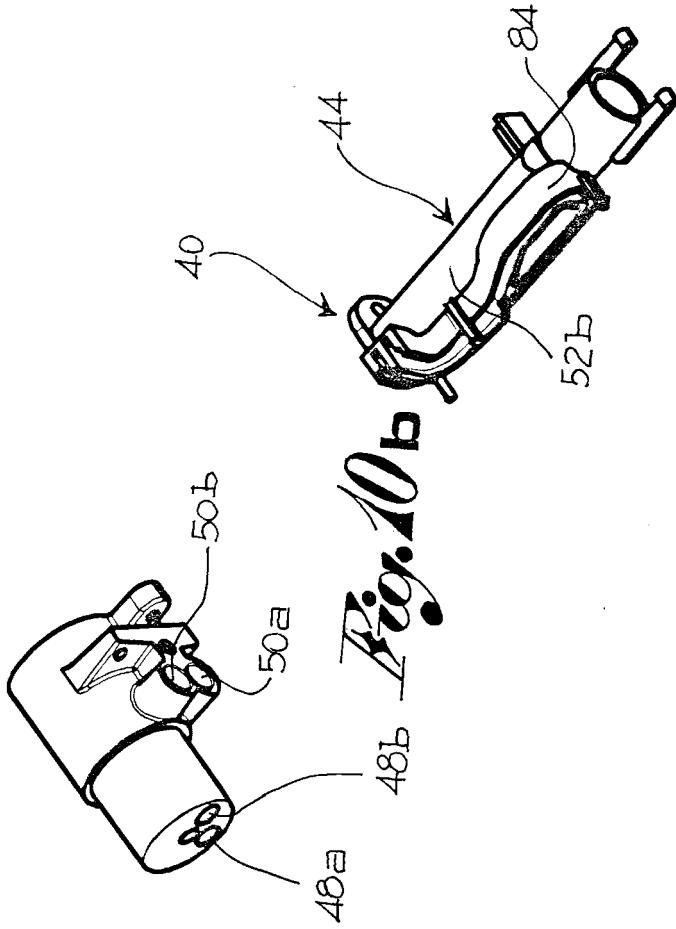

Fig. 10 b

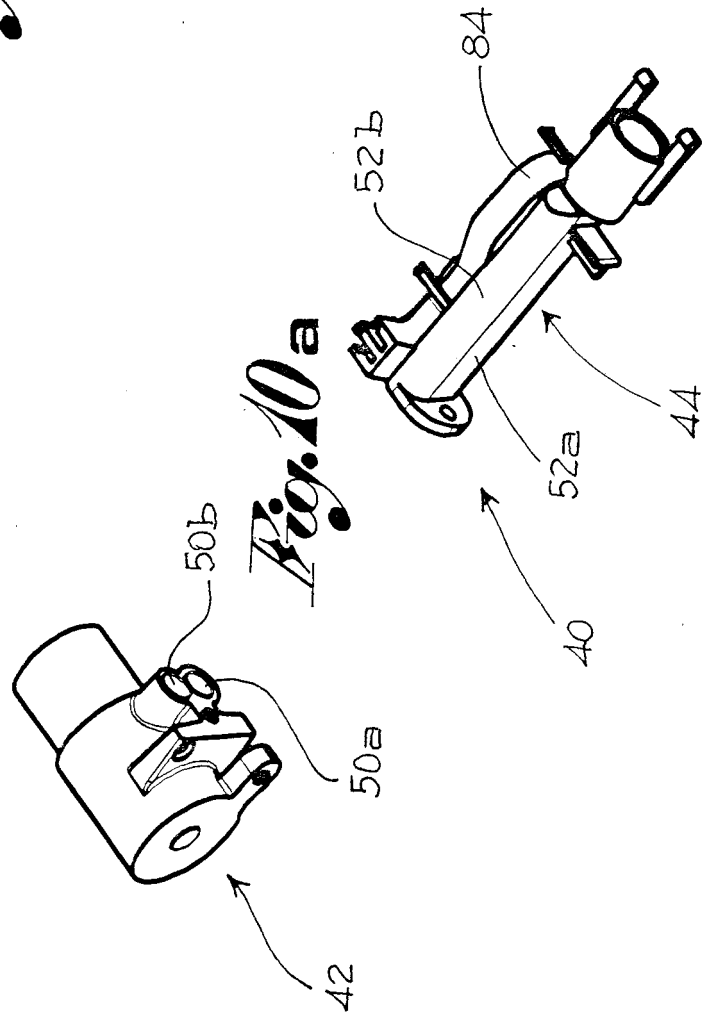
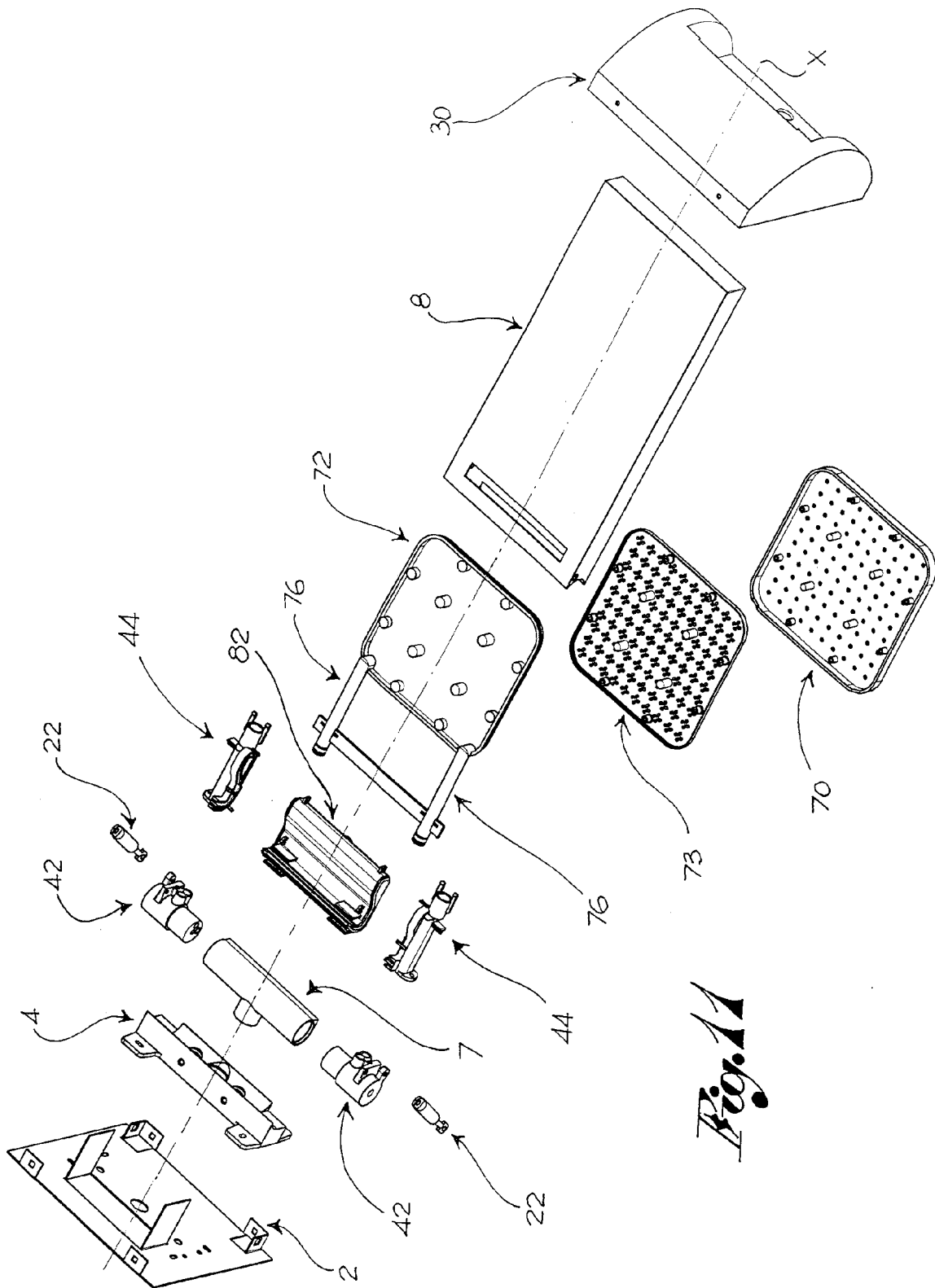

Fig. 10 a



Pro. 11

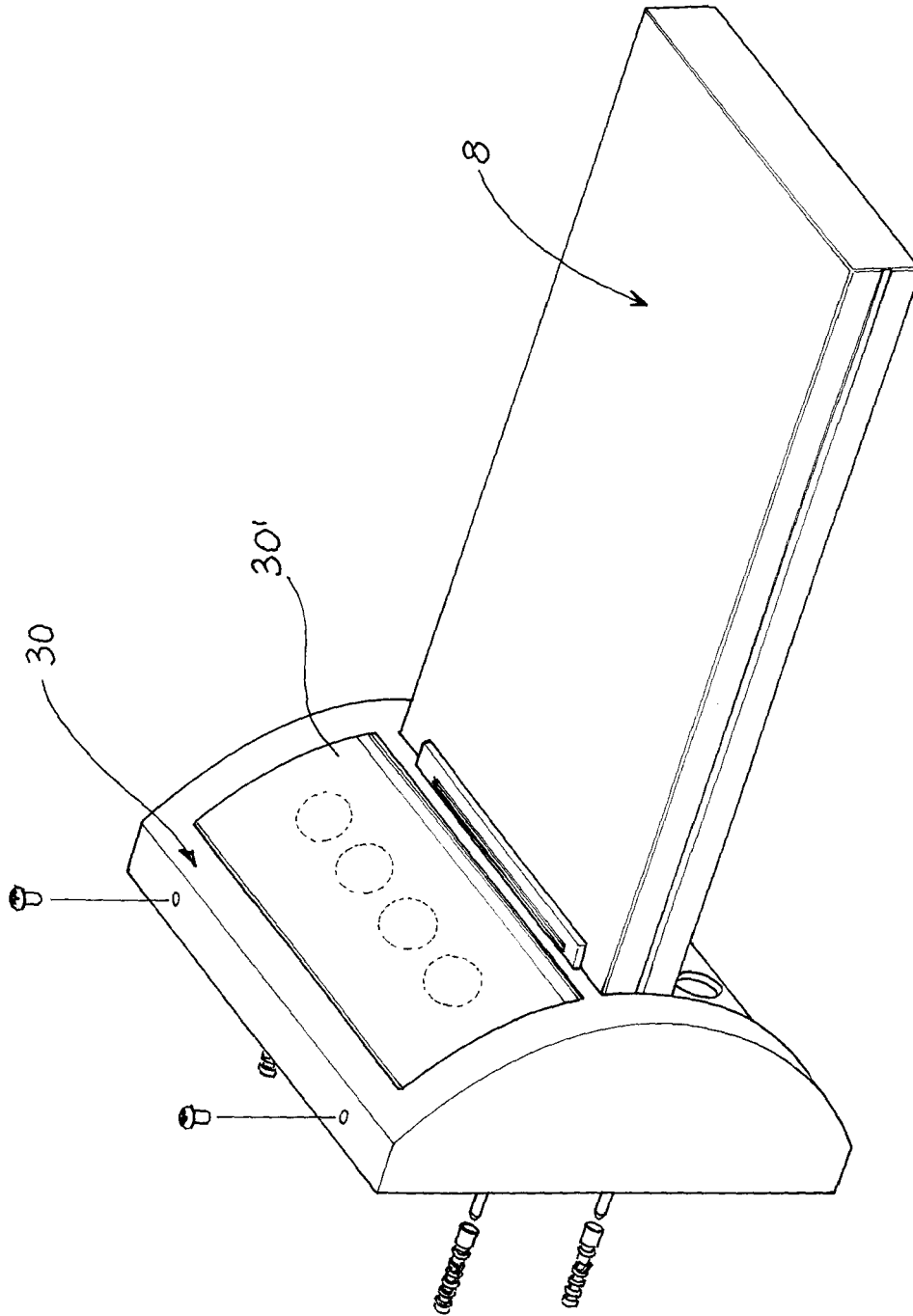

Fig. 12 a

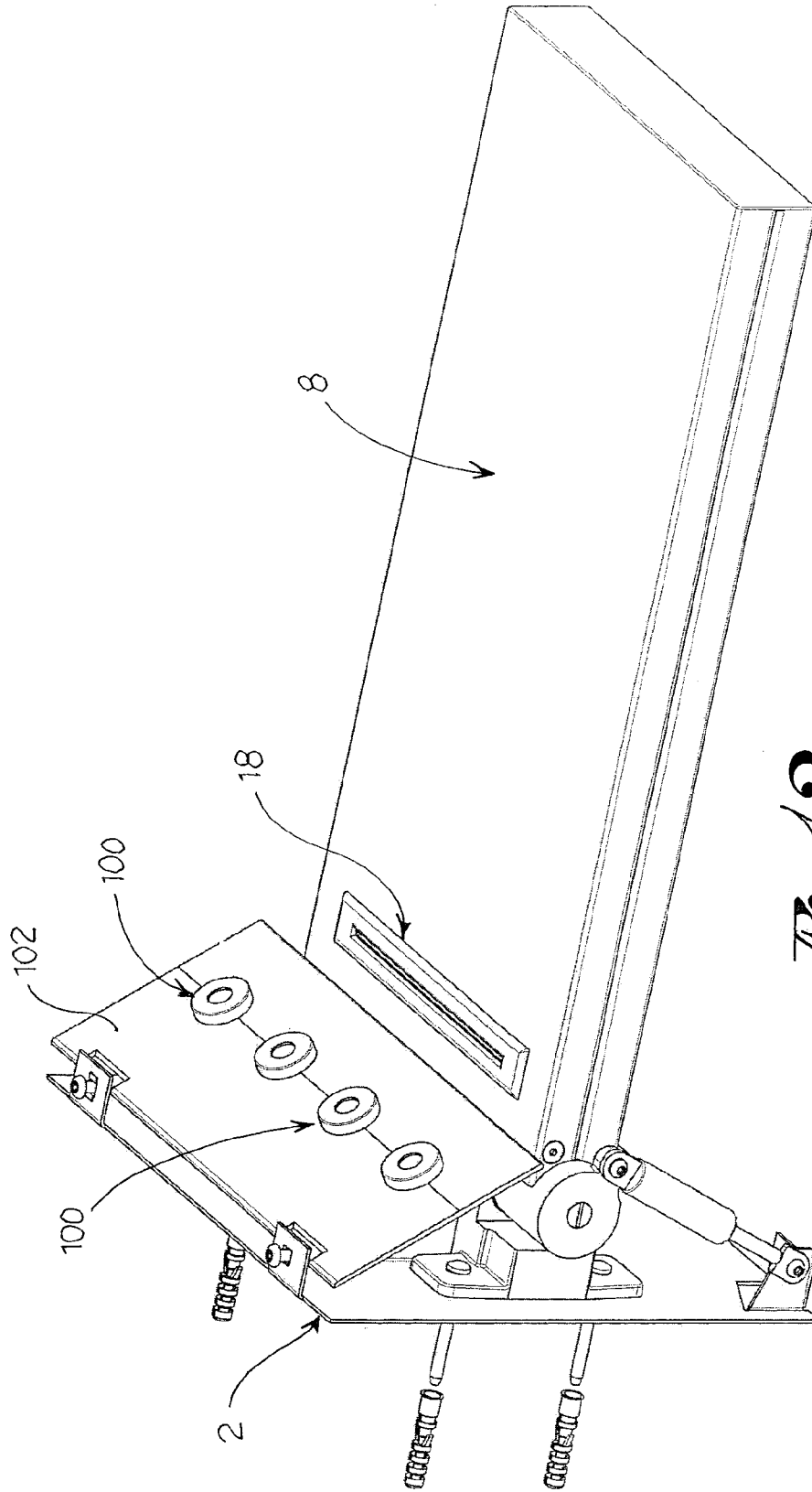

Fig. 12b

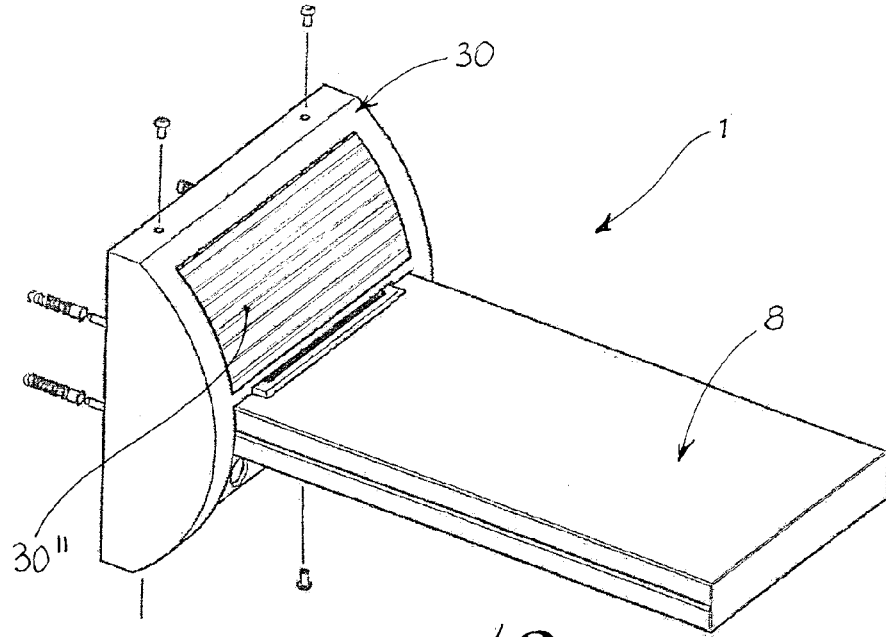

Fig. 13

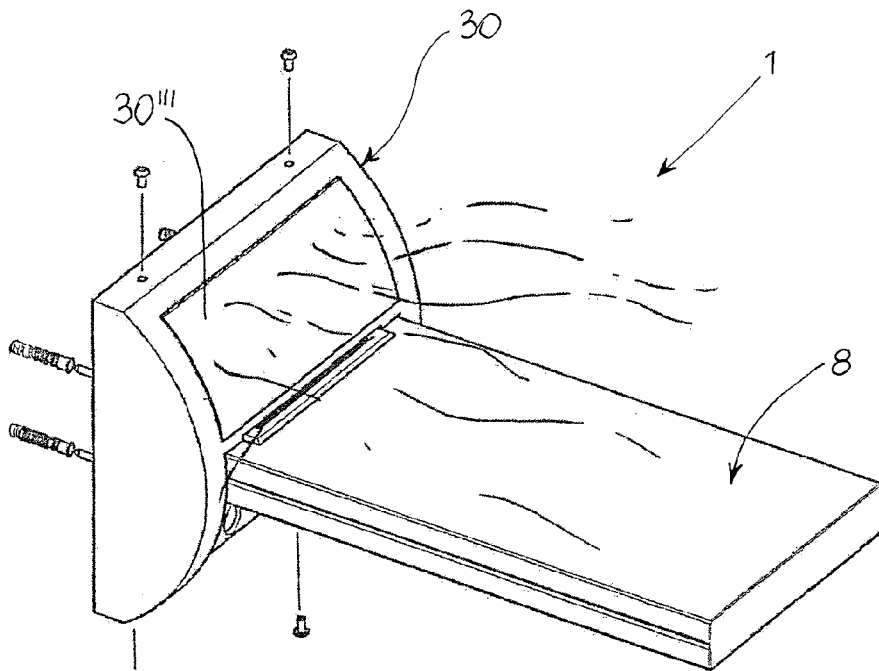

Fig. 14



EUROPEAN SEARCH REPORT

Application Number
EP 08 17 1646

DOCUMENTS CONSIDERED TO BE RELEVANT			
Category	Citation of document with indication, where appropriate, of relevant passages	Relevant to claim	CLASSIFICATION OF THE APPLICATION (IPC)
X	WO 2007/116274 A (PACKCT S R L [IT]; RIGHINI GIUSEPPE [IT]) 18 October 2007 (2007-10-18) * page 4, line 26 - page 5, line 7 * * page 6, lines 21-28 * * page 10, line 6 - page 11, line 29; figures 16-21 * * figures 1-15 * -----	1-5,10, 12-18	INV. B05B1/18 B05B1/16
X	WO 2007/025625 A (HANSA METALLWERKE AG [DE]; GALLO DINA [DE]) 8 March 2007 (2007-03-08) * page 4, line 35 - page 9, line 6; figures *	1-6,10, 13-18	
E	WO 2009/022112 A (KOHLER MIRA LTD; PEEL KEVIN TAYLOR [GB]; BARNARD JENNIFER ELLEN [GB];) 19 February 2009 (2009-02-19) * page 3, line 15 - page 4, line 15 * * page 6, line 7 - page 7, line 11 * * page 12, line 5 - page 13, line 21; figure 2 * * page 13, line 23 - page 14, line 11; figures 3-16 * * page 21, line 11 - page 22, line 13; figures 17,18 * * page 24, line 20 - page 26, line 20; figures 21-28 * * page 34, line 17 - page 36, line 18; figures 35-37 * -----	1-6,10, 12-18	TECHNICAL FIELDS SEARCHED (IPC) B05B E03C A47K B01B
A	JP 03 110228 A (TAKAGI KOGYO KK) 10 May 1991 (1991-05-10) * abstract; figures * -----	1	
The present search report has been drawn up for all claims			
Place of search Munich		Date of completion of the search 4 May 2009	Examiner Endrizzi, Silvio
CATEGORY OF CITED DOCUMENTS X : particularly relevant if taken alone Y : particularly relevant if combined with another document of the same category A : technological background O : non-written disclosure P : intermediate document		T : theory or principle underlying the invention E : earlier patent document, but published on, or after the filing date D : document cited in the application L : document cited for other reasons & : member of the same patent family, corresponding document	

1
EPO FORM 1503 03.82 (P/04C01)

**ANNEX TO THE EUROPEAN SEARCH REPORT
ON EUROPEAN PATENT APPLICATION NO.**

EP 08 17 1646

This annex lists the patent family members relating to the patent documents cited in the above-mentioned European search report. The members are as contained in the European Patent Office EDP file on The European Patent Office is in no way liable for these particulars which are merely given for the purpose of information.

04-05-2009

Patent document cited in search report	Publication date	Patent family member(s)	Publication date
WO 2007116274 A	18-10-2007	NONE	

WO 2007025625 A	08-03-2007	CN 101232947 A	30-07-2008
		DE 102005041143 B3	15-02-2007
		EP 1928609 A1	11-06-2008
		US 2008203197 A1	28-08-2008

WO 2009022112 A	19-02-2009	NONE	

JP 3110228 A	10-05-1991	JP 1797054 C	28-10-1993
		JP 5002778 B	13-01-1993

REFERENCES CITED IN THE DESCRIPTION

This list of references cited by the applicant is for the reader's convenience only. It does not form part of the European patent document. Even though great care has been taken in compiling the references, errors or omissions cannot be excluded and the EPO disclaims all liability in this regard.

Patent documents cited in the description

- EP 1647333 A1 [0004]