

(12) **UK Patent Application** (19) **GB** (11) **2475694** (13) **A**

(43) Date of A Publication

**01.06.2011**

(21) Application No: **0920681.4**  
(22) Date of Filing: **25.11.2009**

(51) INT CL:  
**F03D 7/02** (2006.01) **F03D 1/06** (2006.01)

(56) Documents Cited:  
**WO 2009/061478 A** **FR 002826066 A**  
**US 2716460 A**

(71) Applicant(s):  
**Vestas Wind Systems A/S**  
**(Incorporated in Denmark)**  
**Alsvej 21, 8940 Randers SV, Denmark**

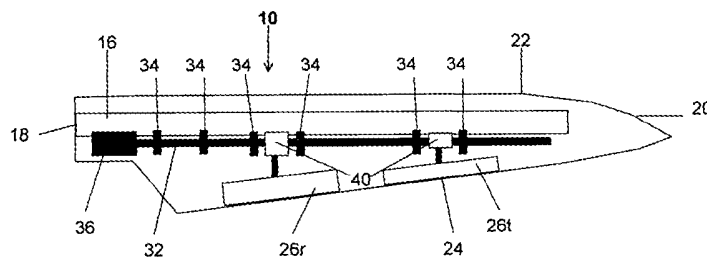
(58) Field of Search:  
INT CL **B64C, F03D**  
Other: **WPI, EPODOC**

(72) Inventor(s):  
**Carsten Hein Westergaard**

(74) Agent and/or Address for Service:  
**Reddie & Grose**  
**16 Theobalds Road, LONDON, WC1X 8PL,**  
**United Kingdom**

(54) Title of the Invention: **Flap control for wind turbine blades**  
Abstract Title: **Flap control for wind turbine blades**

(57) A wind turbine blade 20 has one or more trailing edge flaps 26r,t, slots, slats or other control surfaces and a flap actuator mechanism comprises a shaft 32 extending along at least partial blade length and driven by a motor 26 toward the blade root. The flaps connect to the shaft through a linkage so that shaft rotation pivots the flap about a hinge. The linkage may be rigid or non-rigid e.g. a single wire or rod coupled to the shaft through a roller or crank respectively and acting against an e.g. foam wedge flap failsafe extension spring bias on a surface hinged flap or a pair of oppositely acting wires or rods moving a midline hinged flap. The shaft actuator may provide slow, low frequency flap actuation e.g. 0.2 Hz but fast, high frequency individual actuation may be provided by a piezo electric stack acting on a second, L-shaped, crank between the crank and linkage or a geared roller motor mounted between the shaft and roller.



**Figure 2**

**GB 2475694 A**

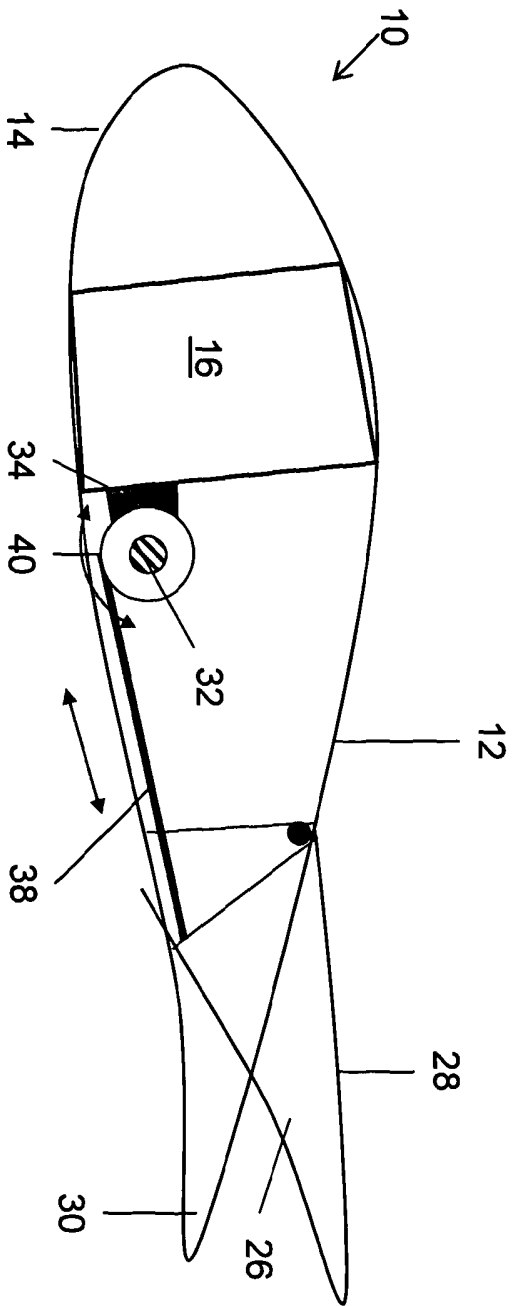
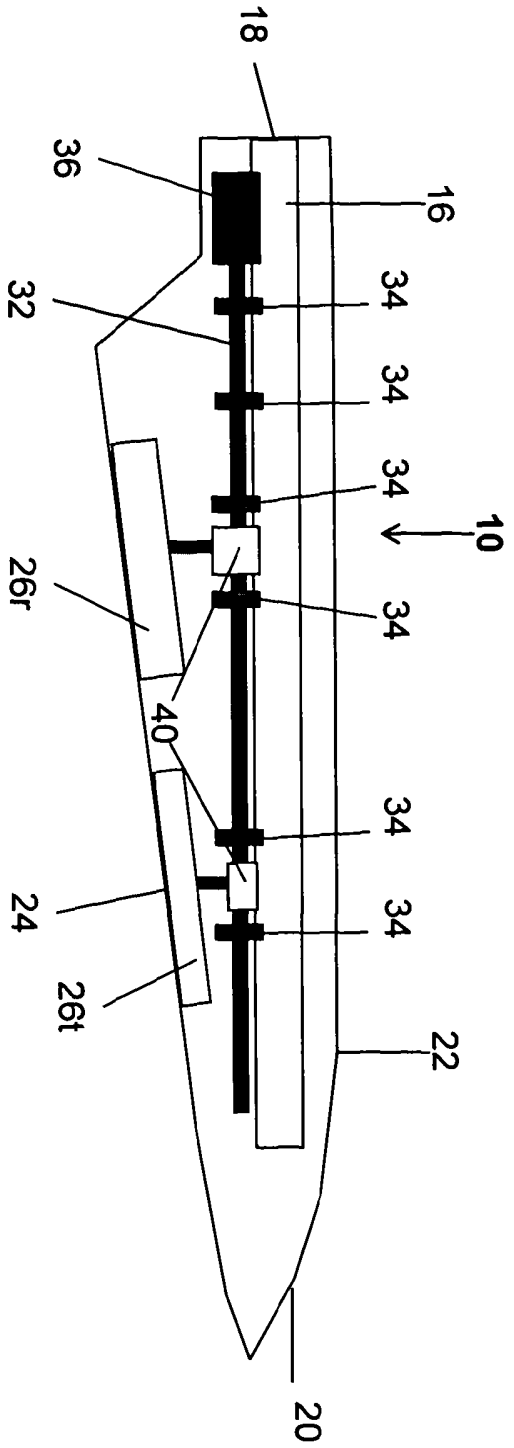


Figure 1





**Figure 2**



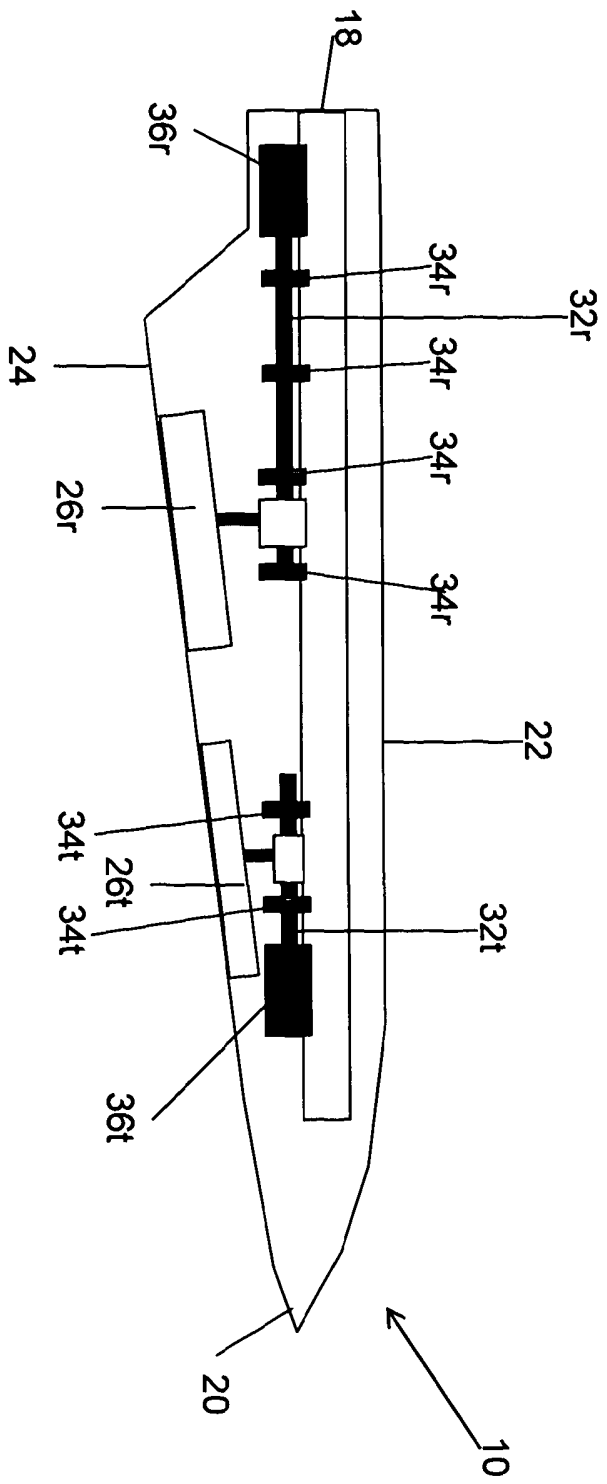


Figure 3

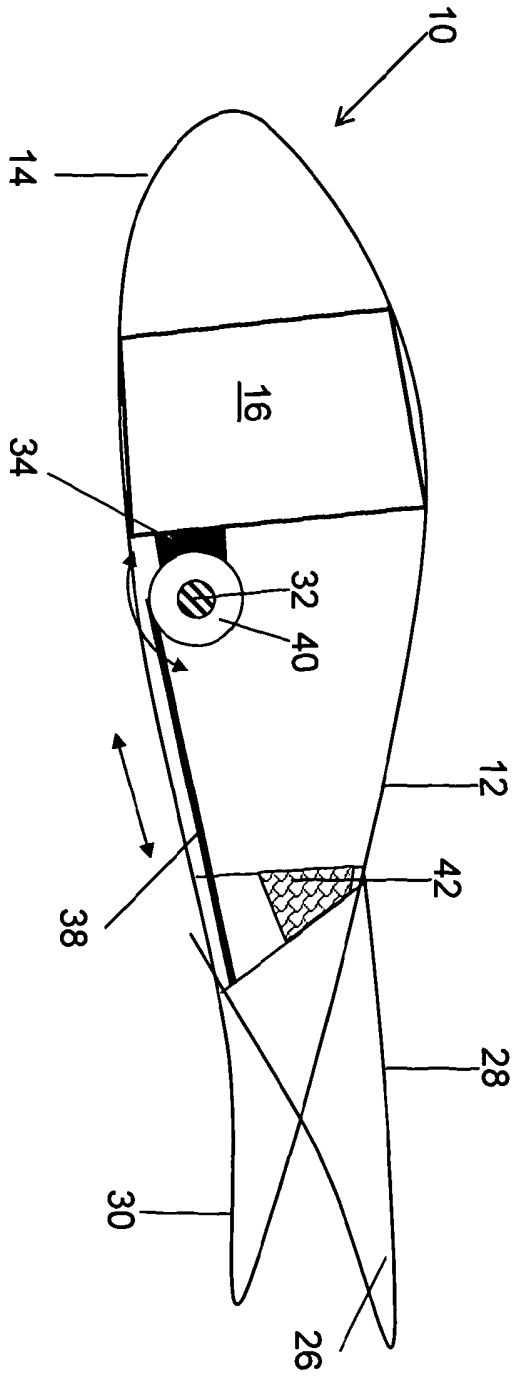


Figure 4

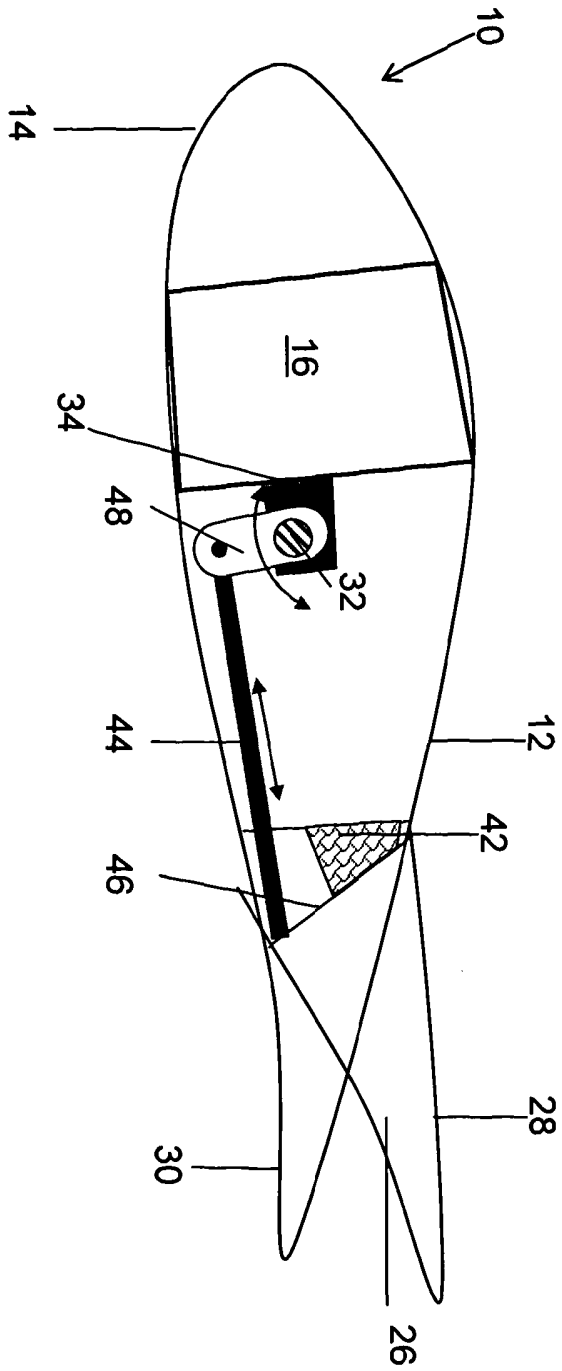


Figure 5

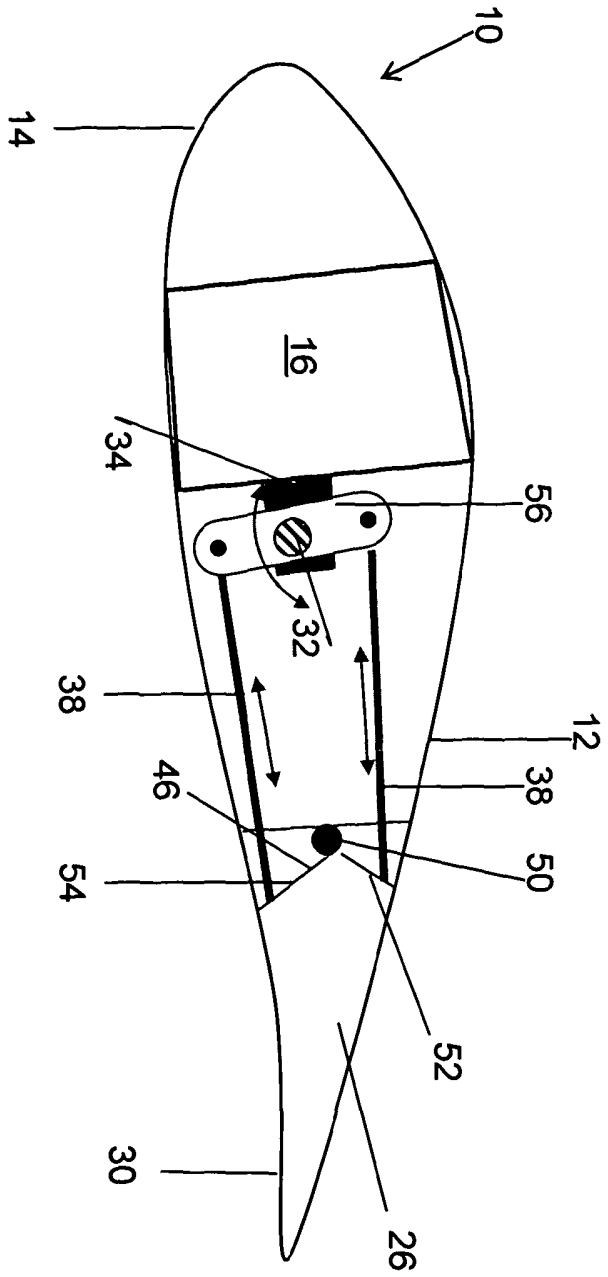
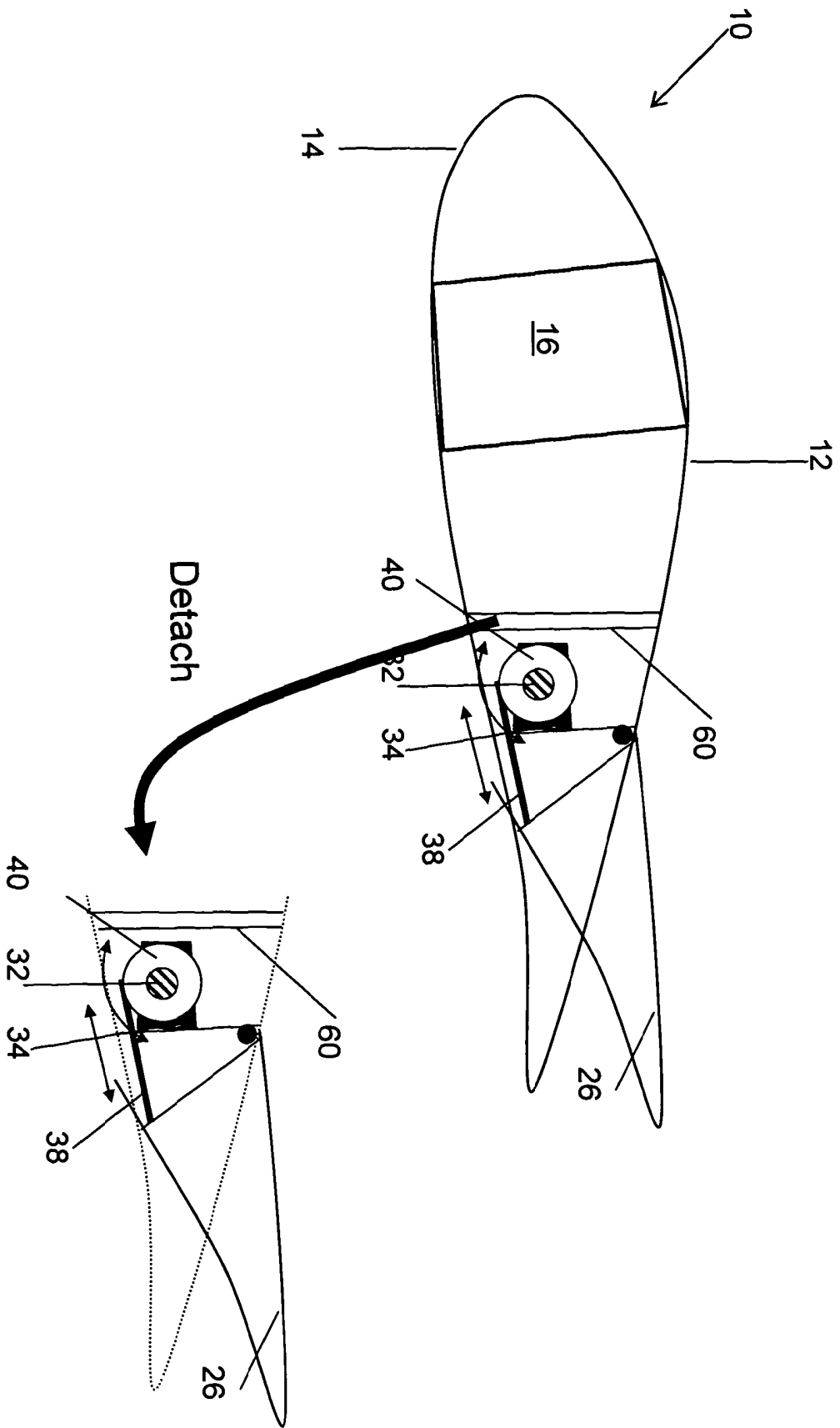
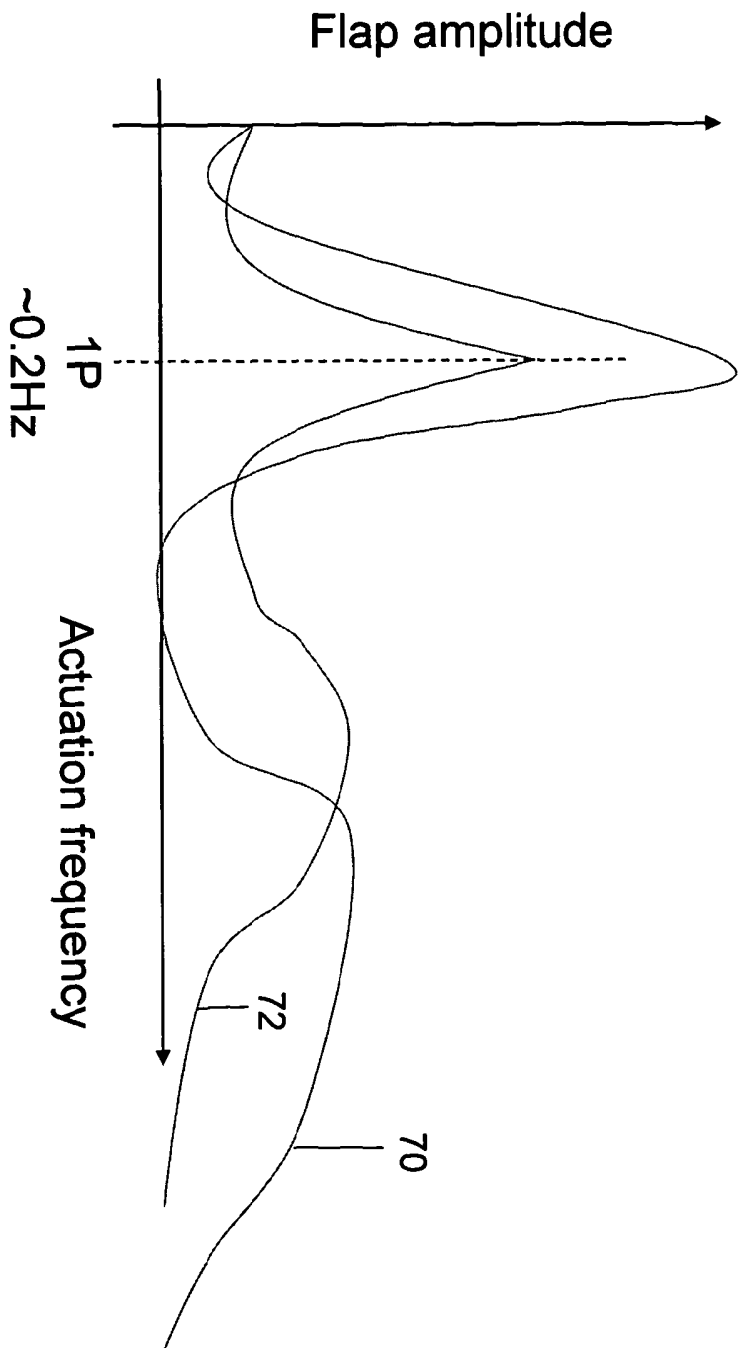


Figure 6

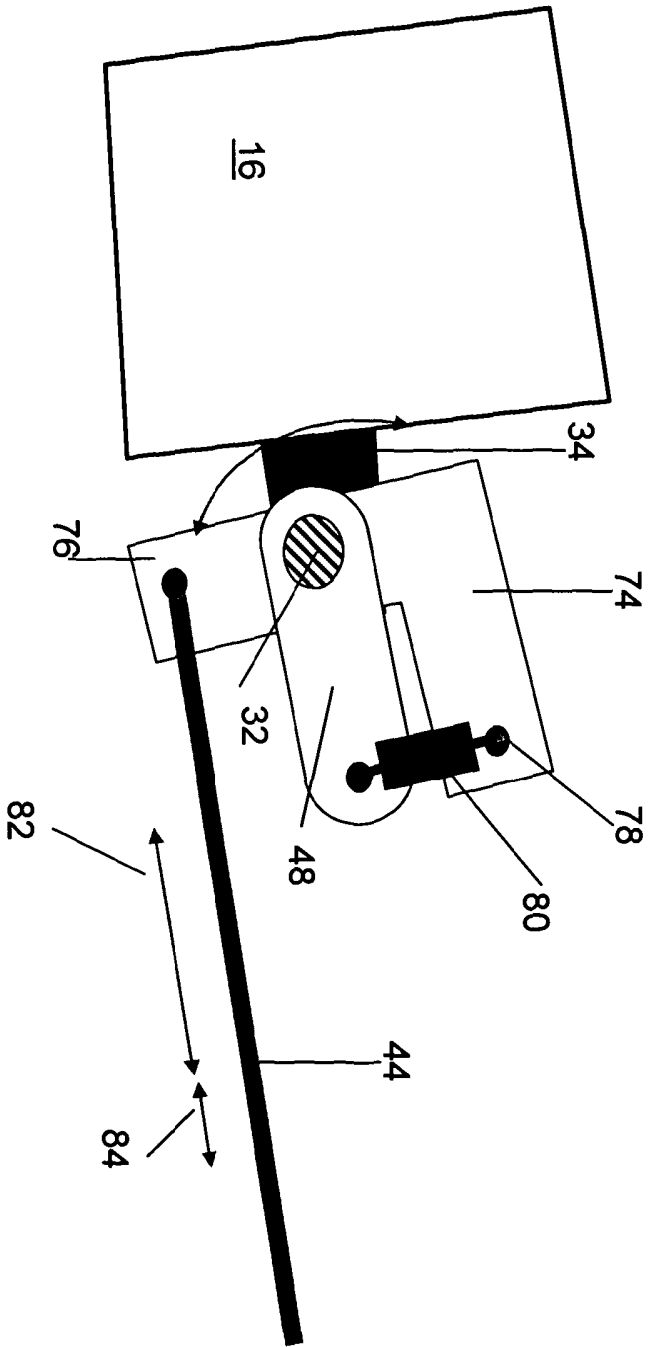
Figure 7





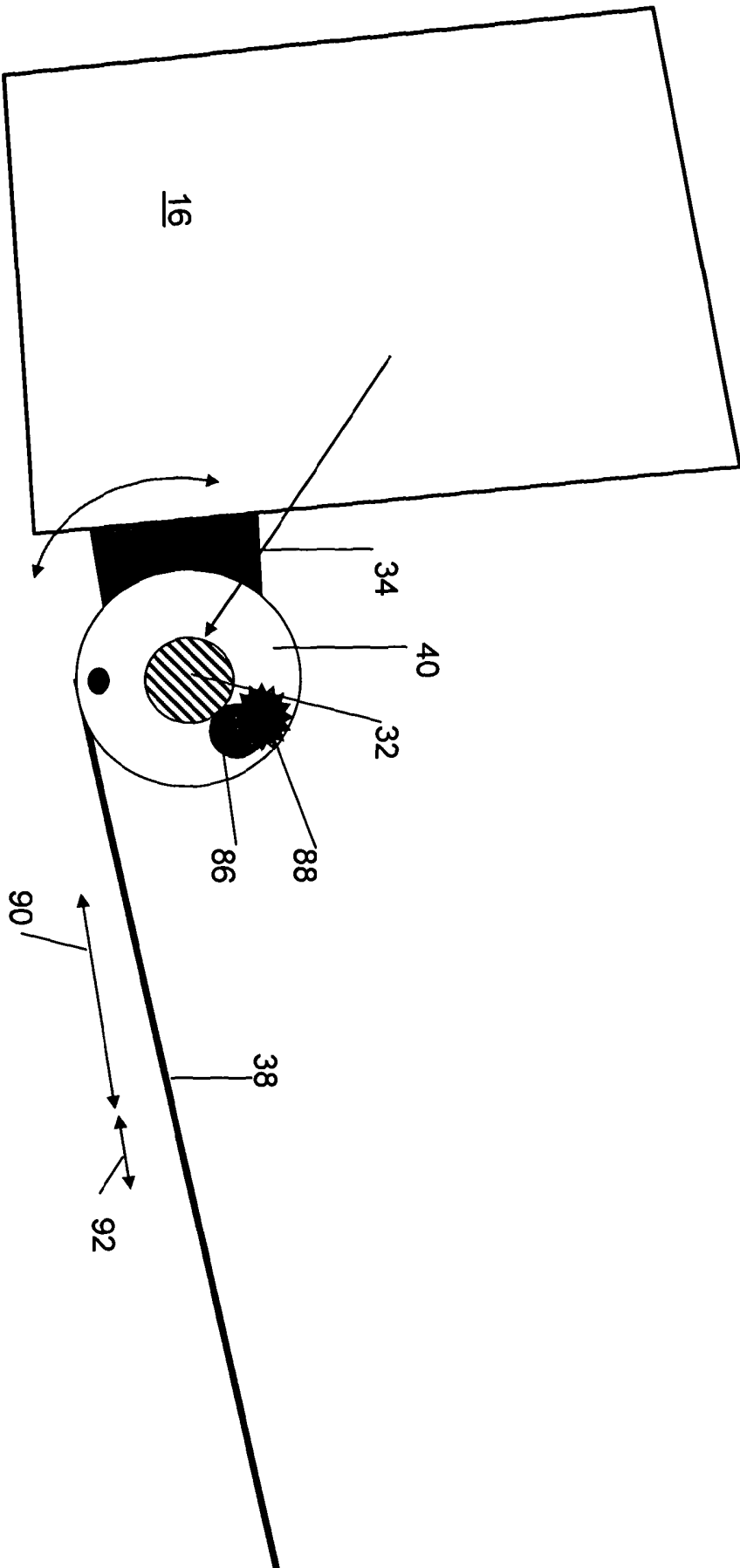


**Figure 8**



**Figure 9**

Figure 10



## FLAP CONTROL FOR WIND TURBINE BLADES

This invention relates to wind turbines, and in particular, to the control of flaps on wind turbine blades.

It is known to incorporate control surfaces into wind turbine blades, and a number of proposals have been made for actuating those control surfaces in response to various conditions.

US-A-2003/0123973 (Murakami) discloses a rotor for a wind turbine, the blades of which have extendible auxiliary blades at the blade tips, together with a plurality of extendible vanes on the leading and trailing blade edges. The leading and trailing edge vanes are controlled by hydraulic or electric actuators arranged along the length of the blade.

DE-A-2922885 (Rath) discloses a trailing edge flap arrangement for a wind turbine blade in which the flap is actuated either by hydraulic cylinders or by a connecting rod actuated by an electric motor. The flaps are at the blade tips and the actuators are arranged proximate the flaps.

These actuating arrangements are unsatisfactory as they require a large number of moving parts to be arranged within the wind turbine blade away from the nacelle. Wind turbines are often located in remote and inaccessible locations, for example, offshore, and it is desirable that maintenance is as limited and as straightforward as possible. The arrangements of US 2003/0123973 and DE-A-2922885 do not meet with these requirements. In each case, complex actuators are arranged along the blade at positions remote from blade access points at the root of the blade. This makes access difficult and time consuming and may even require removal of the blade which is impractical. Wind turbine blades may be over 40m in length and taper towards the tip. It is highly undesirable to have to access components in the interior of the blade towards the tip.

The invention aims to address the disadvantages of the prior art discussed above.

According to the invention, there is provided a wind turbine blade comprising at least one control flap on an edge of the blade and an actuation mechanism for movement of the flap, the actuation mechanism comprising an actuator shaft extending along at

least a portion of the length of the blade, an actuator coupled to the shaft to rotate the shaft, the actuator being arranged towards the root end of the blade, and a linkage coupled between the flap and the actuator shaft, whereby rotary movement of the shaft moves the flap.

Embodiments of the invention have the advantage that the actuator, which may be an electric, an hydraulic motor or similar, is arranged towards the root of the blade where it is easily accessible and may be serviced as part of a scheduled maintenance visit. Moreover, the actuation mechanism may be very simple reducing the need for maintenance and increasing reliability.

Preferably, the flap is pivotable about a hinge line wherein rotary movement of the shaft causes the linkage to pivot the flap about the hinge line.

In a preferred embodiment the linkage is a control wire. The control wire may be coupled to the actuator shaft through a roller fixed to the shaft for rotation therewith. A plurality of rollers may be arranged on the shaft, each receiving a control wire for a flap. This has the advantage that the diameter of each roller may be chosen so that rotation of the shaft causes the correct amount of movement of the flap.

In another preferred embodiment, the linkage may be a rigid rod which may be attached to the rotatable shaft through a crank arm mounted on the shaft for rotation therewith.

Preferably, a spring is arranged between the flap and the wind turbine blade whereby the flap is biased towards an extended position. This has the advantage that the flap is biased towards a failsafe position.

Preferably, the blade comprises a plurality of flaps, for example, along the trailing edge of the blade, wherein each flap is pivotable by rotation of the shaft through a respective linkage.

Preferably, the linkage comprises a first linkage and a second linkage and the flap is pivotable about a mid-point, wherein the first linkage is attached to the flap at a point above the midpoint and the second linkage is attached to the flap at a point below the midpoint, and wherein the first and second linkages are coupled to the shaft through a double arm crank fixed to the shaft for rotation therewith.

This arrangement is advantageous as it enables the flap to be controlled when it is pivoted about a hinge line at the mid-point of the flap enabling the flap to move towards both the suction and pressure sides of the blade.

Preferably, the actuator shaft extends substantially along a structural member of the blade such as a spar or beam. Alternatively, the actuator mechanism and the shaft may be formed as a unit detachable from the blade. This arrangement has the advantage that the whole actuator mechanism may be detached from the blade so facilitating maintenance.

Preferably, the actuator mechanism comprises an offset actuation mechanism for imparting movement to the linkage in addition to movement due to rotation of the shaft. The offset mechanism has the advantage of imparting a high frequency movement to one or more flaps in addition to a lower frequency movement imparted by rotation of the shaft.

The offset mechanism may comprise an L-shaped crank mounted for rotation about the shaft and to which the rigid rod linkage is attached, wherein the linkage comprises a rigid rod coupled at one end thereof to a first end of an L-shaped crank mounted for rotation about the shaft, the L-shaped crank being coupled to a crank arm mounted on the shaft for rotation therewith through a piezo-electric stack, whereby excitation of the piezo-electric stack moves the L-shaped crank with respect to the shaft to provide an offset movement to the flap.

Alternatively, where the linkage is a control wire, the offset mechanism may comprise a control wire coupled to the shaft through a roller, and the offset movement mechanism comprises a motor and gear mechanism for rotating the roller with respect to the shaft.

The invention also resides in a wind turbine having a plurality of blades each having an actuation mechanism as described above.

Embodiments of the invention will now be described by way of example only, and with reference to the accompanying drawings, in which:

Figure 1 is a cross-section through a wind turbine blade having a trailing edge flap and embodying the invention;

Figure 2 is a schematic plan of a wind turbine blade having a pair of trailing edge flaps and embodying the invention;

Figure 3 is a similar view to Figure 2 showing an alternative flap control arrangement;

Figure 4 shows an enhancement to the embodiment of Figure 1;

Figure 5 shows an alternative arrangement to the embodiment of Figure 4;

Figure 6 shows a further embodiment of the invention;

Figure 7 shows a further embodiment of the invention in which the trailing edge flap is mounted as a detachable unit;

Figure 8 is a graph of actuation frequency against flap amplitude showing optimal flap performance;

Figure 9 shows a further embodiment of the invention permitting fast offset movement of the flap; and

Figure 10 is an alternative arrangement to that of Figure 9.

The following description relates to control of one or more trailing edge flaps on a wind turbine blade. The term "flap" refers to a movable surface of the wind turbine blade which will modify the aerodynamic profile of the wind turbine blade. However, the invention is not limited to trailing edge flaps but is also applicable to the actuation of leading edge devices (typically slots or slats) and other control surfaces arranged along the blade edges as opposed to the tip only. The following description is limited to trailing edge flaps for simplicity. Moreover, the embodiments to be described are not limited to any particular number of flaps, wherever located, and may be used to actuate a single flap or two or more flaps arranged along the leading or trailing edge of a blade.

When designing a flap system for a wind turbine it is highly desirable to move the vulnerable parts, such as the actuators, from the outer parts of the blades to the roots so that they can be serviced as part of the normal service visits and accessed through the hub. Components located towards the blade tips are hard to access in situ and may require the blades to be removed.

Figure 1 shows a cross-section of a wind turbine blade. The present invention is applicable to any wind turbine, for example a horizontal axis turbine having a rotor within three blades.

The blade 10 comprises an upper surface 12 and a lower surface 14, commonly referred to as the suction surface and the pressure surface, each made from a lightweight composite material by well known techniques. A strengthening spar 16 or beam extends along the length of the blade, as can be seen from Figures 2 and 3, from the root end 18 of the blade towards the tip end 20. The blade has a leading edge 22 and a trailing edge 24. The trailing edge has at least one moveable flap 26 arranged along a part of its length. As can be seen from Figure 1, this flap is moveable by an actuation mechanism between an extended position 28 in which the flap extends on the suction side of the blade, and a retracted position 30, in which the flap is flush with the blade. These two positions are shown in Figure 1 and the flap may adopt any intermediate position. The extent of movement of the flap is a matter of design choice and the flap may be configured to extend on the pressure side of the blade if desired.

As shown in Figure 1, the flap is hinged for rotation about a hinge line that forms part of the suction surface of the blade. The hinge may be the actual material of the upper shell of the blade, suitably strengthened if necessary, or may be a mechanical hinge arranged, for example, under the surface. As will become clear from further embodiments described below, the hinge position may change.

In the embodiment of Figures 1 to 3, the flap is spring biased towards the extended position shown on the suction side. Thus, the flap will adopt the extended position if no force is applied against the bias of the spring. The fail-safe position is therefore in the extended or deployed position on the suction side of the blade as this provides the lowest possible lift coefficient. This is desirable, for example, in the parked condition where a loss of power may cause the flaps to be un-deployable. In these conditions it is desirable that the loading on the blade is as low as possible.

As can best be seen from Figure 2, the actuation mechanism includes an actuator shaft 32 arranged to extend along at least a portion of the length of the blade. In this embodiment, the shaft is a torsion shaft and is arranged alongside the beam, generally following the neutral line of the blade. As will become clear from later



embodiments, this is desirable but not essential. The actuator shaft 32 is mounted for rotation with respect to a plurality of supports 34 which may be roller bearings or bushings, for example, and which are fixed to the beam at points along its length. At the root end of the blade, the free end of the shaft is attached to an actuator 36 which is arranged towards the root end of the blade and which serves to actuate the shaft. It is presently considered that the shaft should be arranged close to the pressure side 14 of the blade to maintain the optimum angle between the wire and the perpendicular to the hinge line to give maximum torque on the hinge. However, this may not be practical in some blade designs which have a high degree of curvature along their length. In such blades, the shaft may be mounted closer to the suction side or the wire 38 may be permitted to penetrate the pressure side 14 of the blade shell. It is generally considered better for the suction side to be smooth and so the hinge is located on the suction side. By placing the rod or wire at the pressure side the stress in the system is reduced and a greater linear actuation is ensured as the angle between the arm 48 and the rod 44 can be close to 90 degrees.

A control linkage comprising a control wire 38 is attached to the shaft at one end and to the flap 26 at its other end. As shown in Figure 1, the wire is attached to the rear wall of the flap towards the flap edge opposite the hinged edge. Thus, in Figure 1, where the hinge is on the suction side of the flap, the control wire is attached to a back wall of the flap near the pressure side of the flap. Although the control wire may be attached directly to the shaft, it is preferred, as shown in Figure 1, that it is attached to a roller or drum 40 which is mounted on the shaft for rotation of the shaft. The diameter of the roller will determine the amount of movement of the control wire for a given degree of movement of the shaft. Thus, by selecting different roller diameters, differing amounts of movement may be obtained for a plurality of control wires. The amount of movement required will depend on the flap size and the profile size at that region of the blade. As shown in Figure 2 the roller associated with the tipwards flap 26t has a smaller diameter than the roller associated with the hubwards flap 26r as the amount of movement required is lower.

The actuator may, for example, be a hydraulic or electric motor.

Figure 3 shows an alternative arrangement in which the shaft is split into first and second shafts each driven by a respective motor and each actuating a respective one of the two flaps. In Figure 3, the motors, shafts, support, rollers and wire have

the same references as in Figure 2 with the addition of the suffix 'r' or 't' to denote whether they are the tip (t) or root (r) and assembly. Further shafts and motors could be added to control additional flaps (not shown). From a maintenance perspective, this arrangement is less preferred than that of Figure 2 as the location of the motor for the tipwards flap is inconvenient and inaccessible for servicing. The embodiment of Figure 2 has the advantage that the single motor is easily accessible at the root end of the block making access for service and maintenance straightforward.

In order to deploy the flaps, the actuator(s) may only need to rotate the torsion shaft through a portion of a rotation, for example, 1/3 of a turn.

The actuator shaft 32 is preferably torsionally stiff but otherwise non-stiff enabling it to follow blade movement over the lifetime of the blade which is intended to be 20 years. The shaft is preferably made from a composite material.

Thus, in the embodiment described, rotary movement of the shaft by the actuator causes movement of the flap. In particular, shaft rotation causes the flap to pivot about the hinge line.

As mentioned previously, in the embodiment of Figures 1 to 3, the flap or flaps are biased towards the extended position. It will now be appreciated that this is necessary for the control wire arrangement to work. Figure 4 shows one possible spring arrangement in which a block of shaped compressible rubber 42 or other suitable material is arranged beneath the hinge line between a rear wall of the blade and the rear wall of the flap. The block may be a rubber foam element. The compressed rubber 42 acts to bias the flap towards the extended position. Any other suitable spring could be used, such as a leaf spring or a compression spring.

Figure 5 shows an alternative arrangement for the control linkage which connects the shaft to the flap. In this embodiment, the flap is still biased outwards by a spring, but this is no longer essential as the link between the shaft and the flap is rigid. A spring is still preferred to eliminate flutter and to ensure a low lift coefficient fail safe position. A push rod 44 is connected at the bottom of the rear wall 46 of the flap at essentially the same location as the control wire of Figure 1. However, as the control linkage is rigid, the roller 40 is replaced by a crank arm 48 which is mounted at one end for rotation on the shaft and at another end is coupled to the rigid linkage 44 such that

rotation of the shaft translates to reciprocal movement of the push rod or rigid linkage.

In the preceding embodiments, the flaps have been hinged about a hinge line on the suction surface of the blade and flap. Figure 6 shows an alternative arrangement in which the hinge line 50 is along a midpoint of the height of the flap such that the flap is free to move towards both the pressure and suction sides of the blades. In view of this movement, the rear wall 46 of the flap 26 has an upper section 52 that slopes from the hinge line away from the blade towards the trailing edge and a similar lower section 54. The flap is actuated by a double crank arm 56 which is coupled at its centre to the shaft for rotation with the shaft 32. Each of the ends of the double crank arm 56 are connected to a control linkage, here shown as a control wire 38, the other end of which is connected to the upper and lower rear wall sections of the flap respectively. Thus, rotation of the actuator shaft in a clockwise direction will cause the flap to move towards the pressure side, whereas counter clockwise rotation of the shaft will cause the flap to move towards the suction side. As the control members are non-rigid wires, a spring (not shown) such as the shaped compressed rubber foam block of previous embodiments is required to bias at least one of the two flap connections. The spring may be arranged between the rear wall section of the flap or between the blade rear wall and the upper rear wall section of the flap, or between both rear wall sections.

Alternatively, the coupling wires of Figure 6 could be replaced by rigid linkages as used in Figure 5 removing the need for biasing springs although these may be desirable.

This embodiment has the advantage of reduced slack in the system, but the torsion arm, being the distance between the pull point on the flap and the hinge is halved.

In the embodiments of Figures 1 to 6, the actuator shaft is arranged along the length of the spar or beam 16, essentially along the neutral line of the blade as this position is the least likely to give rise to fatigue problems caused by constant rotation of the blade over years of operation. While this is desirable, it is also highly desirable to be able to gain access to moving parts of the blade easily for repair and maintenance. In the embodiment of Figure 7, the shaft is located in a separate detachable unit or section 60 which includes the flap 26 or flaps. Where the blade has multiple flaps, a

separate shaft arrangement may be provided for each flap such that each flap forms a separate detachable section to reduce the size of the detachable sections. In the Figure, the arrangement shown is that of the control wire and roller described with respect to Figure 1. However, any of the other arrangements described above could be used. In the arrangement shown in Figure 7, the shaft supports 34 are mounted on a wall 62 of the detachable section that abuts the blade when the section is in place. The actuators 36 which drive the flap actuating shaft or shafts may be controlled by a separate controller, or more preferably by the main wind turbine controller which controls various turbine parameters such as rotor speed and blade pitch angle. A main control parameter for the flaps is to reduce loading on the blade and the flap system as it rotates to an optimal condition. Figure 8 shows a plot of actuation frequency against flap amplitude for two different load cases identified as 70 and 72. The actuation frequency 1P corresponding to one flap movement per rotor rotation is predominant and is caused by issues such as wind gradient, yaw error and other variables which depend on blade position. It can be seen from the figure that a very substantial part of the optimal control of the flap system can be achieved by adjusting the flaps one per revolution of the blade. This frequency, which is roughly 0.2Hz makes the arrangements of the embodiments described extremely practical and can easily provide the desired frequency of movement of the flaps. However, although this arrangement may achieve the majority of the benefit available, for example, up to 70% of a maximum achievable, there are still large and significant gains which can be obtained by actuating the flaps much more frequently, for example, 10 times faster. The arrangements of Figures 1 to 7 are not necessarily optimised for a frequency of actuation that is that high, while maintaining 20 years service free life time. Moreover, at faster actuation speeds, it may be desirable to actuate flaps individually and it may also be easier to actuate flaps individually in view of their large size. Figures 9 and 10 illustrate modifications of the embodiments of Figures 1 to 7 which enable faster movements of the flaps. In each of the embodiments the low frequency movement of the flaps, once per revolution, is maintained and a higher frequency offset component added.

Figure 9 is an enlarged view of the shaft and linkage arrangement shown in Figures 1 to 7. The blade shell and the flap have been removed for simplicity and ease of understanding. The shaft 32 is shown supported on beam 16 by supports 34 with crank arm 48 arranged to rotate with the shaft. An L-shaped crank 74 is arranged to

rotate freely about the shaft and is connected at one end 76 to the linkage, here shown as push rod 44 but alternatively a control wire as in earlier embodiments. The other end 78 of the L-shaped crank is coupled to the free end of the crank arm 48 by a fast actuator 80. This actuator can impart movement to the L-shaped crank relative to the crank arm 48 and may be, for example, a piezo-electric stack. Higher frequency signals may be sent to the piezo-electric stack from the turbine controller or a dedicated flap controller to excite the stack and thus move the L-shaped crank, relative to the crank arm 48 and the shaft, so imparting additional movement to the linkage 44 and through it to the flap (not shown).

In Figure 9, the leftmost straight double headed arrow 82 indicates that the majority of movement of the linkage is slow movement (once per revolution) from rotation of the shaft whereas the right hand double headed arrow 84 indicates a smaller component of addition fast movement from the offset actuator comprising the L-shaped crank and the piezo-electric stack.

Thus, this embodiment provides an offset to the movement provided by rotation of the shaft and the crank arm (or roller). It will be appreciated that separate L-shaped cranks and piezo-electric stacks may be provided for each flap and, as the stacks are controlled individually, the fast moving offset movement may be applied separately to each flap.

The arrangement of Figure 9 is preferred for a rigid control linkage and crank arm arrangement. An alternative arrangement is shown in Figure 10 which is presently preferred for the roller and wire linkage of Figure 1. In this embodiment, the roller 40 can be driven by rotation of the shaft 32 and additionally by a fast movement motor 86 that imparts movement to the roller through an offset gear 88. This gear may mesh with a splined inner surface of the roller (not shown) to impart movement. The motor 86 is fixed to the rod 32 and drives the gear 88. The gear in turn drives the roller or drum 40 to provide fast, but small movements of the wire 38.

As with the previous embodiment, the fast movement motor may be individual to each flap enabling the offset movement to be applied to each flap individually. The extent of movement provided by the shaft rotation is indicated by double headed arrow 90 and that provided by the offset motor and gear is indicated by double

headed arrow 92. The speed of actuation may be increased by using spiral splines on the shaft combined with axial movement of the shaft.

Embodiments of the invention have the advantage of providing a simple control mechanism for the flap or flaps on a wind turbine blade, for example, on the trailing edge. The use of a motor actuated shaft enables the motor to be located towards the root of the blade making inspection and maintenance easy and locates the motor relatively close to the turbine controller in the turbine nacelle which is desirable. Moreover, some embodiments of the invention enable movement to be imparted to multiple flaps through a single motor and also additional offset movements to be imparted to individual flaps to provide higher frequency movement.

## Claims

1. A wind turbine blade comprising at least one control flap on an edge of the blade, and an actuation mechanism for controlling movement of the flap, the actuation mechanism comprising an actuator shaft extending along at least a portion of the length of the blade, an actuator coupled to the shaft to rotate the shaft, the actuator being arranged towards the root end of the blade, and a linkage coupled between the flap and the actuator shaft, whereby rotary movement of the shaft moves the flap.
2. A wind turbine blade according to claim 1, wherein the flap is pivotable about a hinge line and wherein rotary movement of the shaft causes the linkage to pivot the flap about the hinge line.
3. A wind turbine blade according to claim 1 or 2, wherein the linkage is a control wire.
4. A wind turbine blade according to claim 3, wherein the control wire is coupled to the actuator shaft through a roller fixed to the shaft for rotation therewith.
5. A wind turbine blade according to claim 1 or 2, wherein the linkage is a rigid rod.
6. A wind turbine blade according to claim 5, wherein the rigid rod is attached to the rotatable shaft through a crank arm mounted on the shaft for rotation therewith.
7. A wind turbine blade according to any preceding claim wherein the linkage comprises a first linkage and a second linkage and the flap is pivotable about a midpoint, wherein the first linkage is attached to the flap at a point above the midpoint and the second linkage is attached to the flap at a point below the midpoint, and wherein the first and second linkages are coupled to the shaft through a double arm crank fixed to the shaft for rotation therewith.
8. A wind turbine blade according to any preceding claim comprising a spring arranged between the flap and the blade, the spring biasing the flap towards an extended position.

9. A wind turbine blade according to any preceding claim, comprising a plurality of control flaps, each control flap being movable by rotation of the shaft through a respective linkage.
10. A wind turbine blade according to any preceding claim, wherein the actuator shaft extends substantially along a structural member of the blade.
11. A wind turbine blade according to any of claims 1 to 9, wherein the actuation mechanism and the flap are formed as a unit detachable from the blade.
12. A wind turbine blade according to any preceding claim, wherein the actuation mechanism comprises an offset actuation mechanism for imparting movement to the linkage in addition to movement due to rotation of the shaft.
13. A wind turbine blade according to claim 12, wherein the linkage comprises a rigid rod coupled at one end thereof to a first end of an L-shaped crank mounted for rotation about the shaft, the L-shaped crank being coupled to a crank arm mounted on the shaft for rotation therewith through a piezo-electric stack, whereby excitation of the piezo-electric stack moves the L-shaped crank with respect to the shaft to provide an offset movement to the flap.
14. A wind turbine blade according to claim 12, wherein the linkage comprises a control wire coupled to the shaft through a roller, and the offset movement mechanism comprises a motor and gear mechanism for rotating the roller with respect to the shaft.
15. A wind turbine having a rotor comprising a plurality of rotor blades according to any of claims 1 to 14.





**Application No:** GB0920681.4

**Examiner:** James Paddock

**Claims searched:** 1-15

**Date of search:** 26 February 2010

**Patents Act 1977: Search Report under Section 17**

**Documents considered to be relevant:**

Category	Relevant to claims	Identity of document and passage or figure of particular relevance
X	1,2,5,6	WO2009/061478 A FLEXSYS See Figure 6 and page 12, line 24 to page 13, line 12. Rotary actuator considered for inboard mounting and operating leading edge flap.
X	1,2,5	FR2826066 A TROMELIN See the figures and WPI abstract accession No: 2003-142562 [14]. Flap pivoted at turbine blade leading edge is deployed by motor rotation of spanwise endless screw.
X	1,2,5,6,9	US2716460 A YOUNG See the Figures. Inboard crank-rotary input to spanwise shaft moves further cranks and linkage to adjust rotary wing flaps.

**Categories:**

X	Document indicating lack of novelty or inventive step	A	Document indicating technological background and/or state of the art.
Y	Document indicating lack of inventive step if combined with one or more other documents of same category.	P	Document published on or after the declared priority date but before the filing date of this invention.
&	Member of the same patent family	E	Patent document published on or after, but with priority date earlier than, the filing date of this application.

**Field of Search:**

Search of GB, EP, WO & US patent documents classified in the following areas of the UKC<sup>X</sup> :

Worldwide search of patent documents classified in the following areas of the IPC

B64C; F03D

The following online and other databases have been used in the preparation of this search report

WPI, EPODOC

**International Classification:**

Subclass	Subgroup	Valid From
F03D	0007/02	01/01/2006
F03D	0001/06	01/01/2006