



(51) International Patent Classification:

*E05B 47/00* (2006.01)      *E05B 45/08* (2006.01)  
*E05B 45/06* (2006.01)

(21) International Application Number:

PCT/US2021/043913

(22) International Filing Date:

30 July 2021 (30.07.2021)

(25) Filing Language:

English

(26) Publication Language:

English

(30) Priority Data:

63/058,970      30 July 2020 (30.07.2020)      US

(71) Applicant: **HAVENLOCK INC.** [US/US]; 188 Front St. Suite 116-112, Franklin, Tennessee 37064-5078 (US).

(72) Inventors: **BERTELLI, Alexander Michael**; 188 Front St. Suite 116-112, Franklin, Tennessee 37064-5078 (US). **BANKS, Kenneth Clay**; 188 Front St. Suite 116-112, Franklin, Tennessee 37064-5078 (US). **KUHLMAN,**

**Fredrick Bachman**; 188 Front St. Suite 116-112, Franklin, Tennessee 37064-5078 (US).

(74) Agent: **FORD, Grant M.** et al.; 1600 Division Street, Suite 500, Nashville, Tennessee 37203 (US).

(81) Designated States (unless otherwise indicated, for every kind of national protection available): AE, AG, AL, AM, AO, AT, AU, AZ, BA, BB, BG, BH, BN, BR, BW, BY, BZ, CA, CH, CL, CN, CO, CR, CU, CZ, DE, DJ, DK, DM, DO, DZ, EC, EE, EG, ES, FI, GB, GD, GE, GH, GM, GT, HN, HR, HU, ID, IL, IN, IR, IS, IT, JO, JP, KE, KG, KH, KN, KP, KR, KW, KZ, LA, LC, LK, LR, LS, LU, LY, MA, MD, ME, MG, MK, MN, MW, MX, MY, MZ, NA, NG, NI, NO, NZ, OM, PA, PE, PG, PH, PL, PT, QA, RO, RS, RU, RW, SA, SC, SD, SE, SG, SK, SL, ST, SV, SY, TH, TJ, TM, TN, TR, TT, TZ, UA, UG, US, UZ, VC, VN, WS, ZA, ZM, ZW.

(84) Designated States (unless otherwise indicated, for every kind of regional protection available): ARIPO (BW, GH, GM, KE, LR, LS, MW, MZ, NA, RW, SD, SL, ST, SZ, TZ, UG, ZM, ZW), Eurasian (AM, AZ, BY, KG, KZ, RU, TJ, TM), European (AL, AT, BE, BG, CH, CY, CZ, DE, DK, EE, ES, FI, FR, GB, GR, HR, HU, IE, IS, IT, LT, LU, LV,

(54) Title: LOCKING APPARATUSES, SYSTEMS, AND METHODS OF PROVIDING ACCESS CONTROL

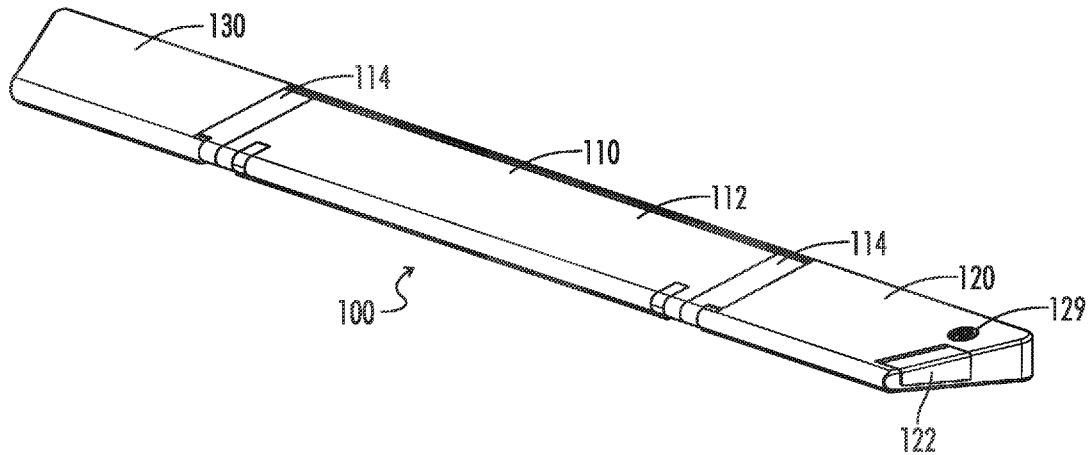


FIG. 1

(57) Abstract: Apparatuses, systems, and methods are provided for detecting an alert status of a locking apparatus for an entry point. An external force may be received at a locking apparatus operating in a locked state and determining a first indicia corresponding to the received external force, separately receiving an indication of the external force at an accelerometer of the locking apparatus and determining a second indicia corresponding to the received indication of the external force, comparing the first indicia and the second indicia to determine an alert condition, and selectively performing at least one alert operation corresponding to the determined alert condition.



MC, MK, MT, NL, NO, PL, PT, RO, RS, SE, SI, SK, SM,  
TR), OAPI (BF, BJ, CF, CG, CI, CM, GA, GN, GQ, GW,  
KM, ML, MR, NE, SN, TD, TG).

**Published:**

— *with international search report (Art. 21(3))*

**DESCRIPTION**  
**LOCKING APPARATUSES, SYSTEMS, AND METHODS OF  
PROVIDING ACCESS CONTROL**

**TECHNICAL FIELD**

[0001] The present disclosure related generally to an apparatus for resisting movement of an object. More specifically, the present disclosure relates to a mounted locking apparatus which is configured to prevent a door or other means of entry from being opened while the locking apparatus is in a locked state.

**BACKGROUND ART**

[0002] Traditional door lock mechanisms such as deadbolt locks are used to prevent or resist access to an interior of a location. Traditional deadbolt lock mechanisms are well known in the art. However, deadbolts can often be overcome with no tools and relatively little force. This may occur because the deadbolt must be mounted within the door itself and secured to a door frame. A deadbolt, mounted within the door, typically extends from the inner body of the door and into a small recess within the door face. In order for an intruder to break through a door locked using a typical deadbolt mechanism, the intruder need only kick the door at the weakest point, the lock strike plate. Even when fully engaged, a deadbolt is only able to apply resistive force across a small area of a door and door frame. Furthermore, traditional deadbolts are easily defeated, for example by lock bumping.

[0003] Therefore, in order to increase security and to protect against traditional door lock mechanism shortcomings, what is needed is an improved locking apparatus capable of providing greater strength and resiliency.

**DISCLOSURE OF THE INVENTION**

[0004] In accordance with aspects of the invention, apparatuses, systems, and methods are provided for enabling intrusion detection and prevention at a premises, including a control system therefore and control method.

[0005] According to a first aspect of the present disclosure, provided is a method of detecting an alert status of a locking apparatus for an entry point. The method includes receiving an external force at a locking apparatus operating in a locked state and determining a first indicia corresponding to the received external force, separately receiving an indication of the external force at an accelerometer of the locking apparatus and determining a second indicia corresponding to the received indication of the external force, comparing the first indicia and the second indicia to determine an alert condition, and selectively performing at least one alert operation corresponding to the determined alert condition.

[0006] The determining the first indicia corresponding to the received external force may include determining an amount of flex of a lifting member of a locking apparatus caused by the external force. The external force may be a force of a door opening inwardly into an interior space securable by the locking apparatus.

[0007] The first indicia may be determined according to a status of an electromechanical switch of the locking apparatus.

[0008] The comparing the first indicia and the second indicia may include determining a sensitivity setting and applying the sensitivity setting to a result of the comparing the first indicia and the second indicia to determine the alert condition.

[0009] The alert condition may include transmitting an indication of the alert condition to an external device. The transmitting the indication of the alert condition may include wirelessly transmitting the indication of the alert condition. The transmitting the indication of the alert condition to the external device may include wirelessly transmitting the indication of the alert condition to an electronic device associated with the locking apparatus.

[0010] According to a further aspect of the present disclosure, provided is a locking apparatus including a body, a lifting member coupleable to the body, at least a portion of the lifting member configured to move relative to the body according to a command position relating to a locking status, the lifting member comprising (i) a contact surface configured to restrict movement of an object, and (ii) an electromechanical switch, the lifting member configured to receive an external force, an accelerometer coupled to the body, the accelerometer configured to receive an indication of the external force received at the lifting member, and a control circuit configured to determine a first indicia corresponding to the received external force at the lifting member and to determine a second indicia corresponding to the received indication of the external force by the accelerometer.

[0011] The control circuit may compare the first indicia and the second indicia to determine an alert condition; and to selectively perform at least one alert operation corresponding to the determined alert condition. The control circuit may determine a sensitivity setting and applying the sensitivity setting to a result of the comparing the first indicia and the second indicia to determine the alert condition.

[0012] The control circuit may determine an amount of flex of the lifting member caused by the external force. The locking apparatus may restrict movement of a door into an interior space securable by the locking apparatus, and wherein the external force is a force of the door opening inwardly into the interior space securable by the locking apparatus.

[0013] The locking apparatus may include a transceiver, and the control circuit may control the transceiver to communicate a representation of the determined alert condition. The control circuit may cause the transceiver to wirelessly transmit the representation of the determined alert condition.

[0014] According to a still further aspect of the present disclosure, provided is a method of controlling a locking apparatus. The method includes selecting a threshold value, the threshold value corresponding to a force value associated with the locking apparatus, detecting a force received at the locking apparatus, comparing the detected force to the selected threshold value, determining an alarm condition status based at least in part upon the comparison of the detected force to the selected threshold value, and

selectively performing at least one alarm operation corresponding to the determined alarm condition status.

[0015] Determining the alarm condition status may include determining a locking status of the locking apparatus. The locking status of the locking apparatus may be determined to be a locked status, the determining the alarm condition status including providing a time delay after determining that the locking apparatus is in the locked state. The alarm condition status may be determined to be a no alarm status when the locking apparatus is determined to be operating in an unlocked status after expiration of the time delay. The alarm condition status may be determined to be an active alarm status when the locking apparatus is determined to be operating in the locked status after expiration of the time delay, wherein a control circuit of the locking apparatus transmits at least one alarm status communication responsive to the active alarm status determination.

[0016] Numerous other objects, features, and advantages of the present invention will be readily apparent to those skilled in the art upon a reading of the following disclosure when taken in conjunction with the accompanying drawings.

#### **BRIEF DESCRIPTION OF THE DRAWINGS**

[0017] FIG. 1 is an elevated perspective view of a locking apparatus according to an exemplary embodiment.

[0018] Fig. 2 is an elevated perspective view of an interior section of a power housing of a locking apparatus according to an exemplary embodiment.

[0019] Fig. 3 top internal view of an outer housing of a locking apparatus according to an exemplary embodiment.

[0020] Fig. 4 is an elevated perspective view of an interior portion of a central member of a locking apparatus according to an exemplary embodiment.

[0021] Fig. 5 is a bottom view of a locking apparatus according to an exemplary embodiment.

[0022] Fig. 6 is a side view of a locking apparatus and a riser according to an exemplary embodiment.

[0023] Fig. 7 is a side view of a locking apparatus and a connection plate according to an exemplary embodiment.

[0024] Fig. 8 is a side view of a locking apparatus in a locked state according to an exemplary embodiment.

[0025] Fig. 9 is a side view of a locking apparatus in an unlocked state according to an exemplary embodiment.

[0026] Fig. 10 is an overhead view of a sliding door Implementation of a locking apparatus in a locked state according to an exemplary embodiment.

[0027] Fig. 11 is an overhead view of a sliding door Implementation of a plurality of locking apparatuses in unlocked states according to an exemplary embodiment.

[0028] Fig. 12 is a side view of a mounting bracket for a locking apparatus and a locking apparatus according to an exemplary embodiment.

[0029] Figs. 13A-B respectively illustrate a locking apparatus in a locked state and a locking apparatus in an unlocked state according to an exemplary embodiment.

[0030] FIG. 14 is a side view of a locking apparatus having a slot-type connection point according to an exemplary embodiment.

[0031] Fig. 15 illustrates a partial internal view of a central member of a locking apparatus according to an exemplary embodiment.

[0032] Fig. 16 illustrates a partial bottom perspective view of a central member in according to an exemplary embodiment.

[0033] Fig. 17 illustrates a zoomed view of a partial internal view of a central member according to an exemplary embodiment.

[0034] Fig. 18 illustrates a partial top elevational view of a central member according to an exemplary embodiment.

[0035] FIG. 19 illustrates a raised perspective view of a portion of an internal view of a central member according to an exemplary embodiment.

[0036] Fig. 20 illustrates a top perspective view of a locking apparatus according to an exemplary embodiment.

[0037] Fig. 21 illustrates a perspective view of a partial internal view of a central member and an outer housing of a locking apparatus according to an exemplary embodiment.

[0038] FIG. 22 illustrates a flowchart of an exemplary embodiment of a process of performing a detection process for a locking apparatus according to aspects of the present disclosure.

[0039] FIG. 23 illustrates a partial top view of a block diagram of an exemplary embodiment of a locking apparatus according to aspects of the present disclosure.

[0040] FIG. 24 illustrates a partial block diagram of an exemplary embodiment of a control circuit according to aspects of the present disclosure.

#### **BEST MODE FOR CARRYING OUT THE INVENTION**

[0041] While the making and using of various exemplary embodiments of the present disclosure are discussed in detail below, it should be appreciated that the present disclosure provides many applicable inventive concepts that can be embodied in a wide variety of specific contexts. The specific embodiments discussed herein are merely illustrative of specific ways to make and use the invention and do not delimit the scope of the invention.

[0042] Where the various figures may describe embodiments sharing various common elements and features with other embodiments, similar elements and features are given the same reference numerals and redundant description thereof may be omitted below.

[0043] To facilitate the understanding of the embodiments described herein, a number of terms are defined below. The terms defined herein have meanings as commonly understood by a person of ordinary skill in the areas relevant to the present invention. Terms such as “a,” “an,” and “the” are not intended to refer to only a singular entity, but rather include the general class of which a specific example may be used for illustration. The terminology herein is used to describe specific embodiments of the invention, but their usage does not delimit the invention, except as set forth in the claims. The phrase “in one embodiment,” as used herein does not necessarily refer to the same embodiment, although it may.

[0044] Conditional language used herein, such as, among others, “can,” “might,” “may,” “e.g.,” and the like, unless specifically stated otherwise, or otherwise understood within the context as used, is generally intended to convey that certain embodiments include, while other embodiments do not include, certain features, elements and/or states. Thus, such conditional language is not generally intended to imply that features, elements and/or states are in any way required for one or more embodiments or that one or more embodiments necessarily include logic for deciding, with or without author input or prompting, whether these features, elements and/or states are included or are to be performed in any particular embodiment.

[0045] The term “signal” as used herein may include any meanings as may be understood by those of ordinary skill in the art, including at least an electric or magnetic representation of current, voltage, charge, temperature, data or a state of one or more memory locations as expressed on one or more transmission mediums, and generally capable of being transmitted, received, stored, compared, combined or otherwise manipulated in any equivalent manner.

[0046] The term “user interface” as used herein may unless otherwise stated include any input-output module with respect to the hosted server including but not limited to web portals, such as individual web pages or those collectively defining a hosted website, mobile applications, desktop applications, telephony interfaces such as interactive voice response (IVR), and the like. Such interfaces may in a broader sense include pop-ups or links to third party websites for the purpose of further accessing and/or integrating associated materials, data or program functions via the hosted system and in accordance with methods of the present invention.

[0047] The terms “controller,” “control circuit” and “control circuitry” as used herein may refer to, be embodied by or otherwise included within a machine, such as a general purpose processor, a digital signal processor (DSP), an application specific integrated circuit (ASIC), a field programmable gate array (FPGA) or other programmable logic device, discrete gate or transistor logic, discrete hardware components, or any combination thereof designed and programmed to perform or cause the performance of the functions described herein. A general-purpose processor can be a microprocessor, but in the alternative, the processor can be a controller, microcontroller, or state machine, combinations of the same, or the like. A processor can also be implemented as a combination of computing devices, e.g., a

combination of a DSP and a microprocessor, a plurality of microprocessors, one or more microprocessors in conjunction with a DSP core, or any other such configuration.

[0048] The term “communications medium” as used herein with respect to data communication between two or more parties or otherwise between communications network interfaces associated with two or more parties may refer to any one of, or a combination of any two or more of, telecommunications networks (whether wired, wireless, cellular or the like), a global network such as the Internet, local networks, network links, Internet Service Providers (ISP’s), and intermediate communication interfaces.

[0049] To the extent that the term “includes” or “including” is used in the specification or the claims, it is intended to be inclusive in a manner similar to the term “comprising” as that term is interpreted when employed as a transitional word in a claim. Furthermore, to the extent that the term “or” is employed (e.g., A or B) it is intended to mean “A or B or both.” When the applicants intend to indicate “only A or B but not both” then the term “only A or B but not both” will be employed. Thus, use of the term “or” herein is the inclusive, and not the exclusive use. See, Bryan A. Garner, *A Dictionary of Modern Legal Usage* 624 (2d. Ed. 1995). Also, to the extent that the terms “in” or “into” are used in the specification or the claims, it is intended to additionally mean “on” or “onto.” Furthermore, to the extent the term “connect” is used in the specification or claims, it is intended to mean not only “directly connected to,” but also “indirectly connected to” such as connected through another component or multiple components.

[0050] With reference to FIG. 1, provided is a locking apparatus 100 in accordance with an exemplary embodiment of the present disclosure. Locking apparatus 100 may comprise a central member 110 having a lifting member 112 and at least one stop member 114 located at an end thereof. In one embodiment, the locking apparatus 100 may comprise one or more of an outer housing 120 and power housing 130 connected thereto. The locking apparatus 100 may be modularly formed of a central member 110 and one or more of outer housing 120 and power housing 130. As used herein, the term “central” may denote aspects other than or in addition to a physical location. For example, the term “central” as used herein may convey an operational aspect and/or interrelationship as applied. In one exemplary embodiment, at least one of the outer housing 120 and power housing 130 may be physically located at a central location of an assembled locking apparatus 100 without departing from the spirit or scope of the present disclosure. Although described with reference to a lock or locking, it should be appreciated that the locking apparatus 100 functionally operates as a barrier to restrict movement of an object, and thus should not be narrowly construed as merely a traditional lock, and does not require a particular “key” or physical or electronic unlocking device to operate. Accordingly, the locking apparatus 100 may take the form of a barrier apparatus consistent with the disclosure provided herein.

[0051] In one embodiment, the overall structure of the locking apparatus 100 may form a convex quadrilateral such as a trapezoid. In the exemplary embodiment illustrated at FIG. 1, for example, the central member 110 may be rectangularly shaped, while the outer housing 120 and power housing 130

may be shaped as a trapezoid. However, the shape of each of the central member 110, outer housing 120, and power housing 130 may vary based upon desired usage, thus an overall shape of the locking apparatus 100 may vary.

**[0052]** At least a portion of lifting member 112 of central member 110 may be configured to elevate during operation of the locking apparatus 100. In one exemplary embodiment described herein, at least a portion of the lifting member 112 may be elevated more at a proximal side of the locking apparatus 100 relative to a door frame than at a distal side relative to the door frame. In doing so, a force applied at the lifting member 112 by contact with a door or other object may be translated downwardly along the lifting member 112 and into a surface to which the locking apparatus is mounted, thereby increasing an amount of force capable of being resisted by the locking apparatus 100.

**[0053]** An inner portion of the lifting member 112 may comprise notches, divots, or cam receptacles. The notches, divots, or cam receptacles may be configured to be placed in contact with at least one cam 440 (as illustrated at FIG. 4 and described herein) of the central member 110. In one embodiment, the at least one cam 440 may be placed in constant contact with the lifting member 112 during operation. In an alternate embodiment, the at least one cam 440 may be configured to be placed in contact with the lifting member 112 only during particular operations, such as increasing a height of the lifting member 112 and/or decreasing the height of the lifting member 112.

**[0054]** The lifting member 112 may comprise a single structural element in one embodiment or may comprise a plurality of structural elements without departing from the spirit and scope of the present disclosure. For example, in one embodiment the lifting member 112 may be formed of two or more structural elements which are configured to nest within each other when the locking apparatus 100 operates in an unlocked state, and to expand to separate associated heights when operating in a locked state. In one implementation, at least one of the plurality of structural elements may be selected based on a desired overall height of the lifting member 112 in a locked state. In a separate embodiment, the plurality of structural elements may collectively be arranged at a single height when in a locked position, and/or may provide for a single or a plurality of contact points with a door or object whose movement is intended to be restricted. When a plurality of nested structural elements are used for lifting member 112, a gap distance between a contact surface of the lifting member 112 and the door or object whose movement is intended to be restricted may be reduced as compared to a single lifting member embodiment. In addition to lifting member 112, a height of the at least one stop member 114 may be manipulated within the scope of the present disclosure. This may be accomplished, for example, based on a connection between the lifting member 112 and at least one stop member 114 and/or by connection between at least one cam 440 and the at least one stop member 114.

**[0055]** In one embodiment, locking apparatus 100 may comprise a single central member 110 without either or both of outer housing 120 and power housing 130 connected thereto. In another embodiment, one or more central members 110 may be connected to form a single locking apparatus 100. In this

configuration, the plurality of central members 110 may communicate with one another to coordinate operation and function as a single member. In an alternate embodiment, a plurality of central members 110 may be interconnected as separate locking apparatuses 100, each operating independently of one another. Because of the modular nature of locking apparatus 100, a size associated with each component of the locking apparatus 100 may vary, and the ultimate size of a locking apparatus 100 depends on a size and number of each central member 110, outer housing 120, and/or power housing 130 connected thereto. Each of the central member 110, outer housing 120, and/or power housing 130 may be implemented in various sizes to permit usage in any intended application. For example, a central member 110 may be implemented having various widths and associated contact surface size, such that a central member 110 may have a width such as ten inches, thirty-six inches, or any other desired size based on implementation.

**[0056]** Outer housing 120 may be configured to physically and/or electrically connect to a central member 110. For example, an outer housing 120 may be connected to a central member 110 by moving the outer housing 120 inwardly towards the at least one stop member 114. In this example, the outer housing 120 or central member 110 may comprise a connection mechanism which detachably connects the outer housing 120 and central member 110 when the outer housing 120 is moved inwardly relative to the central member 110. Alternatively or in conjunction with attachment to the central member 110, the outer housing 120 and central member 110 may connect via at least a portion of the at least one stop member 114.

**[0057]** Each of the central member 110, outer housing 120, and/or power housing 130 may be formed of a durable material and each form a cavity therein. Examples of durable materials which may be used are glass-filled nylon such as nylon 66, metals such as aluminum, titanium, or the like, plastics, or any other material capable of structural rigidity sufficient for operating conditions of the locking apparatus 100. The central member 110, outer housing 120, and power housing 130 may each have a cavity formed therein configured to house internal components.

**[0058]** When combined, the locking apparatus may be configured to be arranged in an elongated structure with one or more central members 110, outer housings 120, and/or power housings 130 connected at one or more of opposing longitudinal ends of a central member 110. At least one other central member 110, outer housing 120, or power housing 130 may, in various embodiments, be attached to a central member 110 at any surface of the central member 110, based on a desired operational configuration (e.g., at a location other than a longitudinal end). Electrical connection(s) between internal components of central member 110 and between central member 110, outer housing 120, and power housing 130 may be accomplished by means of conventional wiring and connectors, which are not illustrated in the drawings for purposes of promoting clarity.

**[0059]** In one exemplary embodiment, the outer housing 120 may be configured with a locking mechanism 122 housed therein. Locking mechanism 122 may optionally be configured as a push/pull

type manual unlock, a pressure sensitive foot pedal, or any other means of manual operation capable of engaging and/or disengaging an operational status of the locking apparatus 100. As illustrated, for example, in FIG. 2, a push-pull type mechanism may comprise an operating arm 224, crossmember 226, and engagement arm 228. Operating arm 224 and engagement arm 228 may be connected to each other by means of interconnection with the crossmember 226. Although crossmember 226 is illustrated in FIG. 2 as being connected to operating arm 224, engagement arm 228, and a central pivot point 227 by means of screws or bolts, any fastening means capable of attaching the crossmember 226 to the operating arm 224, engagement arm 228, and pivot point 227 may be used within the spirit and scope of the present disclosure.

**[0060]** In operation, the locking mechanism 122 may be configured to permit manual engagement or disengagement of the locking apparatus 100. For example, in one exemplary embodiment, the locking mechanism 122 may be configured such that at least a portion of operating arm 224 extends to protrude from an outer surface of the outer housing 120 when the locking apparatus 100 operates in a locked mode. If a user desires to manually disengage the locking apparatus 100, the user may push the operating arm 224 inwardly towards the central member 110. The movement of the operating arm 224 may cause the crossmember 226 to rotate relative to the pivot point 227, for example in either a clockwise or counterclockwise direction. Based on its attachment to the engagement arm 228, crossmember 226's rotation may cause the engagement arm 228 to move in an engagement direction. In one embodiment, the engagement direction may be a longitudinal direction associated with the central member 110. Movement in the engagement direction may activate a manual release 420 of actuator 405 (illustrated at FIG. 4) to manipulate an operating status of the locking apparatus 100 in a manner as described herein.

**[0061]** Either alternatively or in addition to a push/pull type mechanism, other means of manual operation are contemplated within the scope of the present disclosure. For example, a foot pedal (not illustrated) may be used at an outer surface of the outer housing 120 to manipulate a manual release associated with the locking apparatus 100. For example, a foot pedal 54 and associated structure as described in Provisional Patent Application 62/038,393 (as incorporated by reference herein in its entirety) may be implemented for manual operation.

**[0062]** Outer housing 120 may further comprise an illuminating member 129. Illuminating member 129 may comprise a lighting element such as a light emitting diode (LED) or the like which is powered either by a power source (e.g., a battery or other input power) associated with the outer housing 120, or by an electrical connection to central member 110 or power housing 130. In one embodiment, a faceplate containing a logo or other item desired to be illuminated may be placed atop the illuminating member 129 to provide backlighting for the faceplate. In one exemplary embodiment, the illuminating member 129 may be configured to vary an illumination color based on a status of the locking apparatus 100. For example, the illuminating member 129 may display a first color while the locking apparatus operates in an unlocked mode, while a second color may be displayed while the locking apparatus operates in a

locked mode. The illuminating member 129 may also be configured to vary a color or display mode for purposes of conveying information to a user. For example, the illuminating member may provide various color or display patterns to convey lock status, information related to usage (e.g., battery backup power usage, etc.), device pairing status, or any other information desired to be conveyed by the locking apparatus 100. Electrical connection(s) between internal components of outer housing 120 and between outer housing 120 and central member 110 may be accomplished by means of conventional wiring and connectors, which are not illustrated in the drawings for purposes of promoting clarity.

**[0063]** In one embodiment, one or more power housings 130 may be connected to a central member 110. As illustrated in FIG. 3, power housing 130 may comprise one or more of a power input 132 and battery 134. Power input 132 may be configured to be located at an outer surface of the power housing 130 and to receive input power from an external source (e.g., a power adapter or other power input means). In one embodiment, the power input 132 may be connected to the battery 134 and may be configured to provide charging power to the battery 134 when a power source is connected to the power input 132. Electrical connection(s) between internal components of power housing 130 and between power housing 130 and central member 110 may be accomplished by means of conventional wiring and connectors, which are not illustrated in the drawings for purposes of promoting clarity.

**[0064]** Battery 134 may comprise a lithium-ion, aluminum-ion, sodium-nickel chloride, polymer, or other battery design which is configured to provide sufficient power storage, durability, and/or thermal properties. Alternatively or in addition to the above-noted battery designs, battery 134 may comprise or include at least one ultracapacitor. In one exemplary embodiment, the battery 134 may comprise a rechargeable lithium-ion battery. The location of battery 134 and design within the power housing 130 may be configured so as to increase the longevity of holding a charge and to prevent damage to the battery 134 (e.g., by means of water damage, electrical charge, or wear and tear). The battery 134 may be positioned within the cavity of the power housing 130. In one embodiment, the battery 134 may be located within an insulated compartment 136. The insulated compartment 136 may be configured to be waterproof and to electrically insulate the battery 134 therein.

**[0065]** In one embodiment a battery backup 135 may be used either as part of battery 134 or as a standalone backup. The battery backup 135 may comprise, for example, one or more alkaline batteries electrically connected to the locking apparatus 100. The battery backup 135 may be used to provide power to the locking apparatus 100 in the event that the battery 134 has insufficient capacity or is incapable of meeting a power demand of the battery 134. For example, the battery backup 135 may provide power in the event that battery 134 is fully discharged, is not operating properly, or is low on power. In an exemplary embodiment, the one or more alkaline batteries may be selected so as to provide six months or more of operating the locking apparatus 100 according to ordinary usage. The battery backup 135 may comprise three AAA batteries in one embodiment.

[0066] In one exemplary embodiment, the locking apparatus 100 may provide a notice to a user that the locking apparatus 100 is operating on battery backup power. The locking apparatus 100 may communicate a status to a user in a number of ways. For example, the locking apparatus 100 may emit a noise such as a beep, either continuously or at a specified interval, the illuminating member may blink to indicate backup power, the locking apparatus 100 may transmit an electronic communication to convey backup power usage to a user, etc.

[0067] Power housing 130 may be configured to provide electrical power to the central member 110, for example by use of matching connectors 138 located at the power housing 130 and central member 110. In one exemplary embodiment the matching connectors may be located within at least one of the cavities of the power housing 130 and central member 110. For example, power housing 130 may comprise a power housing connector 138 configured to electrically connect to a corresponding connector of central member 110. In one embodiment, the corresponding connector of central member 110 may be associated with a stop member 114; however the corresponding connector of central member 110 may additionally or alternatively be associated with the central member 110 of itself or internal component therein.

[0068] FIG. 4 illustrates internal components within the cavity of central member 110 according to an exemplary embodiment. A bottom surface of the central member 110 may comprise a base 401 (e.g., a body). At least one opening 402 may be formed in the base 401 at a distal side of the central member 110 relative to a door frame. The at least one opening 402 may have at least one rotation-enabling member 403 to permit at least a portion of lifting member 112 to elevate during operation. Central member 110 may further comprise an actuator 405. Actuator 405 may be variously implemented to provide for lifting power necessary to raise and/or lower lifting member 112 during operation. In one exemplary embodiment, the actuator 405 may comprise a servo; however any actuating device capable of manipulating a physical location of lifting member 112 may be used within the spirit and scope of the present disclosure. The actuator 405 may be mounted to the base 401 using mount 415 attached to or formed by the base 401. Actuator 405 may comprise a coupler 410 for connecting to an external translating member. In one embodiment, actuator 405 may be configured to provide an output corresponding to a locked and an unlocked state. For example, the actuator 405 may be configured in one embodiment to provide output rotation at a designated amount in a designated direction corresponding to each state.

[0069] Actuator 405 may further comprise a manual release 420. Manual release 420 may be configured to receive an input and to transition actuator 405 to a different operating state. For example, the manual release 420 may be configured to transition actuator 405 to an unlocked state from a locked state when an input is received from locking mechanism 122. Alternatively, the manual release 420 may be configured to permit purely manual operation by changing an operating state of the locking apparatus

100 when an input is received (i.e., by switching between a current locked state to an unlocked state or between a current unlocked state to a locked state upon receiving input).

**[0070]** In one embodiment, the coupler 410 of actuator 405 may attach to a shaft 425 at a shaft coupler 430. As illustrated, for example, at FIG. 4, the coupler 410 of actuator 405 and the shaft coupler 430 of shaft 425 may be implemented using matching notches to permit interconnection. However, connecting notches are not required to be used to connect the actuator 405 and shaft 425, and in one embodiment, the shaft 425 may connect directly to the actuator 405. The shaft 425 may be connected to the base 401 of central member 110 by means of at least one coupler 435. The at least one coupler 435 may be configured to hold the shaft 425 in position relative to the base 401, actuator 405, and/or lifting member 112,

**[0071]** At least one cam 440 may be connected to the shaft 425. The at least one cam 440 may be configured to rotate in a manner consistent with shaft 425 during operation, and may be placed in contact with an inner surface of the lifting member 112. Although two cams 440 are illustrated in FIG. 4, only one cam 440 may be used, or three or more cams 440 may be used without departing from the spirit and scope of the present disclosure. In one embodiment the at least one cam 440 may be positioned relative to the shaft 425 such as to reduce potential damage to components of the central member 110 when an external force is applied to lifting member 112 or any other portion of locking apparatus 100. Furthermore, the at least one cam 440 may be configured to maintain an angle relative to the lifting member 112 such that an external force applied to the lifting member 112 or other portion of locking apparatus 100 will not cause the at least one cam 440 to move or the shaft 425 to rotate. As such, in one embodiment, the configuration of the at least one cam 440 and shaft 425 may be such that structural rigidity and locking integrity is increased.

**[0072]** In one embodiment, the actuator 405 may cause the shaft 425 to rotate the at least one cam 440 such that an external surface of the lifting member 112 attains a predetermined angle relative to a surface upon which the locking apparatus 100 is mounted. The predetermined angle may be determined at a time of manufacture or may be configured by a user. The predetermined angle may be configured such that a contact position of the at least one cam 440 is perpendicular to the lifting member 112. The predetermined angle may vary based upon intended operation. For example, a smaller angle may be preferable where a small distance exists between a surface that the locking apparatus 100 is mounted upon and an object whose movement is to be retrieved, when compared to a greater distance. Alternatively, a larger angle may be preferable to resist an external force pushing downward upon an exterior surface of the lifting member 112. In one exemplary embodiment, a predetermined angle of between 15 and 20 degrees may be used. However, any angle may be used within the scope of the present disclosure for a corresponding intended purpose.

**[0073]** Central member 110 may further comprise a control circuit 450. In one embodiment, the control circuit 450 may be attached to the base 401 by means of circuit mount 460. In one embodiment, control

circuit 450 is configured to control power distribution within the locking apparatus 100 and to enable automated control of the locking apparatus 100. In one exemplary embodiment, the control circuit 450 may comprise a transceiver 455 to send and receive control signals. In one embodiment, the transceiver 455 may comprise a wired or wireless connection medium. At least a portion of the transceiver 455 may be accessible from an outer surface of the locking apparatus 100 or may be wholly within the cavity of the central member 110. Transceiver 455 may permit communications across a communication medium using known communications protocols or proprietary communication protocols. For example, the transceiver 455 may permit the use of Ethernet, Bluetooth, Wi-Fi, a wireless application protocol, an IEEE 802 standard, or any other communications protocol, configuration, or implementation. It should be appreciated that in various embodiments, the locking apparatus 100 may be configured in a manual operating mode, without using or requiring the control circuit 450.

**[0074]** In one exemplary embodiment, the transceiver 455 may be configured to communicate with a software application running on a device. For example, the transceiver 455 may be configured to send and receive messages relating to a user device running the software application (e.g., by means of a user interface executed upon a device). The software application may be configured such that a user of the software may cause the control circuit 450 to actuate various operations corresponding to a user's command. For example, the software may enable a user to request that the locking apparatus 100 operate in either a locked or unlocked state. Upon receiving a requested operation at the transceiver 455, the control circuit 450 may control the locking apparatus 100 to perform the desired operation. The control circuit 450 may permit a great variety of desired automation and remote control capabilities. For example, in one exemplary embodiment, the control circuit 450 may be paired with a user device (e.g., using the Bluetooth protocol). After pairing, the control circuit 450 may be programmed to ensure that the locking apparatus 100 operates in an unlocked state whenever the paired user device is within a predetermined distance of the locking apparatus 100 (e.g., within ten feet).

**[0075]** Similarly, the control circuit 450 may, in one embodiment, permit the locking apparatus 100 to detect at least one device other than a paired user device and to notify an owner of the locking apparatus of an identifier associated with the detected device and/or provide the ability to remotely transition the locking apparatus 100 to a locked or unlocked state. The control circuit 450 may further enable the locking apparatus 100 to be programmed to operate in a locked or unlocked state at a predetermined time or event in one embodiment.

**[0076]** FIG. 5 illustrates a bottom view of an assembled locking apparatus according to an exemplary embodiment. As illustrated, central member 110 may comprise a bottom surface 510, outer housing 120 may comprise a bottom surface 520, and power housing 130 may comprise a bottom surface 530. Each of the bottom surfaces 510, 520, and 530 may be configured to include at least one mounting location 550. Each mounting location 550 may be used to secure the locking apparatus 100 to a surface upon which it is intended to be mounted.

[0077] Locking apparatus 100 may be attached to a surface upon which it is intended to be mounted using any one of at least one bolt, at least one hook and loop fastener, an adhesive material (e.g., any double sided tape, a tape such as 3M™ VHB™, etc.), or any other means of attachment, either alone or in combination. Furthermore, the means of attaching the locking apparatus 100 to the surface upon which it is intended to be mounted may be located upon at least one surface of the locking apparatus 100, the surface upon which it is intended to be mounted, or any combination thereof. In one exemplary embodiment, the locking apparatus 100 may comprise at least one opening at a bottom surface thereof which may be used to mount the locking apparatus 100 to an intended mounting location by placing a bolt, screw, nail, tape, or other affixing element into or through the at least one opening and into or onto the surface upon which the locking apparatus 100 is intended to be mounted. Optionally, the at least one opening may be provided by means of a mounting bracket configured to be placed between the locking apparatus 100 and mounting surface during installation.

[0078] At least one of the central member 110, outer housing 120, and power housing 130 may be placed in contact with a threshold and/or door frame to provide bracing and/or structural rigidity. The locking apparatus 100 may optionally be mounted to the threshold and/or door frame by means the same or similar mounting means as described herein.

[0079] In addition to use of a predetermined angle, other mechanisms for adjusting to a height between a surface upon which the locking apparatus 100 is mounted and a door height are contemplated within the scope of the present disclosure. For example, as illustrated at FIG. 6, a riser 600 may be used to increase an overall height of the locking apparatus 100. In one embodiment, the locking apparatus 100 may be mounted to the riser 600. The locking apparatus 100 may be mounted to the riser 600 at mounting point 610. Mounting point 610 may comprise any means of attaching the locking apparatus 100 to the riser 600 and/or surface 620. In one embodiment, the locking apparatus 100 may be attached to the riser 600 using screws or other fastening means.

[0080] The locking apparatus 100 may optionally be attached to the riser 600 using any single element or combination of at least one bolt, at least one hook and loop fastener, an adhesive material (e.g., any double sided tape, a tape such as 3M™ VHB™, etc.), or any other means of attachment. Furthermore, the means of attaching the locking apparatus 100 to the riser 600 may be located upon at least one surface of the locking apparatus 100, at least one surface of the riser 600, or any combination thereof.

[0081] In an alternative exemplary embodiment, a riser 600 may be placed atop an upper surface of lifting member 112 to increase an overall height thereof. In this configuration, the riser 600 may be attached directly to a top surface of riser 600 or may be attached to any portion of the locking apparatus 100 where such attachment is capable of preventing movement of the riser 600 relative to the locking apparatus 100.

[0082] In one exemplary embodiment, the riser 600 may be configured to conform to legal requirements for threshold height. For example, the riser 600 may be configured or adjusted to satisfy a one-half inch

height requirement in accordance with the Americans with Disabilities Act (ADA). Because threshold height may vary widely based upon installation and indoor floor height, riser 600 may be used to help satisfy ADA height requirements, as well as to form an ideal contact surface between the locking apparatus 100 and an object whose movement is intended to be restricted. In one embodiment, the riser 600 may, for example, provide for at least one inch of lift and/or at least 30 degrees of elevation to the lifting member 112.

**[0083]** In one embodiment, the locking apparatus 100 may be configured to attach to a connection plate 700, as illustrated at FIG. 7. Connection plate 700 may be formed of any durable and/or rigid material capable of attachment to the locking apparatus 100. The connection plate 700 may be used in one embodiment to facilitate attachment of the locking apparatus 100 to the surface (e.g., surface 720) upon which the locking apparatus 100 is intended to be mounted. For example, the connection plate may provide pre-cut screw or bolt holes, may have double sided tape provided at predetermined locations, etc.

**[0084]** The connection plate 700 may be further configured to provide additional structural integrity and/or rigidity to the locking apparatus 100. In one embodiment, the connection plate may be designed for installation at a time when a door frame is installed. The connection plate 700 may be configured to be placed under door sill 710 and/or to attach to one or more surfaces of the door sill 710 in order to provide additional strength and rigidity. In one embodiment, the connection plate 700 may be connected to a sill frame and/or mounting bracket.

**[0085]** Connection plate 700 may be used either in place of or in addition to riser 600 as desired. For example, a thickness of the connection plate 700 may be adjustable or possess a thickness so as to incorporate desired features of riser 600.

**[0086]** In one embodiment, the connection plate 700 may comprise a universal installation plate (UIP) configured to permit installation of a locking apparatus according to a particular desired implementation. Although the use of a UIP is not required to be installed with a locking apparatus 100, use of a UIP may expand installation capability, for example to accommodate a particular floor surface, a distance of the locking apparatus 100 from a door frame, or a particular property makeup of a floor surface. The UIP may be configured to adjust to a plurality of door applications. A UIP may be mounted in a plurality of ways, for example, under a door threshold, between a door and a sill plate, or any other door, frame, or floor surface configuration. In one embodiment, the locking apparatus 100 may be configured to attach to a pressure treated main door sill plate associated with a foundation of a structure such as a building.

**[0087]** FIG. 8 illustrates a side view of an exemplary implantation of the present disclosure when the locking apparatus 100 is in a locked state. As illustrated in FIG. 8, a locking apparatus 100 may be mounted upon an intended mounting surface 810 (e.g., an interior floor). In the embodiment illustrated at FIG. 8, the locking apparatus 100 is mounted to the intended mounting surface 810 and/or threshold 820 using at least one fastener 815. At least one surface of the locking apparatus 100 may be optionally

placed in contact with threshold 820. Door 830 may be configured to open inwardly toward the locking apparatus 100. When door 830 is opened, it may contact the lifting member 112 of locking apparatus 100 at a contact surface  $\alpha$ . As previously described, a height of the contact surface  $\alpha$  may be manipulated using riser 600, connection plate 700, or a combination thereof (see FIGS. 6-7), to achieve an optimal contact surface area between the locking apparatus 100 and door 830.

[0088] In operation, as the door 830 is placed in contact with the contact surface  $\alpha$ , force associated with opening the door inwardly may be translated across the lifting member 112 of the locking apparatus 100 and through the bolts 815 and intended mounting surface 810 and/or threshold 820. By doing so, door opening may be resisted or prevented, and entry may be denied. Furthermore, by providing a floor-mounted locking mechanism, existing entry prevention mechanisms may be enhanced. Because forces received at the contact surface  $\alpha$  of locking apparatus 100 are translated into the intended mounting surface 810 and/or threshold 820, forces far exceeding that needed to defeat existing door lock mechanisms may be received by the locking apparatus 100 without permitting entry.

[0089] FIG. 9 illustrates a side view of an exemplary implantation of the present disclosure where the locking apparatus 100 is in an unlocked state. As shown in FIG. 9, when the locking apparatus 100 is in an unlocked state, door 830 is free to open inwardly without being placed in contact with contact surface  $\alpha$ , since contact surface  $\alpha$  is nested within the locking apparatus 100 when operating in the unlocked mode.

[0090] Although the present disclosure generally illustrates a floor-mounted locking mechanism, one or more locking apparatuses 100 in accordance with the present disclosure may be implemented at any surface upon which movement of an object to be restrained may be restricted. For example, at least one locking apparatus 100 may be positioned at a vertical portion of a door or window frame or sill and may operate in the same manner as previously described to restrict movement of an object whose movement is intended to be restricted.

[0091] For example, FIG. 10 illustrates a locking apparatus 100 configured to restrict movement of a sliding door 1000 which moves horizontally relative to a door frame 1050. In this embodiment, the locking apparatus 100 may be positioned such that when lifting member 112 is in a locked state, the sliding door 1000 is blocked from opening by either the sliding door 1000 or frame 1050 being placed in contact with the contact surface  $\alpha$  of the locking apparatus 100. As noted in FIG. 10, the locking apparatus 100 may be positioned at either of the sliding door 1000 or frame 1050 in this embodiment to provide a similar or same result.

[0092] FIG. 11 illustrates an exemplary embodiment in which sliding doors 1101 and 1102 are configured to open and close by moving along one or more tracks 1120 enclosed by rails 1150. In this exemplary embodiment, one or more locking apparatuses 100 may be implemented at each of sliding doors 1101 and 1102 to restrict movement of the doors along track 1120. For example, sliding doors 1101 and 1102 may be prevented from opening when lifting members 112 of locking apparatuses 100

are in a locked position, as contact between the contact surfaces  $\alpha$  of the locking apparatuses 100 and the rails 1150 prevent the sliding doors 1101 and 1102 from moving outwardly along rails 1150.

**[0093]** FIG. 12 illustrates a mounting bracket 1200 according to an exemplary embodiment. In one embodiment, the locking apparatus 100 may be attached to a mounting bracket 1200. Alternatively, the locking apparatus may be attached to mounting bracket 1200 at time of installation and mounting to at least one of threshold 820 and surface 1210, for example, by placing a screw, bolt, portion of double sided tape, etc. through at least one opening into which screws 1250 and/or 1275 are placed, as illustrated in FIG. 12. In one embodiment, a carpet or other top surface 1290 may be removed to properly mount the mounting bracket 1200 and locking apparatus 100 to the surface 1210. Although screw 1275 is not illustrated as penetrating through a portion of the locking apparatus 100, it should be understood that both the mounting bracket 1200 and locking apparatus 100 may be secured to the threshold 820 by means of screw 1275, for example by pre-forming a passage through an outer surface of the locking apparatus 100, or by drilling through or otherwise penetrating an outer surface of the locking apparatus 100 either before installing the screw 1275 or at the time of installing screw 1275.

**[0094]** In one embodiment, mounting bracket 1200 may be formed of metal, plastic, glass-filled nylon, or any other material capable of rigidity and durability during operation of the locking apparatus 100. In one embodiment, the connection plate 700 may be formed, at least in part, by a mounting bracket 1200. For example, the connection plate 700 may comprise mounting bracket 1200 attached to or otherwise connected with an extending portion which extends under a door frame or sill.

**[0095]** FIGS. 13A-B illustrate a locking apparatus 100 in a locked state (FIG. 13A) and in an unlocked state (FIG. 13B) in accordance with an exemplary embodiment of the present disclosure. In one embodiment, at least a portion of the at least one stop member 114 may be configured to elevate at a same or similar rate to that of lifting member 112, and may be configured to reach a positional height in a locked state of the lifting member 112 or at least a portion thereof. Each at least one stop member 114 may be configured to elevate using at least one cam in a similar manner to that of lifting member 112, or may be connected to lifting member 112 in a manner which permits a height of the at least one stop member 114 to be manipulated. Although illustrated as comprising a single surface whose height is manipulated, in one exemplary embodiment, the lifting portion may comprise a plurality of lifting sections each having respective contact surfaces with a device whose movement is intended to be restricted.

**[0096]** FIG. 14 illustrates a side view of a locking apparatus 100 according an exemplary embodiment of the present disclosure. In the embodiment illustrated by FIG. 14, at least one cam 440 may be configured with a connector 1450 at a surface thereof. The connector 1450 may be configured to be received by and connected to a slot 1460 located at an interior surface of the lifting member 112. In one embodiment, connection between the connector 1450 and slot 1460 may permit the at least one cam 440 to control both lifting and lowering of a height associated with the lifting member 112. By placing the

connector 1450 into the slot 1460, movement of the cam 440 may cause a position of the connector 1450 within the slot 1460 to move such that at least one of a lifting motion and a lowering motion is achieved based on movement of the cam 440.

**[0097]** Fig. 15 illustrates a partial internal view of an exemplary embodiment of a central member 1500 of a locking apparatus. Connected to a bottom portion 1501 of the central member 1500 may be at least one actuator 1505. In various embodiments, the actuator 1505 may be equivalent to the actuator 405 previously described herein. The actuator 1505 is configured in one embodiment to connect to at least one lifting arm 1510. The lifting arm 1510 is configured to translate rotational movement output from the actuator 1505 to cause at least one of contact with a surface of a lifting member 112 (not illustrated in FIG. 15) of a central member 1500 and movement of the lifting member 112 via the lifting arm 1510.

**[0098]** At least one adjustment member 1515 (e.g., strap 1515) may be connected one or more contact points of the central member 1500. In one exemplary embodiment, the adjustment member 1515 may comprise a material capable of flexing and translating forces received at the adjustment member 1515. The adjustment member 1515 may take the form of any substance or material capable of being placed in tension (such as, for example, a nylon strap, nylon webbing, rubber material, plastic material, a flexible woven, nonwoven, or textile member, etc.). In one exemplary embodiment, the adjustment member 1515 is a flexible woven or textile strap. However, the adjustment member 1515 is capable of taking the form of any segment, strand, or portion of material capable of receiving and/or transmitting one or more forces (e.g., a rope, string, or strand of material, a segment or portion of substance, etc., without departing from the spirit and the scope of the present disclosure.

**[0099]** The adjustment member may include one or more contact terminals 1517. Each contact terminal 1517 is configured to connect to at least a portion of the central member 1500. For example, one or more contact terminal 1517 may be configured to connect to a corresponding pin located at a lifting member 112 associated with the central member 1500. The adjustment member 1515 and central member 1500 are configured in one exemplary embodiment such that at least a portion of the adjustment member 1515 is wound or wrapped around a portion of a contact surface of the central member. For example, as illustrated in FIG. 15, the adjustment member 1515 may be wound through one or more apertures 1519 in a portion of the central member 1500. The adjustment member 1515 is configured to connect to the lifting member 112 at two contact terminals 1517 while also being looped through one or more apertures 1519 in the exemplary embodiment illustrated by FIG. 15. By doing so, the adjustment member is placed in tension and may absorb and translate forces received at one or more portions of the central member 1500.

**[00100]** The central member 1500 may comprise at least one dog 1530. In one exemplary embodiment, dog 1530 is configured to connect to a surface of the bottom portion 1501. The dog 1530 may be rotatively coupled to a dog leg (e.g., latch), the dog leg being configured to restrict or stop movement of the dog 1530 in at least one direction. The dog 1530 includes a contact means 1540, for example at an

end of the dog 1530 opposite to that connected to the bottom portion 1501. The contact means 1540 may variously comprise one or more connection mechanisms configured to be placed in contact and/or remain in contact with a surface of the lifting member 112 during operation. For example, the contact means 1540 may take the form of a pin, a roller, a bearing, or the like, without departing from the spirit and the scope of the present disclosure. In one exemplary embodiment, the contact means 1540 may be connected to the lifting member 112, for example using a pin as illustrated in FIG. 15.

**[00101]**The central member 1500 is configured in one exemplary embodiment such that as the lifting member 112 is raised relative to the bottom portion 1501, the dog 1530 rotates outwardly relative to the bottom portion 1501. The dog leg of the dog 1530 may be configured to limit or restrict movement of the dog 1530 in a direction opposite to the outward direction (e.g., based on a locking position, an incremental position, or the like). In one embodiment, the dog 1530 is configured with a release such that, based at least in part upon either manual or automated input, the dog 1530 is capable of releasing so as to allow the lifting member 112 to lower towards to the bottom portion 1501. The dog 1530 may be variously configured at least in part upon a desired or predetermined amount of weight or force received in a direction towards to the bottom portion 1501 to cause the dog 1530 to release the dog leg and permit the lifting member 112 to lower. For example, the dog 1530 may be configured to release if a weight greater than that of the lifting member 112 is received at the dog 1530, may be configured to release if the weight received at the dog 1530 is greater than 25 pounds, 50 pounds, 75 pounds, 100 pounds, or any other dynamically determined or predetermined criteria.

**[00102]**The central member 1500 may further comprise at least one tab 1520. The tab 1520 may comprise at least one opening 1525. The opening 1525 in one exemplary embodiment is configured to correspond with a pin configured to be received through the opening 1525. Each tab 1520 and opening 1525 is configured to correspond with at least one tab or opening of the lifting member 112 such that the central member 1500 and lifting member 112 are capable of being connected to one another via the pin.

**[00103]**The central member 1500 may further comprise at least one mounting point 1550. The central member 1500 may be attached to a surface using any one of at least one bolt, at least one hook and loop fastener, an adhesive material (e.g., any double sided tape, a tape such as 3M™ VHB™, etc.), or any other means of attachment, either alone or in combination, received via the at least one mounting point 1550. Furthermore, the means of attaching the central member 1500 to a surface may be located upon at least one surface of the central member 1500, a surface upon which it is intended to be mounted, or any combination thereof. In one exemplary embodiment, the central member 1500 may comprise at least one opening at the bottom portion 1501 which may be used to mount the central member to a mounting location by placing a bolt, screw, nail, tape, or other affixing element into or through the at least one opening and into or onto the surface upon which the central member 1500 is to be mounted. Optionally,

the at least one opening may be provided by means of a mounting bracket configured to be placed between the central member 1500 and mounting surface during installation.

**[00104]** FIG. 16 illustrates a partial bottom perspective view of a central member 1600 in accordance with an exemplary embodiment. Central member 1600 comprises a bottom portion 1601 and a lifting member 1612. In the embodiment illustrated by FIG. 16, the bottom portion 1601 may be equivalent to the previously described bottom portion 1501 and the lifting member 1612 may be equivalent to the previously described lifting member 112. The central member 1600 may comprise an adjustment member 1615 configured to connect the bottom portion 1601 and lifting member 1612. The adjustment member 1615 may be configured to pass through one or more apertures 1617 of the bottom portion 1601. At least a portion of the adjustment member 1615 may be configured to similarly pass through one or more apertures of the lifting member 1612 (e.g., in the manner illustrated at FIG. 18).

**[00105]** The central member 1600 may include at least one dog 1630 similar to that described above with reference to dog 1530. The lifting member 1612 may comprise at least one opening 1614. The opening 1614 may be configured to receive one or more pins configured to pass through at least a portion of the at least one opening 1614. In one exemplary embodiment, the lifting member 1612 may be configured to connect to one or more hinges to interconnect the lifting member 1612 and bottom portion 1601 of the central member 1600 (e.g., in the manner illustrated by FIG. 19). The central member 1600 may comprise at least one stop member 1620 located at an end thereof. In various embodiments, the stop member 1620 may function as previously described with reference to stop member 114.

**[00106]** FIG. 17 illustrates a zoomed view of a partial internal view of a central member 1700 according to an exemplary embodiment. The central member 1700 comprises a lifting member (e.g., lifting member 112) having an adjustment member 1715 configured in the manner previously described (e.g., with reference to adjustment members 1515, 1615). The central member 1700 may include one or more contact terminals 1517 passing at least partially through an adjustment member 1715. Each contact terminal 1517 may have a contact surface 1730 configured to be placed in contact with a conductive contact surface 1710 located at the lifting member 112. Each conductive contact surface 1710 may further comprise at least one conductive path, for example connecting the conductive contact surface with a control circuit, such as a printed circuit board associated with the locking apparatus (e.g., control circuit 450). One or more conductive paths may be configured to be shared between a plurality of conductive terminal contacts in one embodiment.

**[00107]** In operation, the control circuit may be configured to detect a force received by the locking apparatus by detecting a contact status between one or more contact terminals 1517 and one or more conductive contact surfaces 1710. For example, in one embodiment the control circuit may be configured to detect a disconnected status between a contact terminal 1517 and conductive contact surface 1710. Based at least in part upon the detected disconnected status, the control circuit may determine that an attempted entry has occurred and may contact at least one of a user, a homeowner, a landlord, a renter,

a police representative, a security company, or any other entity having an interest in an attempted entry while the locking apparatus is maintained in a locked state. The lifting member 112 may be configured with one or more receiving portions 1720, each receiving portion being configured to receive at least a portion of a contact terminal 1517 corresponding to an adjustment member 1715.

**[00108]** FIG. 18 illustrates a partial top elevational view of a central member 1800 according to an exemplary embodiment. The central member 1800 includes at least a lifting member 1812 connected to a bottom portion (e.g., bottom portion 1501) via the at least one passage 1830 formed on the lifting member 1812. At least one shaft 1835 is configured to pass through the passage 1830 and at least one tab 1520 of the bottom portion. In one exemplary embodiment, the lifting member 1812 and the bottom portion (e.g., bottom portion 1501) are connected via a hinge created via the shaft 1835 passing through the at least one passage 1830 of the lifting member 1812 and the at least one tab 1520 of the bottom portion.

**[00109]** The central member 1800 comprises at least one adjustment member 1815. The adjustment member 1815 may be connected to the bottom portion (e.g., bottom portion 1501) in the manner previously described. The adjustment member 1815 may further be connected to the lifting member 1812 via one or more apertures 1860. For example, the adjustment member 1815 may be wound through a plurality of apertures 1860 located at one or more surfaces of the lifting member 1812, as illustrated in the embodiment provided in FIG. 18.

**[00110]** The adjustment member 1815 may include one or more contact terminals 1817. Each contact terminal 1817 is configured to connect to at least a portion of the central member 1800. For example, one or more contact terminal 1817 may be configured to connect to a corresponding pin located at a lifting member 1812 associated with the central member 1800. The adjustment member 1815 and central member 1800 are configured in one exemplary embodiment such that at least a portion of the adjustment member 1815 is wound or wrapped around a portion of a of the bottom portion (e.g., bottom portion 1501). For example, as illustrated in FIG. 15, the adjustment member 1515 may be wound through one or more apertures 1519 in a portion of the central member 1500. The adjustment member 1815 is configured to connect to the lifting member 1812 at two contact terminals 1817 while also being looped through one or more apertures 1519 in the exemplary embodiment illustrated by FIG. 15. By doing so, the adjustment member is placed in tension and may absorb and translate forces received at one or more portions of the central member 1800.

**[00111]** The central member 1800 may comprise at least one resilience member 1820 associated with the adjustment member 1815. In one embodiment, each resilience member 1820 comprises an element configured to receive, transmit, or receive and transmit one or more forces applied to the adjustment member 1815. Each resilience member 1820 is configured to connect to at least one surface of the lifting member 1812 and to translate one or more forces through the resilience member 1820.

[00112] By incorporating a flexible adjustment member 1815 with the resilience members 1820, implementations consistent with the present disclosure are capable of manipulating a contact surface angle of the lifting member 1812 relative to an object whose movement is intended to be impeded or restricted (such as a door, window, etc.). For example, an opening door maintains a circular path in an opening direction. The present disclosure provides a locking apparatus contact surface capable of adjusting to maintain contact with a door through at least a portion of a door opening path based on at least one of flexibility of the adjustment member 1815 and at least one resilience member 1820. Thus, whereas a non-adjustable contact surface provides a reduced contact surface and thus increased centralized force on both the door and the locking apparatus at the reduced contact surface, the present disclosure permits a more evenly-distributed force across the lifting member, thereby reducing negative effects of focused energy on both the door and the locking apparatus. In embodiments where the resilience member 1820 is a spring, the spring's motion permits rotation of the lifting member 1812 such that the entire front (contact) edge of the lifting member 1812 may be placed in contact with a contact surface of the door in order to more efficiently transfer energy to protect the door. The adjustment member 1815 may be configured both to manipulate a position of the lifting member 1812 and to focus energy received from an object when the locking apparatus is operating in a locked position, similar to a spring function. The spring motion also permits rotation of the lifting member 1812 such that the entire front edge of the lifting member 1812 may be placed in contact with a contact surface of the object in order to more efficiently transfer energy to protect the object.

[00113] In various exemplary embodiments, the lifting member 1812 may be configured to rotate without using the at least one resilience member 1820. For example, the lifting member 1812 may be connected to the central member 1800 via the adjustment member 1815 alone. The adjustment member 1815 may take the form of an adjustment member 1515, as previously described herein, and the adjustment member 1815 may be configured to provide both energy absorption and tilt or rotation of the lifting member 1812 in a manner at least similar to that previously described herein.

[00114] The central member 1800 may include a selector 1870. In one exemplary embodiment, the selector 1870 comprises an opening through a portion of the lifting member 1812. The selector 1870 may comprise a toggle 1875. The toggle 1875 may take the form of a moveable portion configured to move within the opening of the selector 1870. In one exemplary embodiment, the toggle 1875 is configured to correspond to manual locking mode criteria. For example, the toggle 1875 may be defined with two positions relative to the selector 1870, one position corresponding to manual operation, and one position corresponding to automated operation. The position of the toggle 1875 is configured to be set either at the time of manufacturing, or may be dynamically manipulated (e.g., by an installer or purchaser) after the time of manufacturing. In one exemplary manner of operation, a user of a locking apparatus consistent with the embodiment illustrated at FIG. 18 is capable of causing the lifting member

1812 to elevate to a locked position using a lifting selector associated with a pedal as described, for example, with reference to FIG. 19.

**[00115]** When the toggle 1875 is in a manual operation mode position and an input is received from a user at the pedal of the locking apparatus, the lifting member 1812 may be caused to elevate to a locked position. A manual unlocking mechanism may be variously implemented, but in one embodiment may be performed by providing a downward force, pressure, or weight upon at least a portion of the locking apparatus (e.g., by stepping downward upon an elevated lifting member 1812). Optionally or alternatively, a locking apparatus consistent with the present disclosure may be transitioned from a locked state to an unlocked state by providing an input to the locking apparatus (e.g., by depressing a pedal associated with the locking apparatus). The exemplary pedal may comprise a single pedal for both locking and unlocking the locking apparatus, or a plurality of pedals may be provided, for example including one lifting pedal and one lowering pedal, without departing from the spirit and the scope of the present disclosure.

**[00116]** Fig. 19 illustrates a raised perspective view of a portion of an internal view of a central member 1900 according to an exemplary embodiment. The central member 1900 includes at least a bottom portion 1901 and lifting member 1912. Each of the bottom portion 1901 and lifting member 1912 may take the form of the previously described bottom portion and lifting member without departing from the spirit and the scope of the present disclosure.

**[00117]** The central member 1912 may further comprise a hinge 1920. In one exemplary embodiment, the hinge 1920 may comprise a lower portion 1922 and an upper portion 1924 being connected via at least one pin 1926. Alternatively, the hinge 1920 may take the form of a unibody hinge, without the need for the pin 1926. The upper portion 1924 of hinge 1920 may be configured to connect to the lifting member 1912 via at least one pin 1916, with at least a portion of at least one pin 1916 being configured to be received at one or more apertures 1914 at the lifting member 1912. The lower portion 1922 of the hinge 1920 may be configured to connect to the bottom portion 1901 in one embodiment via at least one pin 1928. The at least one pin 1928 may be configured in one embodiment to pass through at least a portion of the bottom portion 1901 (e.g., through the at least one opening 1525 of tab 1520 as previously described).

**[00118]** FIG. 20 illustrates a top perspective view of an exemplary embodiment of a locking apparatus 2000. The locking apparatus may comprise one or more of a central member 2010, an outer housing 2020, and a power housing 2030. The outer housing may comprise a pedal 2025 for enabling manual operation (e.g., as previously described herein with reference to the push/pull type mechanism and foot pedal 54 and associated structure described in Provisional Patent Application 62/038,393 (as incorporated by reference herein in its entirety)).

**[00119]** FIG. 21 illustrates an exemplary embodiment of a locking apparatus showing a perspective view of a partial internal view of a central member 2010 and outer housing 2020 in accordance with the

present disclosure. The pedal 2025 may be configured to contact a manual operation engager 2027. In one exemplary embodiment, the manual operation engager 2027 comprises a level configured to adjust a physical position based upon the presence or absence of contact with a surface of the pedal 2025. For example, the manual operation engager 2027 may be positioned relative to a pivot and the pedal 2025, where contact with the pedal 2025 causes at least a portion of the manual operating engager 2027 at an end opposite to the pedal 2025 to raise or lower within a portion of the central member 2010. If the toggle 1875 within the selector 1870 restricts movement of the manual operating engager 2027, manual operation may be prevented. Manual operation may be enabled when a position of the toggle 1875 corresponds to a manual operation mode, and movement of the manual operating engager 2027 when the pedal 2025 is manipulated by a user may cause the lifting member 112 to raise or lower as previously described herein (e.g., based at least in part upon contact between the manual operating engager 2027 and a surface of the lifting member 112).

**[00120]** FIG. 22 illustrates a flowchart of an exemplary embodiment of a process for performing a detection process for a locking apparatus according to aspects of the present disclosure. The process 2200 begins at an operation 2202 where the control system of the locking apparatus is activated. In various embodiments, the control system may be performed, either in whole or in part, by at least one component of the control circuit 450. The control system may be activated by a user, either manually at the locking apparatus or remotely from the locking apparatus. Additionally or alternatively, at least one operation of the control system may be activated automatically or otherwise based at least in part upon one or more operations not associated with a user.

**[00121]** The process continues to an operation 2204 where a status of one or more detection devices is determined. The one or more detection devices may include an accelerometer, an electromechanical switch, or any other sensing element configured to measure and/or to determine a status of movement, intrusion, unusual activity, a notification event, or any other form of detectable or determinable information relating to a locking apparatus described herein. The control circuit 450 may be configured to receive a plurality of inputs from one or more detection devices. In one exemplary embodiment, the control circuit 450 is configured to receive at least one input corresponding to an accelerometer and at least one input from an electromechanical switch, although more or fewer detection devices and/or inputs may be used without departing from the spirit and scope of the present disclosure.

**[00122]** The process may continue to an operation 2206 where it is determined whether an impact, contact, or motion (e.g., an event) is detected by via at least one detection device, such as an accelerometer, electromechanical switch, motion sensor, glass break detector, or any other form of detection device. Impact, contact, or motion may be determined, for example using the control circuit 450, by detecting a break of contact of the electromechanical switch, an observed value of the accelerometer, set of data or detection information from one or more detection devices, or combination thereof. If no impact, contact, or motion is detected at operation 2206 the process may return to operation

2204. If impact, contact, or motion is detected at operation 2206, the process may continue by selectively performing an impact, contact, or motion verification operation. The verification operation may include comparing one or more values measured by or determinable from information of one or more detection devices. In various embodiments, one or more thresholds, values, or ranges may be associated with one or more detection devices. For example, a value measured by or determinable from information associated with an accelerometer may be compared to a value measured by or determinable from information associated with an electromechanical switch. Each of the accelerometer and the electromechanical switch may selectively have one or more data values and/or ranges of values associated with at least one of impact, contact, or motion. One or more data values and/or ranges of values may be compared to one another to verify an impact, contact, or motion associated with a locking device.

**[00123]** Systems and methods consistent with the present disclosure may include the ability for the control circuit 450, a back-end server, and/or a user device communicatively coupleable to the locking apparatus 100 to comparatively and/or iteratively determine an alert criteria associated with an impact, contact, or motion associated with a locking apparatus 100. For example, if a measured value at an accelerometer indicates an impact, contact, or motion event, one or more values associated with another detection device may be observed or obtained to determine if a similar impact, contact, or motion event was measured or can be determined (e.g., using one or more values or ranges of values associated with one or more detection devices). One or more settings or weights may be applied to measured or observed values from the detection devices. For example, using a user interface provided by an electronic device of a user, the user may select one or more event settings. Event settings may relate to event alert sensitivity in various embodiments. For example, a user may adjust, either statically or dynamically, a detection sensitivity setting for one or more detection devices, an alert criteria such as event verification via multiple detection devices, a sequence of performing event verification, or any other operational or functional setting associated with the locking apparatus 100, the detection devices, user settings, and/or combination thereof.

**[00124]** The process may continue at an operation 2210 where an event alert is optionally generated. The event alert may be selectively determined, at least in part, according to one or more event settings. One or more event settings may include a default setting without requiring user intervention. At least one event alert may be selectively transmitted from the control circuit 450 at operation 2212, for example via wireless communication of the transceiver 455 such as by Wi-Fi, Bluetooth, Z-wave, or any other wireless communication protocol and/or network. At least one event alert may additionally or alternatively be transmitted via wired communications from the transceiver 455. In various embodiments, a user associated with a locking apparatus 100 may receive at least one event alert or notification at an electronic device associated with the user, such as a smart phone, computer, smart watch, or any other electronic device capable of receiving communications and conveying a message or

indication of a message to a user thereof. The process may then end or may selectively return to operation 2204.

**[00125]** FIG. 23 illustrates a partial top view of a block diagram of an exemplary embodiment of a locking apparatus according to aspects of the present disclosure. The system 2300 illustrated by FIG. 23 may include a locking apparatus 100 having a strap 1515 coupled between a strap coupler 2310 attached to a body of the locking apparatus 100 and a conductor 2320 coupled at an opposing end of the strap 1515. At least one section of the strap 1515 may be coupled to and/or capable of being placed in contact with at least a portion of the locking apparatus 100, for example at a lifting member and/or body thereof. An electromechanical switch 2330 may be removably coupleable with the conductor 2320. A gap G may be formed between the electromechanical switch 2330 and the conductor 2320 during operation of the locking apparatus 100, for example when an impact or force is received by the lifting member of the locking apparatus 100. A gap G may be associated with an open switch setting of the electromechanical switch 2330. When in a locked state, the electromechanical switch 2330 and the conductor 2320 may be coupled together to form a closed setting of the electromechanical switch 2330. One or more of the conductor 2320 and the electromechanical switch 2330 may be coupleable to the control circuit 450, for example via at least one bus 2340.

**[00126]** A locking apparatus 100 may include a body and a lifting member coupleable to the body, at least a portion of the lifting member may be configured to move relative to the body according to a command position relating to a locking status of the locking apparatus. The lifting member in an exemplary embodiment may include (i) a contact surface configured to restrict movement of an object, and (ii) an electromechanical switch, the lifting member configured to receive an external force. An accelerometer may be coupled to the body of the locking apparatus. The accelerometer may receive an indication of the external force received at the lifting member. The locking apparatus may further include a control circuit configured to determine a first indicia corresponding to the received external force at the lifting member and to determine a second indicia corresponding to the received indication of the external force by the accelerometer.

**[00127]** FIG. 24 illustrates a partial block diagram of an exemplary embodiment of a control circuit 450 according to aspects of the present disclosure. The control circuit 450 may include a microprocessor 2410, an accelerometer 2420, a storage 2430, a display unit 2440, and/or a transceiver 455. Although illustrated as being physically part of the control circuit 450 it should be appreciated that one or more components of the control circuit 450 of FIG. 24 may be physically and/or logically remote from the body of the control circuit 450. As used herein, the microprocessor 2410 may be, in whole or in part, a general-purpose processor, a digital signal processor (DSP), an application specific integrated circuit (ASIC), a field programmable gate array (FPGA) or other programmable logic device, discrete gate or transistor logic, discrete hardware components, or any combination thereof designed and programmed to perform or cause the performance of the functions described herein. A general-purpose processor can

be a microprocessor, but in the alternative, the processor can be a controller, microcontroller, or state machine, combinations of the same, or the like. A processor can also be implemented as a combination of computing devices, e.g., a combination of a DSP and a microprocessor, a plurality of microprocessors, one or more microprocessors in conjunction with a DSP core, or any other such configuration.

**[00128]**The accelerometer 2420 may be part of the control circuit 450 or may be otherwise communicatively coupleable to the control circuit 450. The accelerometer 2420 may be a capacitive Micro-Electro-Mechanical System (MEMS) type, a piezoresistive type, a piezoelectric style accelerometer, or any other device capable of detection motion or impact and capable of generating and/or providing a signal as output corresponding thereto. The accelerometer 2420 may be configured to detect motion of associated with the accelerometer 2420 and to generate at least one signal corresponding thereto. One or more output signals of the accelerometer 2420 may be provided to the control circuit 450 to enable operations described herein.

**[00129]**The storage 2430 may be configured as a volatile and/or non-volatile memory element configured to store at least one set of information used by or in association with the locking apparatus 100. This includes, for example, control logic, operating parameters, or any other set(s) of relevant data. The control circuit 450 may include or otherwise be coupleable to a display unit 2440. The display unit 2440 may be configured to visually convey at least one set of control and/or operating information, for example to a user of the locking apparatus 100 (e.g., regarding a status, event condition, etc.). The transceiver 455 of the locking apparatus 100 of FIG. 24 may be configured to operate in the manner previously described herein.

**[00130]**During operation, forced entry may be attempted which causes the strap 1515 of the locking apparatus 100 to flex along with the lifting member coupled thereto. The lifting member may be configured to flex along a contact surface thereof to meet an openable object placed in contact therewith through the attempted intrusion or other contact between the openable object and the contact surface of the lifting member. The locking apparatus 100 may be configured to detect forces associated therewith, including accelerometer-based, electromechanically, or a hybrid of multiple approaches. The locking apparatus 100 may be configured to send a notification to another system and/or directly to a user device using a communication link which could be, but is not limited to, hard wire signaling, Wi-Fi, Z-wave, Zigbee, Bluetooth, cellular, or any other wireless or wired method. In practice, the openable object may traverse a gap between the lifting member and the openable object to be placed in contact with the lifting member. The locking apparatus 100 may detect contact with the openable object at the lifting member and may determine an alert event, such as an attempted entry via the control circuit 450. The locking apparatus 100 may transmit a notification via a communication link to another system and/or user device relating to the alert event.

**[00131]**Using a communication channel, users may be allowed to set a device sensitivity setting remotely. This may place a setting relating to the accelerometer that varies the force required to trigger

an entry alert back into the system (e.g., a back-end system or user device). For example, a sensitivity setting may be set to "light force" so that any activity around a door triggers the notification, or it may be set it to "heavy force" which requires significant force to send the notification. Sensitivity settings may be of a fixed type and amount (e.g., light, medium, or heavy) or may be dynamically selectable, in whole or in part, using a slider or toggle.

**[00132]** Metal contacts such as the conductor 2320 and electromechanical switch 2330 may act as a normally closed electromechanical switch. When force is applied at the lifting member by virtue of contact with an openable object, the force is transferred to a woven (e.g., textile) strap 1515. The strap 1515 may tighten under the force and pull the metal plates apart thereby opening the switch. The control circuit 450 may be used to detect the now open switch which has changed state under the exerted force and thus created an electrical signal that represents the force. One or more control schemes may then be implemented in a manner consistent with the previous disclosure herein.

**[00133]** Further consistent with implementations of the present disclosure, a method is provided for detecting an alert status of a locking apparatus for an entry point. The method includes receiving an external force at a locking apparatus operating in a locked state and determining a first indicia corresponding to the received external force, separately receiving an indication of the external force at an accelerometer of the locking apparatus and determining a second indicia corresponding to the received indication of the external force, comparing the first indicia and the second indicia to determine an alert condition, and selectively performing at least one alert operation corresponding to the determined alert condition. The determining the first indicia corresponding to the received external force may include determining an amount of flex of a lifting member of a locking apparatus 100 caused by the external force. The external force may be a force of an openable object (e.g., a door) opening inwardly into an interior space securable by the locking apparatus 100. The first indicia may be determined according to a status of an electromechanical switch 2330 of the locking apparatus 100.

**[00134]** The comparing the first indicia and the second indicia may include determining a sensitivity setting and applying the sensitivity setting to a result of the comparing the first indicia and the second indicia to determine the alert condition. An indication of the alert condition may be transmitted to an external device, such as a back-end server and/or user device. The transmitting the indication of the alert condition may include wirelessly transmitting the indication of the alert condition. The transmitting the indication of the alert condition to the external device may include wirelessly transmitting the indication of the alert condition to an electronic device associated with the locking apparatus.

**[00135]** According to aspects of the present disclosure, during operation an acceleration detection system of a locking apparatus 100 may use an accelerometer 2420 (e.g., as multi-axis accelerometer or other form of accelerometer or detection element) to monitor an environment for movement and/or force in any direction. The accelerometer 2420 may be configured in a manner as to receive or otherwise measure one or more forces exerted on the locking apparatus 100, for example by translating the motion and/or

acceleration in the accelerometer 2420. At least a portion of the accelerometer 2420 may be mounted to the locking apparatus 100 in various embodiments to permit such measurement by the accelerometer 2420. At least one selectable threshold may be implemented in association with measured motion and/or acceleration. For example, the accelerometer 2420 may be associated with a selectable threshold ranging from small forces up to significant blows to the locking apparatus 100. At least one selectable threshold may be set by an end user of the locking apparatus 100 (e.g., using an app or other interface or portal associated with the end user and/or locking apparatus 100). Additionally or alternatively, permitting the use of a selectable threshold value may permit acceleration and/or force detection to be tuned at any time, to be calibrate to a door, an installation, and/or other environmental condition(s) associated with a location of a locking apparatus 100.

**[00136]** When an accelerometer 2420 detects a force, the force magnitude of the detected force may be compared against an associated selectable threshold value. If the force measurement is larger than the configured threshold, then a signal may be sent from the accelerometer 2420 to the control circuit 450, for example via an interrupt over a communication bus. The control circuit 450 may handle the event (e.g., immediately upon receipt) and may optionally filter the alert before forwarding the alert to an alert system. If the locking apparatus 100 is in an unlocked position, the control circuit 450 may be configured to filter and optionally ignore the force event trigger from the accelerometer 2420. This condition may be desired, as the unlocked position implies no need for an alert. However, logic such as general motion detection may be implemented consistent with the present disclosure, for example by sending one or more alerts even when the lock is in an unlocked position, which may indicate an interaction worth tracking in some manner.

**[00137]** If, however, the lock is in the locked position and the accelerometer 2420 sends a force event trigger, the system may enter a short wait state (such as a delay). The wait state timing may be, for example, a fraction of a second, low single digit seconds, or any other applicable timing without departing from the spirit and scope of the present disclosure. Once the wait time has expired, the control circuit 450 may check the lock state using a sensor such as an accelerometer or other mechanism that can detect a lock state (such as locked or unlocked). In various exemplary embodiments, a Hall effect sensor (e.g., a permanent magnet) configured to move with a locking mechanism of the locking apparatus 100 and converts the lock state to a digital signal that the control circuit 450 can query or otherwise obtain information regarding at any time.

**[00138]** If the control circuit 450 queries the lock state and the locking apparatus 100 is operating in the unlocked position, the control circuit 450 may ignore the event, as it was likely triggered by a manual unlock by the user (e.g., using a foot pedal). This logic may be used to differentiate motion events stemming from manual unlocking from those are uncharacterized and thus could be a legitimate motion alert. If, however, the control circuit 450 queries the lock state and the locking apparatus 100 remains in the locked position, the control circuit 450 may register the event with a downstream system to process

an alarm condition or alert. If a detected force or motion generates a legitimate alarm condition, an alert message may be sent via wired or wireless protocol to a device that can further process the event (such as, for example, by generating audible and/or visual alerts, sending alerts to one or more mobile devices, notifying cloud-connected services, and/or alerting other panels, readouts, or systems, or the like)

**[00139]**The previous detailed description has been provided for the purposes of illustration and description. Thus, although there have been described particular embodiments of the present invention of new and useful locking apparatuses, systems, and methods of providing access control. it is not intended that such references be construed as limitations upon the scope of this invention.

**CLAIMS**

What is claimed is:

1. A method of detecting an alert status of a locking apparatus for an entry point, comprising:  
receiving an external force at a locking apparatus operating in a locked state and determining a first indicia corresponding to the received external force;  
separately receiving an indication of the external force at an accelerometer of the locking apparatus and determining a second indicia corresponding to the received indication of the external force;  
comparing the first indicia and the second indicia to determine an alert condition; and  
selectively performing at least one alert operation corresponding to the determined alert condition.
2. The method of Claim 1, wherein the determining the first indicia corresponding to the received external force comprises determining an amount of flex of a lifting member of a locking apparatus caused by the external force.
3. The method of Claim 2, wherein the external force is a force of a door opening inwardly into an interior space securable by the locking apparatus.
4. The method of Claim 1, wherein the first indicia is determined according to a status of an electromechanical switch of the locking apparatus.
5. The method of Claim 1, wherein the comparing the first indicia and the second indicia includes determining a sensitivity setting and applying the sensitivity setting to a result of the comparing the first indicia and the second indicia to determine the alert condition.
6. The method of Claim 1, wherein the alert condition comprises transmitting an indication of the alert condition to an external device.
7. The method of Claim 6, wherein the transmitting the indication of the alert condition comprises wirelessly transmitting the indication of the alert condition.
8. The method of Claim 6, wherein the transmitting the indication of the alert condition to the external device comprises wirelessly transmitting the indication of the alert condition to an electronic device associated with the locking apparatus.
9. A locking apparatus, comprising:  
a body;  
a lifting member coupleable to the body, at least a portion of the lifting member configured to move relative to the body according to a command position relating to a locking status, the lifting member comprising (i) a contact surface configured to restrict movement of an object, and (ii) an electromechanical switch, the lifting member configured to receive an external force;  
an accelerometer coupled to the body, the accelerometer configured to receive an indication of the external force received at the lifting member; and

a control circuit configured to determine a first indicia corresponding to the received external force at the lifting member and to determine a second indicia corresponding to the received indication of the external force by the accelerometer.

10. The locking apparatus of Claim 9, wherein the control circuit is further configured to compare the first indicia and the second indicia to determine an alert condition; and to selectively perform at least one alert operation corresponding to the determined alert condition.

11. The locking apparatus of Claim 10, wherein the control circuit is configured such that the comparing the first indicia and the second indicia includes determining a sensitivity setting and applying the sensitivity setting to a result of the comparing the first indicia and the second indicia to determine the alert condition.

12. The locking apparatus of Claim 9, wherein the control circuit is configured such that determining the first indicia corresponding to the received external force comprises determining an amount of flex of the lifting member caused by the external force.

13. The locking apparatus of Claim 12, wherein the locking apparatus is configured to restrict movement of a door into an interior space securable by the locking apparatus, and wherein the external force is a force of the door opening inwardly into the interior space securable by the locking apparatus.

14. The locking apparatus of Claim 10, further comprising a transceiver, the control circuit configured to control the transceiver to communicate a representation of the determined alert condition.

15. The locking apparatus of Claim 14, wherein the control circuit is configured to cause the transceiver to wirelessly transmit the representation of the determined alert condition.

16. A method of controlling a locking apparatus, comprising:  
selecting a threshold value, the threshold value corresponding to a force value associated with the locking apparatus;  
detecting a force received at the locking apparatus;  
comparing the detected force to the selected threshold value;  
determining an alarm condition status based at least in part upon the comparison of the detected force to the selected threshold value; and  
selectively performing at least one alarm operation corresponding to the determined alarm condition status.

17. The method of Claim 16, wherein the determining the alarm condition status comprises determining a locking status of the locking apparatus.

18. The method of Claim 17, wherein the locking status of the locking apparatus is a locked status, and wherein the determining the alarm condition status comprises providing a time delay after determining that the locking apparatus is in the locked status.

19. The method of Claim 18, wherein the alarm condition status is determined to be a no alarm status when the locking apparatus is determined to be operating in an unlocked status after expiration of the time delay.

20. The method of Claim 18, wherein the alarm condition status is determined to be an active alarm status when the locking apparatus is determined to be operating in the locked status after expiration of the time delay, wherein a control circuit of the locking apparatus transmits at least one alarm status communication responsive to the active alarm status determination.

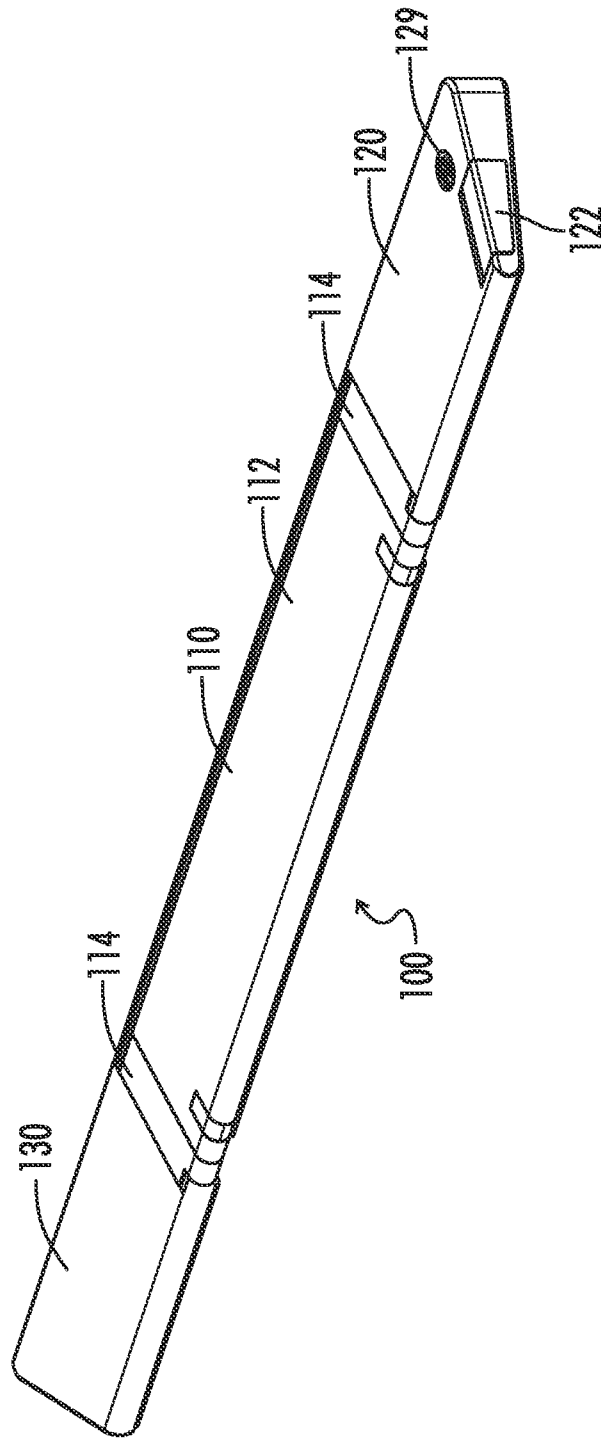
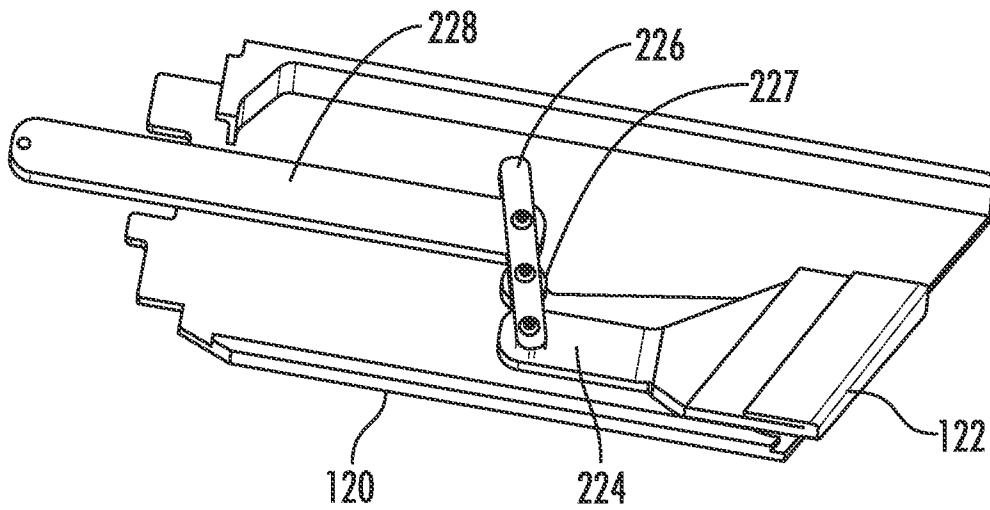
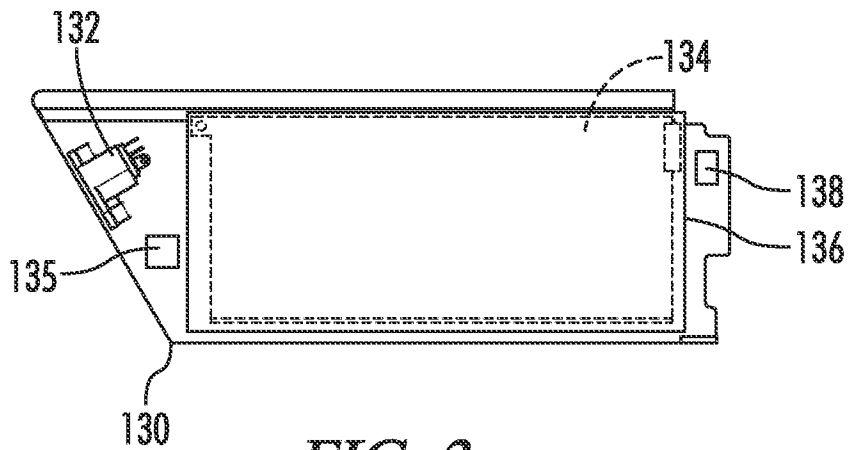


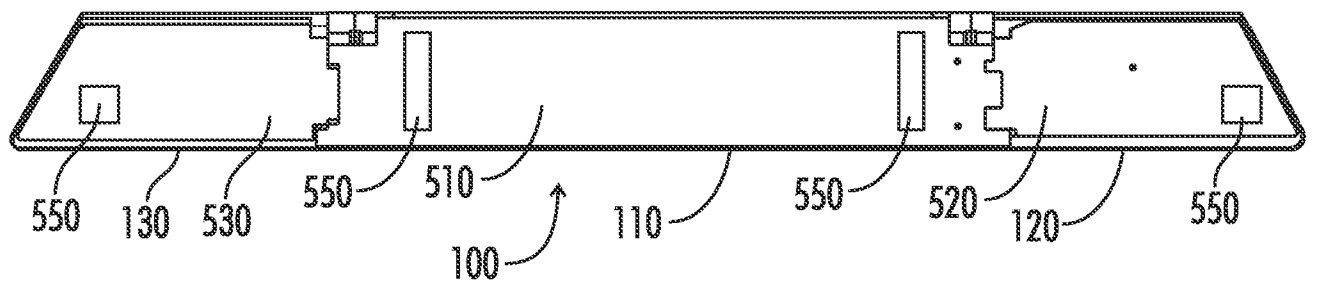
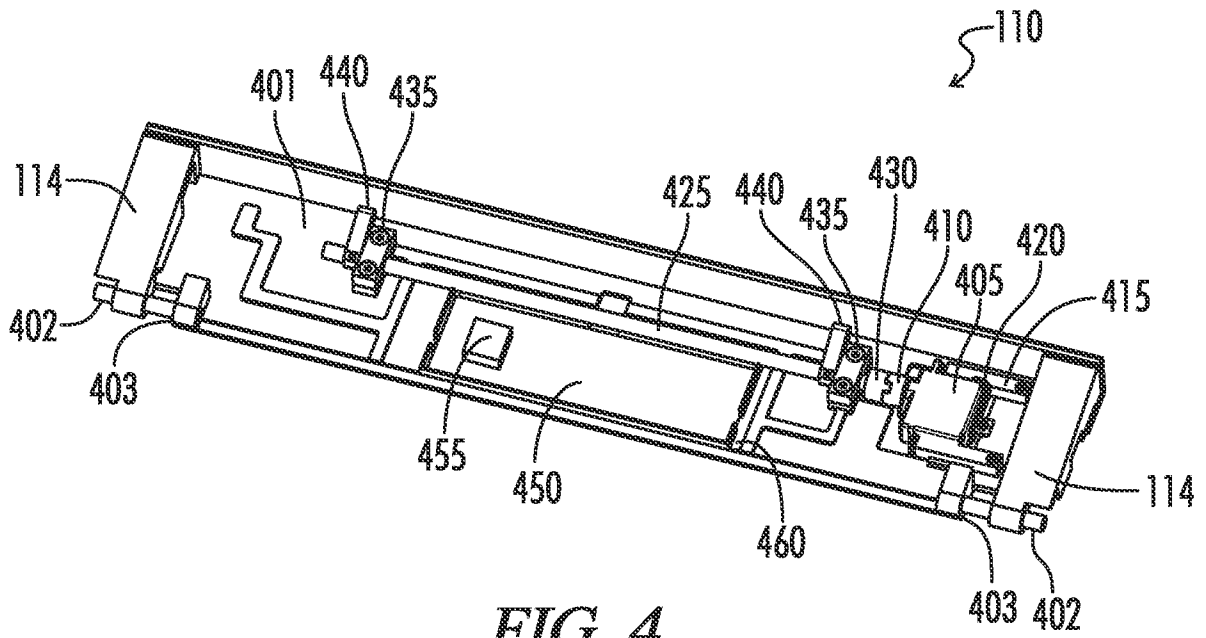
FIG. 1

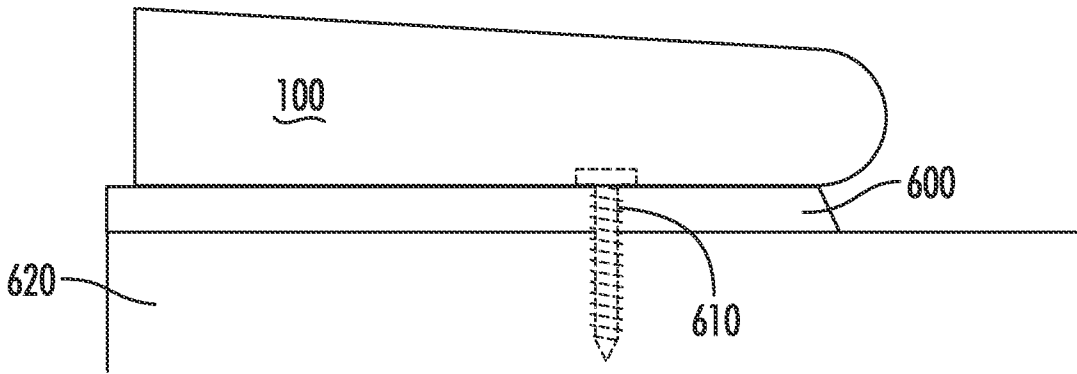


**FIG. 2**

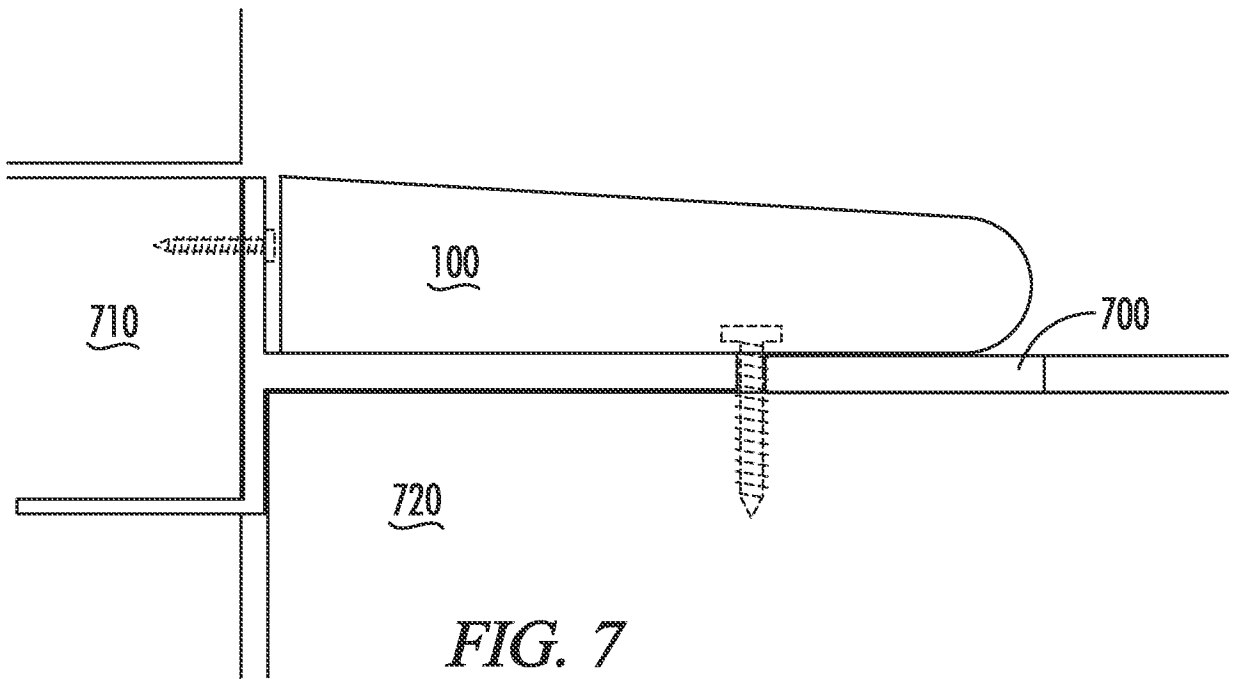


**FIG. 3**

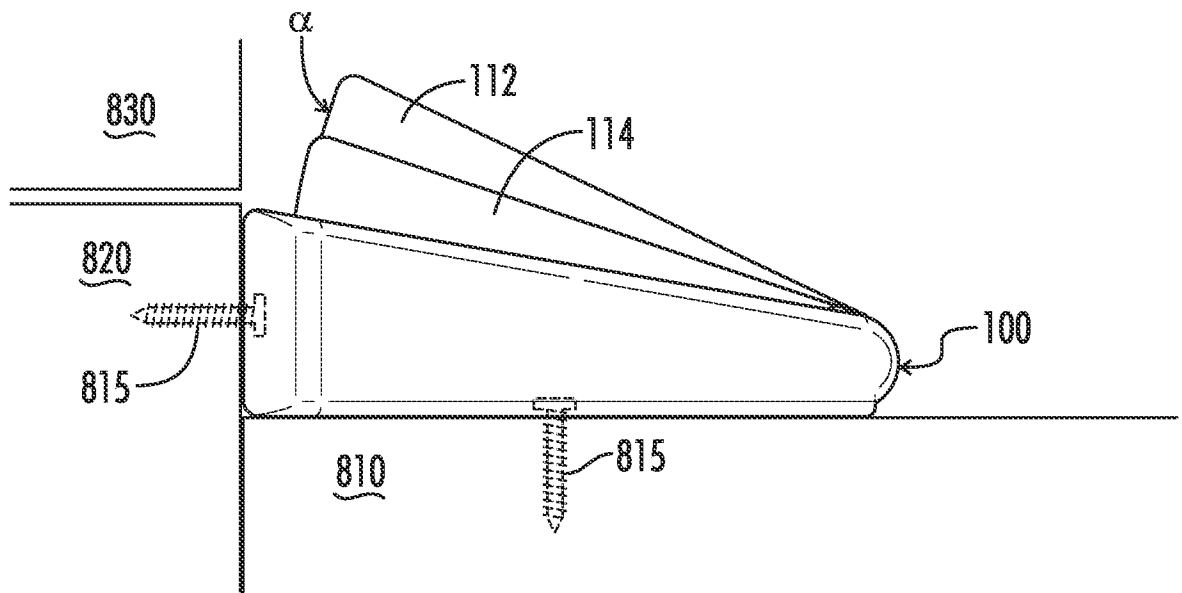




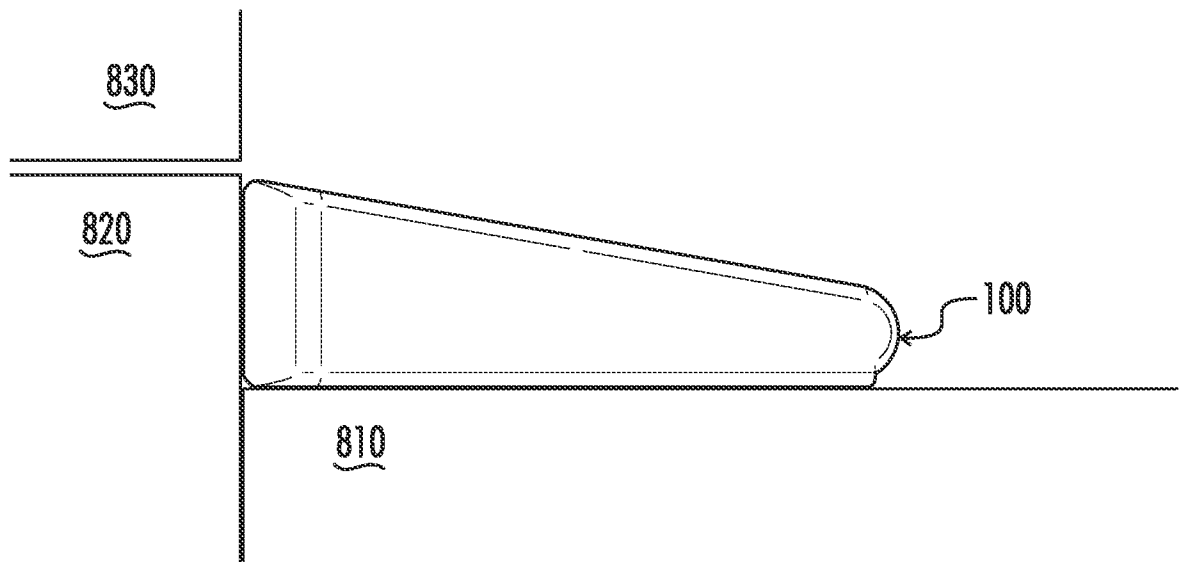
*FIG. 6*



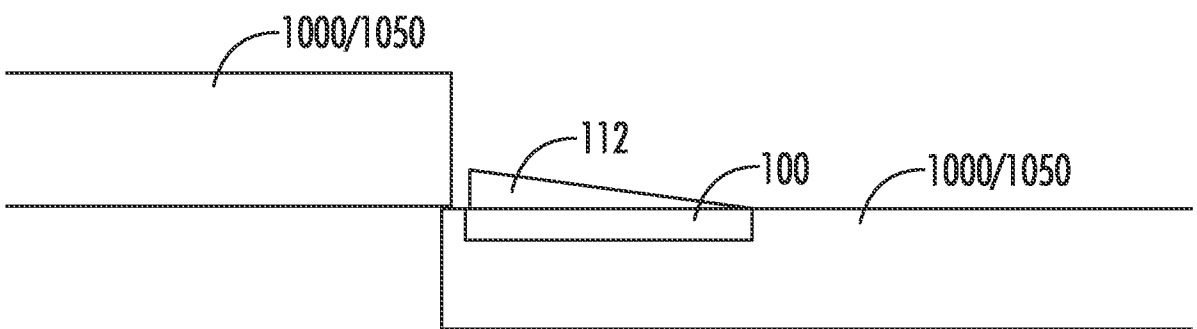
*FIG. 7*



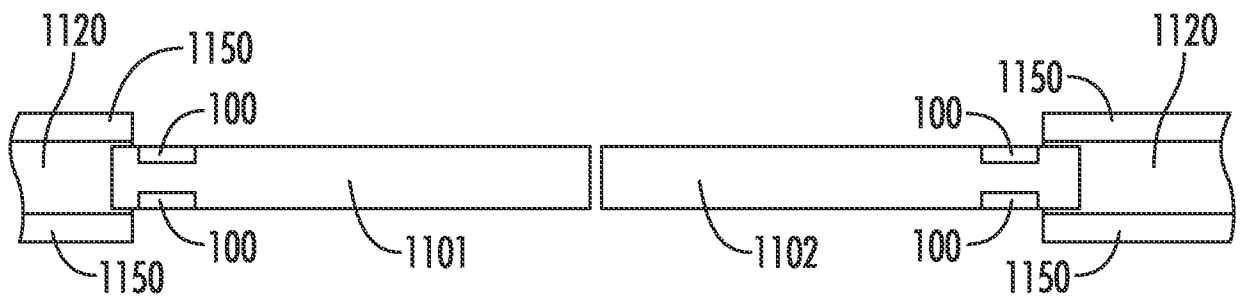
*FIG. 8*



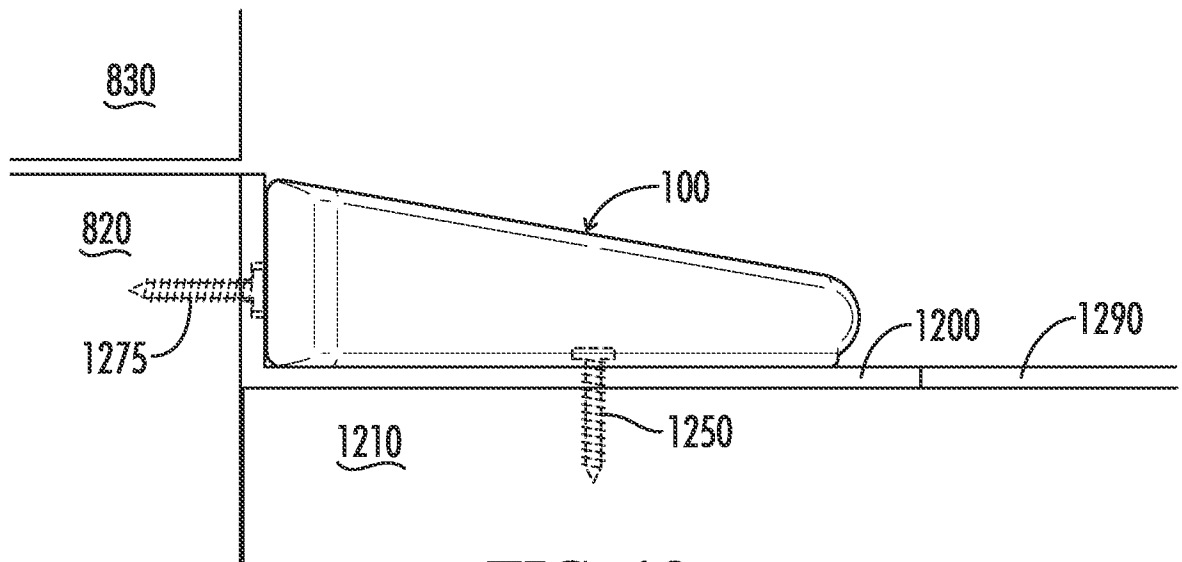
*FIG. 9*



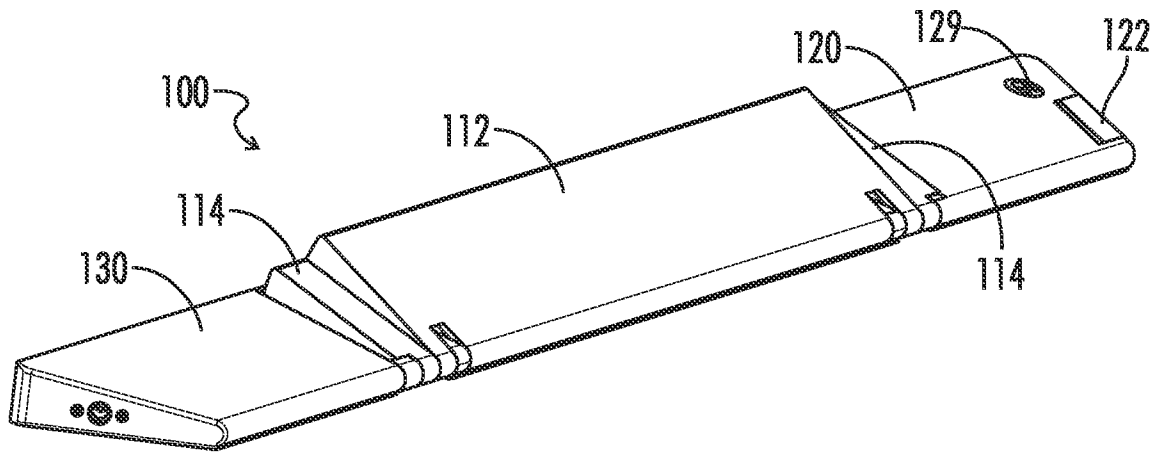
*FIG. 10*



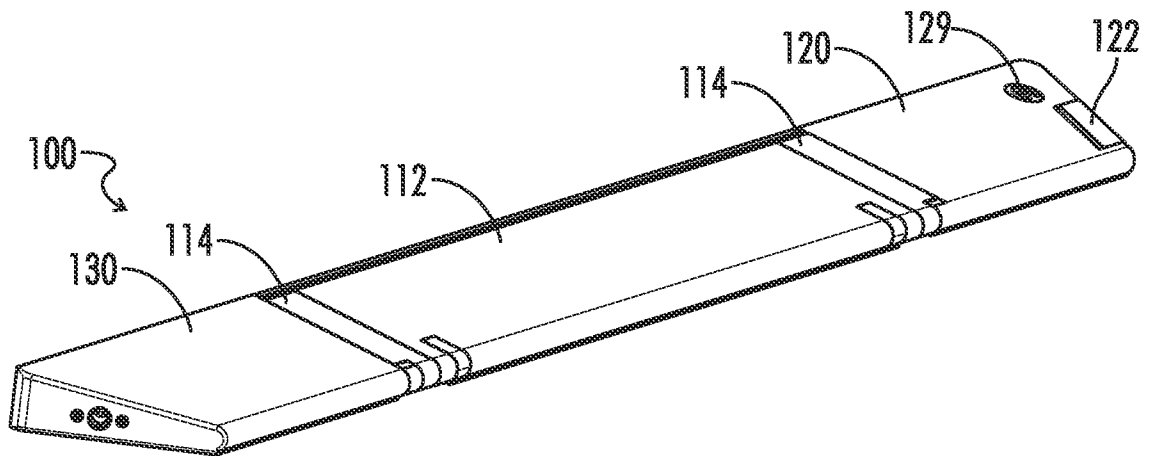
**FIG. 11**



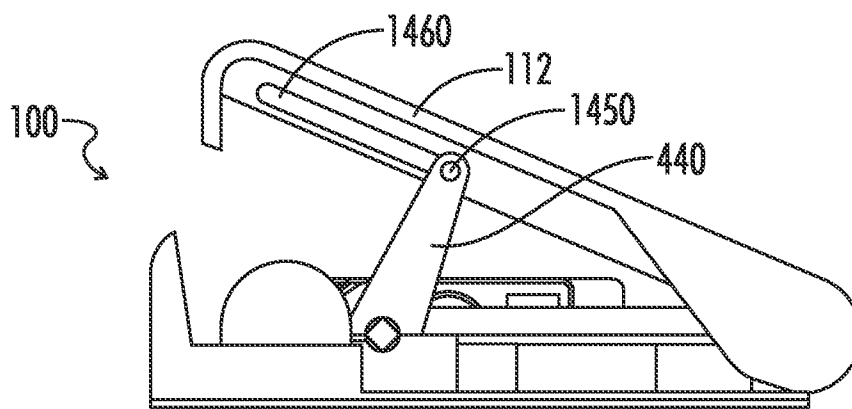
**FIG. 12**



**FIG. 13A**



**FIG. 13B**



**FIG. 14**

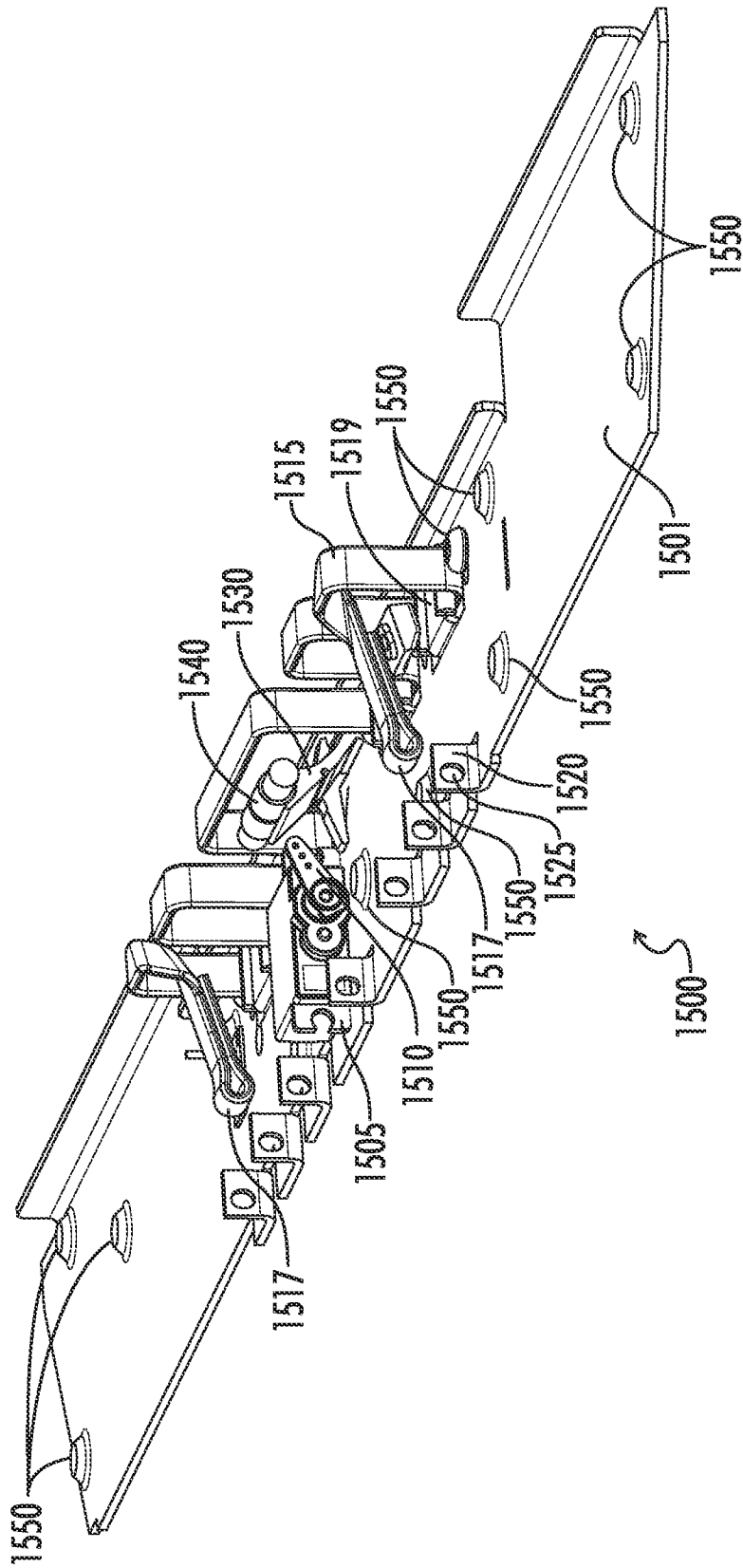


FIG. 15

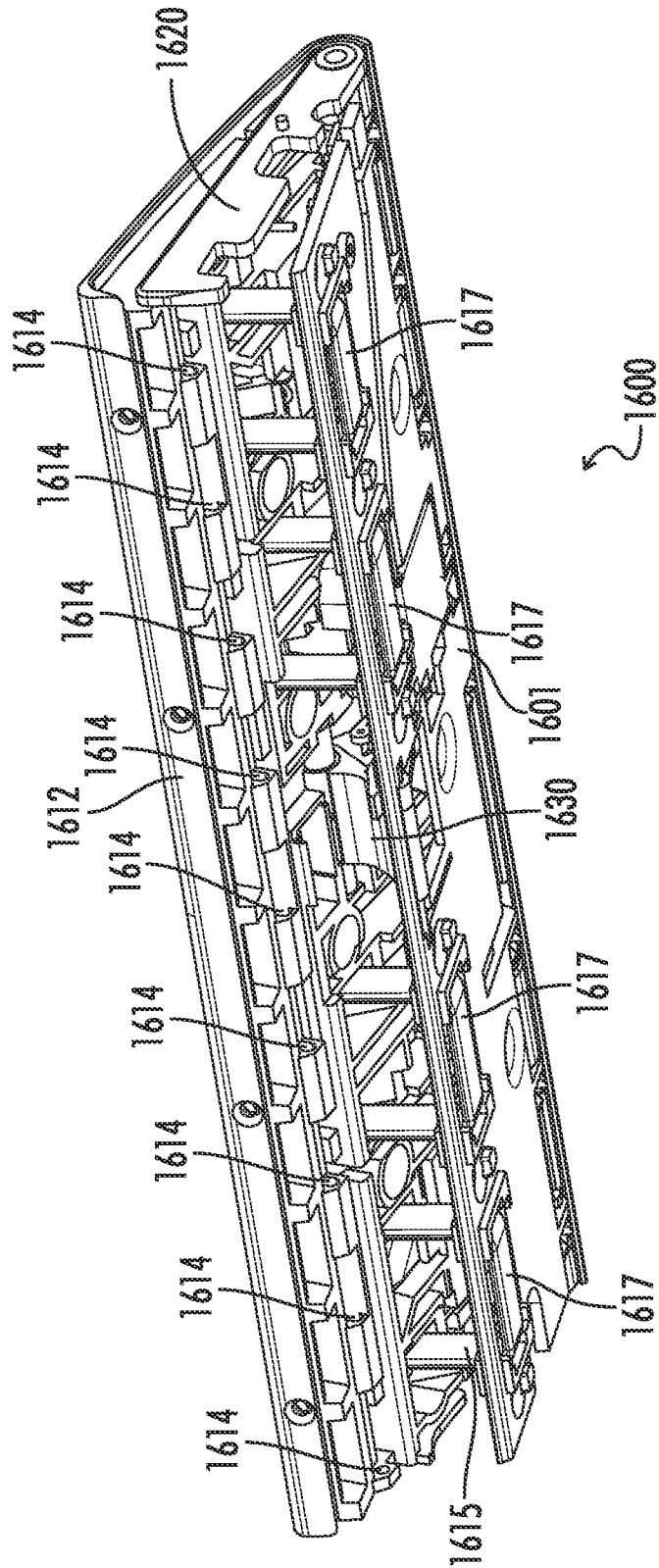
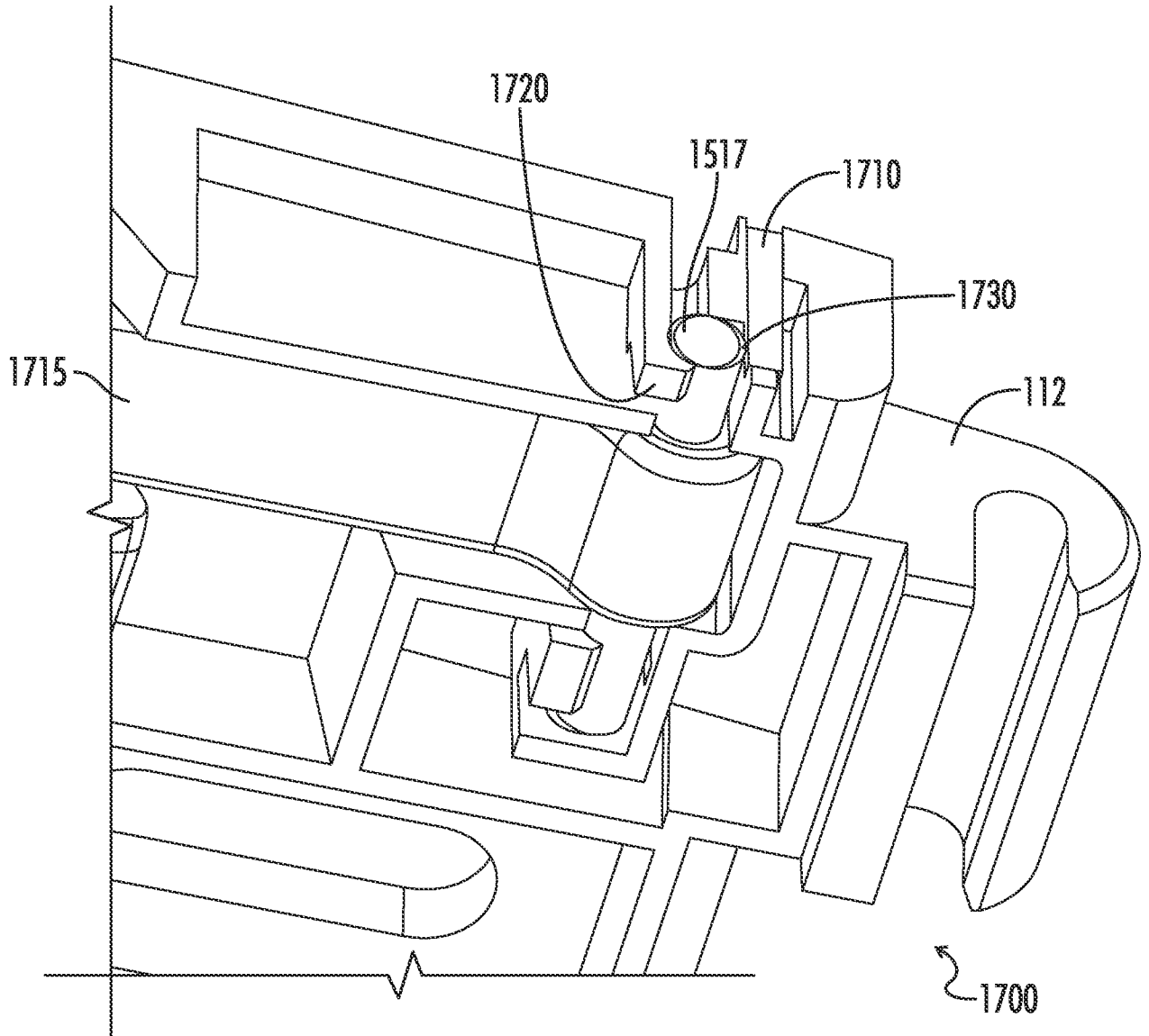


FIG. 16



**FIG. 17**

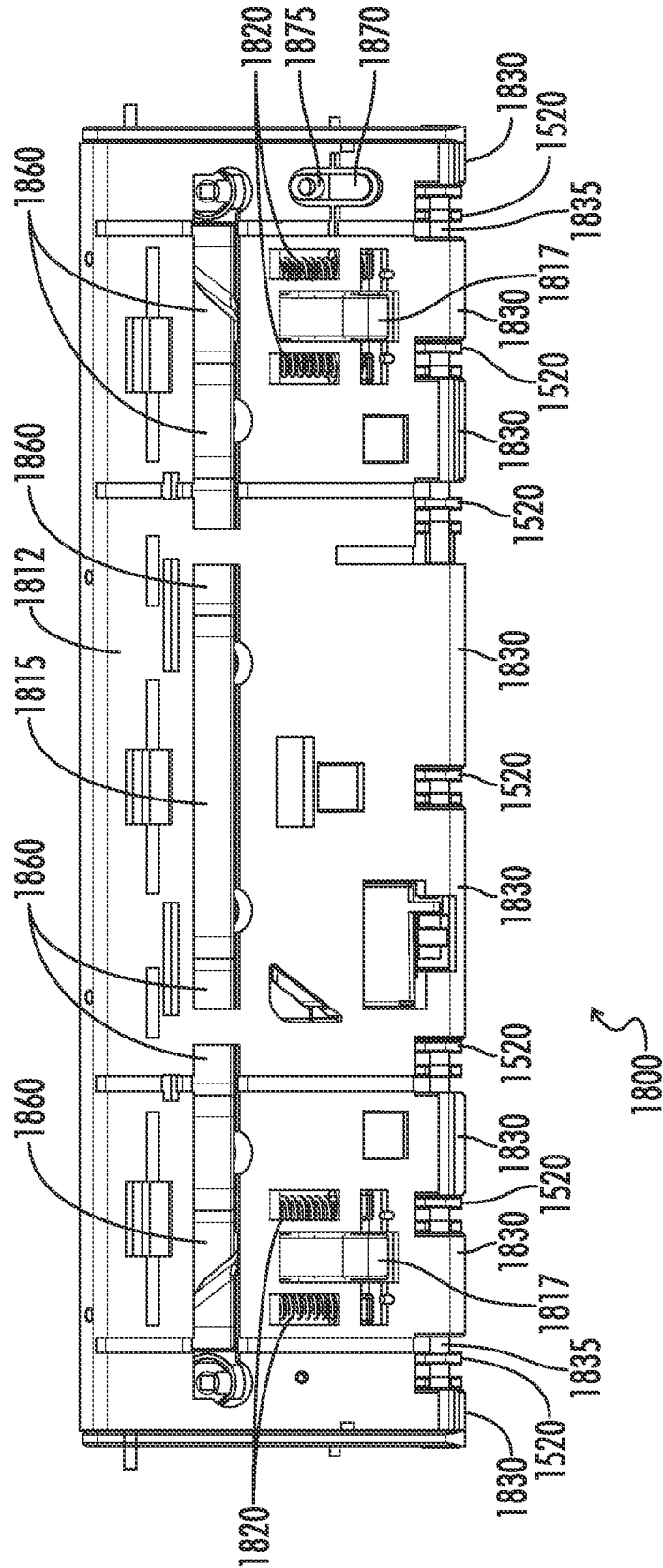
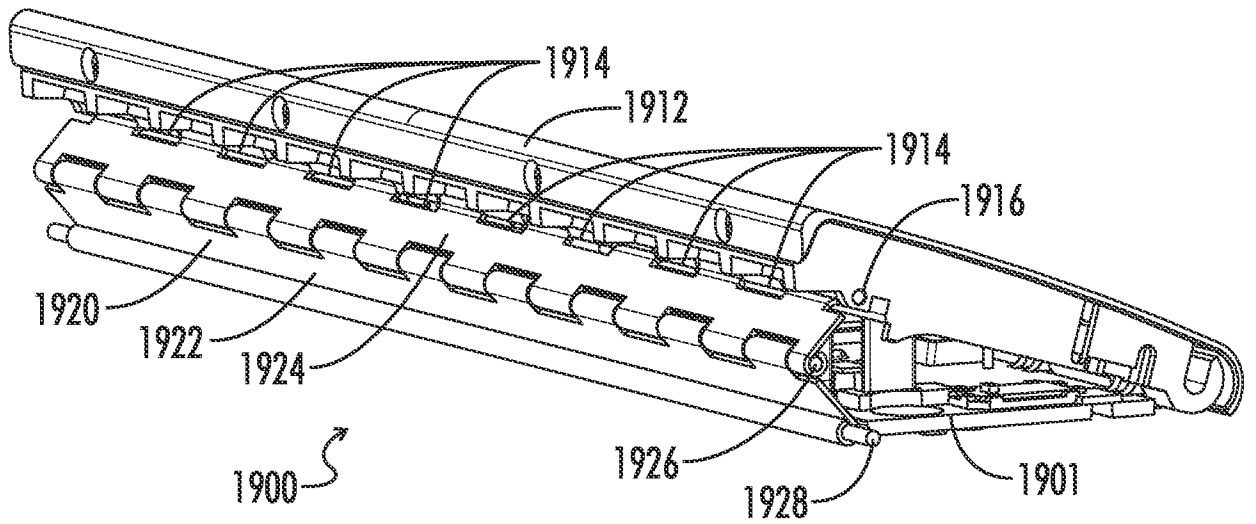


FIG. 18



*FIG. 19*

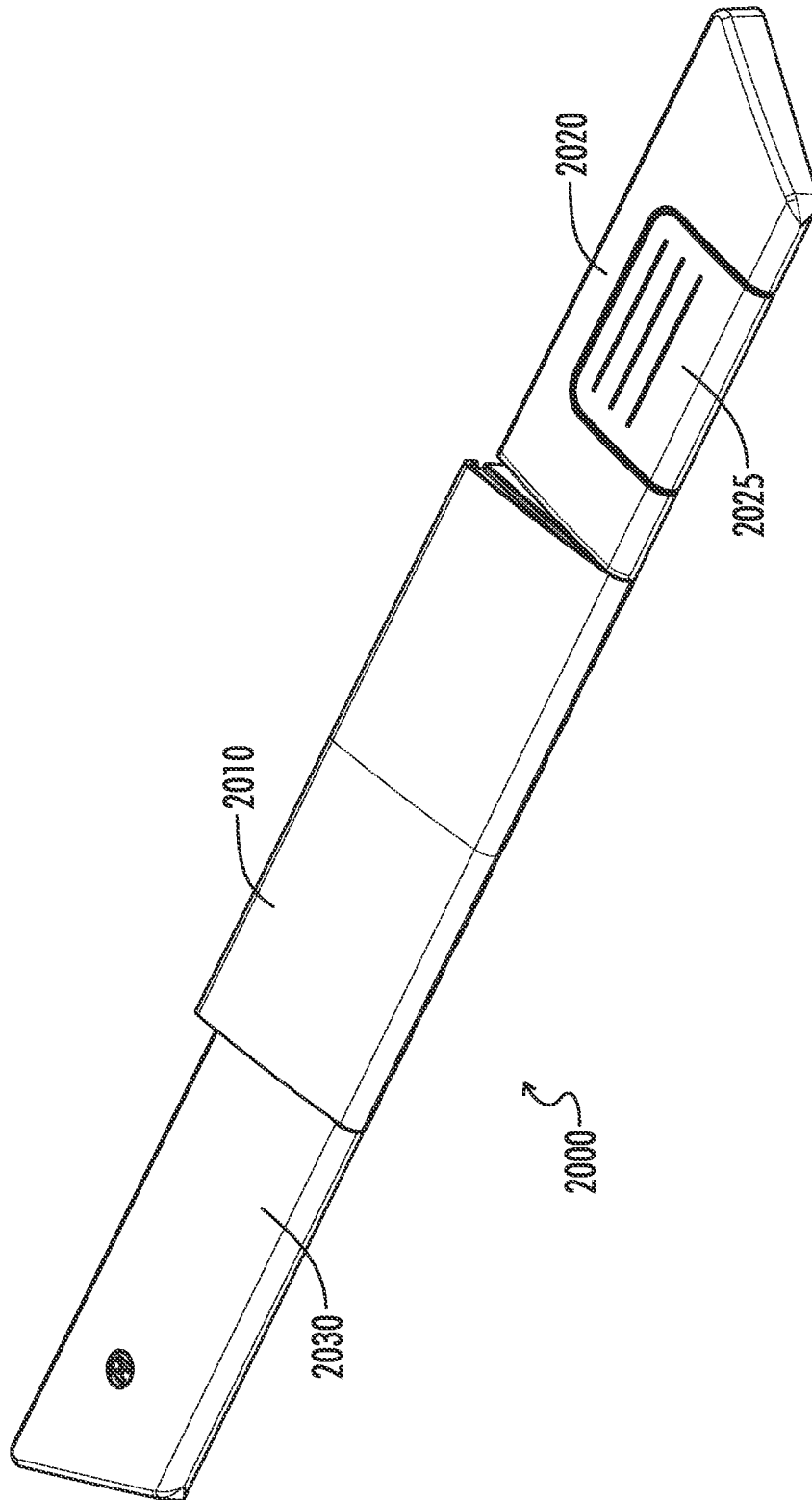


FIG. 20

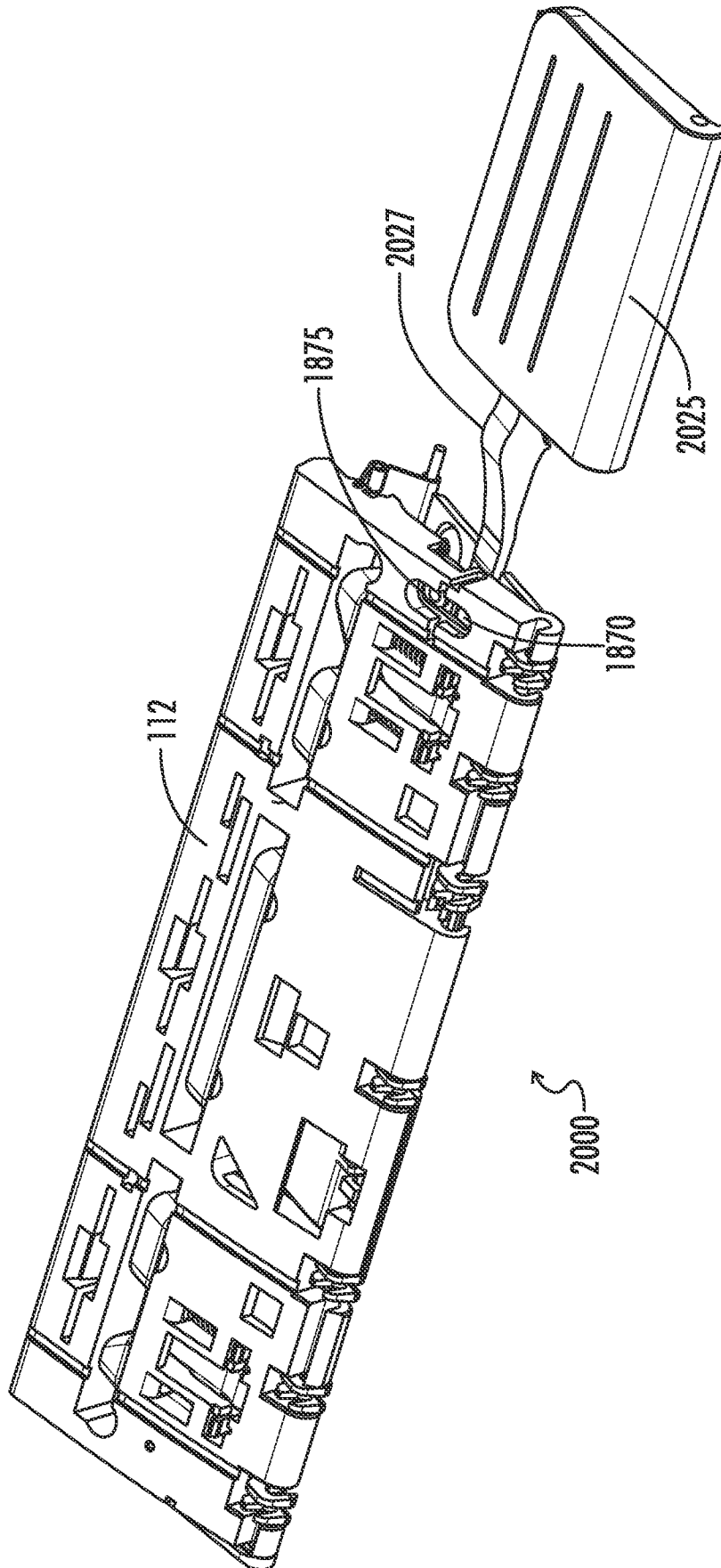


FIG. 21

15/17

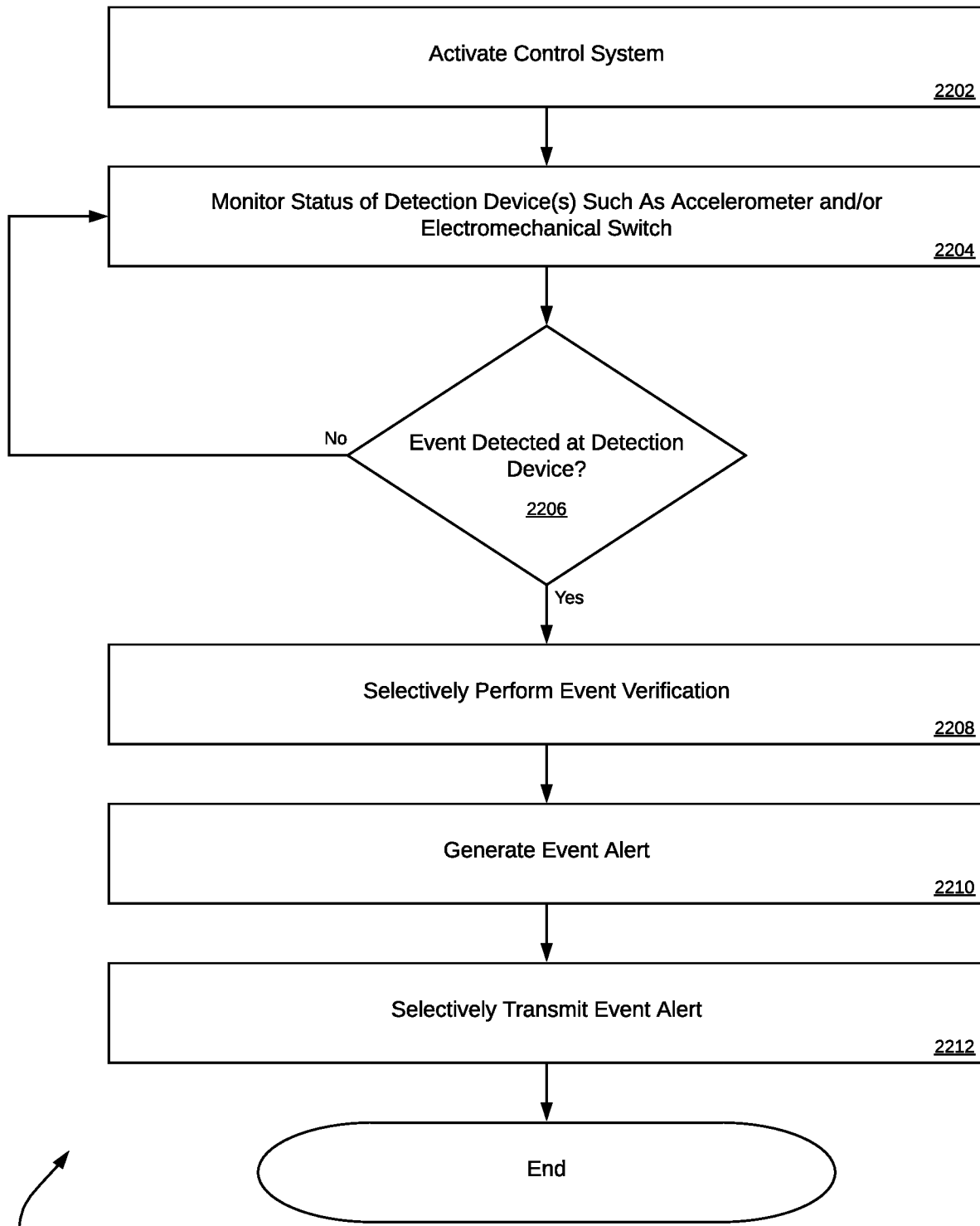


FIG. 22

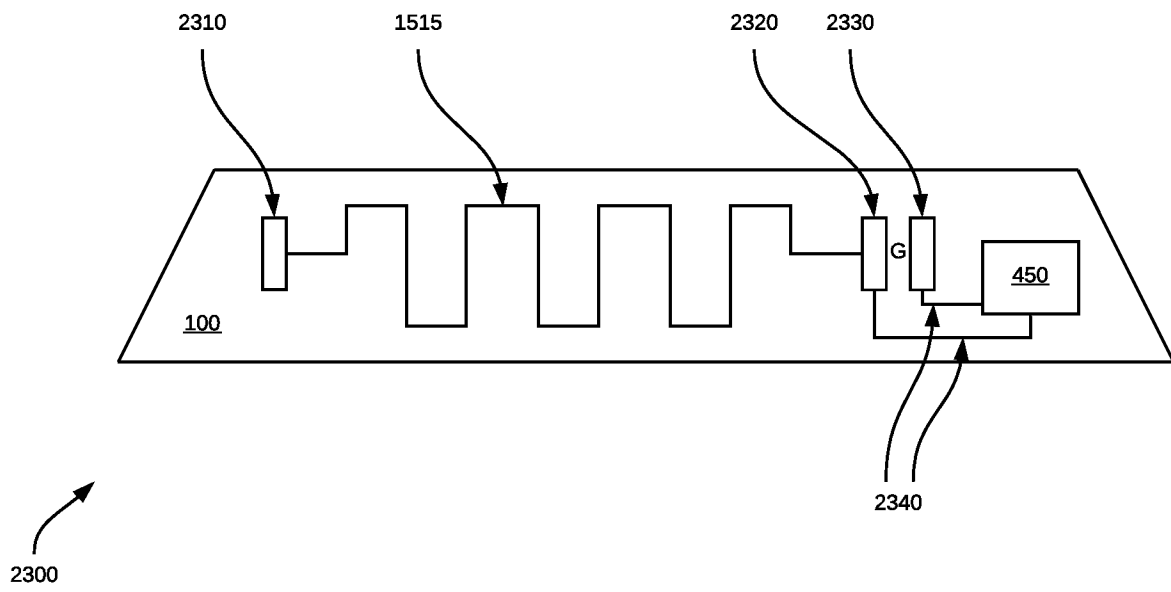


FIG. 23

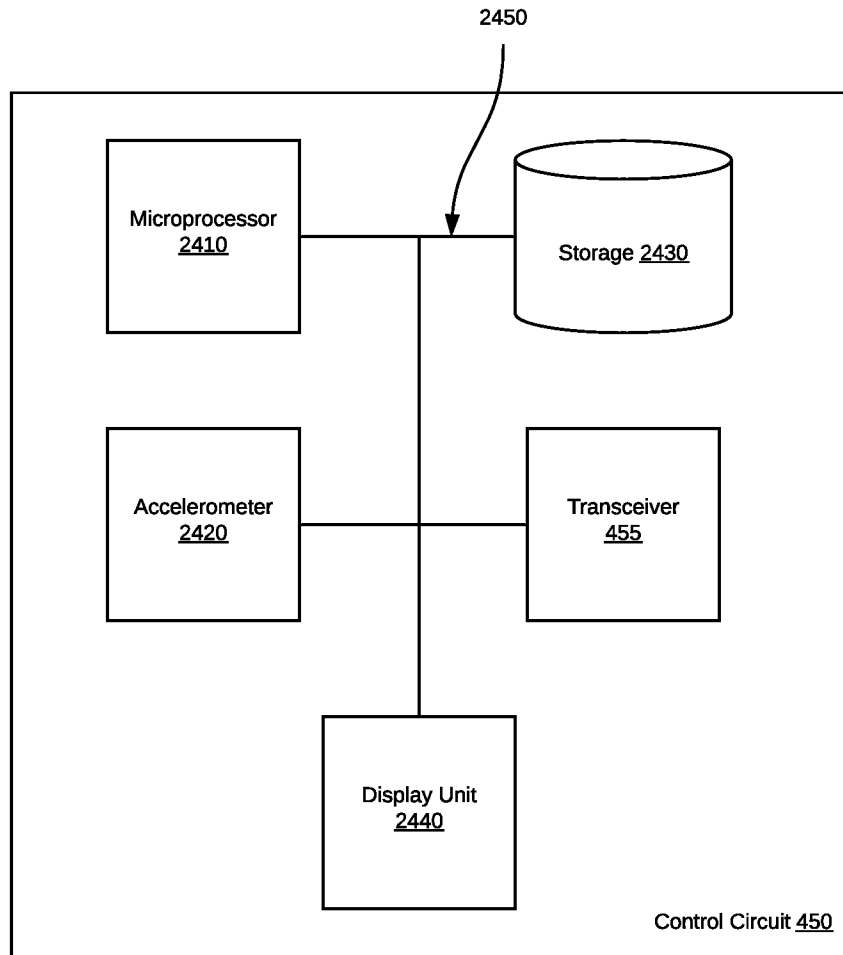


FIG. 24

## INTERNATIONAL SEARCH REPORT

International application No.

PCT/US 21/43913

A. CLASSIFICATION OF SUBJECT MATTER  
 IPC - E05B 47/00; E05B 45/06; E05B 45/08 (2021.01)  
 CPC - E05B 47/00; E05B 45/06; E05B 45/08

According to International Patent Classification (IPC) or to both national classification and IPC

## B. FIELDS SEARCHED

Minimum documentation searched (classification system followed by classification symbols)  
 See Search History document

Documentation searched other than minimum documentation to the extent that such documents are included in the fields searched  
 See Search History document

Electronic data base consulted during the international search (name of data base and, where practicable, search terms used)  
 See Search History document

## C. DOCUMENTS CONSIDERED TO BE RELEVANT

Category*	Citation of document, with indication, where appropriate, of the relevant passages	Relevant to claim No.
X --- A	US 2017/0051544 A1 (HavenLock inc.) 23 February 2017 (23.02.2017) entire document, especially: para [0008], [0067], [0113]	1, 6-8 ----- 2-5, 9-20
A	US 2010/0102978 A1 (Wittke) 29 April 2010 (29.04.2010) entire document	1-20
A	US 2016/0290009 A1 (ROBERT BOSCH GMBH) 06 October 2016 (06.10.2016) entire document	1-20
A	US 2016/0343188 A1 (August Home, Inc.) 24 November 2016 (24.11.2016) entire document	1-20
A	WO 2018/236310 A2 (DESI ALARM VE GUEVENLIK SISTEMLERI SANAYI VE TICARET ANONIM SIRKETI) 27 December 2018 (27.12.2018) entire document	1-2

Further documents are listed in the continuation of Box C.

See patent family annex.

## \* Special categories of cited documents:

"A" document defining the general state of the art which is not considered to be of particular relevance  
 "D" document cited by the applicant in the international application  
 "E" earlier application or patent but published on or after the international filing date  
 "L" document which may throw doubts on priority claim(s) or which is cited to establish the publication date of another citation or other special reason (as specified)  
 "O" document referring to an oral disclosure, use, exhibition or other means  
 "P" document published prior to the international filing date but later than the priority date claimed

"T" later document published after the international filing date or priority date and not in conflict with the application but cited to understand the principle or theory underlying the invention

"X" document of particular relevance; the claimed invention cannot be considered novel or cannot be considered to involve an inventive step when the document is taken alone

"Y" document of particular relevance; the claimed invention cannot be considered to involve an inventive step when the document is combined with one or more other such documents, such combination being obvious to a person skilled in the art

"&" document member of the same patent family

Date of the actual completion of the international search

04 October 2021

Date of mailing of the international search report

**NOV 01 2021**

Name and mailing address of the ISA/US

Mail Stop PCT, Attn: ISA/US, Commissioner for Patents  
 P.O. Box 1450, Alexandria, Virginia 22313-1450  
 Facsimile No. 571-273-8300

Authorized officer

Kari Rodriguez

Telephone No. PCT Helpdesk: 571-272-4300