

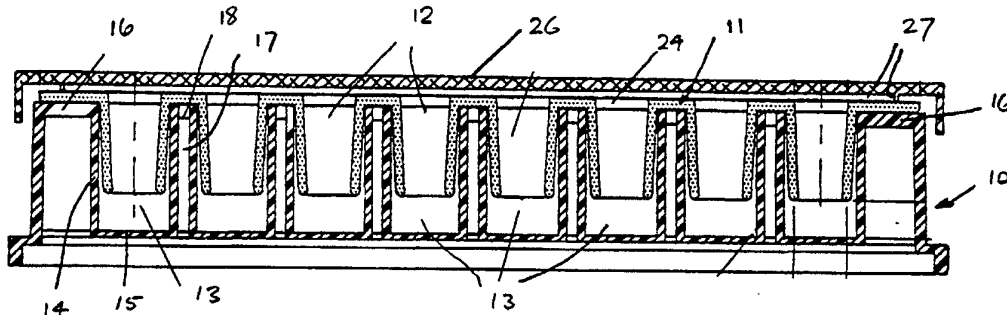

## INTERNATIONAL APPLICATION PUBLISHED UNDER THE PATENT COOPERATION TREATY (PCT)

(51) International Patent Classification <sup>5</sup> : C12M 3/06	A1	(11) International Publication Number: <b>WO 94/28111</b> (43) International Publication Date: 8 December 1994 (08.12.94)
<p>(21) International Application Number: PCT/GB94/01192</p> <p>(22) International Filing Date: 1 June 1994 (01.06.94)</p> <p>(30) Priority Data: 9311276.1 1 June 1993 (01.06.93) GB</p> <p>(71) Applicant (for all designated States except US): WHATMAN PLC [GB/GB]; Whatman House, St. Leonard's Road, 20/20 Maidstone, Kent ME16 0LS (GB).</p> <p>(72) Inventors; and</p> <p>(75) Inventors/Applicants (for US only): PHILPOTT, Richard, William [GB/GB]; Whatman plc, Whatman House, St. Leonard's Road, 20/20 Maidstone, Kent ME16 0LS (GB). JONES, Hywel [GB/GB]; Whatman plc, Whatman House, St. Leonard's Road, 20/20 Maidstone, Kent ME16 0LS (GB). MARCH, Elizabeth, Jane [GB/GB]; Whatman plc, Whatman House, St. Leonard's Road, 20/20 Maidstone, Kent ME16 0LS (GB).</p> <p>(74) Agent: PERKINS, Sarah; Stevens, Hewlett &amp; Perkins, 1 Serjeants' Inn, Fleet Street, London EC4Y 1LL (GB).</p>		<p>(81) Designated States: CA, JP, US, European patent (AT, BE, CH, DE, DK, ES, FR, GB, GR, IE, IT, LU, MC, NL, PT, SE).</p> <p>Published With international search report.</p>

## (54) Title: WELL INSERTS FOR USE IN TISSUE CULTURE



## (57) Abstract

Each well insert (12) has a side wall (19) which defines an insert well (12) which is closed at its base by a porous membrane (22). A flange (24) is provided at the upper edge of the side wall (19) which engages with the upper edges of the wells of a conventional microtitre plate (10). The well inserts may have a common flange member defining a strip of well inserts for cooperation with a row of wells (13) in the microtitre plate (10). The strip of well inserts (12) is particularly suited to automated test procedures where groups of well inserts (12) may be conveniently handled together.

**FOR THE PURPOSES OF INFORMATION ONLY**

Codes used to identify States party to the PCT on the front pages of pamphlets publishing international applications under the PCT.

AT	Austria	GB	United Kingdom	MR	Mauritania
AU	Australia	GE	Georgia	MW	Malawi
BB	Barbados	GN	Guinea	NE	Niger
BE	Belgium	GR	Greece	NL	Netherlands
BF	Burkina Faso	HU	Hungary	NO	Norway
BG	Bulgaria	IE	Ireland	NZ	New Zealand
BJ	Benin	IT	Italy	PL	Poland
BR	Brazil	JP	Japan	PT	Portugal
BY	Belarus	KE	Kenya	RO	Romania
CA	Canada	KG	Kyrgystan	RU	Russian Federation
CF	Central African Republic	KP	Democratic People's Republic of Korea	SD	Sudan
CG	Congo	KR	Republic of Korea	SE	Sweden
CH	Switzerland	KZ	Kazakhstan	SI	Slovenia
CI	Côte d'Ivoire	LI	Liechtenstein	SK	Slovakia
CM	Cameroon	LK	Sri Lanka	SN	Senegal
CN	China	LU	Luxembourg	TD	Chad
CS	Czechoslovakia	LV	Latvia	TG	Togo
CZ	Czech Republic	MC	Monaco	TJ	Tajikistan
DE	Germany	MD	Republic of Moldova	TT	Trinidad and Tobago
DK	Denmark	MG	Madagascar	UA	Ukraine
ES	Spain	ML	Mali	US	United States of America
FI	Finland	MN	Mongolia	UZ	Uzbekistan
FR	France			VN	Viet Nam
GA	Gabon				

WELL INSERTS FOR USE IN TISSUE CULTURE

This invention relates to well inserts intended primarily for use in conjunction with microtitre plates in cell and tissue culture.

5           Animal cell cultures are frequently grown in-vitro using a range of different types of container such as bottles or tubes made from either glass or plastic which may be treated for tissue culture applications. For more specialised biological, 10 biochemical, histological or immunological procedures, animal cell cultures may be grown in small volumes of growth medium within containers referred to as tissue culture inserts: A typical example of this product is cited in U.S. Patent 4,963,490. The base of the tissue 15 culture insert is composed of a thin porous membrane which may be either inorganic or polymeric, e.g. alumina or polycarbonate. The growth medium containing the animal cell culture is placed within the insert. This insert is then placed within an outer chamber also 20 containing a set volume of growth medium, the cells are cultured on the upper surface of the porous membrane. One problem encountered with such an insert is that cells have a tendency to grow up the inner surface of the side wall of the insert and interfere with the 25 monolayer of cells formed on the membrane.

For some techniques such as studies of cell to cell interactions, one type of cell culture can be grown on the upper membrane surface and another cell type can be grown on either the lower membrane surface 30 or the bottom surface of the outer chamber; the two cultures being separated by the porous membrane (co-cultivation).

Where multiple numbers of tests are required a microtitre plate format is often used for cell 35 growth. The standard format is a one-piece moulding providing an array of 96 wells arranged in 12 columns

- 2 -

of 8 wells. The internal diameter of each well is typically 7mm, the depth varies between 10-12mm and the overall size of the plate is 125mm x 85mm.

The flat bottom walls of these wells are  
5 moulded integrally with the whole plate from a plastics material and are non-porous. These wells contain the growth medium, and animal cells are grown on the bottom walls of the wells.

The miniaturisation of tests which is  
10 possible with the use of these multiple-well microtitre plates is advantageous, in addition to reducing the bulk of the well array and the relative ease of transport of the array, in that:

- 15 (i) tests can be miniaturised to reduce the cost of expensive materials e.g. growth medium, additives and assay chemicals,
- (ii) multiple numbers of wells can be manually dosed with liquid simultaneously,
- (iii) automated equipment is available for rapid  
20 addition of liquids to individual wells either sequentially or simultaneously, and
- (iv) automated equipment is available for rapid analysis of test assays e.g. by UV spectrophotometry and fluorescence.

25 However, these microtitre plates, used alone, have some disadvantages:

- (i) the lack of a porous growth support and barrier layer prevents their use to provide
  - a) assays such as chemical transport studies  
30 or certain types of toxicology testing procedures (e.g. the Fluorescein leakage test), and
  - b) growth of two different cell types within the same well for co-cultivation of cells for cell-to-cell interaction studies.  
35
- (ii) The majority of epithelial cells do not

differentiate or polarize on non-porous supports.

(iii) Cells cannot be studied by electron microscopy.

5 (iv) Adhered cells cannot be transferred between wells.

According to the present invention in one aspect there is provided a well insert element for use with a microtitre plate, comprising a transparent side  
10 wall of frusto-conical form having an outwardly projecting flange at its upper, larger diameter, end and having its base end closed by a porous inorganic or polymeric membrane, the periphery of which is sealed with respect to the side wall, and means for spacing  
15 the side wall uniformly from a surrounding side wall of a well of a microtitre plate.

In preferred forms, the invention provides an array of well insert elements for use with a microtitre plate, each well insert element comprising a trans-  
20 parent side wall of frusto-conical form having its base end closed by a porous inorganic or polymeric membrane, the periphery of which is sealed with respect to the side wall and having an outwardly projecting flange at its upper, larger diameter, end, the flanges of the  
25 well insert elements merging together to form an integral support flange for the array, and the array further having means for spacing the side walls of the elements uniformly from surrounding side walls of respective cells of the microtitre plate. The support  
30 flange is arranged to support the array on a microtitre plate which provides an individual cell to receive a well insert element of the array. The array may conveniently be in the form of a strip providing, for example, a row of 8 insert elements in length and being  
35 a single insert element wide.

Preferably, the internal diameter of the base

is in the range 3.0mm to 4.5mm. Ideally the diameter is substantially 3.2mm.

The invention also provides in combination a microtitre plate moulded from a plastics material and providing an array of individual wells which are arranged in rows and which are open at the top and closed at the bottom, a strip of well insert elements moulded from a plastics material and arranged to be suspended in respective wells of one of said rows, each of said insert elements being open at the top and having a frusto-conical side wall defining an insert well which is closed at its lower end by an inorganic or polymeric porous membrane the periphery of which is sealed with respect to said side wall, the upper ends of said frusto-conical side walls being formed integrally with a support flange which rests on the microtitre plate and which covers annular gaps formed between the side walls of the wells of the plate and the external surfaces of the side walls of the respective insert elements, and spacing means for spacing the side walls of the insert elements uniformly from the surrounding side walls of the respective wells of the plate.

The distance between the bottom of each well and the underside of the membrane of the insert element occupying the well is preferably in the range of 0.5mm to 3mm. Ideally the distance is substantially 1mm.

The invention will now be described in more detail with reference by way of example to the accompanying drawings in which:

Figure 1 shows in sectional elevation a well insert element according to the invention in place over a row of wells of a microtitre plate,

Figure 2 is a plan view corresponding to Figure 1 but omitting the lid, and

Figure 3 shows on a larger scale a single

well of the insert element.

Referring to Figures 1 and 2 of the drawings, the microtitre plate 10 is an integral plastics moulding which is transparent in this instance and which provides an array of 96 wells arranged in twelve rows of eight wells. The well insert 11 has, arranged in a strip, eight insert elements 12 disposed in the individual wells 13 of one row of eight.

Each well 13 has a substantially cylindrical side wall 14 and a bottom wall 15. The top wall 16 of the plate 10 is continuous along the periphery of the plate but is discontinuous between the wells, the side walls 14 of adjoining wells being interconnected by vertical webs 17 which terminate at 18, short of the top edges of the side walls 14.

The well insert 11 (see also Figure 3) comprises a strip which is a transparent plastics moulding with the eight insert elements 12 forming the strip arranged so as to be centred in the respective wells 13 of a single row. Each well insert element has a frusto-conical side wall 19 of substantially uniform thickness except at its lower end 20, which is rounded. A porous membrane 22, made for example of alumina or polycarbonate, is sealed across the lower end of the side wall of the insert. An acute angle 23 is formed where the membrane joins the rounded end 20. An undercut region is thereby formed where the membrane meets the periphery of the side wall. The undercut region is effective in preventing cells growing up the inner surface of the side wall of the insert element beyond the upper surface of a monolayer of cells grown on the membrane.

The well insert elements are joined together at their upper ends by a flange member 24 extending along the length of the row of insert elements. When in use the flange member 24 rests on the tops 25 of the

side walls of the wells, which project a small distance above the level of the top wall 16 of the plate 10.

This arrangement prevents or reduces loss of liquid from the wells by evaporation and reduces the risk of well-to-well interference in the tests being carried out. A lid 26 (not shown in Figure 3) for the plate 10 has a rib 27 on its underside which rests on the ends of the flange member 24.

Small projections (not shown) are formed on the underside of the flange member adjacent its opposite ends beyond the outermost insert elements and engage in the annular gap between the sidewalls of the endmost wells and their insert elements. These projections serve to centralise all of the insert elements of the strip in their respective wells.

In the illustrated construction the width of the flange member 24, which is one insert element wide, is small enough to allow a strip of insert elements to be located in each row of wells in the plate 10 with suitable clearances between adjoining strips to facilitate handling of the strips. With a conventional microtitre plate twelve separate strips of insert elements may therefore be used. Alternatively, the insert element may provide two or more rows of insert elements and in any desired form of array having regard to the spacing of the wells in the plate. In this way a plurality of separate strips or arrays of insert elements are provided for a single conventional microtitre plate. By providing a plurality of strips or arrays for use with a single microtitre plate, each strip or array may be used for a separate multiple test thereby making the organisation and management of the multiple tests easier and reducing the risk of error. Also, the automated handling of the individual strips or arrays is greatly simplified where the strips or arrays extend over a row of wells of the microtitre

plate since then the strip or array may be grasped at the edges of the plate.

In a particular design of well insert strip according to the invention for use with one row of 8  
5 wells of a standard 96 well microtitre plate in which the wells are centred at intervals of  $9\text{mm} \pm 0.5\text{mm}$  and each well is substantially cylindrical, having internal diameters of  $6.5\text{mm} \pm 0.5\text{mm}$  at its top and base ends, the top of the well being  $0.5\text{mm}$  wider than the base end,  
10 the strip has a total length of  $79\text{mm}$  and a width of  $8.8\text{mm} \pm 0.1\text{mm}$ , the pitch spacing of the inserts corresponds to that of the wells, and each insert has a constant sidewall thickness of  $0.8\text{mm} \pm 0.1\text{mm}$ , an internal diameter of  $4\text{mm} \pm 0.1\text{mm}$  at the top and an  
15 internal diameter of  $3.2\text{mm} \pm 0.1\text{mm}$  at the base. The internal diameter of the insert must be in the range  $3.00\text{mm}$  to  $4.5\text{mm}$  so as to enable the base of the insert to be examined by optical microscopy. The meniscus produced by liquid in the well prevents proper use of a  
20 microscope in this manner when the internal diameter of the well is reduced below  $3.0\text{mm}$ . The preferred range of distances between the underside of the membrane and the upper surface of the base of the well is  $0.5\text{mm}$  to  $3\text{mm}$ . Ideally, the distance is  $1\text{mm} \pm 0.1\text{mm}$ . Within  
25 this range of distances free diffusion of molecules from the lower well is enabled. This range of distances is also particularly suitable for co-culture where soluble mediators are able to freely diffuse between the two layers of cells which are physically  
30 separated.

In a typical use of the plate and insert strip 11 a predetermined volume of a growth liquid is placed in each well, the insert strip 11 is lowered into the wells 13 and a predetermined volume of a  
35 growth medium suitable seeded with cells is placed in each well of the well insert. Growth of the cells to

confluence is observed, and examined, by optical microscopy if desired. The insert strip 11 can be removed to enable washing and subsequent treatment of the cell growth in the wells of the insert by reagents  
5 or other treatment can be carried out in all of the wells of the insert simultaneously. Additionally or alternatively, cell growth on the bottom wall of the wells 13 may be examined and treated.

As mentioned above, the bottom edge 20 of the  
10 side wall of the well insert to which the porous membrane is attached is designed to produce an acute angle between the insert wall and membrane, e.g. by use of a rounded profile. At the point of attachment of the membrane to the element wall, the resulting acute  
15 angle 23 discourages growth of cells up the side wall of the insert element, restricting cell growth to the membrane surface only. This is required to prevent interference with the layer of cells on the membrane surface. Continuation of growth from the membrane up  
20 the walls of the well can result in the confluent layer on the membrane being disturbed when cells slough from the walls.

The strip 11 may be manufactured in a moulded plastic polymer material such as polystyrene,  
25 polycarbonate, polypropylene or similar material. The polymer may be non-pigmented to give a visually clear material or may contain a pigment to reduce optical clarity. An example is a black pigment which may be used to reduce stray fluorescent light when using  
30 sensitive types of analytical detectors.

The length of the flange member is selected to be long enough to enable the strip to be manually removed easily from the microtitre plate, but short enough to enable the lid of the microtitre plate to be  
35 fitted over the well inserts. 79mm  $\pm$  0.25mm has been found to be a good length for these purposes.

- 9 -

In one example the well insert has a capacity of 75 microlitres for the addition of growth medium. Maintaining the internal diameter of the lower end of the side wall at a value greater than 3.0mm, allows the growth medium to be introduced within the well insert without an air-lock forming over the base of the well insert below the growth medium. Such an air-lock can be difficult to remove and tends to interfere with proper functioning of the device. A volume of 150 to 200 microlitres of growth medium is required in the well of the microtitre plate in the presence of the insert element. Maintaining the external diameter of the base of the well insert to less than 5.6mm prevents an air-lock forming on the underside of the well insert element, within the growth medium on addition of the well insert element to the microtitre well. Such an air-lock causes displacement of growth medium from the microtitre well, prevents proper functioning of the device and can also result in cross-contamination of growth medium within adjacent wells. These measures combined with the provision for a uniform gap between the side wall of the insert and the wall of the microtitre well allows proper venting of excess air from the well insert element and microtitre well.

30

35

CLAIMS

1. A well insert element for use with a microtitre plate, comprising a transparent side wall of frusto-conical form having an outwardly projecting flange at its upper, larger diameter, end and having its base end closed by a porous membrane, the periphery of which is sealed with respect to the side wall, and means for spacing the side wall uniformly from a surrounding side wall of a well of a microtitre plate.
2. A well insert element as claimed in claim 1, wherein the internal diameter of the lower end of the side wall is substantially 3.2mm.
3. A well insert element as claimed in claim 1 or claim 2, wherein said means for spacing the side wall of the element uniformly from a surrounding side wall of a well of a microtitre plate comprises projections formed on the underside of the support flange and/or on the radially outer surface of the side wall of the well insert element.
4. A well insert element as claimed in any one of claims 1 to 3, wherein the inner surface of the side wall of the well insert element forms an acute angle to the plane of the porous membrane thereby providing an undercut region where the side wall of the well insert element joins the porous membrane.
5. An array of well insert elements for use with a microtitre plate, each well insert element comprising a transparent side wall of frusto-conical form having its base end closed by a porous inorganic or polymeric membrane, the periphery of which is sealed with respect to the side wall and having an outwardly projecting flange at its upper, larger diameter, end, the flanges of the well insert elements merging together to form an integral support flange for the array, and the array further having means for spacing the side walls of the

elements uniformly from surrounding side walls of respective cells of the microtitre plate.

6. An array as claimed in claim 2, wherein the array is in the form of a strip with a plurality of well insert elements along its length and being a single insert element in width.

7. In combination a microtitre plate moulded from a plastics material and providing an array of individual wells which are arranged in rows and which are open at the top and closed at the bottom, a strip of well insert elements moulded from a plastics material and arranged to be suspended in respective wells of one of said rows, each of said well insert elements being open at the top and having a frusto-conical side wall defining a well which is closed at its lower end by an inorganic or polymeric porous membrane the periphery of which is sealed with respect to said side wall, the upper ends of said frusto-conical side walls being formed integrally with a support flange which rests on the microtitre plate and which covers annular gaps formed between the side walls of the wells of the plate and the external surfaces of the side walls of the respective well insert elements, and spacing means for spacing the side walls of the well insert elements uniformly from the surrounding side walls of the respective wells of the plate.

8. The combination claimed in claim 7, wherein the distance between the bottom of each well and the underside of the membrane of the insert element occupying the well is substantially 1mm.

9. The combination claimed in claim 7 or claim 8, wherein the internal diameter of the lower end of the side wall of each of said well insert elements is substantially 3.2mm.

10. The combination claimed in any one of claims 7 to 9, wherein said spacing means comprises

projections formed integrally with the strip and engaging the internal surfaces of the side walls of two or more of the wells at the upper ends of said side walls.

5

10

15

20

25

30

35

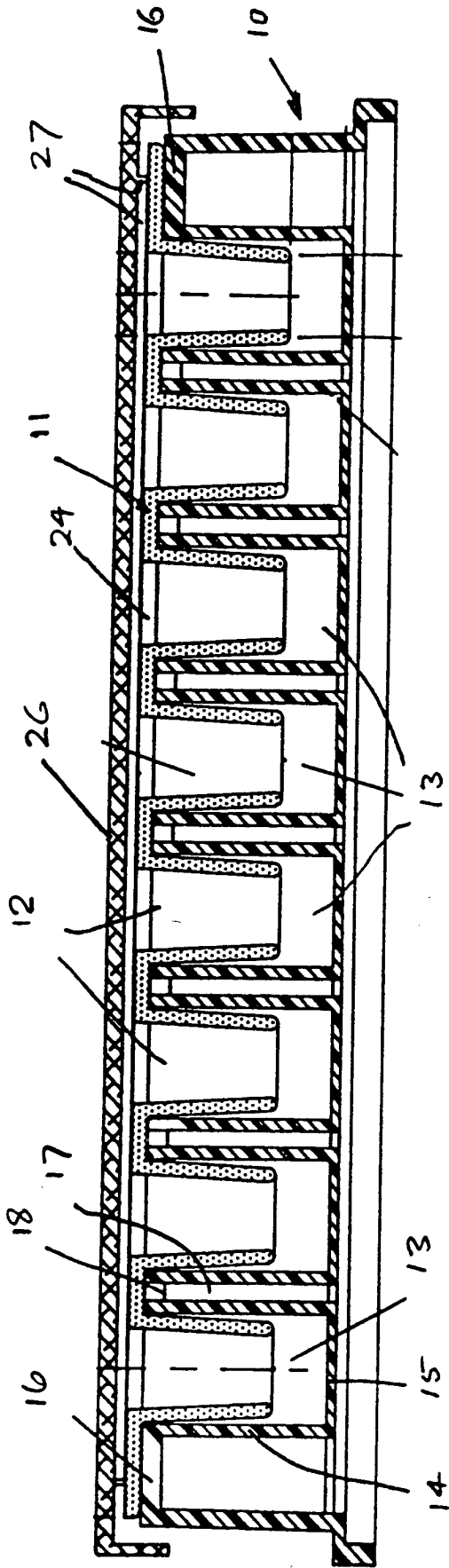

FIG. 1

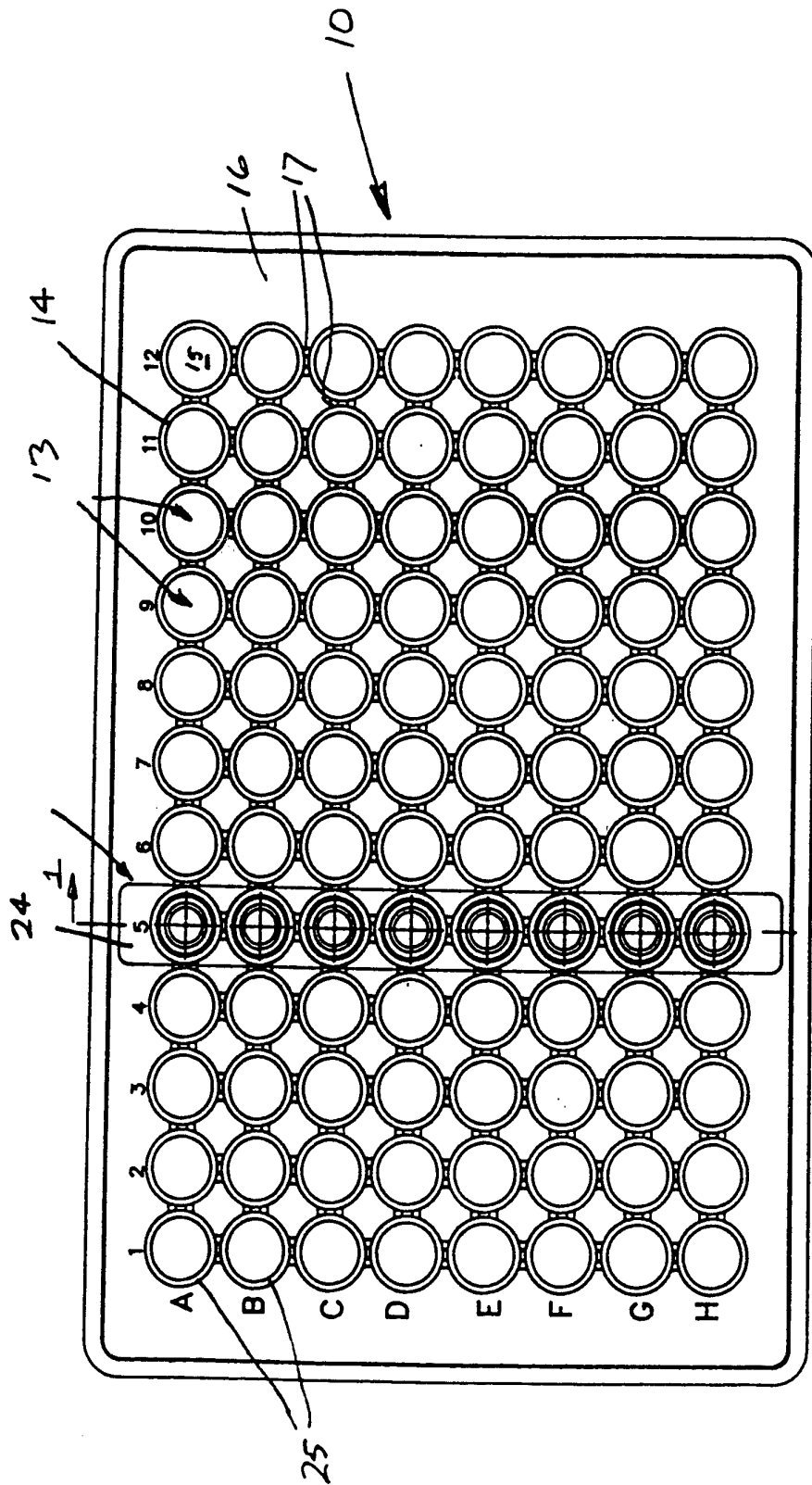

FIG. 2

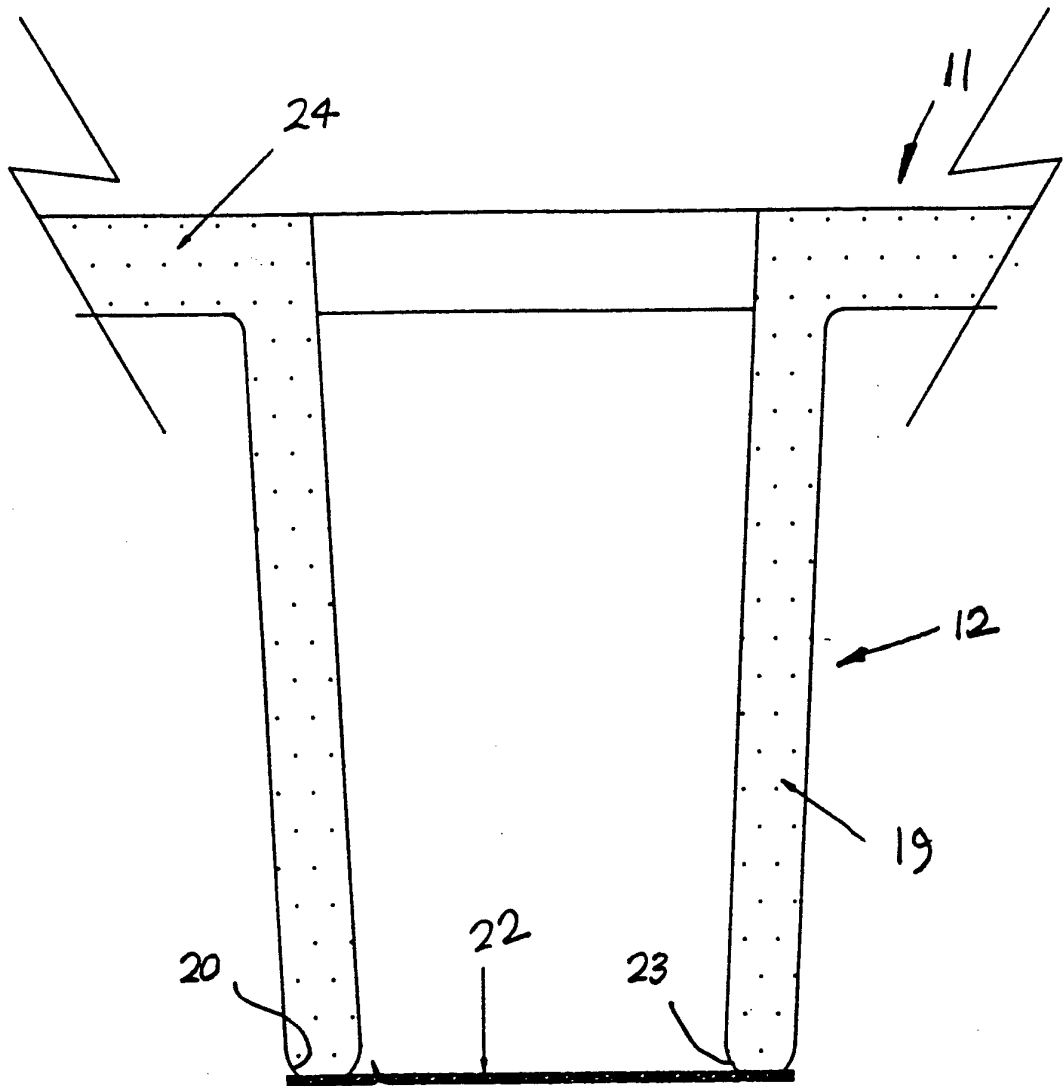

FIG 3

## INTERNATIONAL SEARCH REPORT

International Application No

PCT/GB 94/01192

A. CLASSIFICATION OF SUBJECT MATTER  
IPC 5 C12M3/06

According to International Patent Classification (IPC) or to both national classification and IPC

## B. FIELDS SEARCHED

Minimum documentation searched (classification system followed by classification symbols)  
IPC 5 C12M

Documentation searched other than minimum documentation to the extent that such documents are included in the fields searched

Electronic data base consulted during the international search (name of data base and, where practical, search terms used)

## C. DOCUMENTS CONSIDERED TO BE RELEVANT

Category *	Citation of document, with indication, where appropriate, of the relevant passages	Relevant to claim No.
Y	EP,A,0 239 697 (COSTAR CORPORATION) 7 October 1987 see page 2, column 1, line 51 - column 2, line 6; claims; figures 1-5 see page 3, column 3, line 32 - line 55 see page 4, column 5, line 45 - line 57 ---	1-10
Y	COSTAR EUROPE PRODUCT INFORMATION BROCHURE November 1986, BADHOEVEDORP, NL pages 1 - 12 'COSTAR GIVES MEMBRANE TECHNOLOGY NEW DIMENSIONS.' see page 8 - page 11 ---	1-10
A	EP,A,0 495 213 (BECTON DICKINSON AND COMPANY) 22 July 1992 see the whole document -----	1-10

 Further documents are listed in the continuation of box C. Patent family members are listed in annex.

## \* Special categories of cited documents :

- "A" document defining the general state of the art which is not considered to be of particular relevance
- "E" earlier document but published on or after the international filing date
- "L" document which may throw doubts on priority claim(s) or which is cited to establish the publication date of another citation or other special reason (as specified)
- "O" document referring to an oral disclosure, use, exhibition or other means
- "P" document published prior to the international filing date but later than the priority date claimed

- "T" later document published after the international filing date or priority date and not in conflict with the application but cited to understand the principle or theory underlying the invention
- "X" document of particular relevance; the claimed invention cannot be considered novel or cannot be considered to involve an inventive step when the document is taken alone
- "Y" document of particular relevance; the claimed invention cannot be considered to involve an inventive step when the document is combined with one or more other such documents, such combination being obvious to a person skilled in the art.
- "&" document member of the same patent family

Date of the actual completion of the international search

29 August 1994

Date of mailing of the international search report

05 -09- 1994

Name and mailing address of the ISA

European Patent Office, P.B. 5818 Patentlaan 2  
NL - 2280 HV Rijswijk  
Tel. (+ 31-70) 340-2040, Tx. 31 651 epo nl,  
Fax: (+ 31-70) 340-3016

Authorized officer

Ryckebosch, A

## INTERNATIONAL SEARCH REPORT

information on patent family members

International Application No

PCT/GB 94/01192

Patent document cited in search report	Publication date	Patent family member(s)	Publication date
EP-A-0239697	07-10-87	US-A- 5026649	25-06-91
		DE-A- 3686050	20-08-92
		JP-B- 5017830	10-03-93
		JP-A- 62220184	28-09-87
		US-A- 5215920	01-06-93
-----			
EP-A-0495213	22-07-92	AU-B- 643852	25-11-93
		AU-A- 8818391	25-06-92
		CA-A- 2055966	20-06-92
		JP-A- 5003779	14-01-93
-----			