



(86) **Date de dépôt PCT/PCT Filing Date:** 2014/09/25
 (87) **Date publication PCT/PCT Publication Date:** 2015/04/02
 (85) **Entrée phase nationale/National Entry:** 2016/03/24
 (86) **N° demande PCT/PCT Application No.:** US 2014/057531
 (87) **N° publication PCT/PCT Publication No.:** 2015/048337
 (30) **Priorités/Priorities:** 2013/09/25 (US61/882,187);
 2014/02/28 (US61/946,095); 2014/09/25 (US14/497,108)

(51) **Cl.Int./Int.Cl. B26B 11/00** (2006.01)
 (71) **Demandeur/Applicant:**
 DAN-O-TOOL, LLC, US
 (72) **Inventeur/Inventor:**
 RAYMOND, DANIEL J., US
 (74) **Agent:** GOWLING WLG (CANADA) LLP

(54) **Titre : ENSEMBLE OUTIL POLYVALENT**
 (54) **Title: MULTI-TOOL ASSEMBLY**

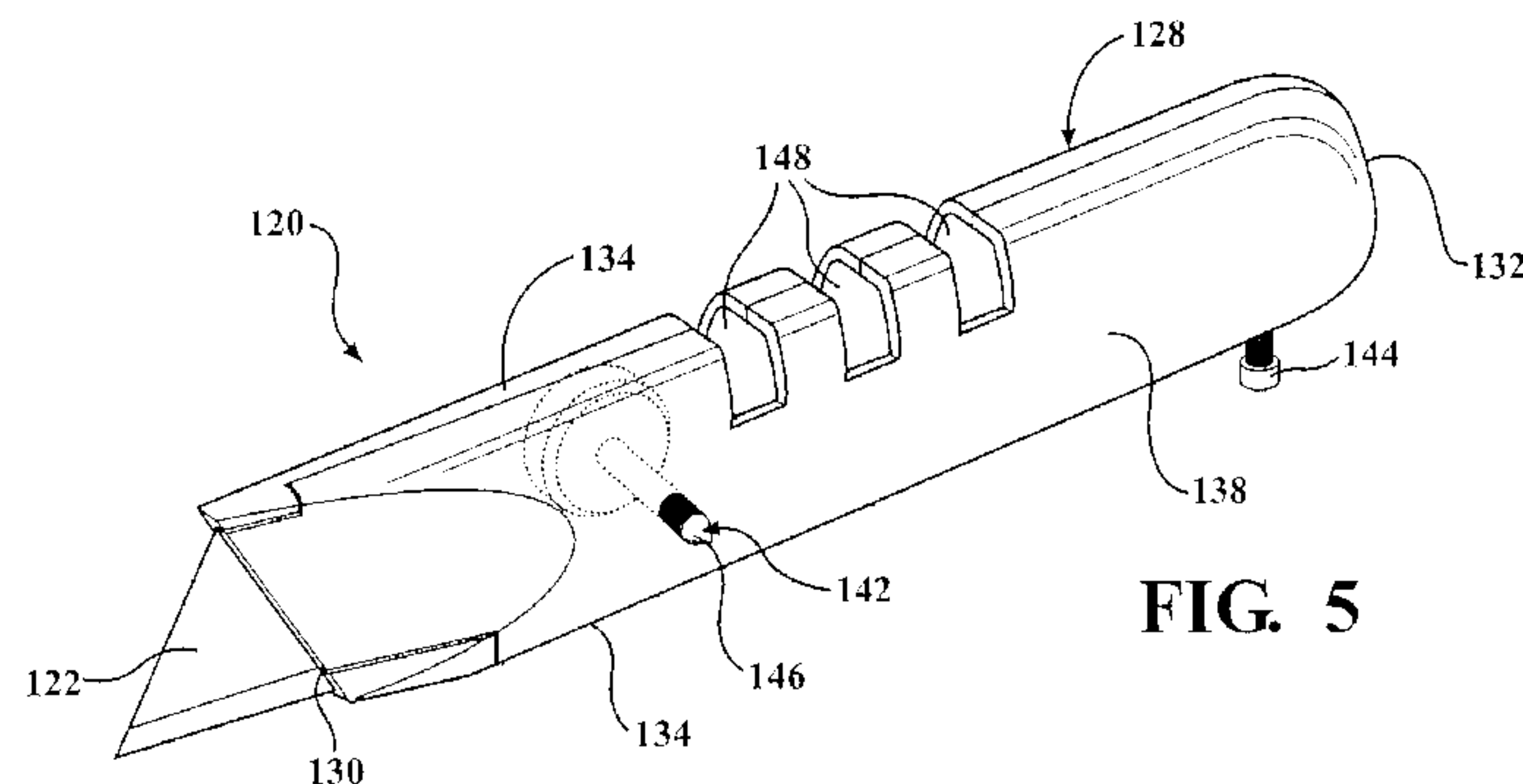

FIG. 5

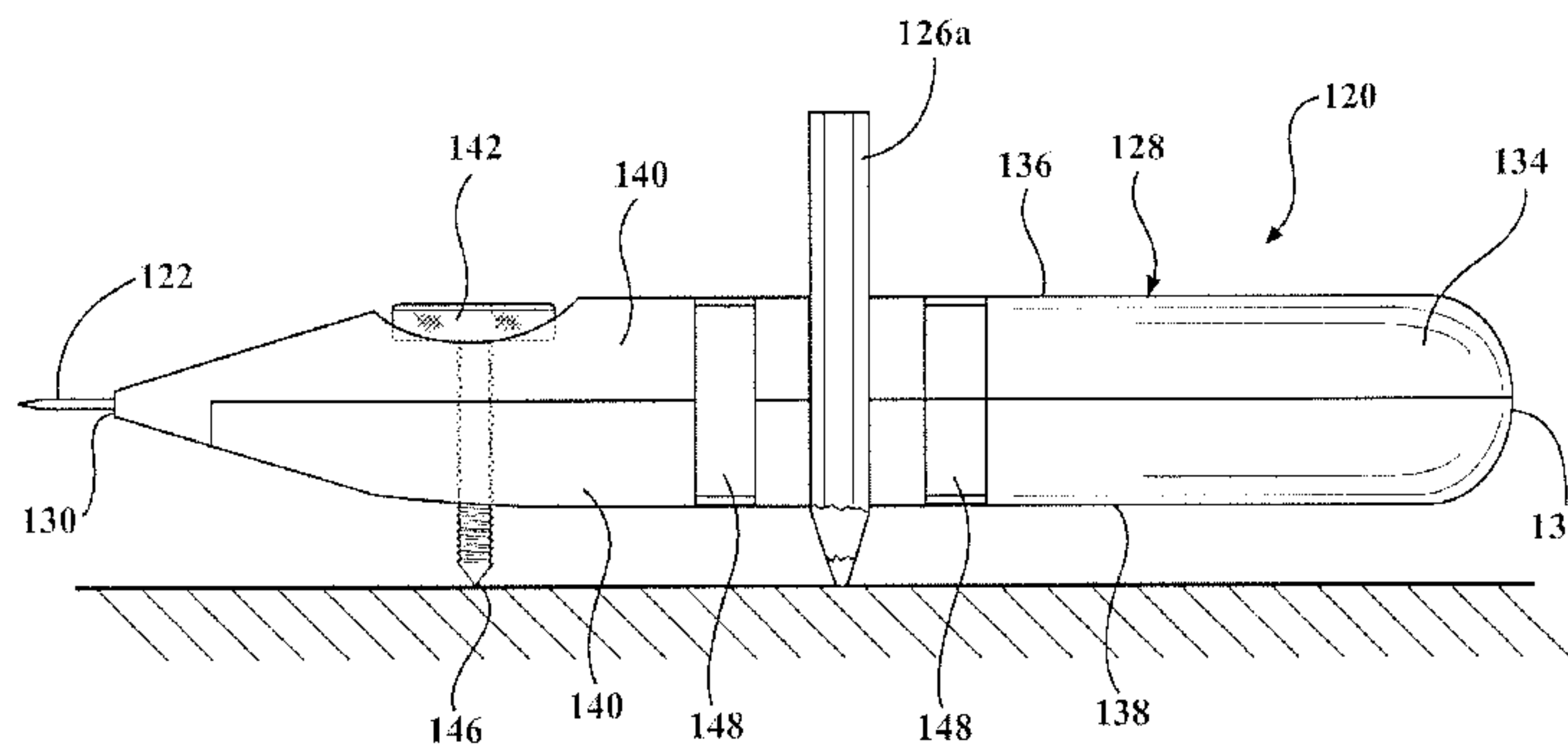

FIG. 6

(57) **Abrégé/Abstract:**

An improved multi-tool assembly (20) which includes a housing (28) that extends between opposing first and second longitudinal ends is provided. The multi-tool assembly further includes a blade (22) which is partially disposed within the housing and which

(57) **Abrégé(suite)/Abstract(continued):**

projects out of the first longitudinal end (30) of the housing. The housing has a slot (24) which opens to the second longitudinal end (32) of the housing and at least one tool engaging element (44) disposed at least partially within the slot of releasably securing a tool (26) in the slot at the second longitudinal end of the housing such that the tool projects out of the second longitudinal end of the housing.

(12) INTERNATIONAL APPLICATION PUBLISHED UNDER THE PATENT COOPERATION TREATY (PCT)

(19) World Intellectual Property
Organization
International Bureau(10) International Publication Number
WO 2015/048337 A1(43) International Publication Date
2 April 2015 (02.04.2015)(51) International Patent Classification:
B26B 11/00 (2006.01)

(21) International Application Number:

PCT/US2014/057531

(22) International Filing Date:

25 September 2014 (25.09.2014)

(25) Filing Language:

English

(26) Publication Language:

English

(30) Priority Data:

61/882,187 25 September 2013 (25.09.2013) US

61/946,095 28 February 2014 (28.02.2014) US

14/497,108 25 September 2014 (25.09.2014) US

(71) Applicant: **DAN-O-TOOL, LLC** [US/US]; 40 West Morley, Suite B, Saginaw, MI 48601 (US).(72) Inventor: **RAYMOND, Daniel, J.**; 40 West Morley, Suite B, Saginaw, MI 48601 (US).(74) Agents: **STEARNS, Robert** et al.; Dickinson Wright PLLC, 2600 W. Big Beaver Road, Suite 300, Troy, MI 48084-3312 (US).(81) Designated States (*unless otherwise indicated, for every kind of national protection available*): AE, AG, AL, AM, AO, AT, AU, AZ, BA, BB, BG, BH, BN, BR, BW, BY, BZ, CA, CH, CL, CN, CO, CR, CU, CZ, DE, DK, DM, DO, DZ, EC, EE, EG, ES, FI, GB, GD, GE, GH, GM, GT, HN, HR, HU, ID, IL, IN, IR, IS, JP, KE, KG, KN, KP, KR, KZ, LA, LC, LK, LR, LS, LU, LY, MA, MD, ME, MG, MK, MN, MW, MX, MY, MZ, NA, NG, NI, NO, NZ, OM, PA, PE, PG, PH, PL, PT, QA, RO, RS, RU, RW, SA, SC, SD, SE, SG, SK, SL, SM, ST, SV, SY, TH, TJ, TM, TN, TR, TT, TZ, UA, UG, US, UZ, VC, VN, ZA, ZM, ZW.(84) Designated States (*unless otherwise indicated, for every kind of regional protection available*): ARIPO (BW, GH, GM, KE, LR, LS, MW, MZ, NA, RW, SD, SL, ST, SZ, TZ, UG, ZM, ZW), Eurasian (AM, AZ, BY, KG, KZ, RU, TJ, TM), European (AL, AT, BE, BG, CH, CY, CZ, DE,

[Continued on next page]

(54) Title: MULTI-TOOL ASSEMBLY

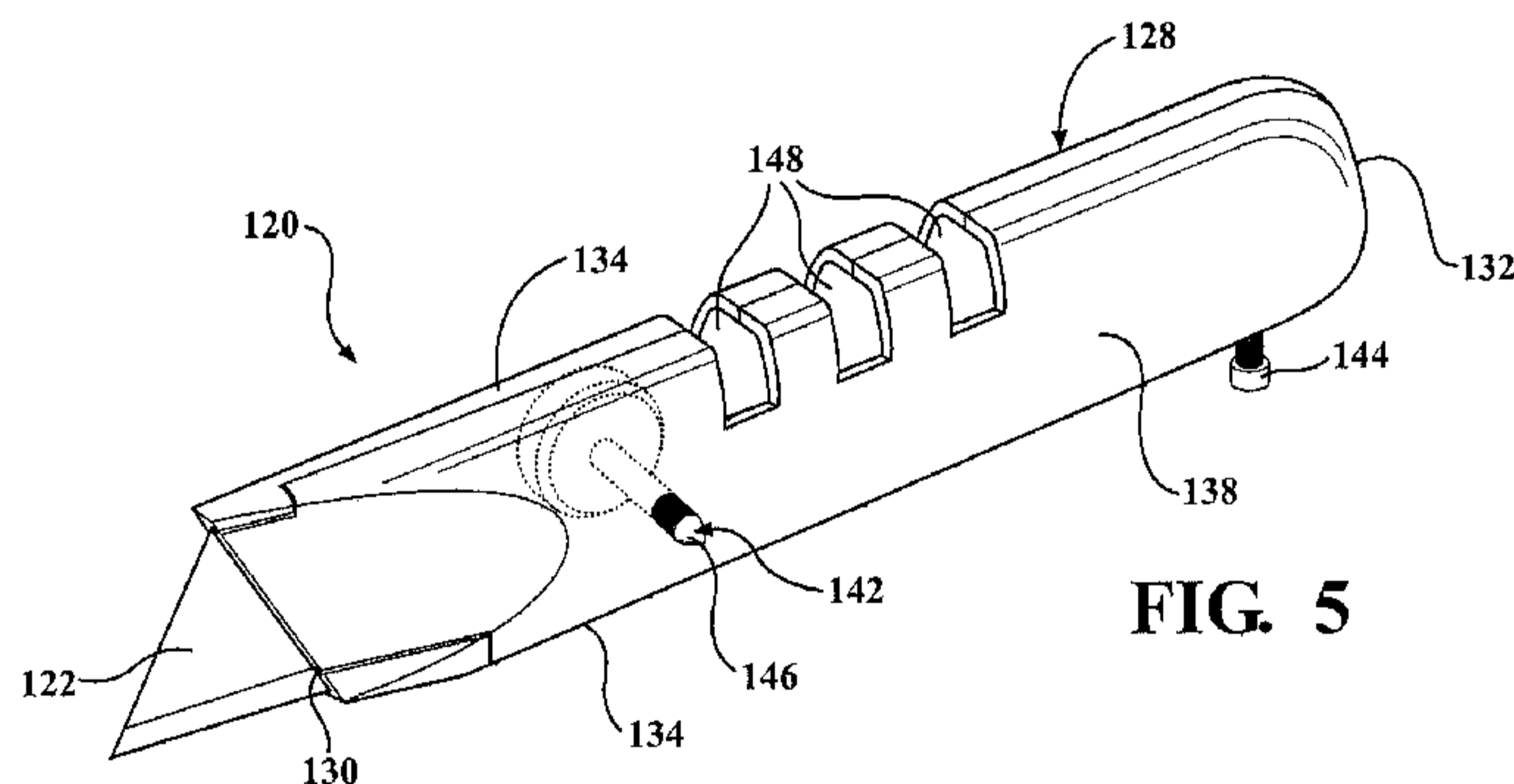

FIG. 5

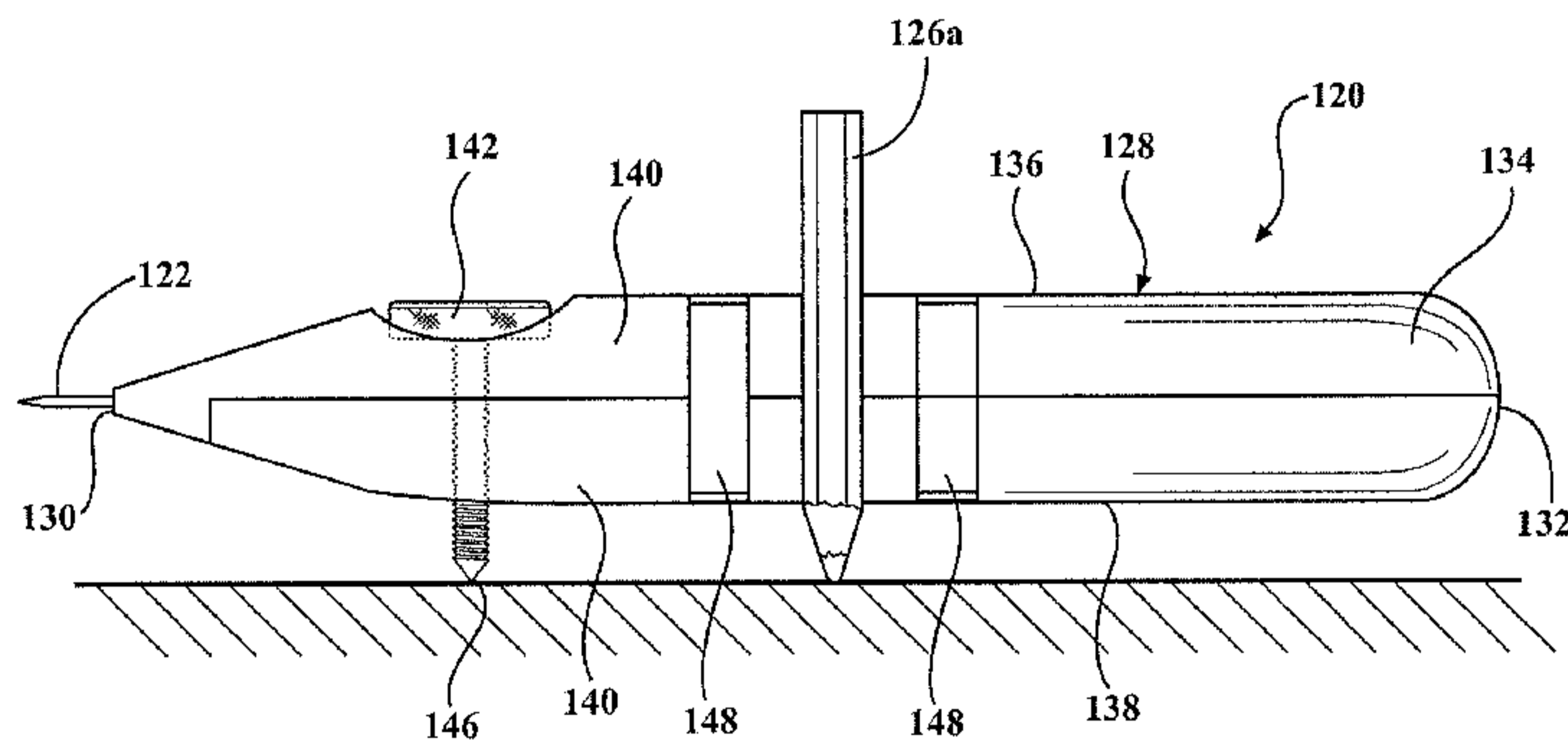

FIG. 6

(57) Abstract: An improved multi-tool assembly (20) which includes a housing (28) that extends between opposing first and second longitudinal ends is provided. The multi-tool assembly further includes a blade (22) which is partially disposed within the housing and which projects out of the first longitudinal end (30) of the housing. The housing has a slot (24) which opens to the second longitudinal end (32) of the housing and at least one tool engaging element (44) disposed at least partially within the slot of releasably securing a tool (26) in the slot at the second longitudinal end of the housing such that the tool projects out of the second longitudinal end of the housing.

WO 2015/048337 A1 

DK, EE, ES, FI, FR, GB, GR, HR, HU, IE, IS, IT, LT, **Published:**
LU, LV, MC, MK, MT, NL, NO, PL, PT, RO, RS, SE, — *with international search report (Art. 21(3))*
SI, SK, SM, TR), OAPI (BF, BJ, CF, CG, CI, CM, GA,
GN, GQ, GW, KM, ML, MR, NE, SN, TD, TG).

MULTI-TOOL ASSEMBLY

CROSS-REFERENCE TO RELATED APPLICATION

[0001] This application claims priority to U.S. Provisional Application No. 61/882,187, filed September 25, 2013 and to U.S. Provisional Application No. 61/946,095, filed February 28, 2014.

BACKGROUND OF THE INVENTION

1. Field of the Invention

[0002] The present invention is related to hand-held multi-tool assemblies.

2. Related Art

[0003] People who work with drywall often make patterns on drywall panels and then cut through the drywall along the drawn patterns. As such, most drywall workers carry both a pencil (or a pen or any other writing utensil) and a utility knife and regularly switch between these two tools. Such drywall workers may also carry additional tools including, for example, a Phillips or flat head screw driver and a drywall/jab saw. In addition to the time required to switch between these two or more objects, the repeated processes of taking out and putting away the utility knife with its sharp blade could potentially be dangerous.

SUMMARY OF THE INVENTION

[0004] An aspect of the present invention provides for an improved multi-tool assembly which includes a housing that extends between opposing first and second longitudinal ends. The multi-tool assembly further includes a blade which is partially disposed within the

housing and which projects out of the first longitudinal end of the housing. The housing has a slot which opens to the second longitudinal end of the housing and at least one tool engaging element disposed at least partially within the slot of releasably securing a tool in the slot at the second longitudinal end of the housing such that the tool projects out of the second longitudinal end of the housing.

[0005] The improved multi-tool assembly provides for significant efficiency and safety advantages. For example, a worker can switch between using the blade at the first longitudinal end to the tool on the second longitudinal end without having to put down or otherwise store any tools. This is particularly advantageous in the drywall industry where typical worker routinely switching between using writing utensils, such as carpenter's pencils, and utility knives. The process for switching between those two tools can be distracting and potentially dangerous if the worker accidentally makes contact with the blade. In contrast, with the improved multi-tool assembly, the worker can quickly and safely rotate the housing to switch between use of the carpenter's pencil and the blade.

[0006] Another aspect of the present invention provides for a multi-tool assembly including a housing which extends between first and second longitudinal ends and has a pair of sides and a back. The housing is made of two cover pieces which are joined together to present an open interior space between the cover pieces. A blade is partially disposed within the housing and projects out of the first longitudinal end through an opening formed between the cover pieces. At least one of the cover pieces of the housing presents a slot which opens to the second longitudinal end of the housing. A set screw extends through one of the sides of the housing and into the slot for releasably engaging a tool in the slot. The two cover pieces of the housing are joined together with a screw which extends past the housing to a point. The housing further

includes at least one recess which is spaced longitudinally from the screw and is shaped to receive a writing utensil and to hold the writing utensil in a direction that is generally parallel to the screw for drawing circular shapes by spinning the housing around the point of the screw.

BRIEF DESCRIPTION OF THE DRAWINGS

[0007] These and other features and advantages of the present invention will be readily appreciated, as the same becomes better understood by reference to the following detailed description when considered in connection with the accompanying drawings wherein:

[0008] Figure 1 perspective view of a first exemplary embodiment of a multi-tool assembly with a carpenter's pencil received therein;

[0009] Figure 2 is a front elevation view of the first exemplary embodiment of the multi-tool assembly;

[0010] Figure 3 is a cross-sectional view of the first exemplary embodiment of the multi-tool assembly taken along line 3-3 of Figure 2;

[0011] Figure 4 is a perspective view of the first exemplary embodiment of the multi-tool assembly and with a saw received therein;

[0012] Figure 5 is a perspective view of a second exemplary embodiment of the multi-tool assembly;

[0013] Figure 6 is a side elevation view of the second exemplary embodiment of the multi-tool assembly in use drawing a circle; and

[0014] Figure 7 is a front elevation view of a third exemplary embodiment of the multi-tool assembly and with a carpenter's pencil received therein.

DESCRIPTION OF THE ENABLING EMBODIMENT

[0015] Referring to the Figures, wherein like numerals indicate corresponding parts throughout the several views, a first exemplary embodiment of an improved hand-held multi-tool assembly **20** is generally shown in Figure 1. The multi-tool assembly **20** includes a knife or blade **22** at one longitudinal end for cutting objects (such as drywall) and a slot **24** for receiving a secondary tool **26**, such as a carpenter's pencil **26a** (shown in Figure 1) or a saw **26b** (shown in Figure 4), on the other longitudinal end. The multi-tool assembly **20** provides for substantial efficiency advantages since it allows a worker to conveniently perform different operations without taking his or her eyes off of the object being worked on to put down his or her utility knife and pick up a different tool. Moreover, the blade **22** and the secondary tool **26** are specifically positioned on the multi-tool assembly **20** such that it is very easy for a user to switch between which tool is being used, i.e., a worker can very easily switch between using the secondary tool **26** and the blade **22**.

[0016] Referring now to Figures 2 and 3, the first exemplary embodiment of the multi-tool assembly **20** includes a housing **28** which is generally rectangular in shape and extends in a longitudinal direction between opposite first and second longitudinal ends **30**, **32**. The housing **28** also has a pair of lateral sides **34**, a front **36** and a back **38**. As shown, the housing **28** includes two cover pieces **40** which are formed separately and are joined together via a screw **42** which extends between the cover pieces **40**. When the cover pieces **40** are attached together, the housing **28** presents an open interior between the cover pieces **40**. The cover pieces **40** may be made of any suitable material including, for example, plastic, nylon, metal, etc. The cover pieces **40** may be formed through any suitable process including, for example, injection molding.

[0017] The blade **22** is at least partially disposed within the open interior of the housing **28** and extends through the first longitudinal end **30** to allow the multi-tool assembly **20** to be used as a utility knife. Replacement blades **22** may conveniently be stored in the open interior of the housing **28** for use after the blade **22** dulls.

[0018] On the opposite longitudinal end from the blade **22**, the housing **28** has a slot **24** which is open to the second longitudinal end **32** for receiving a secondary tool **26**. As shown in Figure 3, in the first exemplary embodiment, the slot **24** is integrally formed entirely within one of the cover pieces **40** of the housing **28**. As also shown in Figure 3, the exemplary slot **24** has an eight sided shape when viewed in cross-section with two of the opposite sides being longer than the other six sides such that the slot **24** is configured for receiving a standard carpenter's pencil **26a**, as shown in Figure 1. With a carpenter's pencil **26a** received within the slot **24**, this allows for new and expected results, particularly in the field of drywall work. Specifically, such a drywall worker can use the carpenter's pencil **26a** on the one longitudinal end of the multi-tool assembly **20** to draw a pattern and can then flip the multi-tool assembly **20** around to make a cut along that pattern with the blade **22**. This is far more efficient than using a pencil, putting down the pencil, finding a utility knife, picking up the utility knife and then cutting the pattern which was drawn with the pencil. Additionally, other types of secondary tools **26** can be placed in the slot **24** including, for example, a saw **26** (as shown in Figure 4) or a Phillips head or flat head screwdriver. Preferably, each of the tools has a portion that is shaped similarly to the slot **24** to provide a very secure connection between the respective tool and the slot **24**. The slot **24** also preferably extends approximately halfway between the longitudinal ends **30**, **32** of the housing **28**. This provides for a very secure connection between the secondary

tool **26** and the housing **28** with very little slop, thus allowing for increased precision when using the secondary tool **26**.

[0019] The multi-tool assembly **20** further includes at least one tool engaging element **44** for releasably securing the carpenter's pencil **26a** or other secondary tool **26** within the slot **24**. In the exemplary embodiment, the tool engaging element **44** is a set screw **44** which extends through one of the sides of the housing **28**. Threading the set screw **44** in one direction tightens the engagement with the secondary tool **26** by pressing the set screw **44** against the secondary tool **26**, and threading the set screw **44** in the opposite direction releases the engagement with the secondary tool **26** to allow for replacement of the secondary tool **26**. Figure 3 shows the set screw **44** threaded into an engaged position in contact with a contractor's pencil **26a**. In the exemplary embodiment, the set screw **44** has an oversized head to allow a user to manually thread the set screw **44** by hand and without any special tools. For use with a carpenter's pencil **26a**, this is particularly advantageous because it allows the position of the carpenter's pencil **26a** within the slot **24** to be quickly adjusted in response to wearing of the carpenter's pencil **26a**.

[0020] Referring now to Figures 5 and 6, a second exemplary embodiment of the multi-tool assembly **120** is generally shown with like numerals, separated by a factor of, indicating corresponding parts with the first exemplary embodiment described above. The second exemplary embodiment is similar to the first exemplary embodiment described above, but is further configured to hold a pencil in a different way (other than with the above-discussed slot **24**) for drawing circles. Specifically, the screw **142** which joins the two cover pieces **140** of the housing **128** together extends through the housing **128** and presents a point **146** for placing on a surface and rotating the housing **128** thereabout, and the housing **128** further includes a

plurality of recesses **148** for releasably holding the pencil. The recesses **148** are formed into one of the sides of the housing **128** and are spaced longitudinally from one another and from the screw **142** by predetermined distances, such as one half of an inch (1/2") between adjacent recesses **148**. Each of the recesses **148** is sized for frictionally holding a carpenter's pencil **126a** in a direction parallel to the screw **142** and perpendicularly to the front **136** and back **138** of the housing **128**. For example, Figure 5 shows the carpenter's pencil **126a** being held in one of the recesses **148** and showing the point **146** of the screw **142** engaging a surface for rotating the housing **128** about the point **146** to draw the circle with the carpenter's pencil **126a**. This feature is particularly advantageous because a worker may very quickly draw a circle with a predetermined diameter (determined by which slot **124** the carpenter's pencil **126a** is inserted) and then use the blade **122** in the utility knife assembly to cut along that pattern. Cutting circular patterns are particularly common in the drywall industry, and thus, this exemplary embodiment is particularly suited for drywall workers.

[0021] Referring now to Figure 7, a third exemplary embodiment of the multi-tool assembly **220** is generally shown with like numerals, separated by a factor of, indicating corresponding parts with the first and second exemplary embodiments described above. This embodiment is distinguished from the first exemplary embodiment described above by the slot **224** for receiving the secondary tool **226** being a longitudinally extending groove formed into the front **236** of the housing **228** and extending to the second longitudinal end **232** and by the tool engaging element **244** being a plurality of generally triangular teeth **244** for biting into a carpenter's pencil **226a** and releasably securing the carpenter's pencil **226a** with the housing **228**. In this embodiment, the carpenter's pencil **226a** may be pressed into the groove from the front **236** of the housing **228** so that the teeth **244** engage into the sides of the pencil. The

positioning of the carpenter's pencil **226a** may also be adjusted by removing it and repositioning it within the slot **224**.

[0022] Referring back to Figures 5 and 6, another aspect of the present invention provides for a method of making a circular pattern on a surface. The method includes the step of providing a multi-tool assembly **120** which includes a housing **128** which extends between opposite first and second longitudinal ends **130, 132** and includes a blade **122** which projects out of the first longitudinal end **130** and a screw **142** which extends through the housing **128** and projects outwardly therefrom at a point **146** and wherein the housing **128** has at least one recess **148** formed in a side thereof which is spaced longitudinally from the screw **142**. The method continues with the step of positioning a writing utensil, such as a carpenter's pencil **126a**, having a tip within the recess **148** of the housing **128**. The method proceeds with the step of placing the point **146** of the screw **142** and the tip of the writing utensil in contact with a surface. The method continues with the step of rotating the housing **128** of the multi-tool assembly **120** about the point **146** of the screw **142** to rotating the housing **128** of the multi-tool assembly **120** about the point **146** of the screw **142** to draw a circular pattern on the surface with the writing utensil.

[0023] Obviously, many modifications and variations of the present invention are possible in light of the above teachings and may be practiced otherwise than as specifically described while within the scope of the appended claims.

CLAIMS

What is claimed is:

1. A multi-tool assembly, comprising:
a housing which extends between opposing first and second longitudinal ends;
a blade that is partially disposed within said housing and which projects out of said first longitudinal end of said housing;
said housing having a slot which opens to said second longitudinal end of said housing;
and
at least one tool engaging element disposed at least partially within said slot for releasably securing a tool in said slot at said second longitudinal end of said housing such that the tool projects out of said second longitudinal end.
2. The multi-tool assembly as set forth in claim 1 further including a pencil and wherein said at least one tool engaging element secures said pencil within said slot.
3. The multi-tool assembly as set forth in claim 1 wherein said housing includes a pair of cover pieces that are joined with one another;
4. The multi-tool assembly as set forth in claim 3 wherein said cover pieces are joined together with a screw.

5. The multi-tool assembly as set forth in claim 4 wherein said screw extends through said housing and projects therefrom with a point for rotating said housing about said point.

6. The multi-tool assembly as set forth in claim 5 wherein said housing further includes a plurality of recesses that are spaced longitudinally from one another and from said screw for holding a writing utensil in a direction parallel to said screw for drawing circles about around said screw.

7. The multi-tool assembly as set forth in claim 1 wherein said tool engaging element is a set screw.

8. The multi-tool assembly as set forth in claim 7 wherein said set screw has an enlarged head for manual threading and unthreading by hand.

9. A multi-tool assembly, comprising:
a housing which extends between opposing first and second longitudinal ends, said housing having a pair of sides and a front and a back, said housing being made of two cover pieces which are fixed together, and said housing presenting an open interior between said cover pieces;
a blade that is partially disposed within said housing and which projects out of said first longitudinal end through an opening formed between said cover pieces;

at least one of said cover pieces of said housing presenting a slot which opens to said second longitudinal end of said housing;

a tool engaging element which extends through one of said sides of said housing and into said slot for releasably engaging a tool in said slot;

said housing including a screw joining said cover pieces of said housing together and extending past said housing to a point; and

said housing presenting at least one recess which is spaced longitudinally from said screw by a predetermined distance, said recesses being shaped to receive a writing utensil and hold the writing utensil in a direction that is generally parallel to said screw for drawing circular shapes by spinning said housing around said point of said screw.

10. The multi-tool assembly as set forth in claim 9 and wherein said at least one recess in said housing is further defined as a plurality of recess which are spaced longitudinally from one another by predetermined distances.

11. The multi-tool assembly as set forth in claim 9 wherein said tool engaging element is a set screw.

12. The multi-tool assembly as set forth in claim 9 wherein said at least one recess is shaped to receive a carpenter's pencil.

13. A method of making a circular pattern on a surface;

providing a multi-tool assembly including a housing which extends between opposite first and second longitudinal ends and a blade which projects out of the first longitudinal end and a screw which extends through the housing and projects outwardly therefrom at a point and wherein the housing has at least one recess formed in a side thereof which is spaced longitudinally from the screw;

positioning a writing utensil having a tip within the recess in the housing;

placing the point of the screw and the tip of the writing utensil in contact with a surface;

and

rotating the housing of the multi-tool assembly about the point of the screw to draw a circular pattern on the surface with the writing utensil.

14. The method as set forth in claim 13 wherein the writing utensil is a carpenter's pencil.

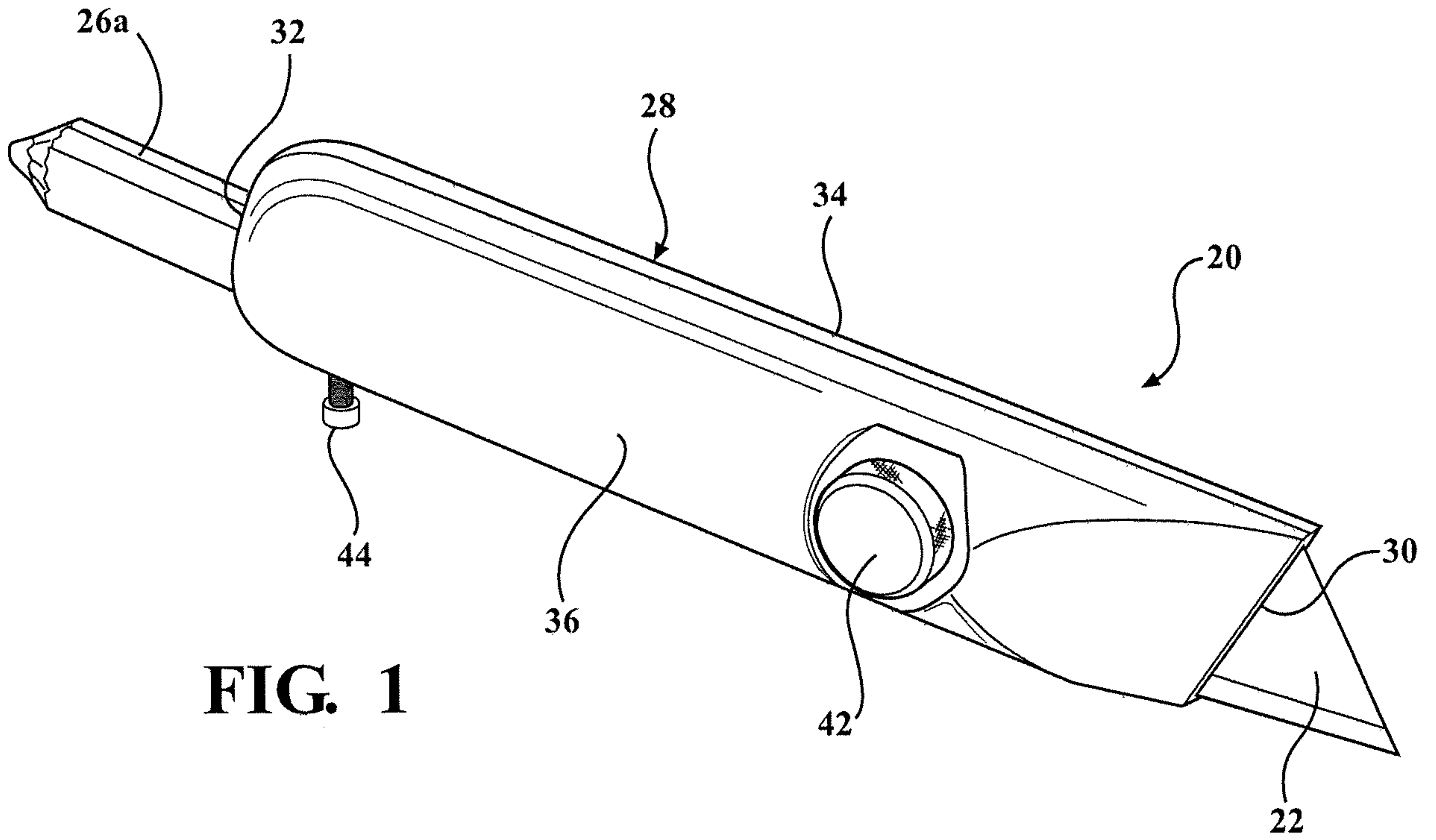

FIG. 1

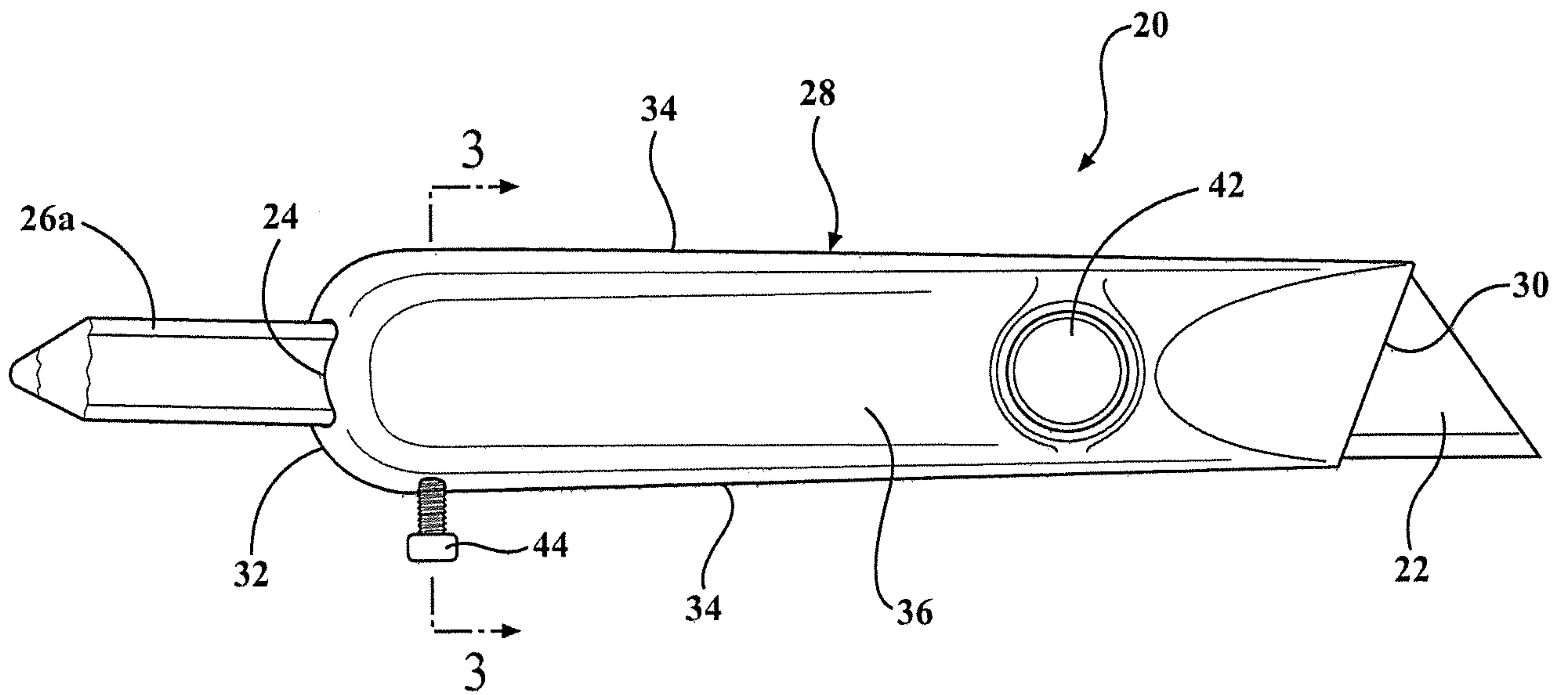

FIG. 2

FIG. 3

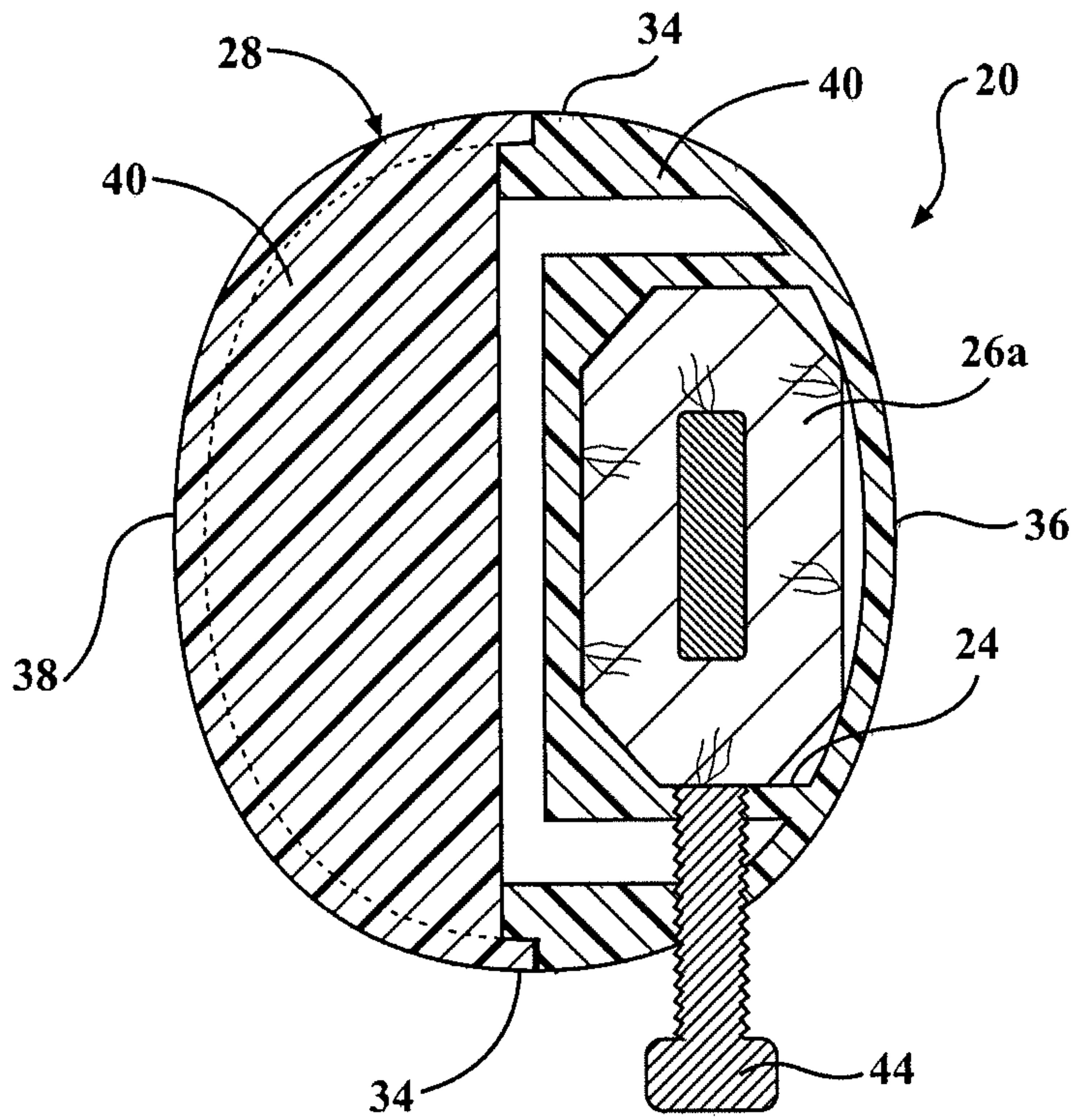

FIG. 4

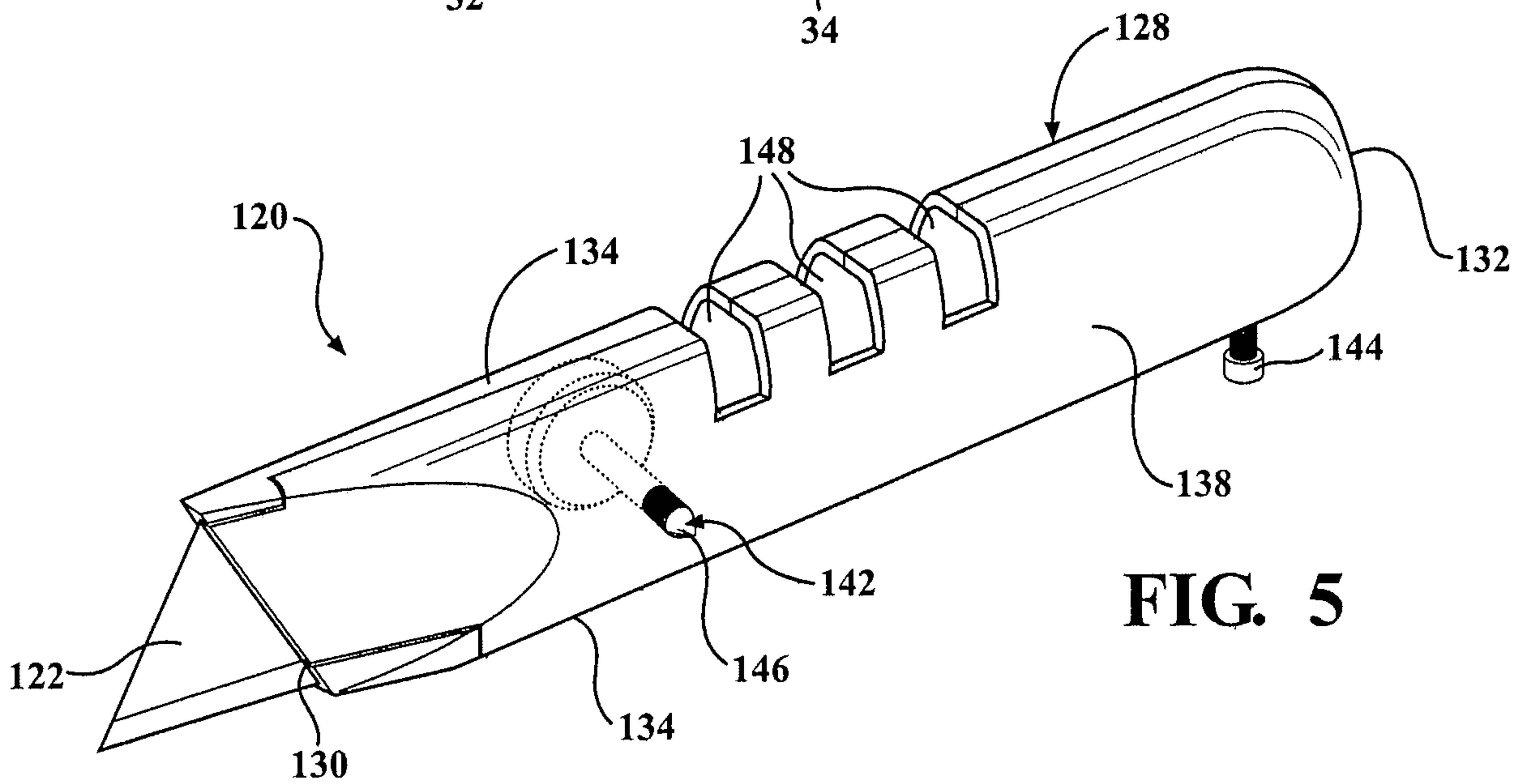
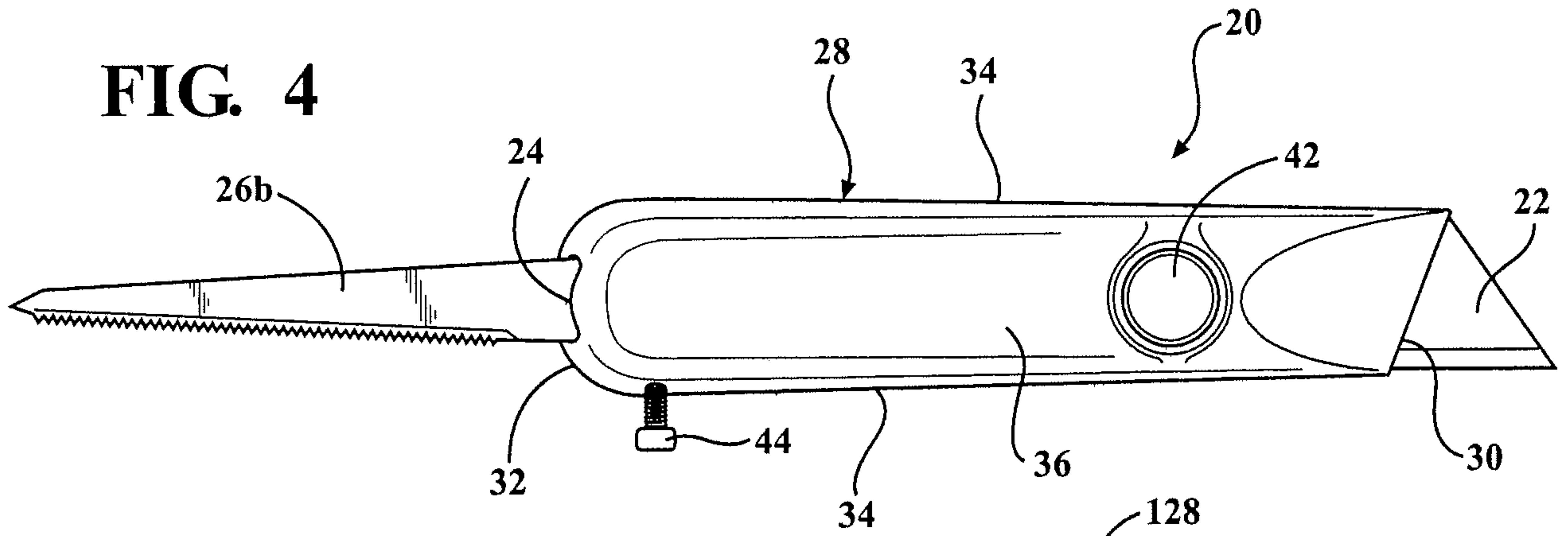

FIG. 5

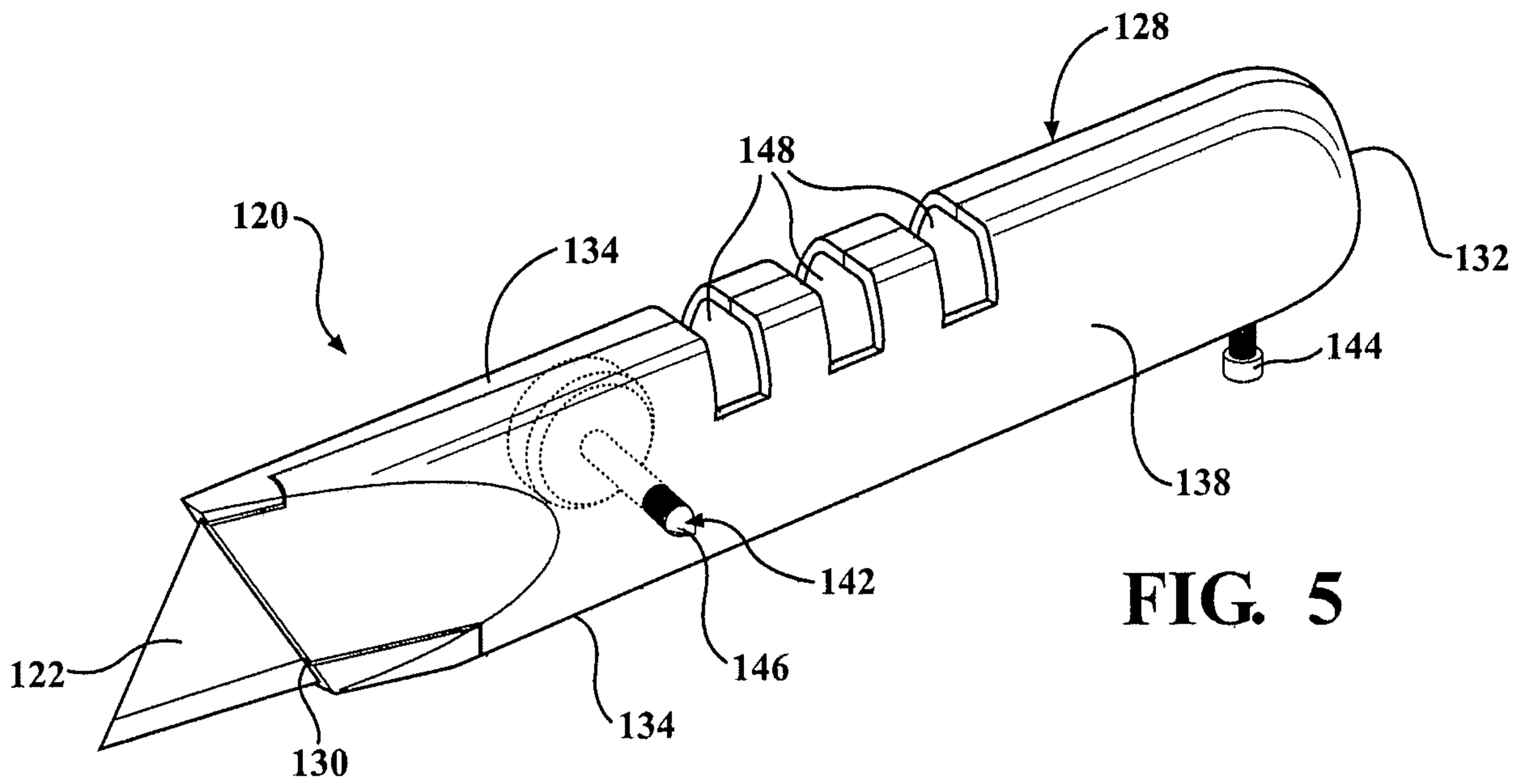

FIG. 5

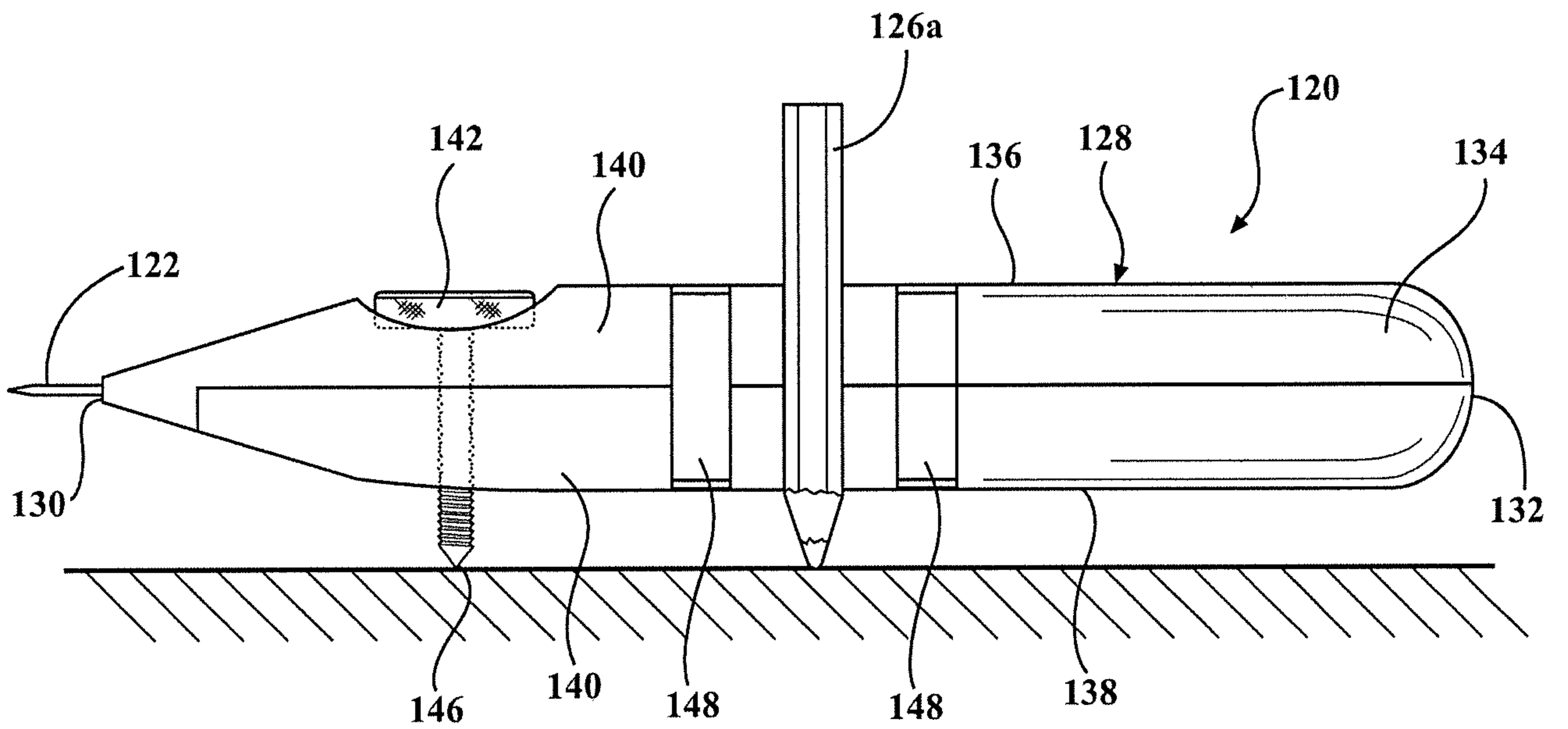

FIG. 6