

J. H. RUSK.
GRINDING MILL.

No. 110,397.

Patented Dec. 20, 1870.

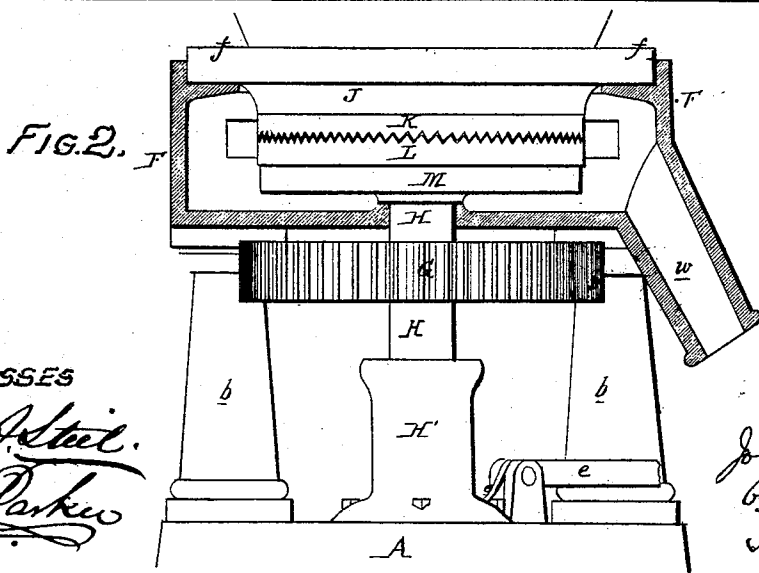
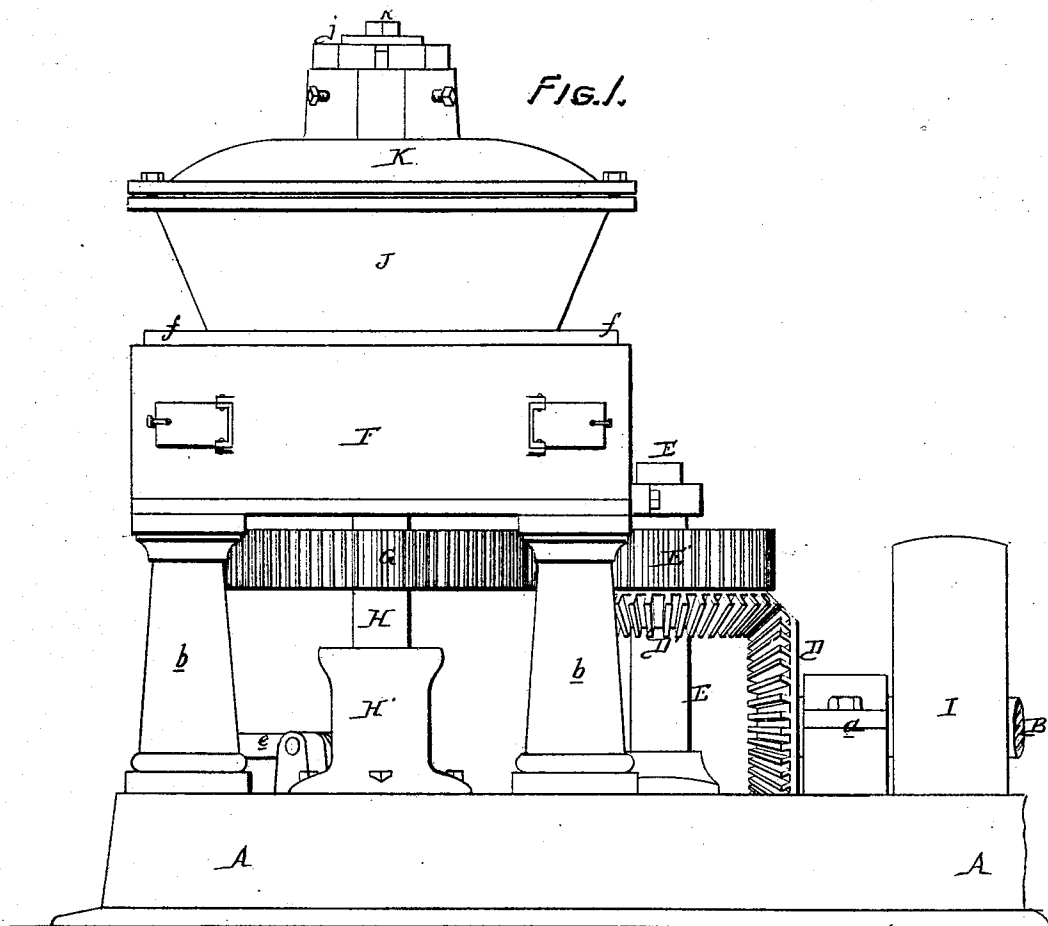

WITNESSES
Wm. A. Steel.
John Parker

John H. Rusk
 by his Atty.
Howard Austin

J. H. RUSK.
GRINDING MILL.

No. 110,397.

Patented Dec. 20, 1870.

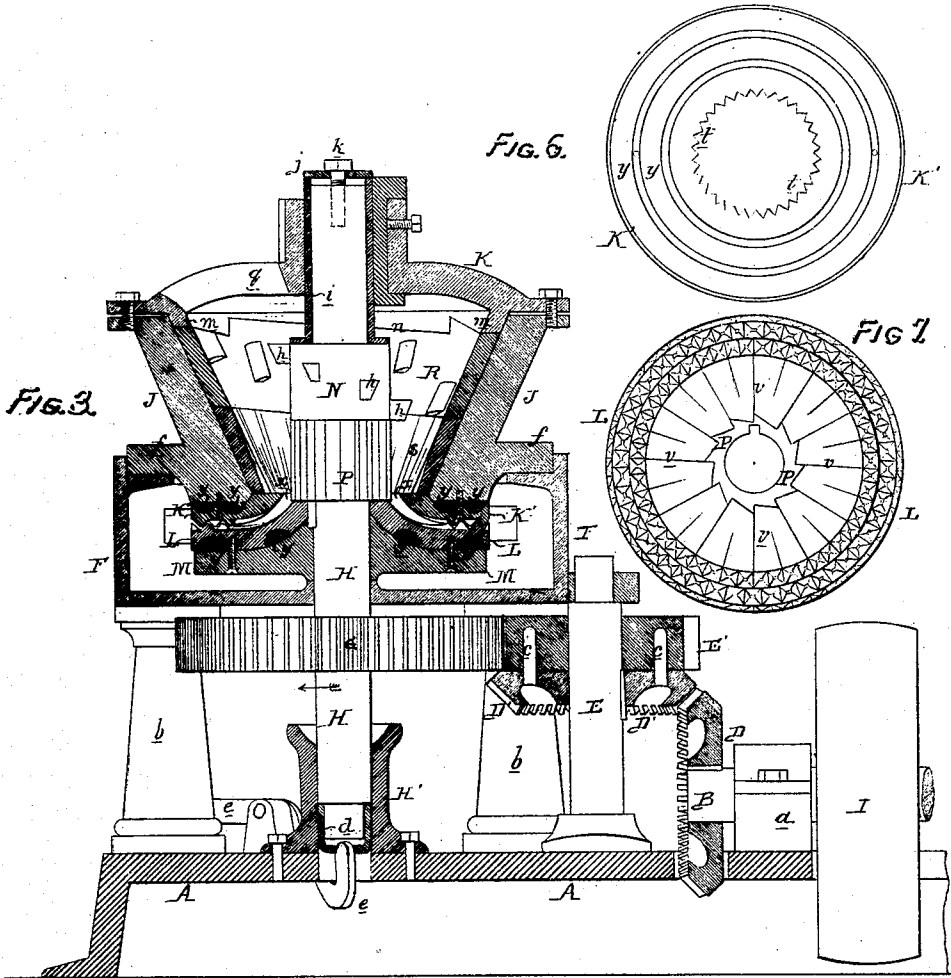

Fig. 6.

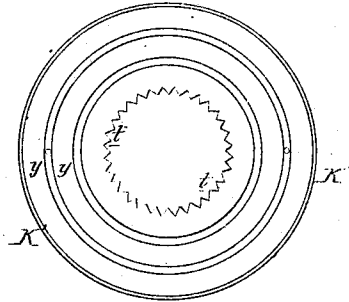

Fig. 7.

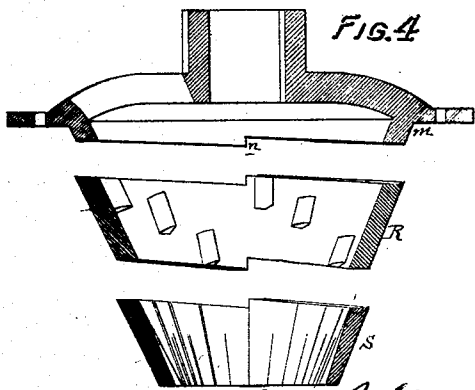
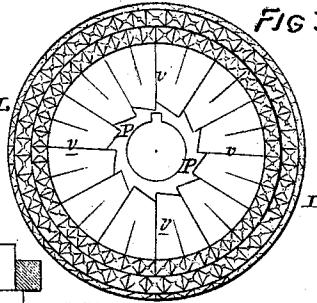

Fig. 4.

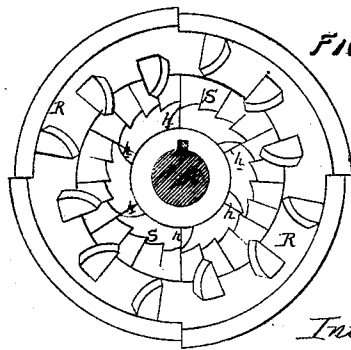

Fig. 5.

WITNESSES { *Wm. Abbott*
John Parker

Inventor
John H. Rusk
by his Attor
Howson and son

United States Patent Office

JOHN H. RUSK, OF PHILADELPHIA, PENNSYLVANIA.

Letters Patent No. 110,397, dated December 20, 1870; antedated December 9, 1870.

IMPROVEMENT IN GRINDING-MILLS.

The Schedule referred to in these Letters Patent and making part of the same.

I, JOHN H. RUSK, of Philadelphia, county of Philadelphia, State of Pennsylvania, have invented certain Improvements in Grinding-Mills, of which the following is a specification

Nature and Object of the Invention.

My invention consists of certain Improvements in Grinding-Mills fully described hereafter, whereby the construction of the mill is simplified, the fitting of the parts together facilitated, and the mill rendered more efficient in operation, more durable, and less liable to get out of order than those of the usual construction.

Description of Accompanying Drawing.

Figure 1 (drawing No. 1) is a side view of my improved grinding-mill;

Figure 2, an end view, partly in section;

Figure 3, (drawing No. 2,) a sectional elevation;

Figure 4, a sectional view of the inner shell and cover detached from each other;

Figure 5, a plan view of the inner shell.

Figure 6, a plan view, showing the upper surface of the intermediate grinding-plate; and

Figure 7, a plan view, showing the upper surface of the lowest grinding-plate.

General Description.

A represents the foundation-plate of the mill; and in suitable bearings *a* on this plate turns the horizontal driving-shaft B, the latter carrying a bevel-wheel, D, gearing into a bevel-wheel, D', on a vertical shaft, E, which turns below in the foundation-plate A and above in a projection from the hollow base F of the mill, the latter being connected to the foundation-plate by suitable columns *b b*.

Above the bevel-wheel D' and adapted to the vertical shaft E is a pinion, E', gearing into the cog-wheel G on the mill-spindle H.

It may be remarked here that while the bevel-wheel D' is keyed or otherwise secured to the shaft E, the pinion E' is loose thereon, but is connected to the wheel D' by pins *c c* of such metal or alloy and of such strength that, while they will serve as mediums for transmitting from the driving-shaft to the mill-spindle power sufficient for all ordinary grinding purposes, the pins will yield should a piece of iron gain access to the mill, or should the latter be subjected to any excessive strain which might impair its integrity, the pins thus acting as safety mediums for preventing accidents.

It will be evident that the bevel-wheel D' may be loose and the wheel E' fast on the shaft, or the driving-pulley I may be situated close to the bevel-wheel D, the latter being loose on the shaft B, and the two being coupled together by safety-pins *c c*, which I, how-

ever, prefer to arrange in the manner illustrated in fig. 1 and described above.

The lower end of the mill-spindle H turns in a foot-step, H', secured to the foundation-plate A, the extreme lower end of the spindle turning in and being supported by a cup, *d*, so adapted to the foot-step as to both slide and turn freely therein, and having on its under side a conical recess adapted to the bent end of a lever, *e*, which projects through a slot in the foot-step, and which is hung to a projection on the foundation-plate.

J is the outer shell of the mill, having a flange, *f*, adapted to a recess in the hollow base F, and secured to the latter, a flanged cover or bridge, K, being secured to the upper edge of the outer shell, to the lower edge of which is attached, by simple pins, the intermediate grinding-plate K'; and beneath the latter the lower grinding-plate L rests on, and is attached, by pins, to a disk, M, which is secured to or forms a part of the mill-spindle H, the latter being provided with two burs, N and P, and the upper bur, N, having breaking-teeth or projections, *h*, and the lower bur vertical teeth, of the form illustrated in fig. 7.

Both burs have grooves adapted to a permanent key or feather on the mill-spindle, and both are confined to the intermediate grinding-plate L by a sleeve, *i*, on the top of which bears a disk or washer, *j*, confined to the mill-spindle by a set-screw or bolt, *k*, the sleeve being adapted to and arranged to revolve (with the spindle) in a suitable bearing in the cover or bridge K.

A flange, *m*, on the under side of this cover, fits snugly within the outer shell J, as also do the two conical grinding sections R and S, which form the inner shell of the mill.

Four inclined planes, *n*, are formed on the under side of the flange *m*, as will be best observed on reference to fig. 4, and corresponding planes are formed on the upper edge of the section R of the shell, the lower edge of which has inclined planes corresponding with similar planes on the upper edge of the section of the shell.

When the sections have been fitted to the outer shell and the cover K secured to the same, and the mill-spindle be turned in the direction of the arrow, fig. 3, the tendency of the burs and the material acted on by them will be to turn the two sections R and S in the same direction, but this will be resisted by the inclined planes above mentioned, which will tend to render the sections self-locking to the outer shell, within which the said sections will be too tightly jammed to need further fastenings.

The material to be ground, after being introduced to the mill through the opening *g* in the cover, is first acted on by the coarse teeth of the upper section B

of the inner shell and those of the bur N, after which it is further broken and granulated by the fine teeth of the lower section S, and those of the lower bur P, until the material is in a condition to enter the space x between the intermediate grinding-plate K' and the lower grinding-plate L.

As the material enters this space, however, it is still further triturated by the teeth t on the edge of the opening of the plate K', fig. 6, and those of the lower bur.

After gaining access to the space between the plates K' and L the granulated material passes first downward and then horizontally, until it is finally discharged from between the plates (after being thoroughly pulverized by the same) into the interior of the hollow base F, from which it may be directed by a suitable arm or scraper to the spout w , fig. 2.

The dress of these grinding-plates K' and L may be modified to suit the character of the material to be ground.

If the material possesses the toughness or hardness of bones or quartz, I prefer the dress illustrated in fig. 7, where it will be observed that the dress consists of radial teeth, v , terminating near the edge in pointed or chisel-shaped teeth. Care should be taken, however, that the points of the teeth of one plate should coincide with the circular recesses between the pointed teeth of the other plate, as shown in fig. 3.

It is essential that the cast-iron of which the plates K' and L are made should be of a very hard quality, and that the fitting of the plate K' to the lower edge of the outer shell, and that of the lower plate L to the disk M, should be as accurate as possible; otherwise frequent fractures of the plates must occur, and the necessary hardness of the metal precludes the use of ordinary tools for producing accurate fits.

In order to overcome this difficulty I cast in the upper face of the plate K' one, two, or more annular recesses, and having filled these with comparatively soft metal or alloy, y , (Babbitt metal, for instance,) I face the same in a lathe, so that it may fit accurately to the turned surface of the under edge of the outer shell J, with which the hard metal of the plate may be free from contact.

In like manner the soft metal y in the recesses of the under plate L is faced, so that it may fit accurately to the disk M.

My improved grinding-mill is peculiarly constructed, and its parts so arranged as to permit the ready removal of those operating portions which are most liable to rapid deterioration.

On removing the cover K, for instance, the two sections R and S can be at once withdrawn, as, also, can the burs N and P, after simply withdrawing the set-screw k and sleeve i .

Should it be necessary to gain access to or remove the plates K' and L, (and this is not frequently re-

quired,) the outer shell J must be detached from the hollow base B with the cover-burs, and sections R and S, leaving behind the two plates K' and L, which can be withdrawn through the opening in the top of the hollow base without disturbing the mill-spindle H, or its disk M, for it should be understood that the plate K' is connected to the outer shell J by simple pins only, to prevent the former from turning, and that the plate L is connected to the disk M with like pins, so that one must turn with the other, although the pins will not interfere with the rising of one independently of the other.

It will be evident that an inner lining made in one piece may be confined to and rendered self-locking within an outer shell in the manner described, or that the inner grinding-shell may be composed of more than two sections, and made self-locking, as described; also, that recesses may be formed in the exterior of the linings or sections, and filled with soft metal, so as to insure a true fit to the interior of the outer shell in the same manner as I have described in reference to the fitting of the plates K' and L; but this mode of fitting is more important when employed in connection with the latter plates than with the above-mentioned sections.

While the foot-step H' affords a steady bearing laterally for the lower end of the mill-spindle, the latter is under the control (vertically) of the lever e , on which rests the cup d , for supporting the shaft and for receiving the lubricating material.

Claims.

1. The combination, substantially as described, of soft-metal pins or plugs e with the driving-gear of a grinding-mill.

2. The detachable lining or inner shell, composed of one or more sections, adapted to and rendered self-locking in the outer conical shell of a grinding-mill by inclined planes on the cover or bridge of the mill, and similar inclined planes on the section or sections, all substantially in the manner described.

3. The detachable sections, having at their backs recesses filled with soft metal, as set forth.

4. The combination of the rotating spindle H, its burs P N, cross-piece K, sleeve i extending through said cross-piece, and set-screw k , substantially as described.

5. The outer shell or casing J, receiving the detachable sections R S, and sustaining the section K, as specified.

In testimony whereof I have signed my name to this specification in the presence of two subscribing witnesses.

JOHN H. RUSK.

Witnesses:

JOHN WHITE,
LOUIS BOSWELL.