

CHARLES ROBB.

Self-Sustaining Gas-Bracket, Etc.

No. 127,798.

Patented June 11, 1872.

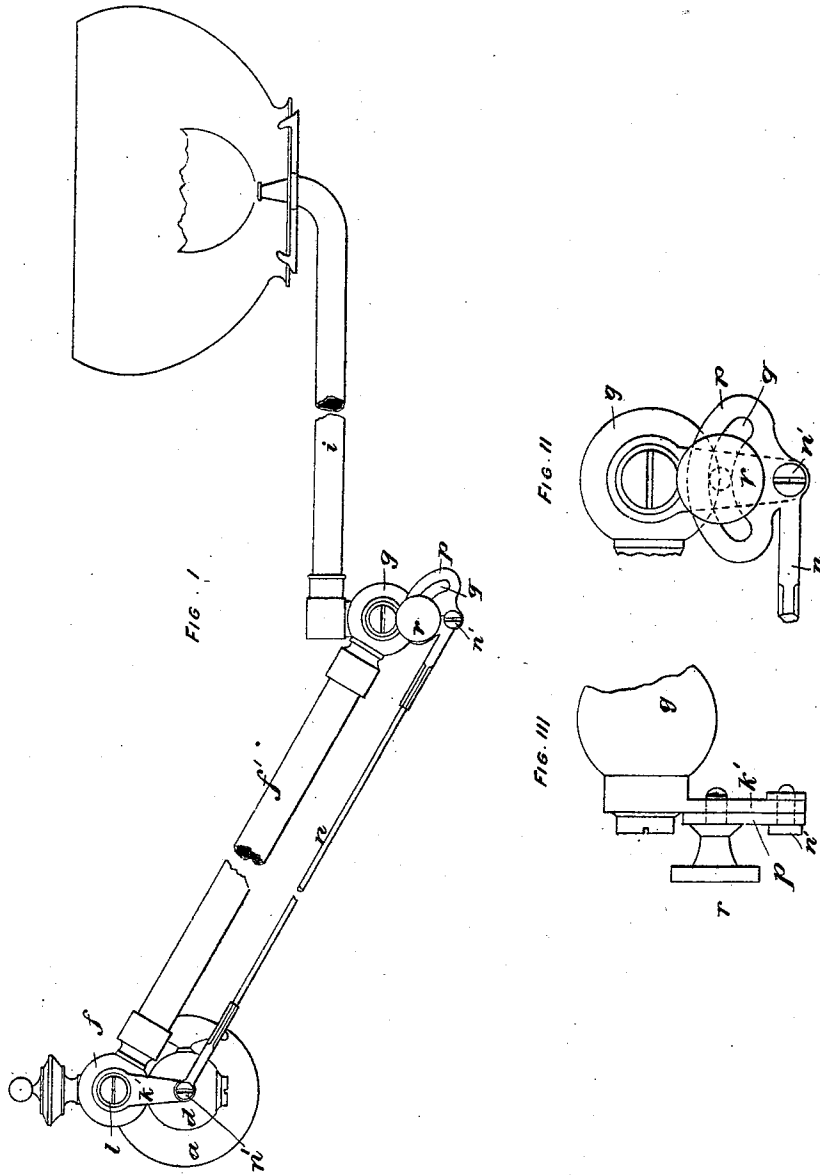

Witnesses
Harrie Leblanc
Chas. & Chisney

Inventor
Chas. Robb by
H. W. Beadle
Associate
att'y

UNITED STATES PATENT OFFICE.

CHARLES ROBB, OF MONTREAL, CANADA.

IMPROVEMENT IN SELF-SUSTAINING GAS-BRACKETS, LAMP-STANDS, &c.

Specification forming part of Letters Patent No. 127,798, dated June 11, 1872.

SPECIFICATION.

To all whom it may concern:

Be it known that I, CHARLES ROBB, of the city of Montreal, in the district of Montreal, in the Province of Quebec, Canada, have invented new and useful Improvements in Self-Sustaining Gas-Brackets, Lamp-Stands, Shelves, &c.; and I do hereby declare that the following is a full, clear, and exact description of the construction and operation of the same, reference being had to the annexed drawing, where—

Figure I represents an elevation of my improved parallel motion. Fig. II represents an enlarged view of joint. Fig. III represents an enlarged end view of joint.

This invention has reference to improvements in devices for giving parallel motion to gas-brackets, lamp-stands, shelves, &c., for rendering them more practical for ordinary use, and capable of supporting heavy weights.

In the drawing hereunto annexed similar letters of reference indicate like parts.

Letter *a* is the ordinary plate for attaching the bracket to a wall, &c. This is made in one with a washer having another washer and keys, all constructed and arranged as in the ordinary manner for a universal joint. To these the washer *f* is fitted in the ordinary manner, and to this is attached the first limb *f'* of the gas-bracket, the other end of which terminates in the washer *g*, from which is carried in the usual way, by means of washers and keys, the outer limb *i*.

The whole of the above, as described, is fitted in the ordinary manner of gas-fitting work for universal joints, and in the form clearly shown in the drawing.

The parallelism is applied by securing to

the end of the key in the washer *d* a crank or arm, *k'*, by means of a screw, *l*. By this arrangement the arm *k'* is rigidly secured to the double key. *n* is a rigid rod provided with a double eye, connecting by means of pins *n'*, with the arm *k'*, and having its double eye at its other end provided with a flange, *p*. This flange is provided with a slot, *q*, as shown in the drawing. Corresponding with the slot a small screwed hole is made in the arm *k'* for the reception of a thumb or other screw, *r*, of any suitable form, by which the two are drawn together, giving the necessary friction; or they may be firmly cramped together, if desired. It will now be found that the articles supported on the outer limb *i* may be moved up and down and sidewise freely, at pleasure, within the limits for which the invention is constructed, the outer limb *i* at all times retaining its proper relative position, and being capable of supporting heavy weights. In Fig. I my invention is shown as applied to the outer end of the limb, but it may, if desired, be applied to the inner end, or to both.

I do not claim, broadly, the employment of parallel tubes with revolving joints, for this feature, &c., I know is old; but—

Having now described the construction and operation of my invention, what I claim, and wish to secure by Letters Patent, is as follows:

The rod *n* provided with flange *p* and slot *q* at one or both of its extremities, in combination with the cranks or arms *k'*, and thumb or other screws *r*, substantially as and for the purposes described.

Montreal, 19th day of January, A. D. 1871.

Witnesses: CHARLES ROBB.

CHARLES G. C. SIMPSON,
TRAS. HY. REYNOLDS.