

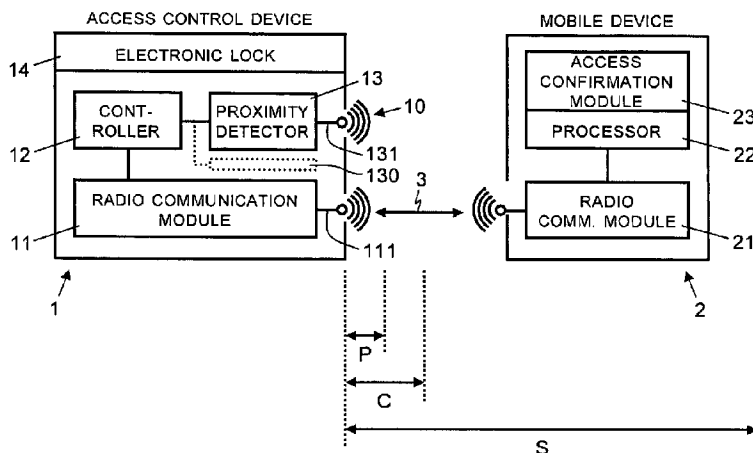

(86) Date de dépôt PCT/PCT Filing Date: 2015/06/18
 (87) Date publication PCT/PCT Publication Date: 2015/12/30
 (45) Date de délivrance/Issue Date: 2022/06/21
 (85) Entrée phase nationale/National Entry: 2016/11/07
 (86) N° demande PCT/PCT Application No.: EP 2015/001231
 (87) N° publication PCT/PCT Publication No.: 2015/197177
 (30) Priorité/Priority: 2014/06/23 (CH951/14)

(51) Cl.Int./Int.Cl. *G07C 9/29* (2020.01),
E05B 47/00 (2006.01), *H04W 4/80* (2018.01),
H04W 84/20 (2009.01)
 (72) Inventeurs/Inventors:
PLUS, MARCEL, CH;
STUDERUS, PAUL, CH
 (73) Propriétaire/Owner:
LEGIC IDENTSYSTEMS AG, CH
 (74) Agent: LAVERY, DE BILLY, LLP

(54) Titre : DISPOSITIF DE COMMANDE D'ACCES ELECTRONIQUE ET PROCEDURE DE COMMANDE D'ACCES
 (54) Title: ELECTRONIC ACCESS CONTROL DEVICE AND ACCESS CONTROL METHOD



(57) **Abrégé/Abstract:**

An electronic access control device (1) comprises a radio communication module (11) for wireless data exchange in a first radio frequency band with a mobile device (2) over a direct wireless communication link (3). The access control device has a controller (12) connected to the wireless radio communication module for generating an access control signal using an access key received from the mobile device. The electronic access control device further comprises a proximity detector (13) for detecting a mobile device in defined proximity (P), using a radio frequency in a second radio frequency band, different from the first radio frequency band. The controller is connected to the proximity detector and controls the radio communication module to establish the direct wireless communication link with the mobile device, only if the mobile device is detected in defined proximity of the electronic access control device.

(12) INTERNATIONAL APPLICATION PUBLISHED UNDER THE PATENT COOPERATION TREATY (PCT)

(19) World Intellectual Property
Organization
International Bureau(10) International Publication Number
WO 2015/197177 A1(43) International Publication Date
30 December 2015 (30.12.2015)

- (51) International Patent Classification:
G07C 9/00 (2006.01)
- (21) International Application Number:
PCT/EP2015/001231
- (22) International Filing Date:
18 June 2015 (18.06.2015)
- (25) Filing Language: English
- (26) Publication Language: English
- (30) Priority Data:
951/14 23 June 2014 (23.06.2014) CH
- (71) Applicant: LEGIC IDENTSYSTEMS AG [CH/CH];
Binzackerstrasse 41, CH-8620 Wetzikon (CH).
- (72) Inventors: PLÜSS, Marcel; Heligeichstrasse 56, CH-8632
Tann (CH). STUDERUS, Paul; Hüblistrasse 78, CH-
8165 Oberweningen (CH).
- (74) Agent: RENTSCH PARTNER AG; Fraumünsterstrasse
9, Postfach 2441, 8022 Zürich (CH).
- (81) Designated States (unless otherwise indicated, for every
kind of national protection available): AE, AG, AL, AM,

AO, AT, AU, AZ, BA, BB, BG, BH, BN, BR, BW, BY,
BZ, CA, CH, CL, CN, CO, CR, CU, CZ, DE, DK, DM,
DO, DZ, EC, EE, EG, ES, FI, GB, GD, GE, GH, GM, GT,
HN, HR, HU, ID, IL, IN, IR, IS, JP, KE, KG, KN, KP, KR,
KZ, LA, LC, LK, LR, LS, LU, LY, MA, MD, ME, MG,
MK, MN, MW, MX, MY, MZ, NA, NG, NI, NO, NZ, OM,
PA, PE, PG, PH, PL, PT, QA, RO, RS, RU, RW, SA, SC,
SD, SE, SG, SK, SL, SM, ST, SV, SY, TH, TJ, TM, TN,
TR, TT, TZ, UA, UG, US, UZ, VC, VN, ZA, ZM, ZW.

- (84) Designated States (unless otherwise indicated, for every
kind of regional protection available): ARIPO (BW, GH,
GM, KE, LR, LS, MW, MZ, NA, RW, SD, SL, ST, SZ,
TZ, UG, ZM, ZW), Eurasian (AM, AZ, BY, KG, KZ, RU,
TJ, TM), European (AL, AT, BE, BG, CH, CY, CZ, DE,
DK, EE, ES, FI, FR, GB, GR, HR, HU, IE, IS, IT, LT, LU,
LV, MC, MK, MT, NL, NO, PL, PT, RO, RS, SE, SI, SK,
SM, TR), OAPI (BF, BJ, CF, CG, CI, CM, GA, GN, GQ,
GW, KM, ML, MR, NE, SN, TD, TG).

Published:

— with international search report (Art. 21(3))

(54) Title: ELECTRONIC ACCESS CONTROL DEVICE AND ACCESS CONTROL METHOD

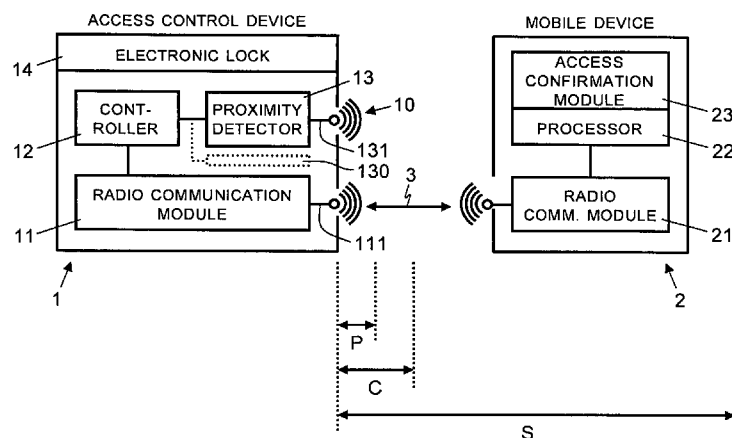

Fig. 1

(57) Abstract: An electronic access control device (1) comprises a radio communication module (11) for wireless data exchange in a first radio frequency band with a mobile device (2) over a direct wireless communication link (3). The access control device has a controller (12) connected to the wireless radio communication module for generating an access control signal using an access key received from the mobile device. The electronic access control device further comprises a proximity detector (13) for detecting a mobile device in defined proximity (P), using a radio frequency in a second radio frequency band, different from the first radio frequency band. The controller is connected to the proximity detector and controls the radio communication module to establish the direct wireless communication link with the mobile device, only if the mobile device is detected in defined proximity of the electronic access control device.



WO 2015/197177 A1

ELECTRONIC ACCESS CONTROL DEVICE AND ACCESS CONTROL METHOD

Field of the Invention

The present invention relates to an electronic access control device and an access control
5 method. Specifically, the present invention relates to an electronic access control device
comprising a radio communication module for a direct wireless data exchange with a
mobile device, and a controller connected to the wireless radio communication module
for generating an access control signal using an access key received from the mobile
device.

10 Background of the Invention

For many years, access control systems have been used in connection with passive RFID
transponders (Radio Frequency Identifier). These access control systems included RFID
readers for reading in a wireless fashion access rights or at least user identifiers from RFID
transponders to control access to an access controlled area, such as a building or a room,
15 or to access controlled objects, such as goods in a vending machine, etc. With the arrival
of mobile radio phones (cellular phones) that included active RFID-based communication
interfaces, so called NFC interfaces (Near Field Communication), it became possible to
use such mobile phones as carrier of access rights rather than passive RFID transponders
in form of RFID cards, dongles, or the like. With an NFC interface, it is possible to tie
20 access control to the physical presence of the mobile phone in an area that is near a
corresponding NFC interface of an access control device, e.g. attached to or close to a
door or a gate. In other words, the short communication range of NFC interfaces requires
that a user's mobile phone does not have to great a distance from the door or gate that is
to be accessed, making it unlikely that an unauthorized person gets given access
25 erroneously on the basis of access rights stored on the rightful user's mobile phone, as

long as the mobile phone is in the possession of the rightful user. However, not all types and brands of mobile phones are equipped with an NFC interface or other RFID-based communication capabilities. Nevertheless, in addition to the mobile radio communication modules used for accessing cellular telephone networks such as GSM (Global System for Mobile Communication) or UMTS (Universal Mobile Telephone System), some types and brands of mobile phones include other radio-based communication modules for establishing local or direct wireless communication links. For example, such radio-based communication modules include WLAN (Wireless Local Area Network) and Bluetooth communication interfaces which have a much larger communication range than NFC interfaces, e.g. ten to a hundred meters. Although such other radio-based communication modules could be used for exchanging access rights with an access control device, there is a risk that an unauthorized user could get erroneous access, only because the rightful user or at least his mobile phone is located within this extended communication range of the access control device.

FR 2981823 describes a method for authenticating identification device with respect to an actuator device integrated in car for carrying out car a start-up operation. In an authentication session, the identification device is authenticated by exchanging authentication data between the identification device and the actuator device. During an authentication session, a first part of the exchanging authentication data is communicated using Bluetooth, while a second part of the authentication data is exchanged through magnetic induction. In the actuator the two parts of authentication data are aggregated.

US 2012/154115 describes a method for controlling access in a location tracking system. When a mobile tag enters a room, it carries out location update procedures and becomes linked to a node of the location tracking system and updates its location in the

room. In response to the location update, a location tracking apparatus of the location tracking system transmits an activation signal to an access control apparatus in the room to initiate establishment of a communication connection with the mobile tag so as to negotiate about access rights of the mobile tag. In an embodiment, the access control apparatus may be provided with a proximity sensor which, subsequently to negotiating the access rights, detects the close proximity of the mobile tag, before the access control apparatus actually grants or denies access.

US 2014/049361 describes an electronic system which includes a mobile device that communicates with a reader device associated with an electronic lock. The mobile device and the reader device communicate with each other, e.g. via Bluetooth, and exchange credentials, secure data, and location information. In an embodiment, the electronic lock may also include a close proximity range capability which automatically unlocks the electronic lock when a mobile device with appropriate credentials is within the close proximity range.

15 Summary of the Invention

It is an object of this invention to provide an electronic access control device and an access control method that do not have at least some of the disadvantages of the prior art.

According to the present invention, these objects are achieved through the features of the independent claims. In addition, further advantageous embodiments follow from the dependent claims and the description.

An electronic access control device comprises a radio communication module and a controller connected to the wireless radio communication module. The radio

communication module is configured to perform a wireless data exchange in a first radio frequency band with a mobile device over a direct wireless communication link between the radio communication module and the mobile device. The controller is configured to generate an access control signal using an access key received by the radio communication module via the direct wireless communication link from the mobile device.

According to the present invention, the above-mentioned objects are particularly achieved in that the electronic access control device further comprises a proximity detector. The proximity detector is configured to detect a presence of a user of the mobile device in proximity of the electronic access control device not using a radio frequency in the first radio frequency band. The controller is connected to the proximity detector and further configured to control the radio communication module to establish the direct wireless communication link with the mobile device, upon detection of the presence of the user by the proximity, for enabling the mobile device to transmit the access key to the radio communication module.

In an embodiment, the proximity detector is a non-radio based proximity detector. The non-radio based proximity detector is configured to detect the presence of the user without using radio waves.

In an embodiment, the proximity detector comprises a shock detector connected to the controller and configured to generate an electrical signal indicative of detected mechanical shock. The controller is configured to detect a shock pattern from the electrical signal, and to control the radio communication module to establish the direct wireless communication link with the mobile device, upon detection of the presence of the user from the shock pattern.

In an embodiment, the proximity detector comprises a visual detector connected to the controller and configured to generate electrical signals indicative of detected motion. The controller is configured to detect gestures from the electrical signals and to control the radio communication module to establish the direct wireless communication link with the mobile device, upon detection of the presence of the user from the gestures.

In an embodiment, the proximity detector comprises a photo detector connected to the controller and configured to generate electrical signals indicative of detected shadowing of the photo detector. The controller is configured to control the radio communication module to establish the direct wireless communication link with the mobile device, in response to the electrical signal indicating shadowing of the photo detector.

In an embodiment, the proximity detector comprises a capacitive sensor connected to the controller and configured to detect the presence of the user in proximity to the electronic access control device. The controller is configured to control the radio communication module to establish the direct wireless communication link with the mobile device, upon detection of the presence of the user by the capacitive sensor.

In an embodiment, the proximity detector comprises a continuous-wave radar system connected to the controller. The continuous-wave radar system uses a radio frequency in a second radio frequency band different from the first radio frequency band and is configured to generate an electrical signal indicative of a detected presence of the user. The controller is configured to control the radio communication module to establish the direct wireless communication link with the mobile device, in response to the electrical signal indicating the detected presence of the user.

In an embodiment, the proximity detector comprises an electromechanical switch that is connected to the controller and configured to generate an electrical signal indicative of a switching action and thus presence by the user. The controller is configured to control the radio communication module to establish the direct wireless communication link with the mobile device, in response to the electrical signal indicating the switching action and thus the detected presence of the user.

In a further embodiment, the proximity detector comprises an RFID reader and is configured to detect the presence of the mobile device by emitting an electromagnetic field pulse, detecting a return signal during emission of the electromagnetic field pulse, and using the return signal to detect the presence of the mobile device. Thus, the proximity detector is configured to detect the presence of the mobile device based merely on changes in the electromagnetic field caused by the physical presence of the mobile device in the electromagnetic field – the mobile device does not need to be equipped with any corresponding communication features for that purpose.

In an embodiment, the radio communication module comprises a Bluetooth transceiver, and the controller is further configured to control the Bluetooth transceiver to establish the direct wireless communication link with the mobile device by performing a Bluetooth connection process. For example, the radio communication module comprises a Bluetooth Low Energy transceiver.

In another embodiment, the controller is further configured to control the Bluetooth transceiver to act in a Bluetooth central mode as master for establishing the direct wireless communication link with the mobile device acting in a Bluetooth peripheral mode as a slave, and, upon failure of a response, to control the Bluetooth transceiver to act in

the Bluetooth peripheral mode as slave for having the direct wireless communication link established by the mobile device acting in the Bluetooth central mode as the master.

In yet a further embodiment, the controller is further configured to control the radio communication module to transmit to the mobile device an executable access confirmation module. The executable access confirmation module is configured to control a processor of the mobile device to receive from a user of the mobile device a confirmation instruction and to transmit to the radio communication module of the access control device a confirmation message responsive to the confirmation instruction. The controller is further configured to receive the confirmation message from the mobile device and to generate the access control signal further using the confirmation message.

In an embodiment, the executable access confirmation module is further configured to control the processor of the mobile device to receive the confirmation instruction from the user of the mobile device through a finger print sensor of the mobile device and/or a graphical user interface of the mobile device.

In a further embodiment, the executable access confirmation module is further configured to control the processor of the mobile device to include the access key in the confirmation message, and the controller is further configured to obtain the access key from the confirmation message for generating the access control signal.

In another embodiment, the controller is further configured to control the radio communication module to transmit to the mobile device the executable access confirmation module, only if a received signal strength of the radio communication module meets and/or exceeds a defined threshold value, indicative of a maximum distance of the mobile device from the access control device of one meter, and to

generate the access control signal regardless of the received signal strength of the confirmation message.

In an embodiment, the controller is configured to control the radio communication module to establish the direct wireless communication link with the mobile device, only
5 upon detection of the mobile device by the proximity detector in the defined proximity of the electronic access control device, *and* upon verification that the received signal strength (of the mobile device as) indicated by the radio communication module meets a defined threshold value, indicative of a defined maximum distance of the mobile device from the access control device, e.g. a defined maximum distance of 0.5 or 1 meter. This
10 makes it possible to maintain security, in cases where the user uses another object to trigger the proximity detector, in that it is verified that the mobile device is indeed close to the access control device, i.e. within maximum distance from the access control device.

In an embodiment, the access control device further comprises an electronic lock, and the controller is connected to the electronic lock and further configured to supply the access
15 control signal to the electronic lock for controlling the electronic lock to perform an unlock function, e.g. to unlock an entrance, such as a door or a gate.

In another embodiment, the controller is further configured to define an access status reflective of the access control signal, and to control the radio communication module to transmit the access status to the mobile device.

20 In addition to the electronic access control device, the present invention also relates to an access control method. The access control method comprises providing an electronic access control device with a radio communication module configured to establish with a mobile device a direct wireless communication link for a wireless data exchange in a first

radio frequency band. The method further comprises detecting by a proximity detector of the electronic access control device a presence of a user of the mobile device in proximity of the electronic access control device not using a radio frequency in the first radio frequency band. The method further comprises controlling the radio communication module of the electronic access control device to establish with the mobile device a direct wireless communication link for a wireless data exchange in the first radio frequency band, upon detection of the user by the proximity detector in the proximity of the electronic access control device. Subsequently, the radio communication module of the electronic access control device receives an access key from the mobile device via the direct wireless communication link, and generates in the electronic access control device an access control signal using the access key received from the mobile device.

A further aspect of the present invention relates to an electronic access control device that comprises: a radio communication module configured to perform a wireless data exchange with a mobile device over a direct wireless communication link between the radio communication module and the mobile device; a controller connected to the wireless radio communication module and configured to generate an access control signal using an access key received by the radio communication module via the direct wireless communication link from the mobile device; and a proximity detector configured to detect a presence of a user in defined proximity to the electronic access control device using a capacitive sensor, whereby the controller is connected to the proximity detector or its capacitive sensor, respectively, and is further configured to control the radio communication module to establish the direct wireless communication link with the mobile device, upon detection of the user by the proximity detector in the defined proximity of the electronic access control device, and upon verification that a received signal strength indicated by the radio communication module meets a defined threshold

value, indicative of a defined maximum distance of the mobile device from the access control device.

For example, the controller is configured to control the radio communication module to establish the direct wireless communication link with the mobile device, only if the user is
5 detected in a defined proximity of up to 3 or 5 centimeters from the electronic access control device and if the received signal strength of the mobile device, as indicated by the radio communication module, is at or above a defined threshold value that indicates a maximum distance of the mobile device of 0.5 or 1 meter from the access control device. For example, the capacitive sensor is connected to or arranged close to a door handle,
10 and the proximity of the user is detected when the user holds his hand close to the door handle.

Brief Description of the Drawings

The present invention will be explained in more detail, by way of example, with reference to the drawings in which:

15 Figure 1: shows a block diagram illustrating schematically an electronic access control device with a radio communication module and a radio based proximity detector;

Figure 2: shows a block diagram illustrating schematically an access control system with an electronic access control device, an access rights server, and mobile
20 device;

Figure 3: shows a flow diagram illustrating an exemplary sequence of steps for electronic access control;

Figure 4: shows a flow diagram illustrating an exemplary sequence of steps for establishing a direct wireless communication link between an electronic access control device and a mobile device;

5 Figure 5: shows a flow diagram illustrating an exemplary sequence of steps for transmitting an access key from a mobile device to an electronic access control device;

Figure 6: shows a block diagram illustrating schematically a proximity detector with one or more detector modules.

Detailed Description of the Preferred Embodiments

10 In Figures 1-5, reference numeral 1 refers to an electronic access control device. The electronic access control device 1 comprises one or more electronic circuits and modules powered by one or more batteries or an external power supply connected to the device.

As is illustrated schematically in the embodiment of Figure 1, the electronic access control device 1 comprises an electronic/electric lock 14 for locking and unlocking an entrance, such as a door, a gate or the like, to an access controlled area, such as a building, a car, or a room. Responsive to an access control signal, the electronic lock 14 drives one or more bars or bolts to lock or unlock an entrance to the access controlled area. The electronic lock 14 is implemented together with the remaining components of the electronic access control device 1 in a common housing or in separate housings. One skilled in the art will understand that depending on the application, e.g. to control access to objects in a vending machine, the electronic access control device 1 or the electronic lock 14, respectively, are configured accordingly to block or grant access, e.g. to unlock or deliver objects in or from a vending machine.

15
20

As is shown in Figure 1, the electronic access control device 1 further comprises a radio communication module 11, a controller 12, and a proximity detector 13. The controller is electrically connected to the communication module 11 and the proximity detector 13.

The radio communication module 11 is configured to perform a wireless data exchange
5 with a mobile device 2 over a direct wireless communication link 3 between the radio communication module 11 and the mobile device 2. The term "direct" is to indicate that the wireless communication link 3 includes no intermediate components, such as routers, repeaters, gateways, wire networks, base stations, etc., between the radio communication module 11 and the mobile device 2. The radio communication module
10 11 is configured to perform the wireless data exchange over a short distance S of several meters, particularly over a distance of up to five, ten, or twenty meters. In an embodiment, the radio communication module 11 comprises a Bluetooth transceiver, specifically a Low Energy Bluetooth transceiver. The radio communication module 11 is configured to operate in a frequency band from 2.4 to 2.485 GHz, using (Ultra High
15 Frequency UHF) microwaves. In an alternative embodiment, the radio communication module 11 comprises a WLAN communication module based on IEEE 802.11 standards, e.g. operating in a frequency band from 2.4 GHz to 5 GHz.

The controller 12 comprises a programmable microprocessor with computer program code, a field programmable gate array, an application specific integrated circuit, and/or
20 another electronic circuit configured to execute various functions, as described later in more detail.

In the following paragraphs described with reference to Figure 6 are various embodiments of the proximity detector 13. As illustrated schematically in Figure 6, the proximity detector 13 comprises one or more detector modules for detecting the

presence of a user in proximity to the electronic access control device 1. Specifically, the proximity detector 13 comprises a non-radio-based proximity detector 13NR and an optional radio-based proximity detector 13R. The non-radio based proximity detector 13NR is configured to detect the presence of the user without using radio waves. The non-radio-based proximity detector 13NR includes one or more non-radio-based detector modules, including a capacitive sensor 130, a photo detector 132, a visual detector 133, a shock detector 134, and/or an electromechanical switch 136. The radio-based proximity detector 13R includes a continuous wave radar system 135 for detecting the presence of the user using a radio frequency in a different radio frequency band than the radio communication module 11.

The shock detector 134 is connected to the controller 12 and configured to generate an electrical signal indicative of detected mechanical shock. Depending on the embodiment, the shock detector 134 comprises an accelerometer and/or a gyroscopic sensor. The shock detector 134 is arranged in or on a door and configured to detect a user knocking or kicking at the door or activating a door handle. The controller 12 is configured to detect from the electrical signal received from the shock sensor 134 (e.g. via an analog/digital converter) a shock pattern, e.g. a series of two or more knocks, to distinguish a user's intentional knocking from accidental hits at the door, or a door handle activation. The controller 12 detects the presence of a user when the shock pattern derived from the shock detector's 134 signal matches or at least correlates (within a defined error threshold) with a stored shock pattern.

The visual detector 133 is connected to the controller 12 and configured to generate electrical signals indicative of detected motion. Depending on the embodiment, the visual detector 133 comprises a CCD-sensor (charge coupled device), specifically a CCD-array sensor for detecting motions, e.g. hand movements, within an area in proximity to the

access control device 1, e.g. within up to half a meter of the access control device 1 or the visual detector 133, respectively. The controller 12 is configured to detect from the electrical signals received from the visual detector 133 (e.g. via an analog/digital converter) gestures, e.g. waving or swiping hand movements, to distinguish a user's intentional gestures from accidental motions or movements in front of the door. The controller 12 detects the presence of a user when the gesture derived from the visual detector's 133 signal matches or at least correlates (within a defined error threshold) with a stored gesture.

The photo detector 132 is connected to the controller 12 and configured to generate an electrical signal indicative of detected shadowing of the photo detector. Depending on the embodiment, the photo detector 132 comprises a light sensor, specifically a photo resistor or a phototransistor, for detecting when photo detector 132 is being shadowed, e.g. from a light source, e.g. by a user placing his hand in front of the photo detector 132. The controller 12 is configured to detect from the electrical signal received from the photo detector 132 (e.g. via an analog/digital converter) the presence of a user when the photo detector 132 is shadowed, e.g. for at least a minimum duration of time to distinguish a user's intentional shadowing from accidental shadowing by a passing person or object in front of the door.

The capacitive sensor 130 is connected to the controller 12 and configured to detect the presence of a user in a defined proximity P to the electronic access control device 1, e.g. in a defined proximity P of 0-5 centimeters (e.g. 2-3 centimeters or 2-5 centimeters). Specifically, the capacitive sensor 130 is configured to detect the presence of a user's hand in the defined proximity P to the electronic access control device 1. For example, the capacitive sensor 130 is a Capsense MBR3 sensor from Cypress (Capsense is registered trademark of Cypress Semiconductor Corp.), e.g. a Capsense MBR3 sensor

CY8CMBR3108. For example, the capacitive sensor 130 is electrically connected to a metal door handle or to an antenna arranged close to the door handle or a marked area of the entrance to the access controlled area. In this embodiment, the controller 12 is connected to the proximity detector 13 or the capacitive sensor 130, respectively, and is further configured to control the radio communication module 11 to establish the direct wireless communication link 3 with the mobile device 2, upon detection of the user by the proximity detector 13 in the defined proximity P of the electronic access control device 1.

The continuous wave radar system 135 is connected to the controller 12 and configured to generate an electrical signal indicative of a detected presence of the user. The continuous wave radar system 135 uses a radio frequency in a different radio frequency band than the radio communication module 11. In an alternative configuration, the continuous wave radar system 135 uses the radio communication module 11 to perform the continuous wave radar detection. Specifically, in this alternative embodiment, the radio communication module 11 is used as transmitter for transmitting stable frequency continuous-wave radio energy and as a receiver for receiving reflections from reflecting objects.

The electromechanical switch 136 is connected to the controller 12 and configured to generate an electrical signal indicative of a switching action and thus presence by the user.

The radio based proximity detector 13 is configured to detect the presence of a mobile device 2 in a defined proximity P of the electronic access control device 1, specifically, in close proximity P within a distance range of up to five, ten, or fifteen centimeters, e.g. adjustable by setting a sensitivity parameter in the access control device 1. The proximity

detector 13 configured to detect the presence of a mobile device 2 by emitting an electromagnetic field pulse 10, by detecting a return signal during emission of the electromagnetic field pulse 10, and using the return signal to detect the presence of the mobile device 2. Essentially, the proximity detector 13 is configured to detect the presence of a mobile device 2 by detecting a change in the electromagnetic field 10 emitted by the proximity detector 13 as caused by the presence of the mobile device 2. Specifically, the proximity detector 13 measures the return signal on the antenna 131 while it emits a defined electromagnetic field pulse 10, and determines in the return signal an attenuation, amplification, and/or shift in frequency as disclosed in patents EP 1 723 575 or EP 2 437 403 in the name of the applicant. In an embodiment, the proximity detector 13 comprises an RFID (Radio Frequency Identifier), e.g. an RFID reader in according with ISO 18092, ISO 21481, ISO 15693, and/or ISO 14443. The proximity detector 13 is configured to operate at a carrier frequency of an RFID system, e.g. 6.78MHz, 13.56MHz, or 27.12MHz (or another multiple of 13.56MHz), using (High Frequency HF) radio waves.

Thus, the radio based proximity detector 13 uses a different, i.e. a lower, frequency band than the radio communication module 11. As is clearly shown in Figure 1, the radio based proximity detector 13 and the radio communication module 11 are two distinct (radio based communication) modules of the access control device 1, each having its own transceiver circuit and its own antenna 111, 131. The radio based proximity detector 13 and the radio communication module 11 are two different and separate communication units, e.g. each implemented in a different integrated circuit (chip), and provide the access control device 2 with two different and separate communication channels.

The mobile device 2 is implemented as a mobile radio telephone (i.e. a cellular phone), a tablet or notebook computer, a computerized watch, or another mobile communication device. As illustrated schematically in Figure 1, the mobile device 2 comprises a radio communication module 21 and a programmable processor 22 connected thereto. The radio communication module 21 is configured to exchange data with the radio communication module 11 of the access control device 1 via the direct wireless communication link 3.

As shown in Figure 2, the access control system 100 comprises one or more electronic access control devices 1 and an access rights server 5 connected to the electronic access control devices 1 via a communication network 4. Depending on the implementation, the communication network 4 includes a LAN (Local Area Network), another wired network, a WLAN (Wireless LAN), and/or another mobile radio network, such as a GSM (Global System for Mobile communication) or a UMTS network (Universal Mobile Telephone System), and may include the Internet.

The access rights server 5 comprises one or more operable computers with one or more processors configured to transmit to the mobile devices 2 access keys and to transmit to the electronic access control devices 1 access keys and/or decryption keys. In an embodiment, the access rights server 5 or its computers/processors, respectively, are further configured to transmit to the mobile devices 2 and/or the electronic access control devices 1 an executable access confirmation module 23. Alternatively, the executable access confirmation module 23 is transmitted to the mobile devices 2 by an application server 7 via a telecommunications network 6 that includes a mobile radio network as mentioned above.

The executable access confirmation module 23 comprises computer program code configured to control a processor of the respective mobile device 2 such that it executes various functions as described later in more detail. In an embodiment, the executable access confirmation module 23 is implemented as a so called applet and comprises
5 interpretable computer program code for a virtual machine, e.g. Java code configured to run on a Java virtual machine (Java is a registered trademark by Sun Microsystems, Inc.).

In the following paragraphs, described with reference to Figures 3-5 are possible sequences of steps for electronic access control, performed by the functional modules of the access control device 1, the mobile device 2, and the access rights server 5.

10 In preparatory step S0, the access right server 5 transfers to the mobile device 2 an access key for accessing an area with controlled access, controlled by the access control device 1. The access key is transferred securely, e.g. via Transport Layer Security (TLS), Secure Sockets Layer (SSL), or other cryptographic protocols for secure data communication. In an embodiment the access key is transferred to the mobile device 2
15 via an NFC interface, a Bluetooth interface, or a Bluetooth beacon. For example, for transmitting the access key to the mobile device 2, an NFC terminal is installed on a counter or desk of the hotel reception, or the Bluetooth terminal (interface) or Bluetooth beacon is installed in the reception area of the hotel, respectively. Depending on the embodiment and configuration, the access right server 5 further transfers the access key
20 or cryptographic elements for verifying the access key to the respective access control device 1. Alternatively, the access key or the cryptographic elements, respectively, are stored in the access control device 1 prior to being transferred to the mobile device 2. For example, the access key is an encrypted secret (e.g. a secret access authorization code) and the access control device 1 uses a secret decryption key to verify the secret.

In an embodiment, the access right server 5 further transfers to the mobile device 2 the executable access confirmation module 23 mentioned above. In a further embodiment, the access key is transferred to the mobile device as part of the executable access confirmation module 23.

- 5 For example, in case of a hotel application, the access key and, if applicable, the executable access confirmation module 23 are transmitted to the mobile devices 2 during the checking in procedure at the reception.

In step S1, the access control device 1 or its proximity detector 13, respectively, detects the presence of the mobile device 2 and/or its user in defined (close) proximity P to or
10 close range C of distance from the access control device 1. For that purpose, the user of the mobile device 2 physically moves and places the mobile device 2 into the defined (close) proximity range P of the access control device 2 or the antenna 131 of its proximity detector 13, respectively. Alternatively, to indicate its presence to the access control device 1, the user knocks at the door or another designated area to activate the
15 shock detector 134, waves or makes another defined gesture for detection by the visual detector 133, shadows the photo detector 132, touches the door handle or another designated area to activate the capacitive sensor 130, approaches the door to activate the continuous wave radar system 135, and/or activates the electromechanical switch 136 on or next to the door.

20 In step S2, upon detection of the mobile device 2 and/or its user in defined (close) proximity P to or close range C of distance from the access control device 1 or its proximity detector 13, respectively, the controller 12 of the access control device 1 controls the radio communication module 11 to establish a direct wireless communication link 3 with the mobile device 2.

In the embodiment illustrated in Figure 4, in step S21, the access control device 1 or its controller 12, respectively, control the radio communication module 11 to act as a master for establishing the direct wireless communication link 3. Specifically, the controller 12 sets the Bluetooth transceiver of the radio communication module 11 in
5 Bluetooth central mode.

In step S22, the radio communication module 11 performs a connection process; specifically, the Bluetooth transceiver initiates a Bluetooth connection process and scans for Bluetooth slaves. If successful, the access control device 1 and the mobile device 2 or their radio communication modules 11, 21, respectively, establish the direct wireless
10 communication link 3 as a Bluetooth paired connection. As one skilled in the art will understand, with Bluetooth (BT), the establishment of a connection uses a preceding pairing process, whereas Bluetooth Low Energy (BTLE) does not include a pairing process.

Otherwise, the controller 12 proceeds in step S23 by controlling the radio
15 communication module 11 to act as a slave for letting the mobile device 2 establish the direct wireless communication link 3. Specifically, the controller 12 sets the Bluetooth transceiver of the radio communication module 11 in Bluetooth peripheral mode.

In step S24, the mobile device 2 or its radio communication module 21, respectively, performs the connection process; specifically, the Bluetooth transceiver of the mobile
20 device 2 initiates a Bluetooth connection process and scans for Bluetooth slaves. If successful, the mobile device 2 and the access control device 1 or their radio communication modules 11, 21, respectively, establish the direct wireless communication link 3 as a Bluetooth paired connection and proceed to step S3.

Otherwise, in step S25, the access control device 2 displays an error message, e.g. indicating to the user that, before repeating the process, the communication module 21 of the mobile device 2 should be activated. In a further embodiment, in cases where the mobile device 2 can be associated with the respective access control device 1, the access control device 1 requests the access right server 5 to send to the user of the mobile device 2 a similar error message.

In an embodiment, for increased versatility, upon detection of the mobile device 2 and/or its user in defined (close) proximity P to or close range C of distance from the access control device 1 or its proximity detector 13, respectively, the controller 12 of the access control device 1 is configured to select, from different types of radio communication module implemented in the access control device 1, a preferred radio communication module for establishing the direct wireless communication link 3 with the mobile device 2. Specifically, the controller 12 is configured to select the Bluetooth transceiver or the WLAN communication module as described above, or an NFC interface, e.g. implemented in the RFID reader of the proximity detector 13 described above. Depending on the embodiment or configuration, the selection of the preferred radio communication module is performed by the controller 12 using a preference table, stored in the access control device 1, or according to programmable selection rules, defining the priority or order in which the access control device 1 selects the radio communication module for establishing the direct wireless communication link 3 with the mobile device 2.

In step S3, once the direct wireless communication link 3 is set up between the mobile device 2 and the access control device 1 or their radio communication modules 11, 21, respectively, the mobile device 2 or its radio communication module 21, respectively, transfers the access key via the direct wireless communication link 3 to the access control

device 1. Specifically, the access confirmation module 23 is executed and controls the processor 22 of the mobile device 2 to transfer the access key to the access control device 1. Execution of the access confirmation module 23 is triggered once the direct wireless communication link 3 is set up between the mobile device 2 and the access control device 1 or their radio communication modules 11, 21, respectively. In an embodiment, execution of the access confirmation module 23 is triggered by the access control device 1 transmitting an execution request via the direct wireless communication link 3 to the mobile device 2.

As illustrated in Figure 5, in step S33, the mobile device 2 or the access confirmation module 23 requests and receives from the user of the mobile device a confirmation instruction, prior to transferring the access key to the access control device 1. Depending on the embodiment, the access confirmation module 23 generates and displays on a display of the mobile device 2 a graphical user interface, e.g. a "cancel" and an "ok" button, for the user to confirm the intended access to the area controlled by the access control device 1. In an embodiment, the user is required to enter authorization information, such as an access code or password. Alternatively or in addition, the access confirmation module 23 uses a fingerprint sensor of the mobile device 2 to receive an affirmative confirmation from the user.

In step S34, if the user has entered the required confirmation instruction, e.g. by successfully pressing the "ok" button and/or the fingerprint sensor, the access confirmation module 23 generates a confirmation message which includes the access key. The confirmation message, and thus the access key, is transferred from the mobile device 2 via the direct wireless communication link 3 to the access control device 1.

In step S35, access control device 1 or its controller 12, respectively, receives the confirmation message from the radio communication module 11 via the direct wireless communication link 3. The controller 12 extracts the access key from the confirmation message received from the mobile device 1.

5 Optional steps S30, S31, S32 are applicable in an embodiment/scenario where the access confirmation module 23 is not preloaded and preinstalled in the mobile device 2, but loaded and installed dynamically when the mobile device 2 is detected within defined (close) proximity of the access control device 1. In the embodiment illustrated in Figure 5, the controller 12 checks whether the Received Signal Strength Indicator (RSSI) indicates a
10 signal strength of the mobile device 2 or its radio communication module 21, respectively, that corresponds to a defined close range C of distance from the access control device 1, e.g. a maximum distance of mobile device 2 from the access control device 1 of half a meter, one meter, or two meters, e.g. adjustable by setting a distance parameter in the access control device 1. If the RSSI values is above the set signal strength
15 threshold and the mobile device 2 is thus located within the defined close range C of distance from the access control device 1, in step S31, the controller 12 uses the radio communication module 11 to transfer the access confirmation module 23 via the direct wireless communication link3 to the mobile device 2.

In step S32, the processor 22 of the mobile device 2 receives and executes the access
20 confirmation module 23. The access confirmation module 23 requests from the user of the mobile device 2 a confirmation instruction, e.g. by displaying a respective request on a display of the mobile device 2 asking the user to press a confirmation button and/or place a finger on a finger print sensor, depending on the configuration and/or embodiment.

In step S33, the access confirmation module 23 receives from the user of the mobile device 2 the confirmation instruction, e.g. via a graphical user interface and/or a finger print sensor. If the confirmation is affirmative, e.g. the user pressed the "ok" button or the finger print sensor read and verified the user's finger print as legitimate (authorized), the access confirmation module 23 generates an affirmative confirmation message which includes the access key, e.g. in encrypted form as previously received from the access rights server 5.

In step S34, the processor 22 of the mobile device 2 uses the radio communication module 21 to transfer the confirmation message, and thus the access key, via the direct wireless communication link 3 to the access control device 1.

In step S35, the controller 12 extracts the access key from the received confirmation message.

As illustrated in Figure 3, in step S4, the controller 12 checks and verifies the access key received from the mobile device 2. Depending on the embodiment, the controller 12 decrypts the received access key and compares the decrypted access key to a verification key stored in the access control device 1. One skilled in the art will understand that there are various cryptographic functions and algorithms for verifying an access key and that the different levels and types of access rights may be associated with a particular access key, e.g. permitted access dates and/or time periods. In any case, steps S0-S4 provide an end-to-end encryption of the access key or secret access authorization between the access rights server 5 and the access control device 1.

In optional step S41, if the access key cannot be properly verified, the controller 12 uses the radio communication module 11 to transfer an error message via the direct wireless communication link 3 to the mobile device 2.

In optional step S42, the processor 22 of the mobile device 2 receives the error message and renders it on the mobile device 2, e.g. by displaying it on a display of the mobile device 2 and/or generating an acoustic alarm on the mobile device 2.

In step S5, responsive to a positive verification of the received access key, the controller 12 generates an access control signal, e.g. in form of an electrical signal or a data value. Depending on the embodiment and/or configuration, the access control signal represents an unlock command which is different and distinguishable from a lock command.

In step S50, the controller 12 applies the access control signal to the electronic lock 14, e.g. via an electrical signal line or a data register connected or accessible to the electronic lock 14.

In step S51, responsive to the access control signal from the controller 12, the electronic lock 14 performs an unlocking function, e.g. it drives a bar or bolt to mechanically unlock a door, gate, or the like to clear access through an entrance to an access controlled area, e.g. a building or a room, such as a hotel room.

In optional step S52, the electronic lock 14 returns to the controller 12 an unlock confirmation or unlocked status signal, e.g. in form of an electrical signal or a data value.

In step S6, the controller 12 determines and defines an access status that corresponds to and reflects the access control signal. For example, the access status indicates an "open"

state, corresponding to an unlock command, or a "closed" state, corresponding to a lock command. In the embodiment that includes optional step S52, the controller 12 determines and defines the access status using the unlock confirmation or unlocked status signal from the electronic lock 14.

- 5 In optional step S61, the controller 12 uses the radio communication module 11 to transfer an access status message, which includes the access status, via the direct wireless communication link3 to the mobile device 2.

In optional step S62, the processor 22 of the mobile device 2 receives the access status message and displays the access status on a display of the mobile device 2.

- 10 The controller 12 is further configured to check and verify, as an additional second condition for establishing the direct wireless communication link 3, that the received signal strength of the mobile device 2, as indicated by the radio communication module 11, meets a defined threshold value which indicates that the mobile device 2 is within a defined maximum distance from the access control device 1. For example, the controller
- 15 12 is configured to control the radio communication module 11 to establish the direct wireless communication link 3 with the mobile device 2, only if the user is detected in a defined proximity of 0-5 centimeters from the electronic access control device 1 and if the received signal strength of the mobile device 2, as indicated by the radio communication module 11, is at or above a defined threshold value that indicates a
- 20 maximum distance of the mobile device 2 of 0.5 or 1 meter from the access control device 1.

In an embodiment, two or more access control devices 1 share one radio communication module 11. For example, in a hotel scenario, the access control devices 1 of two

neighboring hotel rooms are connected to a common radio communication module 11 which is installed externally to (door-side mounted) housings of the two access control devices 1, e.g. in the ceiling with approximately equal or at least similar distance to the two access control devices 1 (in a ceiling-side housing). The external radio communication module 11 is connected through a wired connection to the access control devices 1 or their controllers 12, respectively. As described above with reference to step 5 S2, upon detection of the mobile device 2 by the proximity detector 13 in defined proximity P of one of the electronic access control devices 1, the respective controller 12 of that electronic access control device 1 controls the external radio communication module 11 to establish a direct wireless communication link 3 with the mobile device 2. For that purpose, the controller 12 transmits to the external radio communication module 11 a detection signal. Alternatively, the external radio communication module 11 establishes a direct wireless communication link 3 with the mobile device 2, regardless of a detection signal from the access control device 1, while the detection signal enables the external radio communication module 11 to identify the particular access control device 1 that effectively detected the mobile device 1 in defined proximity P. Subsequently, operation continues in step S3 as described above with reference to Figures 3 and 5. In an alternative scenario and configuration, the external radio communication module 11 is connected through the wired connection to one access control device 1 that has two or more antennas 131, whereby each of the antennas 131 is associated with a different door or its electronic lock 14, respectively. In this alternative configuration, the controller 12 determines the electronic lock 14 to be opened based on the antenna 131 through which the mobile device 2 was detected by the proximity detector 13 in defined proximity P of the electronic access control device 1 or the particular antenna 131, respectively. The communication between the external radio communication module 11 and the mobile device takes place as described above.

It should be noted that, in the description, the computer program code has been associated with specific functional modules and the sequence of the steps has been presented in a specific order, one skilled in the art will understand, however, that the computer program code may be structured differently and that the order of at least some
5 of the steps could be altered, without deviating from the scope of the invention.

Claims

1. An electronic access control device comprising:

a radio communication module configured to perform a wireless data exchange in a first radio frequency band with a mobile device over a direct wireless communication link between the radio communication module and the mobile device;

a controller connected to the wireless radio communication module and configured to generate an access control signal using an access key received by the radio communication module via the direct wireless communication link from the mobile device; and

a proximity detector configured to detect a presence of a user of the mobile device in proximity (P) of the electronic access control device not using a radio frequency in the first radio frequency band; and

the controller is connected to the proximity detector and further configured to control the radio communication module to establish the direct wireless communication link with the mobile device upon detection of the presence of the user by the proximity detector, for enabling the mobile device to transmit the access key to the radio communication module,

characterized in that the controller is further configured to control the radio communication module to transmit to the mobile device an executable access confirmation module, the executable access confirmation module comprising program code configured to control a processor of the mobile device to receive from a user of the mobile device a confirmation instruction and to transmit to the radio communication module of the access control device a confirmation message responsive to the confirmation instruction; to receive the confirmation message from

the mobile device; and to generate the access control signal further using the confirmation message.

2. The access control device of claim 1, wherein the proximity detector is a non-radio based proximity detector configured to detect the presence of the user without using radio waves.
3. The access control device of any one of claims 1 or 2, wherein the proximity detector comprises a shock detector connected to the controller and configured to generate an electrical signal indicative of detected mechanical shock, and the controller is configured to detect a shock pattern from the electrical signal, and to control the radio communication module to establish the direct wireless communication link with the mobile device, upon detection of the presence of the user from the shock pattern.
4. The access control device of any one of claims 1 to 3, wherein the proximity detector comprises a visual detector connected to the controller and configured to generate electrical signals indicative of detected motion, and the controller is configured to detect gestures from the electrical signals, and to control the radio communication module to establish the direct wireless communication link with the mobile device, upon detection of the presence of the user from the gestures.
5. The access control device of any one of claims 1 to 4, wherein the proximity detector comprises a photo detector connected to the controller and configured to generate an electrical signal indicative of detected shadowing of the photo detector, and the controller is configured to control the radio communication module to establish the direct wireless communication link with the mobile device, in response to the electrical signal indicating shadowing of the photo detector.
6. The access control device of any one of claims 1 to 5, wherein the proximity detector comprises a capacitive sensor connected to the controller and configured

to detect the presence of the user in proximity to the electronic access control device, and the controller is configured to control the radio communication module to establish the direct wireless communication link with the mobile device, upon detection of the presence of the user by the capacitive sensor.

7. The access control device of claim 1, wherein the proximity detector comprises a continuous-wave radar system connected to the controller, the continuous-wave radar system uses a radio frequency in a second radio frequency band different from the first radio frequency band and is configured to generate an electrical signal indicative of a detected presence of the user, and the controller is configured to control the radio communication module to establish the direct wireless communication link with the mobile device, in response to the electrical signal indicating the detected presence of the user.
8. The access control device of any one of claims 1 to 7, wherein the radio communication module comprises a Bluetooth transceiver, and the controller is further configured to control the Bluetooth transceiver to establish the direct wireless communication link with the mobile device by performing a Bluetooth connection process.
9. The access control device of claim 8, wherein the controller is further configured to control the Bluetooth transceiver to act in a Bluetooth central mode as master for establishing the direct wireless communication link with the mobile device acting in a Bluetooth peripheral mode as a slave, and, upon failure of a response, to control the Bluetooth transceiver to act in the Bluetooth peripheral mode as slave for having the direct wireless communication link established by the mobile device acting in the Bluetooth central mode as the master.
10. The access control device of any one of claims 8 or 9, wherein the radio communication module comprises a Bluetooth Low Energy transceiver.

11. The access control device of claim 1, wherein the executable access confirmation module is further configured to control the processor of the mobile device to include the access key in the confirmation message, and the controller is further configured to obtain the access key from the confirmation message for generating the access control signal.
12. The access control device of any one of claims 1 or 11, wherein the controller is further configured to control the radio communication module to transmit to the mobile device the executable access confirmation module, only if a received signal strength of the radio communication module meets a defined threshold value, indicative of a maximum distance of the mobile device from the access control device of one meter, and to generate the access control signal regardless of the received signal strength of the confirmation message.
13. The access control device of any one of claims 1 to 12, wherein the access control device further comprises an electronic lock, and the controller is connected to the electronic lock and further configured to supply the access control signal to the electronic lock for controlling the electronic lock to perform an unlock function.
14. An access control method, the method comprising:

providing an electronic access control device which comprises a radio communication module configured to establish (S2) with a mobile device a direct wireless communication link for a wireless data exchange in a first radio frequency band;

detecting by a proximity detector of the electronic access control device a presence of a user of the mobile device in proximity of the electronic access control device not using a radio frequency in the first radio frequency band;

controlling the radio communication module of the electronic access control device to establish with the mobile device a direct wireless communication link for a wireless data exchange in the first radio frequency band, upon detection of the user by the proximity detector in the proximity of the electronic access control device;

receiving by the radio communication module of the electronic access control device an access key from the mobile device via the direct wireless communication link; and

generating in the electronic access control device an access control signal using the access key received from the mobile device, wherein the method further comprises

transmitting an executable access confirmation module from the access control device via the direct wireless communication link to the mobile device, the executable access confirmation module comprising program code configured to control a processor of the mobile device to receive from a user of the mobile device a confirmation instruction and to transmit to the access control device a confirmation message responsive to the confirmation instruction;

receiving by the radio communication module of the electronic access control device the confirmation message from the mobile device; and

generating in the electronic access control device the access control signal further using the confirmation message.

15. The method of claim 14, wherein the executable access confirmation module is transmitted from the access control device to the mobile device, only if a received signal strength of the radio communication module meets a defined threshold value, indicative of a maximum distance of the mobile device from the access control device of one of: half a meter, one meter, and two meters.

1/4

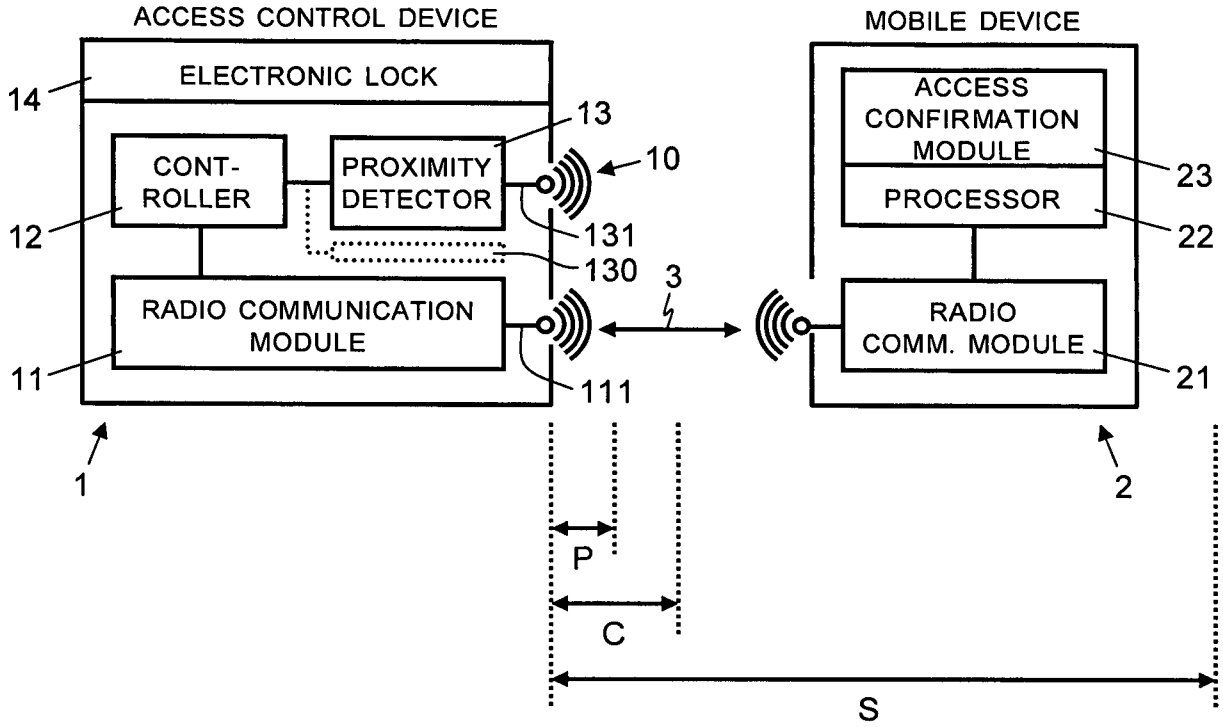

Fig. 1

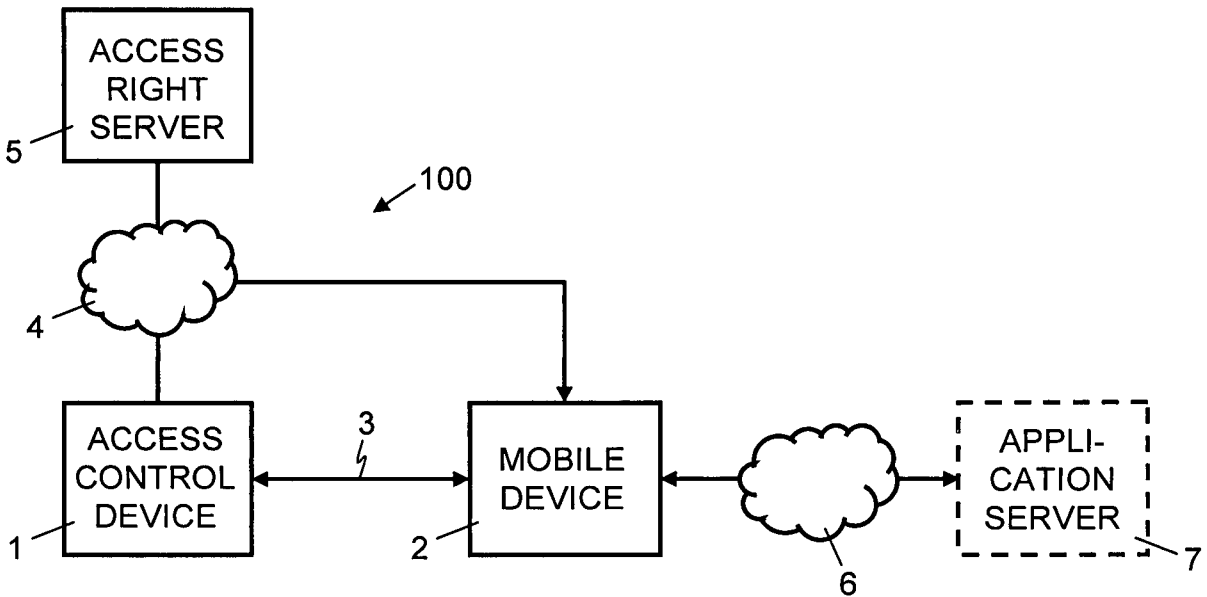

Fig. 2

2/4

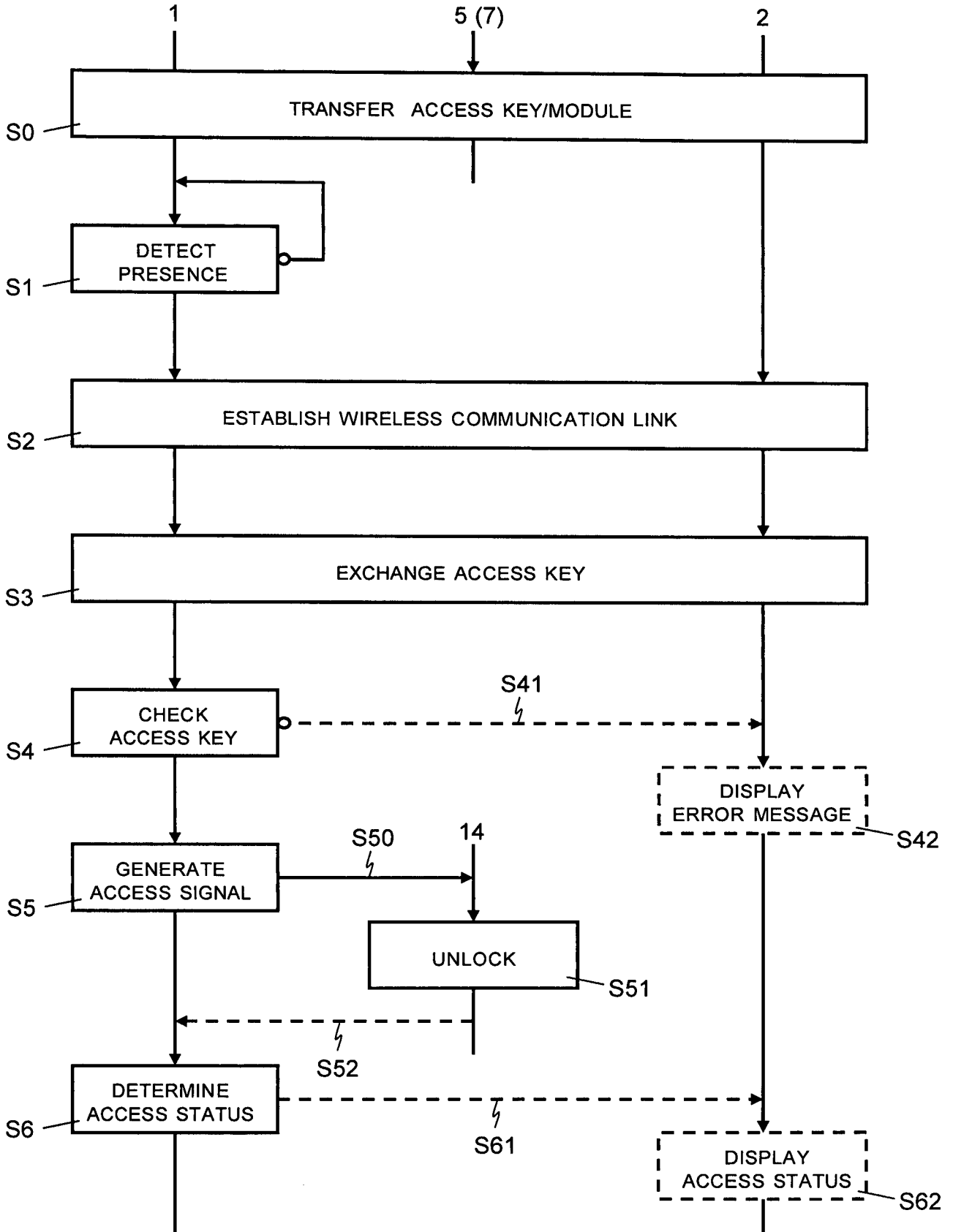

Fig. 3

3/4

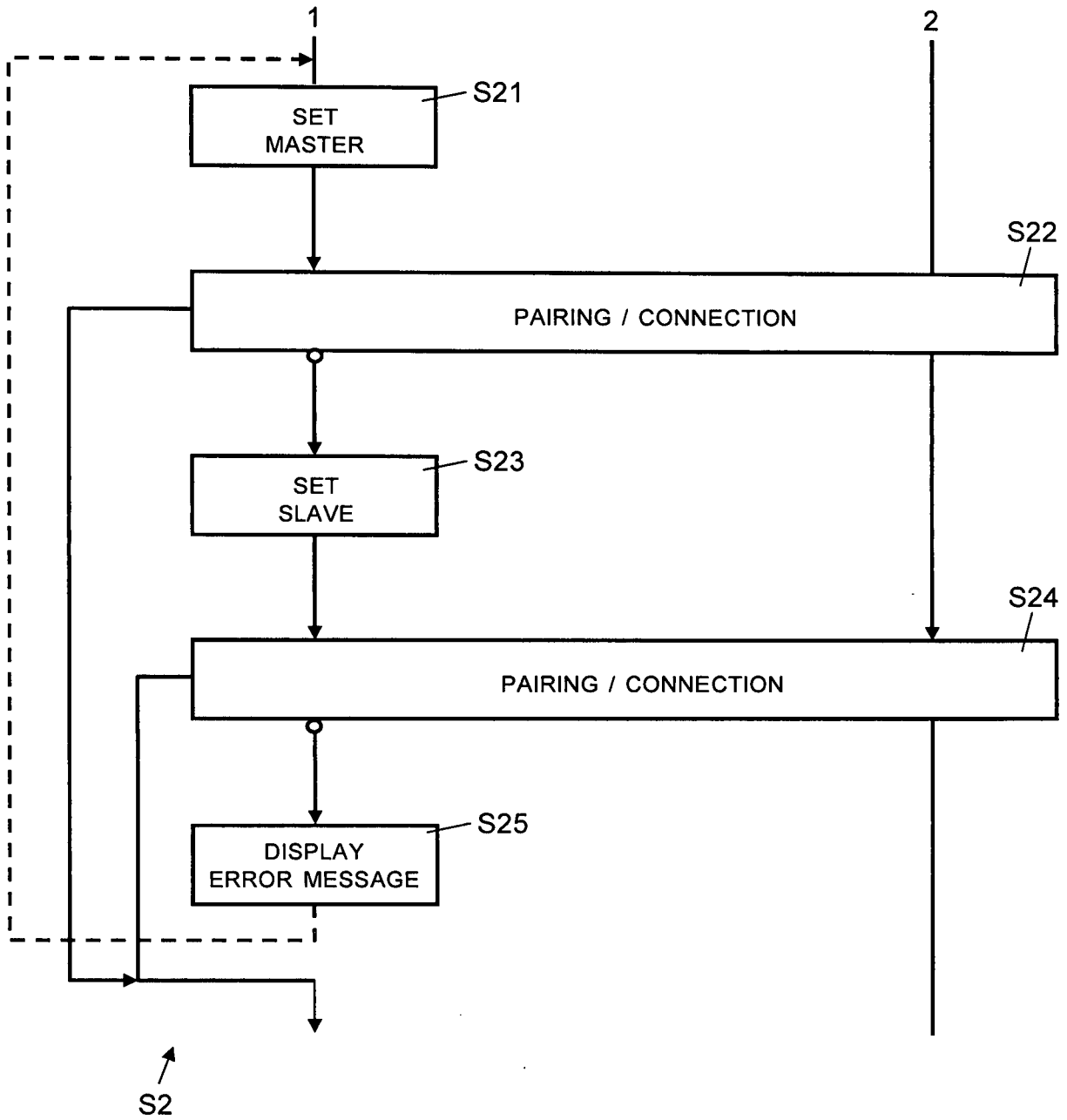

Fig. 4

4/4

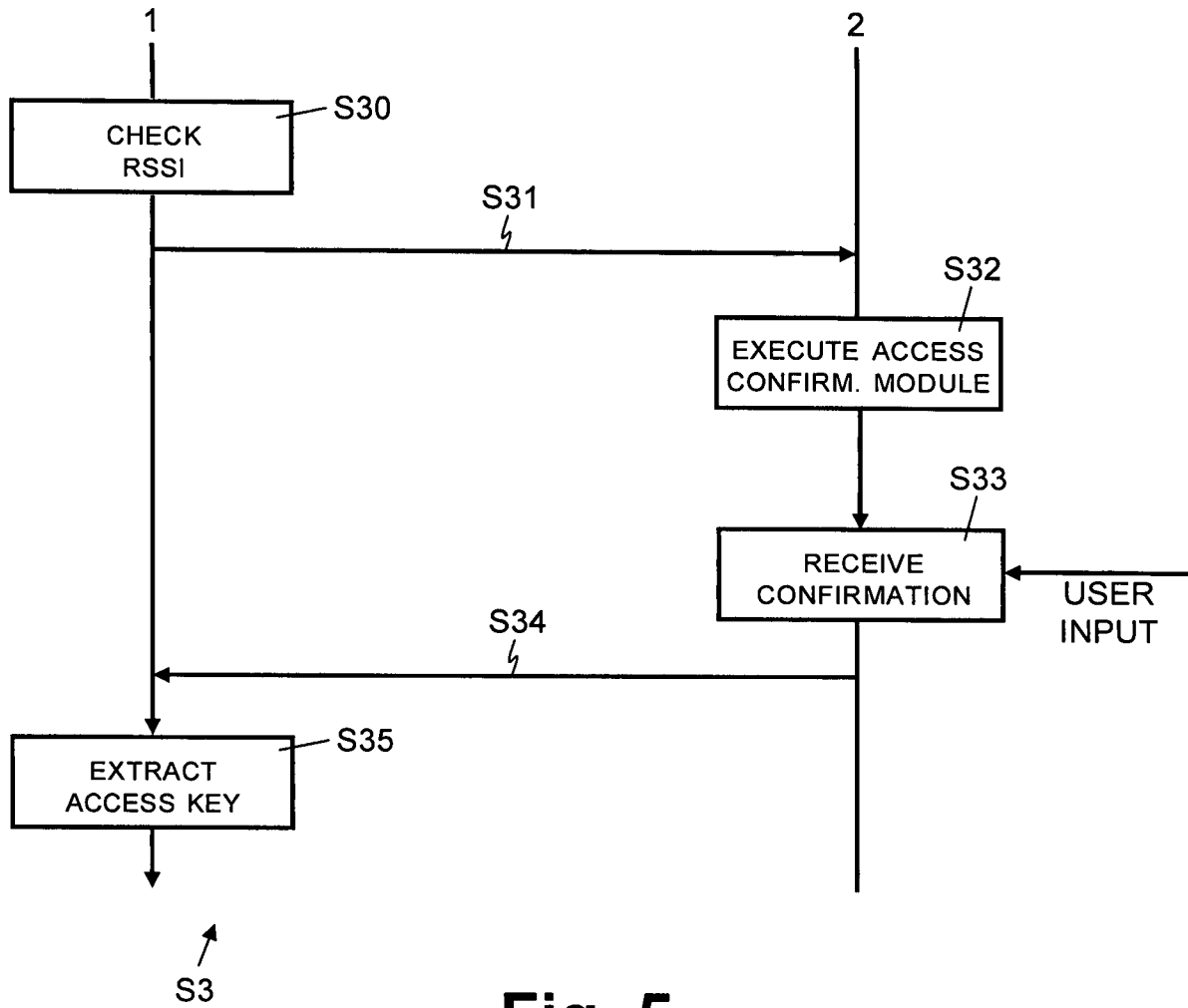

Fig. 5

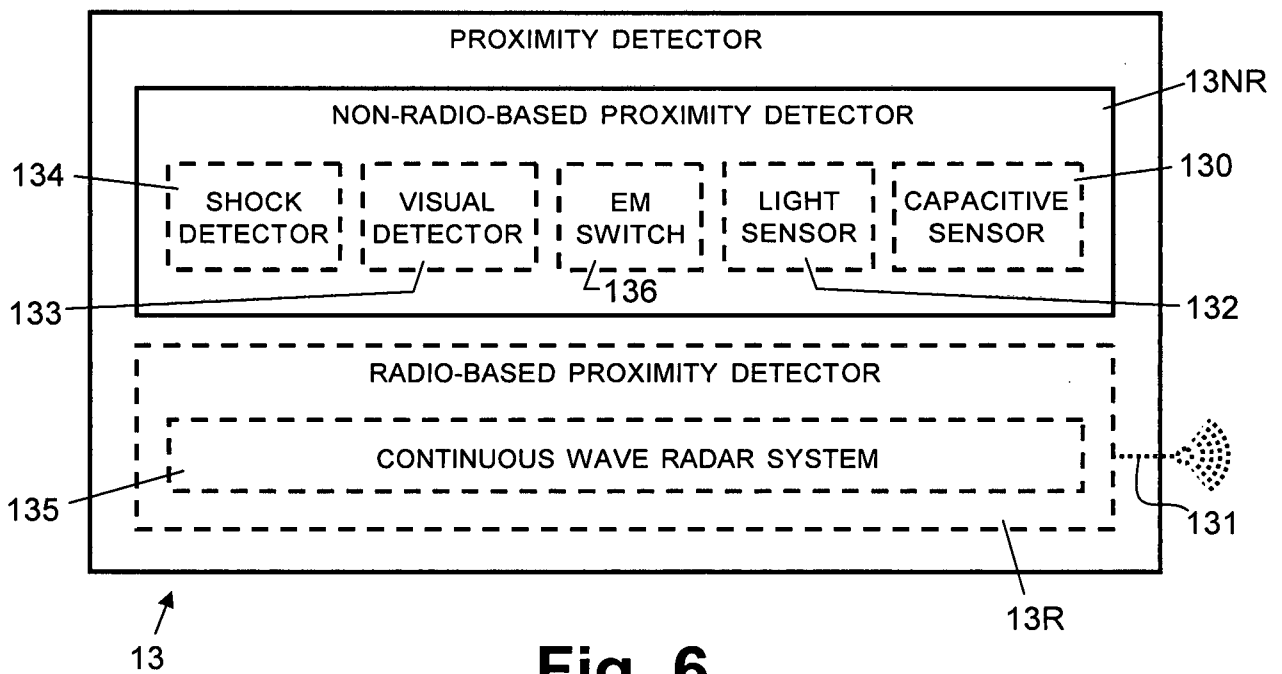

Fig. 6

ACCESS CONTROL DEVICE

ELECTRONIC LOCK

CONT-
ROLLER

PROXIMITY
DETECTOR

RADIO COMMUNICATION
MODULE

MOBILE DEVICE

ACCESS
CONFIRMATION
MODULE

PROCESSOR

RADIO
COMM. MODULE

14

12

11

13

10

131

130

111

3

23

22

21

1

2

P

C

S

