

No. 772,908.

PATENTED OCT. 18, 1904.

C. RIDDERHOF & G. E. MILES.

FLASHING DEVICE FOR INCANDESCENT ELECTRIC LAMPS.

APPLICATION FILED DEC. 9, 1903.

NO MODEL.

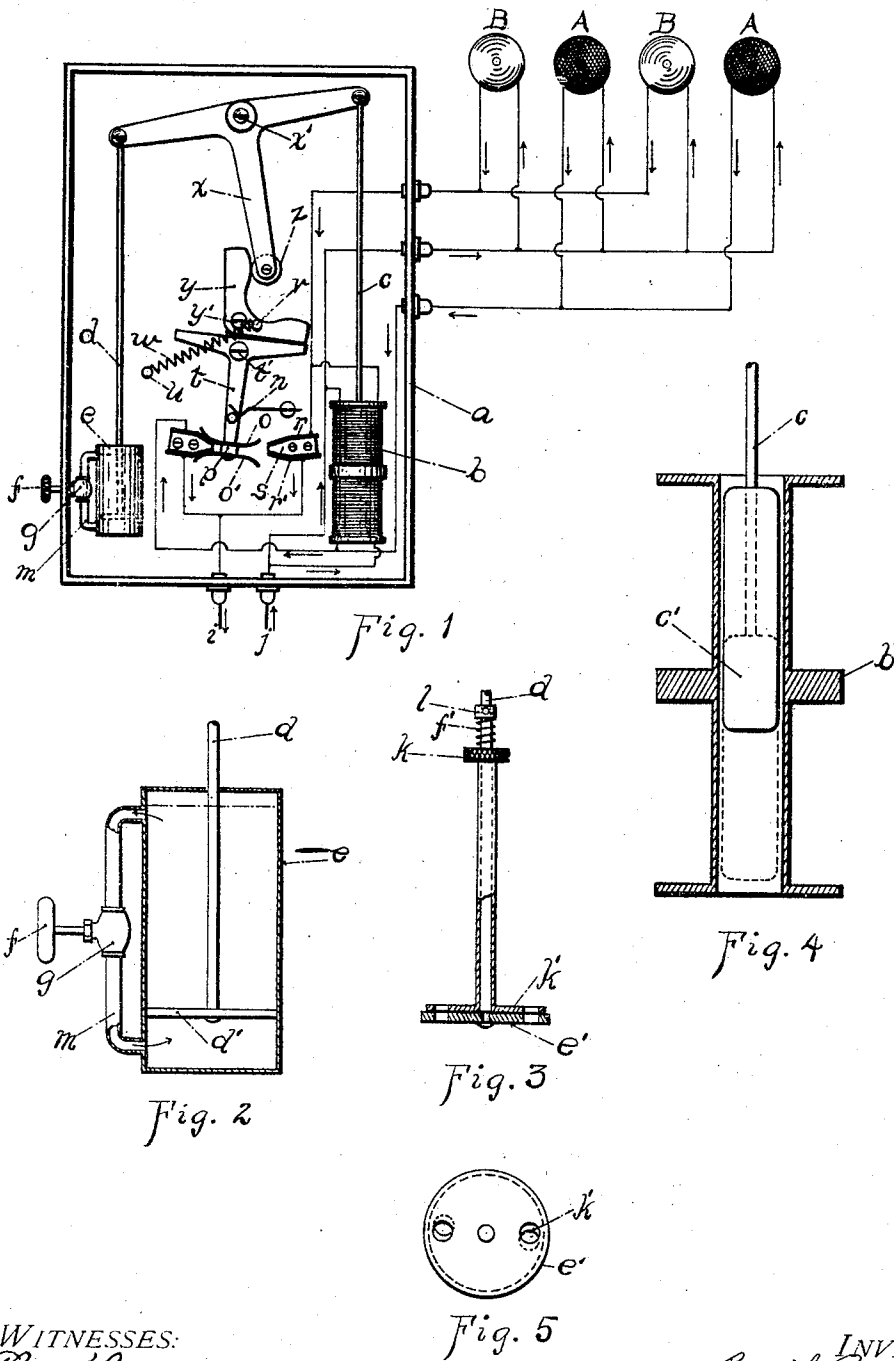

WITNESSES:
Ben F. Barendsen
Evert Smits

INVENTORS
Cornel Ridderhof
Greyson E. Miles
 BY
Glenn J. Dewart
 Attorney

UNITED STATES PATENT OFFICE.

CORNEIL RIDDERHOF AND GREYSON E. MILES, OF GRAND RAPIDS, MICHIGAN, ASSIGNORS TO WILMARTH & MORMAN COMPANY, OF GRAND RAPIDS, MICHIGAN, A CORPORATION.

FLASHING DEVICE FOR INCANDESCENT ELECTRIC LAMPS.

SPECIFICATION forming part of Letters Patent No. 772,908, dated October 18, 1904.

Application filed December 9, 1903. Serial No. 184,511. (No model.)

To all whom it may concern:

Be it known that we, CORNEIL RIDDERHOF and GREYSON E. MILES, citizens of the United States, residing at Grand Rapids, in the county of Kent and State of Michigan, have invented a new and useful Improvement in Flashing Devices for Incandescent Electric Lamps, of which the following is a specification.

Our invention relates to improvements in flashing devices for incandescent electric lamps; and its objects are, first, to provide a device simple and automatic requiring no independent rotary motor with commutator and which being compact and portable can be located in any convenient place; second, to provide a device requiring a minimum amount of electric power in its operation; third, to provide such an arrangement of electric circuits in such flashing device that there will be practically no sparking at the switches or circuit-changing mechanisms; fourth, to provide a switch or circuit-changing mechanism by which the circuit will be broken very quickly independent of the speed of the parts actuating said switch or mechanism; fifth, to provide an easy and convenient method of adjusting the speed of the flashing mechanism without any necessity of opening the case containing such mechanism, and many other objects, which appear further in this specification.

The details of our invention are more particularly pointed out in the claims hereto, and a structure embodying its mechanical features is clearly shown in the accompanying drawings, in which—

Figure 1 is a general view of our invention, showing the lid or cover of the frame of our device removed and the plan of electric-light circuits outlined. Fig. 2 is a sectional view of the speed-regulating cylinder of our invention. Fig. 3 is a view of a modified form of a portion of our speed-regulating device. Fig. 4 is a sectional view of the spool or core of our double solenoid and the soft-iron bar therein.

Similar letters of reference refer to like parts throughout the several figures.

In a suitable frame or case, which we have designated as *a*, Fig. 1, we have mounted vertically a double solenoid *b*. Within this solenoid is suspended the soft-iron bar *c'*, attached to the connecting wire or rod *c*. This soft-iron bar is adapted to reciprocate within the two coils of said double solenoid. When the mechanism of our device is in the position shown in Fig. 1, the soft-iron bar *c'* is in the position shown in Fig. 4, at the upper limit of its travel, the dotted lines in this figure indicating the position of said iron bar when at the lower limit of its travel.

In the upper portion of the frame or case for our device we have placed the walking-beam lever *x*, pivoted at *x'*, to the right extension of which we have attached pivotally the supporting wire or rod *e*. Thus it will be readily seen that as the soft-iron bar *c'* passes up and down in the course of the operation of our device this walking-beam lever will have an oscillating motion. Toward the lower portion of the frame will be seen two switches or circuit opening and closing devices interposed in two electric-lamp circuits, which we have shown leading toward two sets of incandescent lamps at the right of our device in Fig. 1. We have shown the main feed-wires entering the frame at *i* and *j*, Fig. 1, the direction of the electric current being indicated by the arrows which we have distributed along said circuits.

s represents non-conducting wedge-shaped blocks, upon the inclined faces of which are placed the metallic plates *r* and *r'* in electrical connection with the wires of said circuits, as shown. The circuit completing and breaking device is composed of the T-shaped lever *t*, pivotally mounted in said frame at *t'*, the vertical extension of which lever is adapted to carry the contact-fingers *o* and *o'*, which are firmly secured to the extremity of said T-shaped lever, in the manner as shown, said contact-fingers being held apart by the metallic washer *p*. *n* is a detent-spring which is adapted to cooperate with a pin in said T-shaped lever and hold said lever in normal positions. When in the position shown in Fig. 1, said de-

tent-spring *n* holds the left projections of said contact-fingers *o* and *o'* firmly in contact with the plates upon the left wedge-shaped block, thus completing the electric circuit upon which
 5 are the lamps A, Fig. 1. It will be noted that by reason of the position of said contact-fingers *o* and *o'* and the arrangement of the inclined faces of the contact-plates *r* and *r'* the points of contact in said switches will be kept
 10 clean, and at the same time but little power is required in breaking contact. In close proximity to said T-shaped lever *t* is pivotally mounted the V-shaped lever *y*, pivoted at *y'*. *v* is a pin extending from said lever *y* and to
 15 which is attached the tension-spring *w*. Upon a downwardly-projecting arm from said walking-beam lever *x* is mounted the roller *z*, which is adapted to contact with the inside faces of the arms of said V-shaped lever *y*, as shown.
 20 The operation of the device which we have already described is as follows: With the parts in the positions shown in Fig. 1, the electric circuit being completed in the circuit upon which are the lamps A, and inasmuch as the
 25 lower solenoid is connected in multiple with this circuit, a magnetic influence is exerted upon said soft-iron bar *c'* from below, and it is drawn downwardly. This causes the roller *z*
 30 to force said lever *y* to the left until such a point is reached where said spring *w* exerts a tension upon the side of the pivot *y'* opposite to that shown in Fig. 1. When this position
 35 shall have been reached, said V-shaped lever snaps suddenly over to the limit of its travel to the left, the left arm of said lever *y* contacting with a hammer-blow upon the left extension of said T-shaped lever *t*. This drives
 40 the portion of said lever *t* carrying the contact-fingers to the right, where it is held by said detent-spring *n*. When the parts are in this position, said fingers *o* and *o'* contact with
 45 the plates *r* and *r'* upon the right wedge-shaped block and the circuit upon which are the lamps B is completed, the upper solenoid becomes operative, and the reverse action of
 50 the parts takes place. By reason of the fact that the said solenoids are connected in multiple with the respective lamp-circuits the high-tensioned current occasioned by the
 55 breaking of the electric circuit as the fingers *o* and *o'* pass back and forth is received by the lamps, which may be in multiple with said solenoid, and there is practically no arc or spark at said switching device. It will be noted
 60 that the spring *n* holds said fingers *o* and *o'* firmly in contact with the plates upon each of said wedge-shaped blocks and that said switching-lever *t* moves from one normal position to the other only under the hammer-blows it
 65 receives from the arms of said V-shaped lever and that the making and breaking of said circuits is accomplished suddenly.

The speed with which the above-described operations take place is governed by the device which we have shown at the left side of

Fig. 1, a detail of which is shown in Fig. 2. This device consists of a cylinder *e* and the piston *d'*, fitted therein, the rod *d* connecting said piston to said walking-beam lever *x*.
 70 The chambers of said cylinder into which it is divided by said piston *d'* are connected, preferably, by means of the tube *m*, in which is the shut-off cock *g*, with the finger-piece *f*,
 75 extending outside of the frame *a*. We prefer to fill this cylinder with oil, although if the parts are closely fitted this would not be necessary, and it will be readily seen that the size of the opening in said tube *m* will determine the speed at which the piston *d'* can be
 80 raised and lowered.

A modification of this device for governing the speed of the piston is shown in Fig. 3, wherein said opening between the chambers of said cylinder is in the piston itself, and this can be opened and closed by turning the
 85 thumb-piece *h*, *d* being the rod connecting said piston with the walking-beam lever, and *h'* being a plate with openings which align with the openings in said piston *d'*. Fig. 5 shows
 90 a bottom view of Fig. 3, with the plate *h'* turned slightly, so that said opening in said piston *d'* is partially closed.

Our invention will admit of many deviations without departing from its essential features. Our solenoids may be connected in series with
 95 the respective circuits and connected in multiple with any non-inductive resistance to prevent the sparking. For convenience we have shown the two circuits with three wires, one
 100 being common to both. However, these two circuits may be made up with two independent wires each or flexible cords leading from our device, which, being small and compact, may be placed in any convenient place.

Having thus described our invention, what we claim as new, and for which we desire Letters Patent, is—

1. In an incandescent-lamp flashing device, the combination of the frame *a*; the feed-wires *i* and *j*; two electric-lamp circuits connecting with said feed-wires, each lamp-circuit having therein a switch composed of the wedge-shaped piece *s* of non-conducting material, the metallic plates *r* and *r'* upon the inclined faces of said wedge-shaped pieces, and the double spring-fingers *o* and *o'* adapted to contact with each of said plates *r* and *r'* upon said pieces *s* alternately; a T-shaped lever pivotally mounted in said frame *a* at *t'*, the vertical portion thereof carrying the double contact-fingers *o* and *o'*, in metallic contact with each other; a pin upon said T-shaped lever, and the detent-spring *n* contacting therewith; a V-shaped lever *y* pivotally mounted in said frame *a* at *y'*, the extending
 120 arms of which lever *y* are adapted to contact alternately with the horizontal cross-piece of said T-shaped lever; a tension-spring connected to said V-shaped lever at *v*, and extending toward the apex of said V-shaped lever *y* in
 130

line with the pivotal point thereof when said lever y is central between the two extremes of its swinging travel; the walking-beam lever x pivotally mounted in said frame a at x' having a downwardly-projecting arm carrying the roller z which is adapted to contact with the inside faces of the arms of said V-shaped lever y , alternately; two solenoids b mounted vertically one over the other, in said frame a , each of which solenoids is connected in multiple, to said lamp-circuits respectively; a soft-iron bar adapted to be actuated by said solenoids; connections between said iron bar and one end of said walking-beam lever x ; a cylinder mounted in said frame a ; the piston d' in said cylinder; the piston-rod d connecting with said walking-beam lever x ; the tube m connecting the chambers of said cylinder as divided by said piston; the shut-off cock or valve g in said tube; and means for opening and closing said shut-off cock g outside of the frame a ; the parts all coacting for the purpose specified and substantially as described.

2. In an incandescent-lamp flashing device, the combination of a suitable frame or case for said device; electric feed-wires entering said frame; two electric-lamp circuits connecting with said feed-wires, each of said lamp-circuits having therein a switch composed of a wedge-shaped piece of non-conductive material, metallic plates upon the wedge-surfaces of said non-conductive pieces, and spring-fingers adapted to contact with said plates upon said wedge-shaped pieces alternately; a T-shaped lever pivotally mounted in said frame, and carrying said spring contacting-fingers; a pin upon said T-shaped lever, and a detent-spring n adapted to contact with said pin; a V-shaped lever mounted pivotally in said frame, the arms or extensions of said V-shaped lever being adapted to contact with the cross-piece of said T-shaped lever, alternately; a tension-spring connected to said V-shaped lever and extending toward the apex of said V-shaped lever, and in line with the pivotal point of said lever when the same is central between the extremes of its swinging travel; a walking-beam lever pivotally mounted in said frame, and having a downwardly-projecting arm carrying a roller adapted to contact with the inside faces of the arms of said V-shaped lever, alternately; two solenoids vertically mounted in said frame, each of which is connected in multiple to said lamp-circuits, respectively; a soft-iron bar adapted to be actuated by said solenoids; connections between said iron bar and one end of said walking-beam lever; a cylinder mounted in said frame, and a piston adapted to fit said cylinder; connections between said piston and said walking-beam lever; a tube connecting the chambers of said cylinder as formed by said piston; a shut-off cock or valve in said tube, and

means for operating the same outside of the said frame, substantially as described.

3. In an incandescent-lamp flashing device, the combination of a suitable frame for said device; electric feed-wires entering said frame; two electric-lamp circuits connecting with said feed-wires, each of said lamp-circuits having therein a switch composed of a wedge-shaped piece of non-conductive material, metallic plates upon the wedge-surfaces of said non-conductive pieces, and spring-fingers adapted to contact with said plates upon said wedge-shaped pieces, alternately; a T-shaped lever pivotally mounted in said frame, and carrying said spring contacting-fingers; a detent device adapted to hold said T-shaped lever in normal positions; a V-shaped lever pivotally mounted at or near its apex, in said frame, the arms or extensions of which V-shaped lever are adapted to contact with the cross-piece of said T-shaped lever, alternately; a spring connected to said V-shaped lever, and extending toward its apex, and in line with the pivotal point of said V-shaped lever, when the same is central between the extremes of its swinging travel; a walking-beam lever pivotally mounted in said frame, and having a downwardly-projecting arm carrying a roller adapted to contact with the inside faces of the arms of said V-shaped lever, alternately; two solenoids vertically mounted in said frame, each of which is connected in multiple to said electric-lamp circuits, respectively; a soft-iron bar adapted to be actuated by said solenoids; connections between said iron bar and one end of said walking-beam lever; a cylinder mounted in said frame, and a piston adapted to fit said cylinder; connections between said piston and said walking-beam lever; a tube connecting the chambers of said cylinder as formed by said piston; a shut-off cock or valve in said tube, and means for operating the same, outside of said frame, substantially as described.

4. In an incandescent-lamp flashing device, the combination of a suitable frame for said device; electric feed-wires entering said frame; two electric-lamp circuits connecting with said feed-wires, each of said lamp-circuits having therein a switch; a T-shaped lever pivotally mounted in said frame, and carrying a contacting device adapted to cooperate with said switches alternately; a detent device adapted to hold said T-shaped lever in normal positions; a V-shaped lever pivotally mounted at or near its apex in said frame, the arms or extensions of which V-shaped lever are adapted to contact with the cross-piece of said T-shaped lever, alternately; a spring connected to said V-shaped lever and extending toward its apex, and in line of its said pivot when said V-shaped lever is central between the extremes of its swinging travel; a walking-beam lever pivotally mounted in said frame, and having a downwardly-projecting

arm carrying a roller adapted to contact with the inside faces of said V-shaped lever, alternately; two solenoids mounted in said frame, vertically, each of which is connected in multiple to said lamp-circuits, respectively; a soft-iron bar adapted to be actuated by said solenoids; connections between said soft-iron bar and said walking-beam lever; a cylinder mounted in said frame, and a piston adapted to fit said cylinder; connections between said cylinder and said walking-beam lever; a tube connecting the chambers of said cylinder as formed by said piston; a shut-off cock or valve in said tube, and means for operating the same outside of said frame, substantially as described.

5. In an incandescent-lamp flashing device, the combination of a suitable frame of said device; electric feed-wires entering said frame; two electric-lamp circuits entering said frame and connecting with said feed-wires, each of said lamp-circuits having therein a switch; a T-shaped lever pivotally mounted in said frame, and carrying a contacting device adapted to cooperate with said switches, alternately; a detent device adapted to hold said T-shaped lever in normal positions; a V-shaped lever pivotally mounted at or near its apex, in said frame, the arms or extensions of said V-shaped lever being adapted to contact with the cross-piece of said T-shaped lever, alternately; a spring connected to said V-shaped lever, and extending toward its apex, and in line with the said pivot of said V-shaped lever when the same is central between the extremes of its swinging travel; a walking-beam lever pivotally mounted in said frame, and having a downwardly-projecting arm carrying a roller adapted to contact with the inside faces of the arms of said V-shaped lever; two solenoids vertically mounted in said frame, each of which is connected in multiple to said lamp-circuits, respectively; a soft-iron bar adapted to be actuated by said solenoids; connections between said iron bar and said walking-beam lever; a cylinder mounted in said frame, and a piston adapted to fit said cylinder; connections between said piston and said walking-beam lever; an opening between the chambers of said cylinder formed by said piston, and means for adjusting the size of said opening, substantially as described.

6. In an incandescent-lamp flashing device, the combination of a suitable frame for said device, electric feed-wires entering said frame; two electric-lamp circuits connecting with said feed-wires, each of said lamp-circuits having therein a switch; a T-shaped lever pivotally mounted in said frame, and carrying a contacting device adapted to cooperate with said switches, alternately; a detent device adapted to hold said T-shaped lever in normal positions; a V-shaped lever pivotally mounted at or near its apex in said frame, the arms or

extensions of which V-shaped lever are adapted to contact with the cross-piece of said T-shaped lever, alternately; a spring connected to said V-shaped lever, and extending toward its apex, and in line with the pivot of said V-shaped lever when the same is central between the extremes of its travel; a walking-beam lever pivotally mounted in said frame, and having a projecting arm, adapted to contact with the inside faces of the arms or extensions of said V-shaped lever, alternately; two solenoids mounted in said frame, each of which is connected in multiple to said lamp-circuits, respectively; a soft-iron bar adapted to be actuated by said solenoids; connections between said soft-iron bar and said walking-beam lever; a cylinder mounted in said frame, and a piston adapted to fit said cylinder; connections between said piston and said walking-beam lever; and an opening between the chambers of said cylinder as formed by said piston, and means for adjusting the size of said opening, substantially as described.

7. In an incandescent-lamp flashing device, the combination of a switching-lever; a detent for holding the same in normal positions; a vibratory plate or lever held under spring tension at either limit of its vibratory travel and adapted to contact with said switching-lever when at such limit of travel; and means for automatically shifting said vibratory plate or lever back and forth beyond the neutral point of said spring tension on the same, substantially as described.

8. In an incandescent-lamp flashing device the combination of a suitable frame for said device, electric feed-wires entering said frame, two electric-lamp circuits connected with said feed-wires, each of said lamp-circuits having therein a switch; a lever carrying a contact device adapted to cooperate with said switches alternately; means for suddenly changing the positions of said lever from one switch to the other, and a detent for holding said lever in normal positions; two solenoids mounted in said frame, one adjacent to the other, each of which solenoids is connected in multiple to said lamp-circuits respectively; a soft-iron bar adapted to be actuated by, and reciprocate between said solenoids; connections between said soft-iron bar and said means for changing the normal positions of said lever carrying said actuating device; and means for regulating the speed of the reciprocatory travel of said soft-iron bar substantially as described.

9. In an incandescent-lamp flashing device, the combination of electric feed-wires, two electric-lamp circuits connected with said feed-wires each of said lamp-circuits having therein a switch; means for suddenly opening and closing said switches alternately, consisting of a T-shaped lever pivotally mounted upon a suitable support and carrying metallic contact-pieces adapted to cooperate with said

switches alternately; a detent for holding said
 T-shaped lever in normal positions, a V-shaped
 lever pivotally mounted at or near its apex,
 the angular extensions of which V-shaped lever
 being adapted to contact alternately with
 5 the cross-piece of said T-shaped lever, a spring
 for holding said V-shaped lever in normal po-
 sitions, two solenoid-coils mounted one adja-
 cent to the other, an iron bar or armature
 10 adapted to reciprocate between them, an actu-
 ating-lever adapted to contact with said V-
 shaped lever and swing same from one normal
 position toward the other, connections be-
 tween said iron bar or armature and said ac-
 15 tuating-lever; and means for regulating the
 speed of said reciprocatory travel of said iron
 bar or armature, substantially as described.

10. In an incandescent-lamp flashing device,
 the combination of electric feed-wires, two
 20 electric-lamp circuits connected with said feed-
 wires, each of said lamp-circuits having there-
 in a switch; means for suddenly opening and
 closing said switches alternately consisting
 25 of a T-shaped lever pivotally mounted upon a
 suitable support, and adapted to open and close
 the metallic circuit in said switches alter-
 nately, a detent for holding said T-shaped lever
 in normal positions, a V-shaped lever piv-
 30 otally mounted at or near its apex, the angu-
 lar extension of which V-shaped lever being
 adapted to contact alternately with the cross-
 piece of said T-shaped lever, a spring for
 holding said V-shaped lever in normal posi-
 35 tions, two solenoid-coils mounted one adja-
 cent to the other, an iron bar or armature
 adapted to reciprocate between them, an ac-
 tuating-lever adapted to contact with said V-

shaped lever and swing the same from one
 normal position toward the other, connec-
 tions between said iron bar or armature and
 40 said actuating-lever, and means for regulat-
 ing the speed of the reciprocatory travel of
 said iron bar or armature substantially as de-
 scribed.

11. In an incandescent-lamp flashing device 45
 the combination of electric feed-wires, two
 electric-lamp circuits connected with said feed-
 wires, each of said lamp-circuits having there-
 in a switch; means for suddenly opening and
 closing said switches alternately consisting 50
 of a switching-lever pivotally mounted upon a
 suitable support and adapted to open and close
 the metallic circuit in said switches alter-
 nately, a vibratory member pivotally mount-
 55 ed near said switching-lever, and adapted to
 contact with said switching-lever and drive
 same from one limit of its travel to the other,
 a spring for holding said vibratory member
 in normal positions, an actuating-lever adapt-
 60 ed to contact with said vibrating member and
 force same from one normal position toward
 the other, and a soft-iron bar or armature con-
 nected to said actuating-lever adapted to re-
 ciprocate between two solenoids substantially
 as described. 65

In testimony whereof we have signed our
 respective names to this specification in the
 presence of two subscribing witnesses.

CORNEIL RIDDERHOF.
 GREYSON E. MILES.

Witnesses:

EVERT SMITS,
 B. M. DE VLIJGER.