

E. C. RICHARDSON. Churn-Cover.

No. 224,305.

Patented Feb. 10, 1880.

Fig. 1.

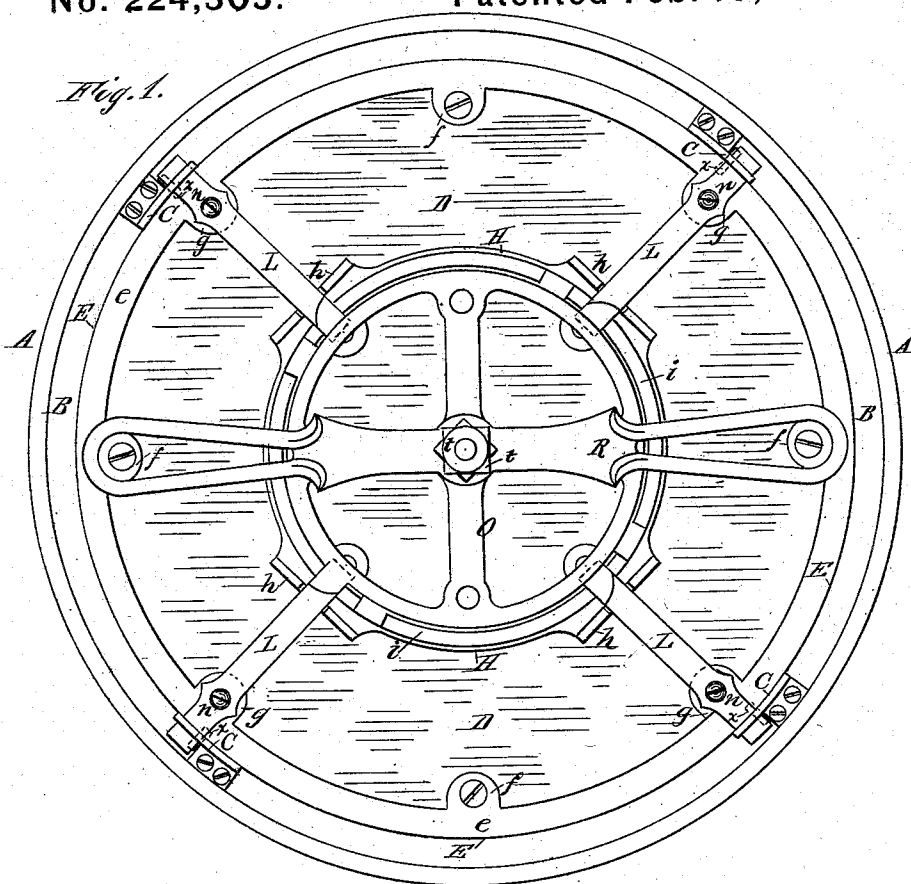
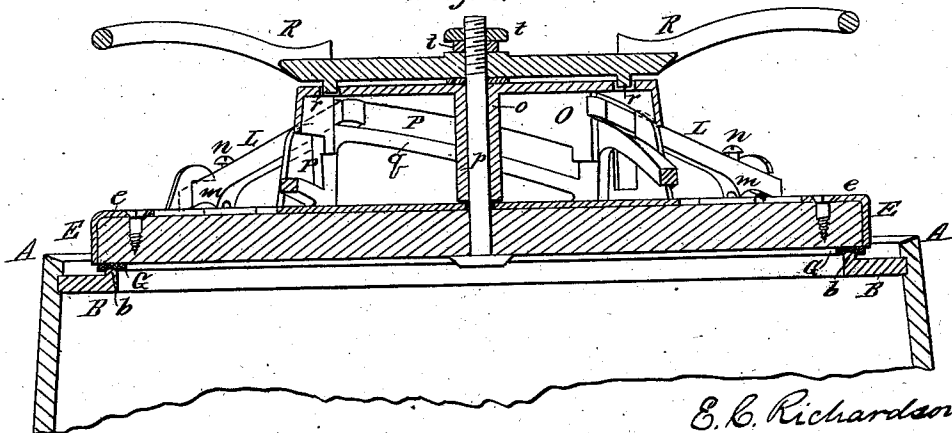

Fig. 2.



Attest:
 Charles Searle.
 A. Godfrey

E. C. Richardson,
 Inventor:
 By Worth Ogden,
 Attorney.

E. C. RICHARDSON.
Churn-Cover.

No. 224,305.

Patented Feb. 10, 1880.

Fig. 3.

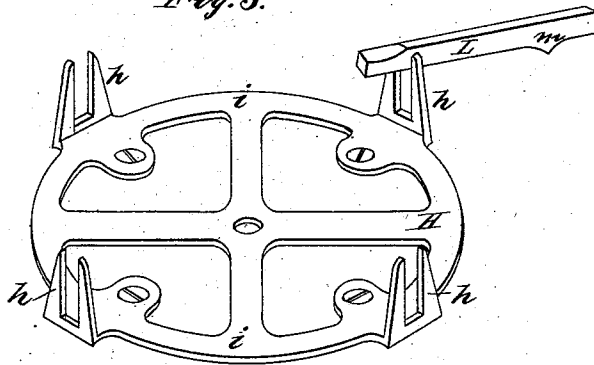
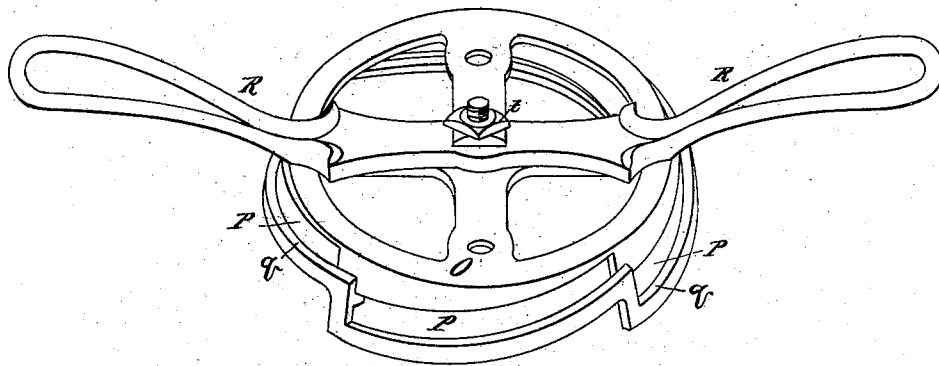

Fig. 4.



Attest:
 Charles K. Searle.
 A. Godfrey.

E. C. Richardson,
 Inventor:
 By Wood, Osgood,
 Attorney.

UNITED STATES PATENT OFFICE.

EDWIN C. RICHARDSON, OF POULTNEY, VERMONT.

CHURN-COVER.

SPECIFICATION forming part of Letters Patent No. 224,305, dated February 10, 1880.

Application filed November 14, 1879.

To all whom it may concern:

Be it known that I, EDWIN C. RICHARDSON, of Poultney, county of Rutland and State of Vermont, have invented certain new and useful Improvements in Churn-Covers, &c., of which the following is a full, clear, and exact description, reference being had to the accompanying drawings, and to the letters of reference marked thereon.

Figure 1 is a plan view of a churn-head with my improvements applied thereto, and Fig. 2 is a vertical axial section of the same upon a plane passing through two of the levers. Fig. 3 is a perspective view, showing the central plate with its slotted lever-guides, the operating-cam being omitted and only one of the holding-levers being indicated as resting in the slot provided for it. Fig. 4 is a perspective view of the operating-cam detached from the other parts, and showing its preferred form and construction.

Like letters of reference in all the figures wherever they occur indicate corresponding parts.

My improvements are peculiarly applicable to that class of devices known as "barrel-churns," wherein it is desirable to secure the removable head firmly in place; but they may also be applied to any other barrels or vessels for analogous purposes.

The object of the invention is to produce a simple, cheap, and easily-operating device, by means of which the barrel or churn head may be effectively and quickly secured in its proper place, be incapable of accidental disarrangement, and at the same time be readily detachable whenever desired, while the device is strong, durable, not liable to get out of order, and capable in its several parts of accommodating itself to the wear upon either, so as to always insure a perfectly tight joint between the cover and barrel or other vessel.

To accomplish all of this the invention consists in certain novel and useful arrangements of construction, all of which will be hereinafter first fully described, and then pointed out in the claims.

A represents the barrel-chine or the open mouth of the churn or other vessel upon which it is desired to secure the cover against acci-

dental displacement and against possible leakage. Upon this is mounted the ordinary and well-known open metallic ring-head B, having a bead, *b*, against which the packing-gasket is brought to bear. This ring is usually made of iron, (galvanized or otherwise,) and might be dispensed with. Its use is preferred, however, for obvious reasons. Upon it I locate and firmly secure four upwardly-extending lugs, hooks, or ears, C C, &c., having their overhanging parts all turned in the same direction and being symmetrically disposed about the ring-head. These hooks not only serve to secure the ends of the holding-levers, but they also operate as guides, by means of which the cover is made to automatically assume its proper position upon the ring when dropped in between them.

The cover D is made of wood in the usual manner, and surrounded at its edge by a metallic rim, E, the upper part, *e*, of which extends a little distance over the upper exposed surface, and is provided with ears *f f* at suitable distances for the reception of screws, by which it may be firmly held in place. Other ears, *g g*, &c., serve as rests or fulcrums for the operating-levers. This form of angular binding for the edge of the cover is found to operate successfully in preventing warping thereof, without the addition of inwardly-extending arms or other metallic adjuncts, such as are usually employed, and it forms an admirable protection against damage to the cover by reason of contact with the hooks C or other objects during use or handling.

A packing-gasket, G, of cork or other suitable material, is secured upon the under side of the cover, for purposes well understood.

Centrally upon the top of the cover I secure the light open-work plate H, having the slotted ears *h* extending upwardly a sufficient distance to form guides for holding and directing the ends of the holding-levers. The rim *i* of this plate H forms a bed or track for the cam-block to travel upon.

The holding-levers L are enlarged, as at *m*, for the purpose of permitting a sufficient movement in them, and they are secured in place by simple wood-screws *n*, passing down through the fulcrums and entering the material of the cover. The perforations through the levers for

the accommodation of screws n are somewhat enlarged, so as to permit the necessary movement in the levers, and the upper and under surfaces of their inner ends are slightly inclined, to facilitate the movement of the cam-surfaces thereover.

The cams for controlling the movements of the levers are formed in a light open framework or block, O , having a central hub, o , through which the retaining-bolt p passes. P , P , &c., are the cam-slots in the outer wall of frame O . They are formed therein in the casting, the lower ledges, g , which serve to elevate the inner ends of the levers, being set out from the upper part in order to facilitate the manufacture.

The cam is cut with a pretty rapid incline, so that the movements of the levers will be sufficiently rapid, while at the same time all necessary power is provided for and the slipping of the cams obviated by not making the incline too great.

The lower wall of each cam rides upon the rim i , before referred to, the hub o bearing upon the central part of plate H , and by use of the central bolt, p , keeping the cam-block always in proper position.

The handle R is provided with a couple of pins, r , which fit in corresponding perforations in the top of the cam-frame, and it is held in place and firmly connected with the cam-frame by means of suitable nuts t , which also serve to maintain all the working parts against displacement.

The several parts being constructed substantially in accordance with the foregoing description, and being assembled for use, as indicated in Figs. 1 and 2, the cover is raised by the handle R and simply dropped into place between the hooks C . Then, to firmly lock or secure it, it is only necessary to twist the handle toward the left. This operation will bring the outer ends of the levers up against the vertical walls of the hooks, the pins X , which are inserted through the depending flange of the metallic rim, first striking against the lower part of the hooks, and thus relieving the levers of the shock which would otherwise result from the adjustment. The further turning of the handle and connected cam will depress the inner ends of the levers, elevating their outer or locking ends and forcing them hard against the projecting parts of the hooks, thus securing the head or cover properly against leakage.

To remove the cover the handle is simply turned in the reverse direction. It first depresses the locking ends of the levers, and then, when these are free, turns the cover slightly, so as to remove them from under the hooks, after which the cover may be lifted off the ring-head.

In locking and unlocking the cover by use of this attachment it will be observed that no time is required to first secure the registering of any of the parts, as is the case in many forms of cover attachments wherein the locking-ears are used, especially such as employ

perforated ears, which require the particular and careful insertion of the locking-levers.

The leverage afforded by the operating-cams and the lever-bars L is amply sufficient to enable one to secure the cover with any desired degree of firmness. These lever-bars might be varied in number and might be connected with the cover at the fulcrum in a variety of ways which will readily be suggested. They should, however, be incapable of being accidentally unseated, and in order to secure all the advantages of my improvements they should, in being worked for the purposes intended, move in vertical planes, as herein indicated. The cams might be reversed, when, of course, it would be necessary to reverse the position of the locking-hooks upon the ring-head or chine. The use of four locking-levers and operating-cams has been found most desirable; but more might be employed, if desired.

By constructing the locking device in the manner specified, it will appear upon consideration that any usual wear upon any of the parts will not affect the efficiency of the device, because of the great extent of leverage afforded, which, if lost by wear of one part, will be replaced by a corresponding wear in another. All springs are dispensed with, which results in less liability to damage, and any of the parts, if broken, can be easily and quickly replaced by others; and generally the improved device admirably answers all the purposes or objects of the invention, as previously stated.

I desire to add that I am fully aware of numerous forms of devices for securing covers in place, wherein the locking-levers are operated by screws and springs, and wherein such levers are thrust outwardly and inwardly in a radial direction with respect to the cover. To these old forms I desire it understood that I make no claim; but,

Having now fully described my invention, what I do claim as new, and desire to secure by Letters Patent, is—

1. The combination, with the open ring-head, of the hooks mounted thereon and left open at one side, the vertically-moving levers pivoted to the cover, and the cam-block adapted to rock said levers in a vertical direction, the arrangement being substantially such as described, so as to permit the ready locking and unlocking, as shown and set forth.

2. The angular rim for the cover, provided with ears to facilitate attachment and with fulcrums or rests for the levers, which are pivoted thereto and secured thereon, substantially as described, so that they may be moved in vertical directions and prevented from moving in radial directions, as shown and set forth.

3. The central bearing-plate for the cam-frame, secured to the cover, the same being provided with upwardly-extending slotted ears for guiding and holding the levers, and serving as a bed or track upon which the cam-frame travels, substantially as shown and described.

4. The combination of the vertically-moving

levers pivoted to the cover, the central bearing-plate having the slotted guiding-ears, the cam-frame secured upon said plate by the central bolt, and the locking-ears upon the ring-head or chine, the whole being constructed and arranged to operate substantially as shown and described.

5
10
15
20
5. In combination with the cam-frame, the handle R, with its attached lugs, and the central bolt and nuts, substantially as shown and described.

6. In a cover-locking device, the locking-levers L, enlarged as at *m*, and pivoted to the cover in the manner explained, the same being combined with operating-cams and with the open locking-hooks, substantially as shown and described.

7. The herein-described cam frame or block having the perforated walls and the central hollow hub, the same being combined with the

locking-levers and mounted and secured in the central plate, substantially as shown.

8. The herein-described cover-locking device, consisting of the open hooks mounted upon the ring-head or chine, the vertically-moving levers pivoted to the cover, the central plate having the slotted guiding-ears, the open-work cam-frame with central hub, the connected handle, and central securing-bolt, these several parts being constructed, combined, and arranged substantially in the manner shown and described.

In testimony that I claim the foregoing I have hereunto set my hand in the presence of two witnesses.

EDWIN C. RICHARDSON.

Witnesses:

MARVIN O. STODDARD,
CYRUS GATES.