

(12) INTERNATIONAL APPLICATION PUBLISHED UNDER THE PATENT COOPERATION TREATY (PCT)

(19) World Intellectual Property

Organization

International Bureau

(43) International Publication Date

05 January 2023 (05.01.2023)



(10) International Publication Number

WO 2023/274802 A1

(51) International Patent Classification:

F24F 8/108 (2021.01) F24F 8/30 (2021.01)

F24F 8/20 (2021.01) F24F 8/90 (2021.01)

(21) International Application Number:

PCT/EP2022/066980

(22) International Filing Date:

22 June 2022 (22.06.2022)

(25) Filing Language:

English

(26) Publication Language:

English

(30) Priority Data:

21183050.0 01 July 2021 (01.07.2021) EP

(71) Applicant: BLUEAIR AB [SE/SE]; Karlavägen 108, 115
26 Stockholm (SE).

(72) Inventor: NETHAJI, Alagirisamy; Unilever Innovation
Centre Wageningen B.V., Bronland 14, 6708 WH Wagenin-
gen (NL).

(74) Agent: NEWBOULD, Frazer, Anthony; Bronland 14,
6708 WH Wageningen (NL).

(81) Designated States (unless otherwise indicated, for every
kind of national protection available): AE, AG, AL, AM,
AO, AT, AU, AZ, BA, BB, BG, BH, BN, BR, BW, BY, BZ,
CA, CH, CL, CN, CO, CR, CU, CZ, DE, DJ, DK, DM, DO,
DZ, EC, EE, EG, ES, FI, GB, GD, GE, GH, GM, GT, HN,
HR, HU, ID, IL, IN, IQ, IR, IS, IT, JM, JO, JP, KE, KG, KH,
KN, KP, KR, KW, KZ, LA, LC, LK, LR, LS, LU, LY, MA,
MD, ME, MG, MK, MN, MW, MX, MY, MZ, NA, NG, NI,
NO, NZ, OM, PA, PE, PG, PH, PL, PT, QA, RO, RS, RU,
RW, SA, SC, SD, SE, SG, SK, SL, ST, SV, SY, TH, TJ, TM,
TN, TR, TT, TZ, UA, UG, US, UZ, VC, VN, WS, ZA, ZM,
ZW.

(84) Designated States (unless otherwise indicated, for every
kind of regional protection available): ARIPO (BW, GH,
GM, KE, LR, LS, MW, MZ, NA, RW, SD, SL, ST, SZ, TZ,
UG, ZM, ZW), Eurasian (AM, AZ, BY, KG, KZ, RU, TJ,
TM), European (AL, AT, BE, BG, CH, CY, CZ, DE, DK,
EE, ES, FI, FR, GB, GR, HR, HU, IE, IS, IT, LT, LU, LV,
MC, MK, MT, NL, NO, PL, PT, RO, RS, SE, SI, SK, SM,
TR), OAPI (BF, BJ, CF, CG, CI, CM, GA, GN, GQ, GW,
KM, ML, MR, NE, SN, TD, TG).

Declarations under Rule 4.17:

— as to applicant's entitlement to apply for and be granted a
patent (Rule 4.17(ii))

Published:

— with international search report (Art. 21(3))

(54) Title: AIR PURIFIER

(57) Abstract: An air purifier comprising n air flow generator, a motor for said fan, a removable filter, and a HINS light source and wherein said HINS light source emits light with a peak wavelength of from 390 to 398 nm.



WO 2023/274802 A1

AIR PURIFIER

The present invention relates to an air purifier with improved performance.

5

Air purifiers work by filtering ambient air through a filter. Accordingly, anything in the air is in theory capturable by the filter. While there are different types of filtration means, from particulate filter to gas filter, it is a necessary consequence of the functioning of an air purifier that they also capture microbes caught in the air flow.

10

It is also a routine feature of air purifiers that the main focus is removing pollution from the ambient air and various sensors which indicate that particulates are being removed exist. Consequentially, it also is quite routine for an air purifier to work in an automatic mode whereby the presence of particulates influences the air flow speed through the device. Thus, when the air quality is good, it is possible and often desirable that the purifier is maintained in idle or stand-by mode to conserve energy.

15

However, when air is not passing through the purifier micro-organisms caught by the filter are able to grow quickly and form biofilms which can have a deleterious effect on effective filter life span and also cause a health hazard to the users who habit the domestic setting.

20

US 2019/167833 (Yang Chin-Huei) discloses an air purifier, comprising: a upper cover, having at least one grid column on front terminal of the upper cover; a bottom cover, having at least one grid column on front terminal of the bottom cover; and two groups of ultraviolet light emitting diodes (LEDs), respectively having a heat sink and a ultraviolet light emitting diode (LED), wherein the ultraviolet LED is mounted on the heat sink, and a wavelength range of the ultraviolet LED is between 100 nm and 480 nm; wherein the grid column on front terminal of the upper cover is combined with the grid column on front terminal of the bottom cover to form a column hole through which an air flows out.

25

30

KR 102 204 085 (Cha Byeong Ho) discloses an air purifying apparatus with a sterilizing function, comprising: a main body (110) having one side surface on which an inlet (111) is formed, the other side surface on which an outlet (112) is formed, and the inside in which a purification space (113) communicating with the inlet (111) and the outlet (112) is formed and an installation hole (114) communicating with the purification space (113) is arranged; a suction fan (120) introducing external air through the inlet (111) while being driven to rotate in the main body (110); a filter unit (130)

35

arranged in the main body (110) to filter foreign materials of the introduced air; and a sterilizing ray module (140) mounted in the installation hole (114) and having a UV ray panel (141) arranged at the position directed toward the purification space (113) to emit UV sterilization rays toward the air passing through the purification space (113). The sterilizing ray module (140) is detachably
5 mounted in the installation hole (114) while being formed with size to be capable of being gripped by the hand, and has a battery (142) embedded to supply a driving power source to the UV ray panel (141) so as to emit the UV sterilization rays toward a polluted object (10) in a state of being separated from the installation hole (114).

10 KR 2020 0044333 (LG Innotek CO Ltd) discloses A purification device according to one embodiment comprises a photocatalyst filter; and a light source module which emits light to the photocatalyst filter to activate a photocatalytic reaction. In the light source module, the wavelength of light whose relative intensity is the strongest among wavelengths of emitting lights is 380 to 420 nm. The photocatalyst filter comprises tungsten oxide. The light source module can be spaced a
15 predetermined distance apart from the photocatalyst filter. According to the present invention, heat dissipation properties can be improved by natural convection.

US 2019/125904 (Weeks) discloses systems and methods for pulsing high intensity narrow spectrum light are provided. In one example embodiment, a lighting system includes can include
20 one or more high intensity narrow spectrum light sources configured to emit high intensity narrow spectrum light. The lighting system can further include a power circuit configured to provide power to the one or more high intensity narrow spectrum light sources and a pulsing circuit configured to control delivery of power to the one or more high intensity narrow spectrum light sources so as to pulse the emission of high intensity narrow spectrum light from the one or more high intensity
25 narrow spectrum light sources.

Despite the prior art there remains a need for improved air purifiers, in particular air purifiers which are more hygienic throughout their working life.

30 Accordingly, and in a first aspect, there is provided an air purifier comprising n air flow generator, a motor for said fan, a removable filter, and a high intensity narrow spectrum (HINS) light source.

The HINS light used in the invention is preferably provided by a light emitting diode (LED) system. By HINS light is meant light having a peak wavelength in the range of about 392 nm to about
35 398 nm, preferably from 393 nm to about 397 nm, and most preferably at 395 nm.

An example of a suitable light source is a 395 nm light emitting diode (LED) array (ENFIS PhotonStar Innovate UNO 24; PhotonStar Technologies, UK) powered by a 40 V LED Driver. The array has a peak wavelength around 395 nm and a bandwidth of approximately 19 nm but will, for convenience, be referred throughout as 395 nm light.

5

We have surprisingly found that a HINS light source at from 392 to 398 nm is capable of playing a key role in the purification of air. Not only is this narrow band of light is capable of reducing filter contamination but the HINS light source has no impact on the structural integrity of the filters. Accordingly, the HINS light source can be employed close to the removable filters in air purifiers so as to efficiently decontaminate filters without any negative impact on the filter's structural integrity and so filtration performance. In contrast it is well known that other light sources such as UV damage the filters when they are employed to decontaminate them.

10

The ability to decontaminate without materially affecting the structural integrity of the filters makes such means highly attractive.

15

Preferably, said HINS light source emits light with an average wavelength of from 392 to 398 nm or more preferably from 393 to 397 nm. The most preferred peak wavelength is 395 nm.

20

Preferably, the HINS light source may be employed singularly or in a group of light sources. Many light sources may be used to emit light to bathe as much of the interior surfaces of the purifier, in particular the filter, in light of the appropriate wavelength as possible.

Preferably, the HINS sources are selected and disposed such that the light intensity at the removable filter is from 800 to 5000 lux, preferably from 1000 to 4000 lux.

25

Preferably, the HINS light source is disposed after the fan in an air flow direction.

Preferably, the HINS light source is disposed between the fan and the filter in an air flow direction.

30

The light source in such an embodiment will be directed to emit light towards the removable filter during use so as to bathe the filter in light having the desired wavelength.

However it is also possible for the HINS light source to be disposed after the filter in an air flow direction so long as the light sources are directed towards the filter. The light source would also be decontaminating the air pulled through the filter should any micro-organisms remain in the air flow unfiltered by the filter.

35

Preferable the HINS light source is disposed from 2 to 50 cm from the filter.

We have also surprisingly found that subjecting a surface to an air draft and then to HINS light, or *vice versa*, provides enhanced sterilisation characteristics.

5

Preferably, the removable filter media may be a particulate filter or gas filter while it is also possible that both a particulate and gas filter may be simultaneously employed.

10

The air flow speed measured at the removable filter is known in the art as the media velocity. Media velocity is the velocity at which the air travels through the filter. Media velocity has to be controlled perfectly to ensure that the maximum amount of particles are trapped. Too fast and many of the pollutants fly straight through unfiltered. Too slow and the purifier is not reaching the farthest corners of your room quickly enough to be effective.

15

Preferably, the air purifier comprises an ioniser.

The ioniser used comprises an emitter electrode and a ground electrode. The emitter electrode discharges an ion cloud between the emitter and the receiver on application of a suitable voltage, preferably from -10 to 10kV but more preferably around the range -8 to 8kV.

20

The emitter electrode is preferably a point, tip or multiple tips or points for example a brush and is in electrical communication with a voltage source. Preferably, the emitter electrode is within 20cm, more preferably 15cm, especially preferably 10 cm and most preferably up to 5 cm from the nearest filter medium to be sterilised by bathing it in an ion cloud during activation of the ioniser when
25 required. This distance is the distance from the tip of the emitter electrode to the nearest part of nearest filtration medium, more specifically the part of the filter medium which filters rather than for example a structural frame.

30

The receiving electrode is preferably a metallic part in the shape of a ring so that the resulting ion cloud is in three dimensions as the ions are spent away from the emitter and are then pulled towards the receiver. Preferably, the receiving electrode is in the form of a cage which extends away from the emitting electrode in an air flow direction. More preferably, the receiving electrode is in the form of a reticulated arrangement and which extends towards the filter. Such extension may present a hemispherical or partial cylindrical shape such that the receiving electrode is downstream
35 in an air flow direction from the emitting electrode.

Preferably, the emitter is centrally disposed between a receiver in the form of a ring. The emitter may be disposed pointing towards or away from the air flow during use but it is preferred that the emitter is pointed towards the surface to be sterilised, for example, an internal wall or a filter medium.

5

Preferably, the air flow generator generates an air flow commensurate with sterilisation of an internal surface of the air purifier and/or a filter media for a period of from 1 second to 10 hours.

10 In a second aspect there is provided a method for sterilising a removable filter in an air purifier by subjecting the filter to HINS light.

In a third aspect there is provided a method for sterilising a removable filter in an air purifier by (A) subjecting said removable filter to an air draft, and (B) subjecting said filter to HINS light.

15 Preferably, (A) and (B) are carried out exclusively. By this is meant that the surface to be sterilised is first subjected to an air draft and then when the air draft is stopped, the surface is exposed to a burst of HINS light. Similarly, the HINS light may come before the air draft.

20 Preferably, the filter is also subjected to (C) a burst of ionisation from an optional ioniser. The ionisation may come before or after either or both of (A) and (B).

It is also preferred that the sequence of air draft and then HINS light, or vice versa, is repeated such that the surface to be sterilised is subjected to both air draft and HINS light on an intermittent basis.

25 Preferably, (A) has a duration of from 1 min to 10 hours
Preferably, (B) has a duration of from 1 min to 10 hours
Preferably, (C) has a duration of from 1 min to 10 hours.

30 We have surprisingly found that by providing an air draft, preferably a low air draft, and then a burst of HINS light, or *vice versa*, we can drastically reduce micro-organism viability on the internal surfaces of the air purifier and in particular on the filter media. While the purifier is operating there is no increased risk of micro-organisms growing and multiplying on the filter as the air flow through the filter is such that micro-organisms are destroyed by the dehydrating environment. However, when the air purifier is in idle or stand-by mode and the conditions are favourable, the micro-organisms
35 grow.

In a fourth aspect there is provided an air purifier comprising a removable particulate or gas filter, an air flow generator, a means for controlling said air flow generator, a first air flow setting with an air filtration air flow speed and a second air flow setting which correlates with sterilisation of an internal surface of the air purifier and/or removable particulate or gas filter and a light source which emits
5 HINS light.

Preferably, the air purifier comprises an operable mode for sterilising an internal surface or a filter medium and whereby the air draft corresponds with said second air flow setting and this is activated either before or after a period of bathing in HINS light.

10

We have surprisingly found that a combination of a modest air flow rate with HINS light treatment can prevent growth of micro-organisms and drastically reduce the prevalence of live micro-organisms being blown into the ambient air and also released into the environment during filter change.

15

Such micro-organisms include gram positive bacteria, gram negative bacteria, spores, moulds and fungi as well as any viruses within said micro-organisms.

Preferably, the air flow (A) speed (media velocity) measured at the removable filter is at least
20 0.1 cms^{-1} measured at the filter medium. The measurement at the filter medium is taken from the spatial centre point on the fan side of the filter media surface. Where there is more than one filter medium, the one taken for the air draft measurement is the one which is closest to the air flow generator and so receives the air draft first.

25 More preferably, the air flow speed measured at the removable filter is from 0.1 to 2.5 cms^{-1} . Most preferably, the air flow speed measured at the removable filter is from 0.8 to 1.2 cms^{-1} . This is known as 'low air draft' as it is below the ordinary media velocity used for air filtration.

In preferred embodiments of the invention the purifier ascertains the likelihood of conditions
30 conducive to micro-organism growth and when such conditions are deemed to exist it actuates the air flow generator and/or the light source emitting HINS light to destroy the microbes on the filter, or even those on the internal surfaces of the purifier.

When the processor determines that the conditions are conducive to micro-organism growth, for
35 example with reference to inputs from a temperature sensor and a humidity sensor and then with reference to an appropriate look-up table, it either provides an indication, for example by way of a

visual or audible signal, or electronically to a remote device such as a mobile phone so that the user is notified that the air flow generator should be employed, or it automatically actuates the fan or impeller at a low speed as described herein, or the ioniser, and which is sufficient to prevent micro-organism growth or to directly destroy the micro-organisms. It is important to note that this activation
5 of the ioniser or fan is appropriate only when the device is in stand-by mode or idle. When the ioniser is functioning or when the fan is functioning no micro-organism can grow on the filter. Preferably, the purifier has first mode in which the choices are either: no action, where the conditions determined by the humidity sensor and temperature sensor are such that no or low micro-organisms growth is anticipated; an alert by way of an electronic signal to a mobile device to
10 alert the user that conditions are favourable to micro-organisms and permitting the option for the user to actuate the fan; and a warning level where the user is warned that micro-organism growth is likely and strongly recommending to the user to actuate the fan or impeller, or the HINS light source.

A second mode may operate similarly in that indications are made determined by the input from the
15 temperature and humidity sensors but instead of a warning or an alert, the machine is automatically turned on when conditions are such that micro-organism growth is likely.

The user of course may select one of these two modes where appropriate.

20 When the processor determines that the conditions are conducive to micro-organism growth it either provides an indication, for example by way of a visual or audible signal, or electronically to a remote device such as a mobile phone so that the user is notified that the air flow generator and/or ioniser should be employed.

25 Temperature sensors are known in the art and are commercially available from Sensirion. Suitable examples of temperature sensors include STS3x series.

Humidity sensors are known in the art and are commercially available from Sensirion. Suitable
30 examples of humidity sensors include SHT3x series.

In a preferred embodiment the means for controlling the air flow generator and/or light source based on input from said sensors is conducted automatically, for example by a processor. In such an embodiment the sensors sense the temperature and/or humidity on a continuous or intermittent basis and send information back to the processor. The processor determines whether the
35 conditions are conducive to micro-organism growth based on at least temperature or humidity. Preferably, the processor determines whether the conditions are conducive to micro-organism

growth based on temperature and humidity. More preferably, the processor determines the likelihood of micro-organism growth additionally based on parameters such as geographical location, time of the day, week, month or season or even the pollution levels as well as any specific conditions that occur, for example virus pandemics or bush fires, and combinations of any of these.

5

For example, in Asia, the wet seasons are typically defined by the monsoon and occurs in the summer. In contrast the summer in Europe and North America is characterised by drier weather. Similarly, the hemispheres have different seasonal characteristics.

10 Preferably, the geographical location is determined by GPS or through the purifiers WIFI capability. It may also be provided by way of user input during a set-up process.

The purifier is powered by any suitable power source including internal sources, e.g. batteries, and external power sources. The power is used to drive a motor which in turn powers at least the air
15 flow generator and the ioniser where present.

Preferably, the filter media comprises at least one of carbon, activated carbon, a non-woven, a thermoplastic, a thermosetting material, a porous foam, fibreglass, paper, a high loft spunbound web, a low loft spunbound web, a meltblown web and or a bi-modal fiber diameter meltblown
20 media.

Preferably, the removable particulate filter is a High Efficiency Particulate Air (HEPA) filter. It is to be understood that while the filter part of an air purifier is a vital part of its function, air purifiers are not commonly manufactured with a filter in place. They are practically always manufactured separately
25 and most importantly often by a different commercial enterprise than of the manufacturer of the air purifier itself. It is also typical for a manufacturer of filters to manufacture filters for different air purifier models made by different manufacturers. The particulate filter is to be contrasted with the pre-filter or any dust filter which is present. Pre-filters and dust filters are not considered HEPA filters as they do not have the particulate capturing capability exhibited by HEPA filters. Preferably, the filter is pre-
30 charged before application to the air purifier.

Pre-filters are filters which have a low air resistance and also function as a poke guard, preventing the user from touching the volute or impeller assembly. The pre-filters are not intended to exhibit any major effect in the context of air purification. They do not have the air resistance or particle
35 entrainment capability of dedicated particulate filters. Preferably the pre-filter is not a HEPA filter.

The purifier of the inventions also comprises a fan or impeller. The fan may be a bladeless fan, an axial fan but it is preferred that the fan is a radial fan.

5 Preferably, the air purifier comprises an ioniser. Preferably, the ioniser comprises a corona discharge tip and a receiving electrode. When the corona discharge tip is subjected to an appropriate electric voltage it generates an ion cloud between the tip and the receiving or ground electrode.

10 The ioniser is preferably disposed on the interior of said purifier. However, it is also preferred that the purifier comprises an ioniser additionally disposed on the exterior of said device. More preferably, it is preferred that any external ioniser is disposed at the top of the device. Locating the external ioniser at the top of the device means that domestic dust particles are ionised as they fall through the air towards the ground and are therefore more likely to aggregate as they become charged. As they become more aggregated they are more easily caught up in the air circulation
15 pattern created by the device and so more easily filtered.

Where the ioniser is disposed in the interior of the device it is preferred that it is located before the removable particulate filter in an air flow direction.

20 Preferably, the device comprises an interior ioniser and an exterior ioniser. The exterior ioniser facilitating aggregation of domestic dust particles and the interior ioniser facilitating capture of the aggregated dust particles by the removable particulate filter. In both instances the ionisation permits less dense filtration media and low air speed (fan) speeds.

25 In a preferred embodiment the air purifier comprises, in an air flow direction, a fan, a HINS light source, and a removable filter.

30 Preferably, the HINS light source is disposed so as to bathe the removable filter in HINS light when the light source is operating. Preferably, the HINS light source is sufficiently close to the removable filter to destroy micro-organisms during operation. Preferably, at least one HINS light source is from 1 to 20cm from the closest removable filter, more preferably from 2 to 12 cm.

35 Preferably, the air flow generator is housed within a volute and more preferably, said ioniser is disposed at or near an outlet on the volute.

Preferably, the volute comprises an air flow outlet through which air flows from the air flow generator towards the removable filter medium, said outlet being defined by a perimeter and preferably comprising a receiving electrode and an associated emitting electrode such that between said receiving and emitting electrode there is formed an ion cloud when emitting electrode is subjected to an appropriate voltage. The receiving electrode may thus be disposed around a portion or all of the perimeter of the outlet. In a preferred embodiment the emitting electrode or corona discharge tip is disposed substantially centrally in the outlet such that air flowing from the volute and towards the removable filter or filters is subjected to an ion cloud.

In a preferred embodiment, the air purifier comprises a first and second removable filter medium angled with respect to one another such that there exists an acute angle between said first and second media, said acute angle facing an air flow direction, and said purifier comprising an ioniser which during use generates an ion cloud between said first and second filter media. In such an embodiment the filters are bathed in an ion field. While in ordinary circumstances the ion cloud is intended to ionise any particles entrained within the air flow we have surprisingly found that the ion cloud alone provides significant sterilisation of the filter media and internal surfaces of the purifier. This is particularly useful when the purifier is in stand-by mode or turned off whether to conserve energy or merely because the user believes that the air quality is sufficiently good. The ioniser uses considerably less energy than the air flow generator and so it is thus possible to maintain sterile conditions internally without having to turn on the fan.

Preferably, the emitting electrode is disposed substantially between an imaginary line between a proximal end of said first and second filter medium, said proximal ends being towards the air flow generator. In such an embodiment the air purifier comprises a pair of filter media angled relative to one another such that they form an acute angle between them. In such an embodiment it is preferred that the apex ends of the filter media are touching or are close to one another so that they present an inverted book arrangement with the tip pointing in an air flow direction and the proximal ends of the filter media facing towards the air flow generator.

Preferably, the ioniser is disposed substantially between the proximal ends of the filter media such that the filter media are bathed in an ion field in use. More preferably, the emitting electrode emits an ion stream in an air flow direction.

Embodiments of the invention will now be described with reference to the following in which figure 1 shows a cross section of an embodiment.

In detail, figure 1 shows an air purifier (1) comprising a housing (2) and a fan (3) contained in a volute (4). The fan (3) is shown in simplified form with no attempt made to describe its physical characteristics or placement. The volute (4) comprises an outlet (5) through which air is passed from the fan (3) to the filters (6). The filters (6) are connected at their top edges (7) to form an apex.
5 The volute outlet (5) also comprises a HINS light source (14) for generating a HINS light which is directed towards the filters (6) and an ion emitter (9) for creating an ion cloud during use between the emitter (9) and the receiver (8).

In use, air passes from ambient into the purifier through air inlets (10) which are secured with pre-
10 filters (12) which act as an initial filter preventing large items entrained in the air flow from entering and blocking the internal mechanics of the device but also acting as a poke guard.

An air flow is then generated by the fan (3) and the air passes through the volute and towards the
15 filters (6) where it is cleaned.

The air then passes out through the outlets (13). Similarly, the outlets (13) are also secured with a
pre-filter (11).

Figure 2 is a schematic showing how the HINS light generated by the HINS light source bathes the
20 filters in HINS light in use. Shown is the volute (4) and an LED HINS light source (14) which generates HINS light when an appropriate voltage is applied. Also shown is the ion emitter (9) and the ion cloud (20).

The HINS light (21) extends away from the LED HINS light source (14) and bathes the filters (6)
25 and provides a sterilisation effect.

EXAMPLE

HINS illumination sources peak wavelength maxima at 395nm and 405nm were tested. Following
tests were carried out to test the efficacy of the two HINS sources:

Effect of exposure time on the germ inactivation efficacy

A 200uL microbial suspension containing Staphylococcus Aureus was loaded on a 5 x 5 cm
polypropylene based air filter (H11 grade). The suspension contained 0.1% Tween20 in order to
ensure proper wetting of the liquid suspension in the filter media. The filter media were exposed to
35 the 405nm HINS source such that a uniform light intensity of 4000lux units was incident on the
surface of the media. The test was carried out at 3 different exposure periods viz., 2h, 3h and 4h.

The temperature and humidity during the test were maintained at 25degC and 50-60% relative humidity respectively. After the exposure, the microbes were extracted from the filter using a saline solution by a 2min vortexing process. The log germ inactivation of HINS was calculated from the germ counts extracted from the samples after HINS exposure and comparing it against the germ counts extracted from the filter sample immediately after loading the germs. The control tests were carried out under the same conditions without HINS exposure.

The below table shows the logarithmic germ inactivation at the various exposure periods tested.

Time (h)	Logrithmic Germ Inactivation		
	Control	395nm HINS	405nm HINS
2	0.16	2.075	0.87
3	0.17	2.585	1.17
4	0.2	3.125	1.33

It can be observed that both the HINS sources were able to show a significant reduction in microbial levels as compared to the control tests. The 395nm HINS sources showed higher efficacy as compared to that of 405nm HINS source. Also, the performance of the 405nm source seems to saturate after 3h of exposure while the response of 395nm source remained linear in the time durations tested.

Further benefits are seen combining HINS with low air draft.

CLAIMS

1. An air purifier comprising an air flow generator, a motor for said air flow generator, a removable filter, and a High Intensity Narrow Spectrum (HINS) light source and wherein said HINS light source emits light with a peak wavelength of from 390 to 398 nm.
2. An air purifier according to claim 1 or 2 wherein said light source emits light with a peak wavelength of from 392 to 397 nm.
3. An air purifier according to any preceding claim comprising an ioniser.
4. An air purifier according to any preceding claim wherein the HINS light source comprises a light emitting diode (LED).
5. An air purifier according to any preceding claim wherein the HINS light source is disposed to bathe the removable filter in HINS light.
6. An air purifier according to any preceding claim wherein the light source is disposed after the fan in an air flow direction.
7. An air purifier according to any preceding claim wherein the light source is disposed between the fan and the filter in an air flow direction.
8. An air purifier according to any of claims 1-7 wherein the light source is disposed after the filter in an air flow direction.
9. A method for sterilising an air purifier comprising treating said purifier with HINS light with a peak wavelength of from 390 to 398 nm.
10. A method according to claim 9 comprising treating a removable filter of said air purifier with HINS light with a peak wavelength of from 390 to 398 nm.

Fig. 1

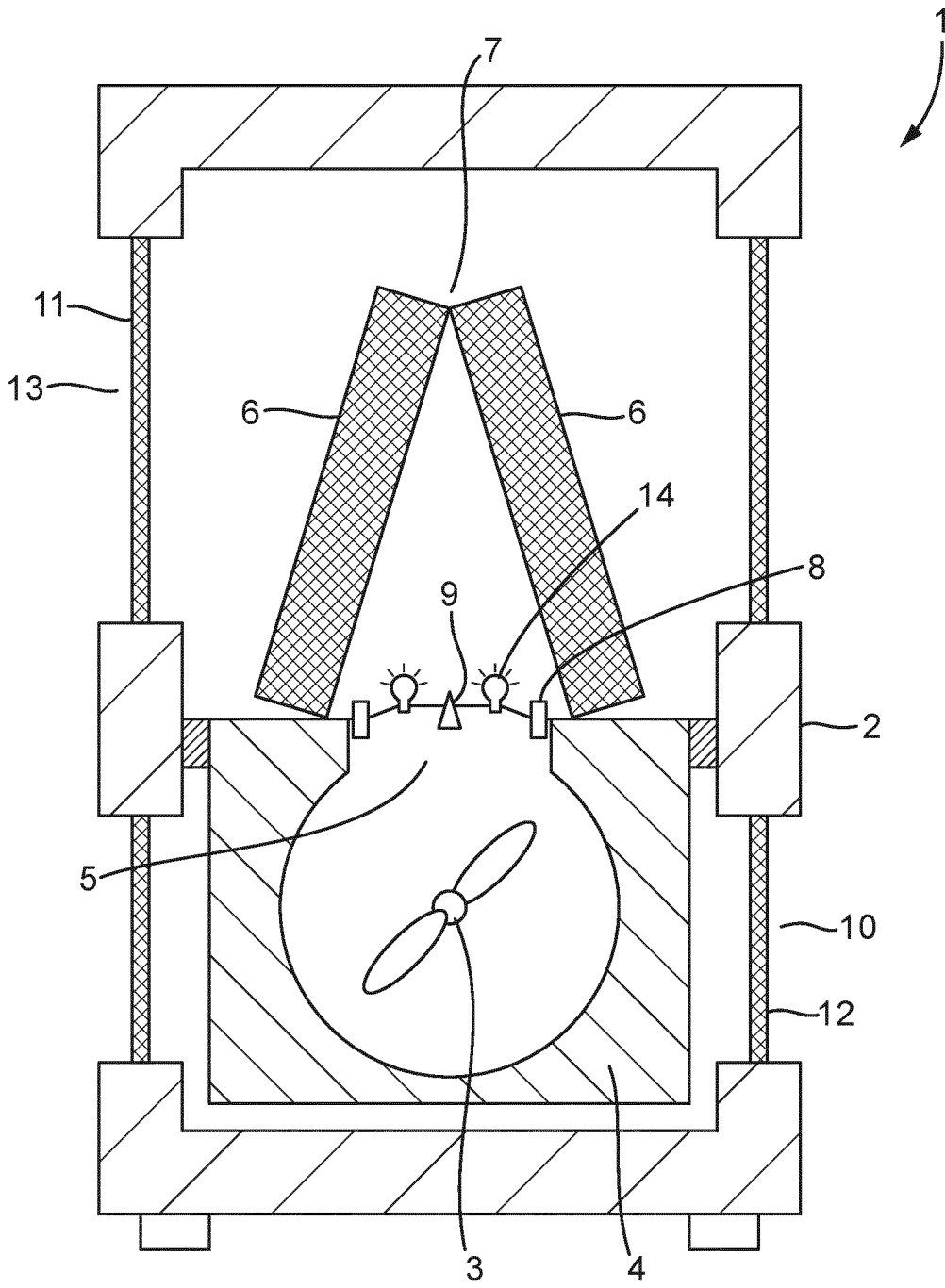
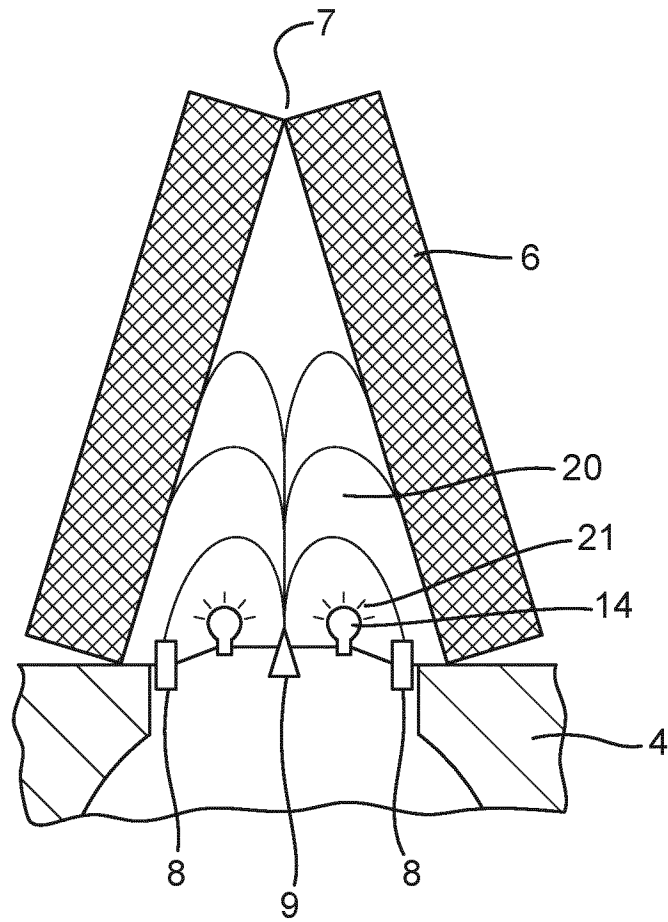

Fig. 2



INTERNATIONAL SEARCH REPORT

International application No
PCT/EP2022/066980

A. CLASSIFICATION OF SUBJECT MATTER
INV. F24F8/108 F24F8/20 F24F8/30 F24F8/90
ADD.

According to International Patent Classification (IPC) or to both national classification and IPC

B. FIELDS SEARCHED
 Minimum documentation searched (classification system followed by classification symbols)
F24F

Documentation searched other than minimum documentation to the extent that such documents are included in the fields searched

Electronic data base consulted during the international search (name of data base and, where practicable, search terms used)
EPO-Internal

C. DOCUMENTS CONSIDERED TO BE RELEVANT

Category*	Citation of document, with indication, where appropriate, of the relevant passages	Relevant to claim No.
X	US 2019/167833 A1 (YANG CHIN-HUEI [TW] ET AL) 6 June 2019 (2019-06-06) paragraphs [0005] - [0040]; figures 1-6 -----	1-10
A	KR 102 204 085 B1 (CHA BYEONG HO [KR]) 15 January 2021 (2021-01-15) paragraphs [0003] - [0051]; figures 1,2 -----	1-10
X	KR 2020 0044333 A (LG INNOTEK CO LTD [KR]) 29 April 2020 (2020-04-29) paragraphs [0003] - [0099]; figures 1,2 -----	1-3, 5-7, 9, 10
	-/--	

Further documents are listed in the continuation of Box C. See patent family annex.

* Special categories of cited documents :

"A" document defining the general state of the art which is not considered to be of particular relevance	"T" later document published after the international filing date or priority date and not in conflict with the application but cited to understand the principle or theory underlying the invention
"E" earlier application or patent but published on or after the international filing date	"X" document of particular relevance; the claimed invention cannot be considered novel or cannot be considered to involve an inventive step when the document is taken alone
"L" document which may throw doubts on priority claim(s) or which is cited to establish the publication date of another citation or other special reason (as specified)	"Y" document of particular relevance; the claimed invention cannot be considered to involve an inventive step when the document is combined with one or more other such documents, such combination being obvious to a person skilled in the art
"O" document referring to an oral disclosure, use, exhibition or other means	"&" document member of the same patent family
"P" document published prior to the international filing date but later than the priority date claimed	

Date of the actual completion of the international search 15 September 2022	Date of mailing of the international search report 26/09/2022
---	---

Name and mailing address of the ISA/ European Patent Office, P.B. 5818 Patentlaan 2 NL - 2280 HV Rijswijk Tel. (+31-70) 340-2040, Fax: (+31-70) 340-3016	Authorized officer Ismail, Youssef
--	--

INTERNATIONAL SEARCH REPORT

International application No
PCT/EP2022/066980

C(Continuation). DOCUMENTS CONSIDERED TO BE RELEVANT		
Category*	Citation of document, with indication, where appropriate, of the relevant passages	Relevant to claim No.
A	<p>BACHE S E ET AL: "Universal decontamination of hospital surfaces in an occupied inpatient room with a continuous 405 nm light source", JOURNAL OF HOSPITAL INFECTION, vol. 98, no. 1, 15 July 2017 (2017-07-15), pages 67-73, XP085314994, ISSN: 0195-6701, DOI: 10.1016/J.JHIN.2017.07.010 pages 67-73</p> <p style="text-align: center;">-----</p>	1-10
A	<p>US 2019/125904 A1 (WEEKS JR THOMAS WARREN [US]) 2 May 2019 (2019-05-02) paragraphs [0003] - [0077]; figure 1</p> <p style="text-align: center;">-----</p>	1-10

INTERNATIONAL SEARCH REPORT

Information on patent family members

International application No

PCT/EP2022/066980

Patent document cited in search report	Publication date	Patent family member(s)	Publication date
US 2019167833 A1	06-06-2019	TW M557344 U US 2019167833 A1	21-03-2018 06-06-2019
KR 102204085 B1	15-01-2021	NONE	
KR 20200044333 A	29-04-2020	NONE	
US 2019125904 A1	02-05-2019	NONE	