

April 2, 1935.

C. M. OTIS

1,996,253

DRYING TUMBLER

Filed July 17, 1931

2 Sheets-Sheet 1

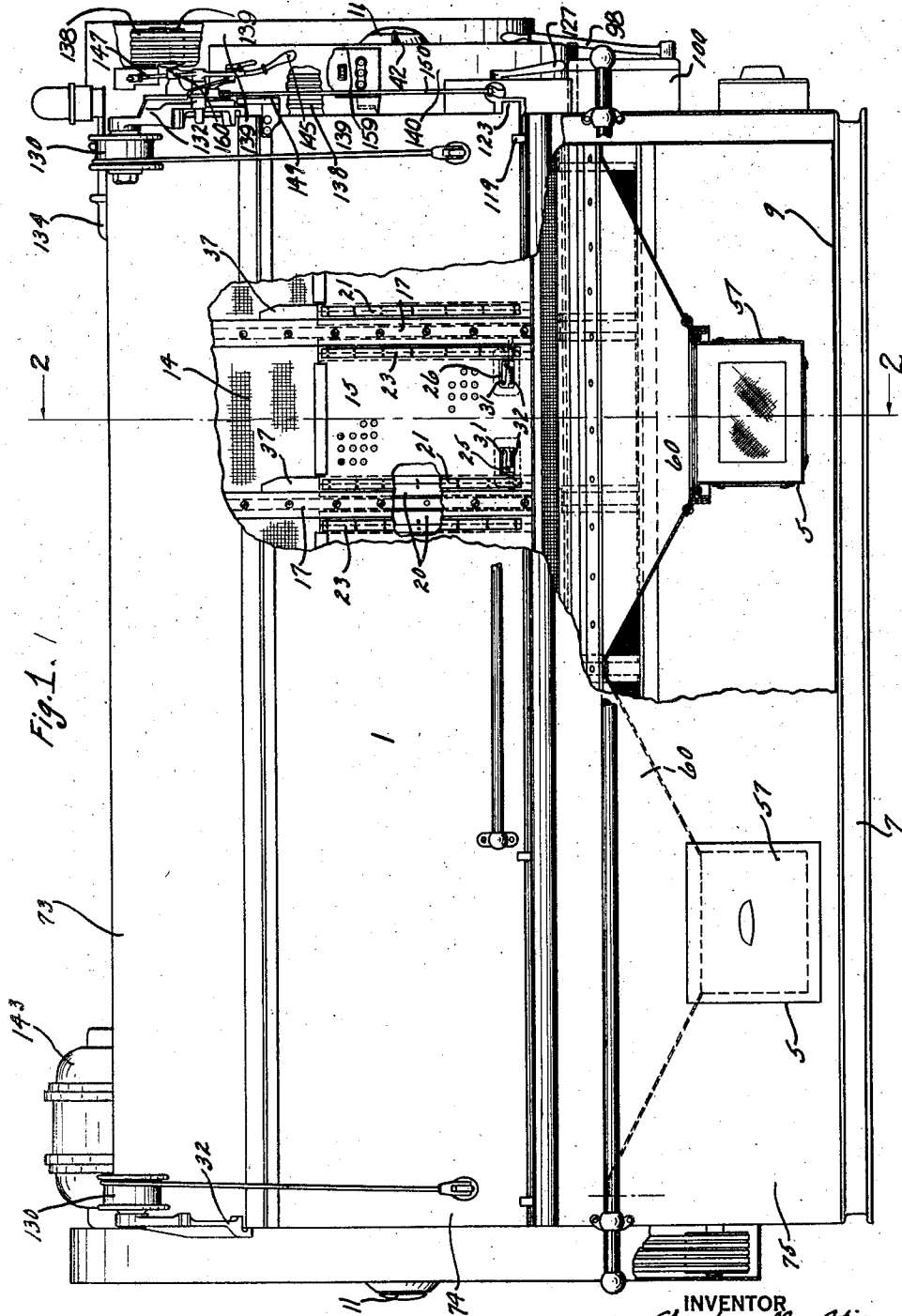

Fig. 1.

INVENTOR
Charles M. Otis

BY
Brockett, Hyde, Hapley & Meyer
ATTORNEYS

April 2, 1935.

C. M. OTIS

1,996,253

DRYING TUMBLER

Filed July 17, 1931.

2 Sheets-Sheet 2

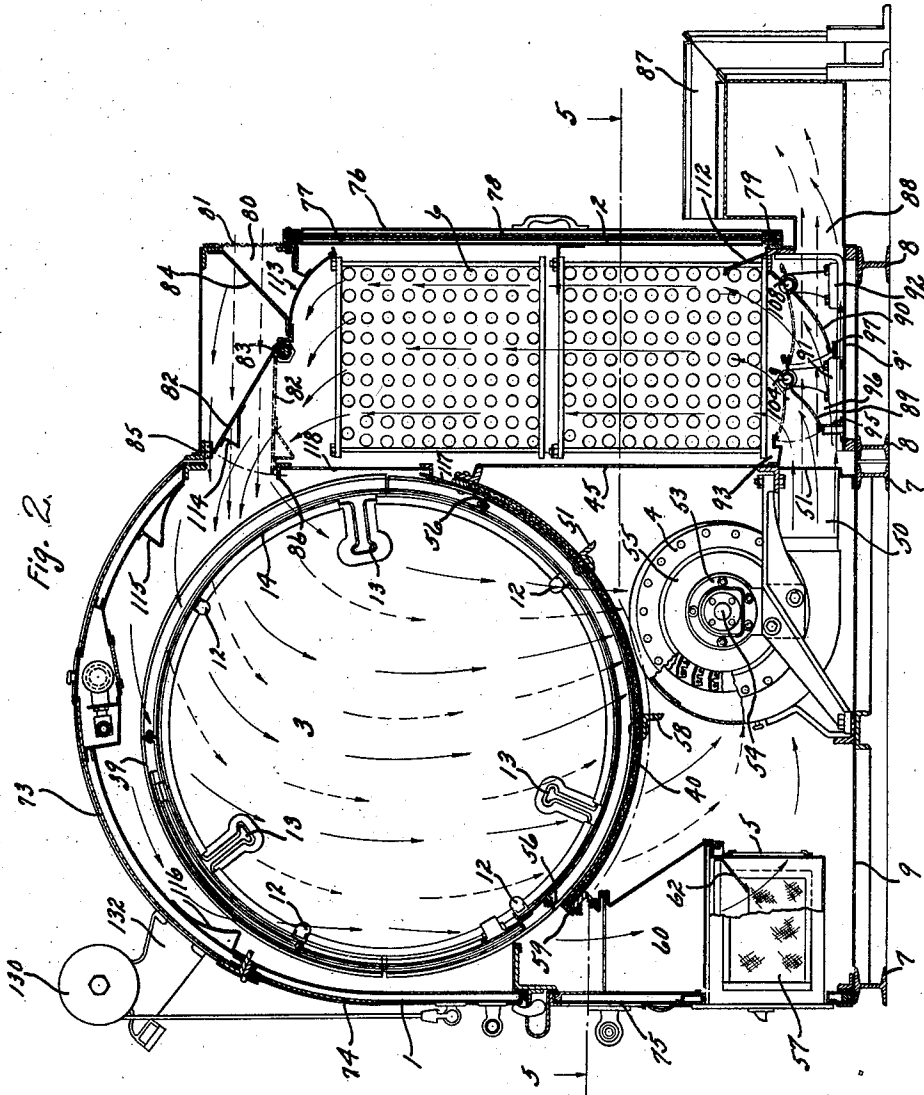

INVENTOR
Charles M. Otis

Brackett, Hyde, Higley & Meyer
ATTORNEYS

UNITED STATES PATENT OFFICE

1,996,253

DRYING TUMBLER

Charles M. Otis, Cincinnati, Ohio, assignor to The American Laundry Machinery Company, Cincinnati, Ohio, a corporation of Ohio

Application July 17, 1931, Serial No. 551,403

5 Claims. (Cl. 34-5)

My invention relates to drying machines of the tumbling type and, particularly, to that type used in laundries in which clothes, wearing apparel or textiles are placed in a revolving cylinder and tumbled through currents of air.

One object of my invention is to provide a drying machine of the above type so constructed and arranged as to produce the largest amount of drying action with the greatest possible efficiency and economy.

Still another object of my invention is to provide a delinting device in the machine which will maintain the circulatory air path in a "free from lint" condition and will positively collect any lint removed from the air path in a readily accessible location.

A further object of my invention is to provide means, in this instance, a wiper or wipers and baffles, that will provide a positive block against the escape of air currents around the outside of the cylinder at all times during rotation thereof and will definitely direct the currents of air into the cylinder.

Other objects and advantageous features of my invention may be seen in the following description and one embodiment thereof may be seen in the accompanying drawings wherein similar characters of reference designate corresponding parts, and wherein:

Fig. 1 is a front elevation of a drying tumbler showing the various control means for the device and the drive for the cylinder at one end of the machine and the drive for the fan at the opposing end thereof. This view also shows the cylinder doors and the delinting apparatus forming a part of my invention.

Fig. 2 is a sectional elevation of the same taken on the line 2-2 of Fig. 1.

Referring to the drawings, I have shown one embodiment of my invention as comprising a drying tumbler embodying a forward section 1 and a rearward section 2, the forward section 1 consisting of a casing covering a drying cylinder 3, one or more fans 4, and an air delinting device 5 and the rearward section 2 consisting of a casing covering a heating unit 6.

The forward and rearward sections 1 and 2 are mounted upon and secured to I-beam bases 7 and 8 respectively and the bottom of the forward and rearward sections consists of a heavy piece of sheet metal 9 supported above the floor of the rooms in which the drying tumbler and heating unit are disposed the height of the I-beam bases 7 and 8 to provide a dead air space between the bottom of the drying tumbler casing and the floor

of the room to form an insulation reducing the loss of heat from the drying tumbler at this point.

The drying cylinder 3 is of the usual construction in this type of machine and mounted in bearings 11 that are preferably of the self-aligning type of tapered roller bearings. Generally, the cylinder is composed of end heads or transmitters having gudgeons secured thereto for support in the bearings 11 and connected together by means of channels 12 and radially extending ribs 13. The main function of the ribs 13, as is well-known in the drying tumbler art, is to effect the raising and subsequent tumbling of the material during the rotation of the cylinder. The frame work making up the end heads or transmitters and the channels and ribs are covered with heavy woven mesh wire 14 providing a strong and durable cylinder and one which will offer the least resistance to the passage of air therethrough.

The cylinder 3 is provided with a plurality of sliding doors 15 of perforated sheet metal formed to the curvature of the cylinder and adapted to slide in guideways 16 formed by circular straps 17, and since a cylinder door that has been in operation over a long period of time becomes thin and worn at the edges which engage the guideways 16, finally becoming so loose and noisy as to require renewal, wear strips 20 are provided which lie in alignment with the door sheet.

As shown in Fig. 1 of the drawings, each cylinder door is provided with spring actuated latches 25 and 26 that are identical in construction.

Axially aligned fans 4 are located approximately midway of the front and rearward side of the drying tumbler, considering the machine as a whole, and are arranged a short distance forwardly of the rear wall 45 that separates the forward and rearward sections 1 and 2 and it will be understood that the number of fans required is proportional to the length of the machine and the proper distribution is dependent on the distance they are spaced apart, the number of fans thereby being preferably variable.

The fans 4 are connected as one integral part to the separate wall or panel 45 by means of ducts 46, 47, 48 and 49 having diverging walls 50 extending from the fan housing openings to a rectangular opening 51 and the diverging walls are interconnected as at 52 to form practically a single fan discharge the entire length of the machine.

In the operation of the fans which are mounted in aligned bearings 53 and on a single shaft 54 and driven by suitable means hereinafter described, air is drawn through openings 55 on

opposing sides of each fan and is then forced out into the heating unit 6 and thence to and through the cylinder 3, the air being then drawn back into the fans 4.

5 The delinting device consists of three main elements, namely, the delinting screen 40, a series of wipers 56, which also act as baffles to prevent circulation of air currents around the outside of the cylinder, disposed around the circumference of the cylinder 3 and a series of removable lint collecting boxes 57 made up of foraminous material so that air currents may pass therethrough. The screen 40 is preferably made up of removable sections and covers substantially the entire bottom area of the cylinder 3, being held in place by angle iron supports 58 and a channel member 59. By removing the channel member 59, the individual sections of the screen 40 may be removed for inspection or renewal. 10 The lint collecting boxes 57 are made up of a stationary portion 60 and a lower removable portion 61, the stationary portion 60 being secured to the inside of the front panel section of the drying tumbler casing so that the front panel forms one wall thereof. 15

20 In the operation of this device, the lint carried by the air currents passing through the cylinder 3 is collected by the screen 40 and scraped into the upper portion 60 of the lint collecting devices by the wipers 56 which may be of any number greater than one so as not to lose the baffle effect and which are provided at their outermost edges with strips of felt. Then, the air being drawn down into the lint collecting device by the fan 4 will carry the lint downwardly into the box where it will be collected by the foraminous material making up the box while the air passes outwardly through the box and into the fans 4. Baffle plates 62 extend downwardly and away from each wall of the lint collecting boxes to provide a trap to prevent upward travel of the lint due to swirling air currents within the box. After the lint collecting boxes have become sufficiently filled, they may 25 be readily removed and emptied. 30

35 A sliding door is supported in guideways at the rear of the apparatus to provide access to the steam coils which make up the heating unit 6, this door being made up of double walls 76 and 77 and provided with heat insulating material 78 between the walls. A strip of felt 79 is preferably secured to the inner wall 77 to provide a sealing means between the portions of the door which overlap the edges of the opening in the casing and to provide a cushioned surface to prevent scratching of the contacting surfaces when the doors are moved. 40

45 The outer casing forming a part of the rearward section 2 is provided above the top edge of the door just described with a rectangular opening 80 extending the full length of the apparatus and covered with a wire mesh screen 81 which serves the purpose of partially straining the fresh air entering the apparatus throughout the entire cycle of operation. A damper 82 that serves to regulate the amount of outside air entering the apparatus extends the full length of the apparatus and is pivotally mounted on a shaft 83 which is supported at intervals by brackets 84. When the damper 82 is in the full line position shown in Fig. 2, only a small amount of air may enter the apparatus through the restricted opening 85. However, when the damper is in the position shown by the dot-dash 50 lines in which it rests on brackets 86, the maxi-

5 mum amount of outside air may enter the apparatus through the substantially rectangular opening 80. Likewise, the damper 82 serves to regulate the amount of heated air entering the cylinder compartment in comparison to the outside air permitted to enter as will be clearly seen in Fig. 2. 5

Below the lowermost edge of the sliding door hereinbefore described another opening is provided through which an amount of air equal to that entering the apparatus through the opening 80 may be exhausted out of the apparatus. For this purpose, a duct 87 is provided and extends outwardly from the exhaust opening 88 of the apparatus. If it is desired, a similar duct may be secured in place over the inlet opening 80 through which the outside air is admitted. 10

15 The amount of air discharged from the apparatus is regulated by dampers 89 and 90 which like the damper 82 extend substantially the full length of the apparatus and fit snugly against the inside panels of the casing. Brackets 91 and 92 that serve to support the dampers 89 and 90 respectively are mounted in the space between the inside panels 93 and the outside panels 94 which make up the end coverings of the rearward section 2 in that space which is a dead air space. This construction provides snug fitting and practically air tight dampers. 20

25 Damper 89 is limited in its downward movement by brackets 95 spaced within the length of the apparatus whereby a narrow rectangular opening is provided between the outermost end of the damper 89 and the bottom 9' of the apparatus through which air may be discharged during the drying period in an amount comparable to the outside air entering the apparatus through the opening 80 during the drying period. The full line positions of the dampers 89 and 90 designate their positions during the drying period wherein the damper 89 splits the draft of air created by the fans 4 and directs a portion of it to the forward section of the heating unit 6 and another portion to the rearward section. 30 The remainder of the heated air passes outwardly to the exhaust duct 87 through an opening 96 which results from the damper 89 being limited in its downward movement by the bracket 95 and the damper 90 being limited in its downward movement by a bracket 97, the amount of air discharged being substantially equal to the outside air entering the apparatus through the opening 80. Thus, during the drying period in which heated air is circulated through the apparatus by the action of the fans 4, a continual discharge of moisture laden air from the apparatus takes place as well as a continual admittance of dry, relatively cool make up air from the outside. 35

40 Baffles 112, 113, 114, 115 and 116 at intervals on the inside of the casing, considering it as a whole, insure that the entire draft of air currents are first directed through the heating unit 6 and then through the cylinder 3 and to evenly distribute the air currents through the apparatus and particularly through the cylinder. Also, the heating unit in the rearward section 2 is isolated from the forward section 1 containing the cylinder 3 by means of the sheet metal panels 45, 117 and 118. It will further be noted that the baffle 114 is carried by the damper 82 and located on its under side. 45

50 The cylinder 3 of the apparatus is driven by means of a motor 134 through a system of pulleys 135, 136 and 137 interconnected by belts 138 from 55 75

which the operator is protected by sheet metal guards 139 and 140. Likewise, the fans 4 are driven by a motor 143 through a system of pulleys.

As shown, the starting and stopping of the motor 134 is preferably controlled by a push button locked on a control box 159 as is the starting and stopping of the motor 143 for operating the fans 4.

What I claim is:

10 1. A drying tumbler, comprising a casing, a rotatable cylinder within said casing, an air moving means therein, a lint collecting means in said casing including a receptacle, and wiper elements carried by said cylinder for moving lint
15 to the entrance of said receptacle, said lint moving means also being arranged to act as baffles to prevent circulation of air around the outside of said cylinder.

20 2. A drying tumbler, comprising a casing, a rotatable cylinder within said casing, means for circulating air through said cylinder, a lint collecting means including a screen positioned adjacent said cylinder, a receptacle, and wiper elements carried by said cylinder for moving lint
25 from said screen and into said receptacle.

3. A drying tumbler, comprising a casing, a rotatable cylinder within said casing, means for circulating air through said cylinder, a lint collecting means including a screen positioned ad-

jacent said cylinder, a receptacle, and wiper elements carried by said cylinder for moving lint from said screen and into said receptacle, said wiper elements being arranged to act as baffles to prevent circulation of air around the outside of said cylinder.

4. A drying tumbler, comprising a casing, a foraminous goods-containing cylinder therein, means for rotating said cylinder, means for circulating air through said cylinder transversely of the axis of rotation thereof, and means for removing lint from the air stream including a screen element substantially curved about said cylinder and through which the drying air passes, and a cooperative wiper element associated with said cylinder to move therewith.

5. A drying tumbler, comprising a casing, a foraminous goods-containing cylinder therein, means for rotating said cylinder, means for circulating air through said cylinder transversely of the axis of rotation thereof, means for removing lint from the air stream including a screen that covers substantially the bottom area of said cylinder and through which the drying air passes, a lint collecting receptacle, and wiper means carried by said cylinder and coacting with said screen to remove lint therefrom and deliver it to said collecting receptacle.

CHARLES M. OTIS.