

(19) World Intellectual Property Organization
International Bureau



(43) International Publication Date
3 May 2001 (03.05.2001)

PCT

(10) International Publication Number
WO 01/30286 A1

(51) International Patent Classification⁷: A61F 9/007,
F04F 1/18

21280 Beach Blvd., #202, Huntington Beach, CA 92648
(US). COHEN, Donald, M.; 17512 Luther, Irvine, CA
92614 (US).

(21) International Application Number: PCT/US00/25709

(74) Agents: SCHIRA, Jeffrey, S. et al.; R & D Legal Dept.,
Q-148, Alcon Laboratories, Inc., 6201 South Freeway, Fort
Worth, TX 76134-2099 (US).

(22) International Filing Date:
18 September 2000 (18.09.2000)

(25) Filing Language: English

(81) Designated States (*national*): AU, BR, CA, JP, MX.

(26) Publication Language: English

(84) Designated States (*regional*): European patent (AT, BE,
CH, CY, DE, DK, ES, FI, FR, GB, GR, IE, IT, LU, MC,
NL, PT, SE).

(30) Priority Data:
09/428,744 28 October 1999 (28.10.1999) US

Published:
— With international search report.

(71) Applicant: ALCON LABORATORIES, INC. [US/US];
6201 South Freeway, Fort Worth, TX 76134-2099 (US).

For two-letter codes and other abbreviations, refer to the "Guid-
ance Notes on Codes and Abbreviations" appearing at the begin-
ning of each regular issue of the PCT Gazette.

(72) Inventors: SUSSMAN, Glenn; 21942 Raintree Lane,
Lake Forest, CA 92630 (US). PADGET, Martin, J.;

(54) Title: TIP FOR A LIQUEFRACTURE HANDPIECE

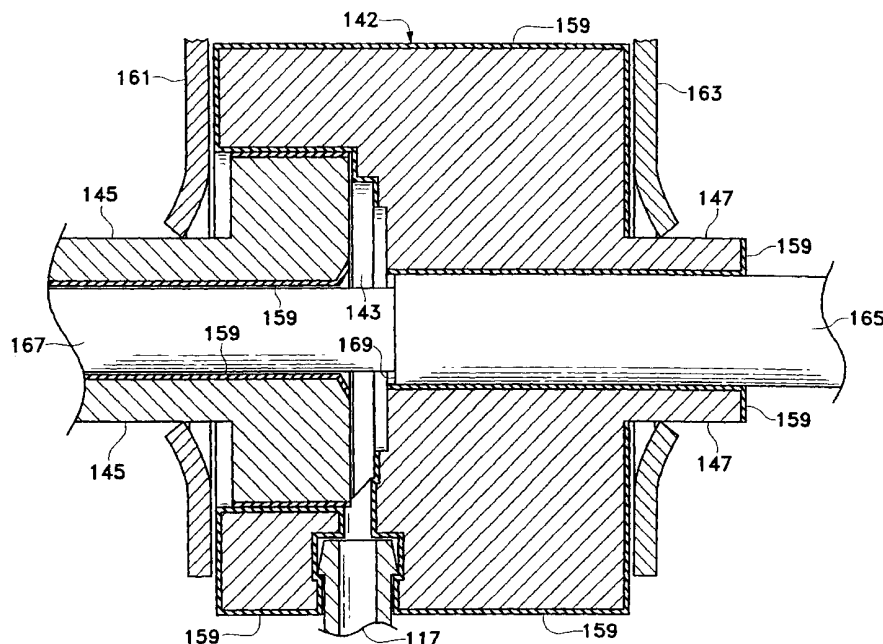

(57) Abstract: A surgical handpiece having two coaxial tubes or channels mounted within a body. The first tube is used for aspiration and is smaller in diameter than the second tube so as to create an annular passage between the first and second tube. The annular passage communicates with a pumping chamber formed between two electrodes. The pumping chamber works by boiling a small volume of the surgical fluid. As the fluid boils, it expands rapidly, thereby propelling the liquid downstream of the pumping chamber out of the annular passage. The electrodes are insulated from each other.



WO 01/30286 A1

TIP FOR A LIQUEFRACTURE HANDPIECE

Background of the Invention

5 This invention relates generally to the field of cataract surgery and more particularly to a handpiece for practicing the liquefracture technique of cataract removal.

The human eye in its simplest terms functions to provide vision by transmitting light through a clear outer portion called the cornea, and focusing the image by way of the lens onto the retina. The quality of the focused image depends on many factors including
10 the size and shape of the eye, and the transparency of the cornea and lens.

When age or disease causes the lens to become less transparent, vision deteriorates because of the diminished light which can be transmitted to the retina. This deficiency in the lens of the eye is medically known as a cataract. An accepted treatment for this condition is surgical removal of the lens and replacement of the lens function by an
15 artificial intraocular lens (IOL).

In the United States, the majority of cataractous lenses are removed by a surgical technique called phacoemulsification. During this procedure, a thin phacoemulsification cutting tip is inserted into the diseased lens and vibrated ultrasonically. The vibrating cutting tip liquifies or emulsifies the lens so that the lens may be aspirated out of the eye.
20 The diseased lens, once removed, is replaced by an artificial lens.

A typical ultrasonic surgical device suitable for ophthalmic procedures consists of an ultrasonically driven handpiece, an attached cutting tip, and irrigating sleeve and an electronic control console. The handpiece assembly is attached to the control console by an electric cable and flexible tubings. Through the electric cable, the console varies the
25 power level transmitted by the handpiece to the attached cutting tip and the flexible tubings supply irrigation fluid to and draw aspiration fluid from the eye through the handpiece assembly.

The operative part of the handpiece is a centrally located, hollow resonating bar or horn directly attached to a set of piezoelectric crystals. The crystals supply the required
30 ultrasonic vibration needed to drive both the horn and the attached cutting tip during phacoemulsification and are controlled by the console. The crystal/horn assembly is suspended within the hollow body or shell of the handpiece by flexible mountings. The handpiece body terminates in a reduced diameter portion or nosecone at the body's distal

end. The nosecone is externally threaded to accept the irrigation sleeve. Likewise, the horn bore is internally threaded at its distal end to receive the external threads of the cutting tip. The irrigation sleeve also has an internally threaded bore that is screwed onto the external threads of the nosecone. The cutting tip is adjusted so that the tip projects only a predetermined amount past the open end of the irrigating sleeve. Ultrasonic handpieces and cutting tips are more fully described in U.S. Pat. Nos. 3,589,363; 4,223,676; 4,246,902; 4,493,694; 4,515,583; 4,589,415; 4,609,368; 4,869,715; 4,922,902; 4,989,583; 5,154,694 and 5,359,996, the entire contents of which are incorporated herein by reference.

In use, the ends of the cutting tip and irrigating sleeve are inserted into a small incision of predetermined width in the cornea, sclera, or other location. The cutting tip is ultrasonically vibrated along its longitudinal axis within the irrigating sleeve by the crystal-driven ultrasonic horn, thereby emulsifying the selected tissue in situ. The hollow bore of the cutting tip communicates with the bore in the horn that in turn communicates with the aspiration line from the handpiece to the console. A reduced pressure or vacuum source in the console draws or aspirates the emulsified tissue from the eye through the open end of the cutting tip, the cutting tip and horn bores and the aspiration line and into a collection device. The aspiration of emulsified tissue is aided by a saline flushing solution or irrigant that is injected into the surgical site through the small annular gap between the inside surface of the irrigating sleeve and the cutting tip.

Recently, a new cataract removal technique has been developed that involves the injection of hot (approximately 45°C to 105°C) water or saline to liquefy or gellate the hard lens nucleus, thereby making it possible to aspirate the liquefied lens from the eye. Aspiration is conducted concurrently with the injection of the heated solution and the injection of a relatively cool solution, thereby quickly cooling and removing the heated solution. This technique is more fully described in U.S. Patent No. 5,616,120 (Andrew, et al.), the entire content of which is incorporated herein by reference. The apparatus disclosed in the publication, however, heats the solution separately from the surgical handpiece. Temperature control of the heated solution can be difficult because the fluid tubings feeding the handpiece typically are up to two meters long, and the heated solution can cool considerably as it travels down the length of the tubing.

U.S. Patent No. 5,885,243 (Capetan, et al.) discloses a handpiece having a separate pumping mechanism and resistive heating element. Such a structure adds unnecessary complexity to the handpiece.

Therefore, a need continues to exist for a simple surgical handpiece that can heat internally the solution used to perform the liquefracture technique.

Brief Summary of the Invention

The present invention improves upon the prior art by providing a surgical handpiece having two coaxially mounted tubes or channels mounted to a body. The first tube is used for aspiration and is smaller in diameter than the second tube so as to create an annular passage between the first and second tube. The annular gap communicates with a pumping chamber formed between two electrodes. The pumping chamber works by boiling a small volume of the surgical fluid. As the fluid boils, it expands rapidly, thereby propelling the liquid downstream of the pumping chamber out of the annular gap. The electrodes are insulated from each other.

Accordingly, one objective of the present invention is to provide a surgical handpiece having at least two coaxial tubes.

Another objective of the present invention is to provide a handpiece having a pumping chamber.

Another objective of the present invention is to provide a surgical handpiece having a device for delivering the surgical fluid through the handpiece in pulses.

Still another objective of the present invention is to provide a handpiece having a pumping chamber formed by two electrodes.

Yet another objective of the present invention is to provide a handpiece having two electrodes wherein the electrodes are insulated.

These and other advantages and objectives of the present invention will become apparent from the detailed description and claims that follow.

Brief Description of the Drawings

FIG. 1 is a front, upper left perspective view of a first embodiment of the handpiece of the present invention.

FIG. 2 is a rear, upper right perspective view of a first embodiment of the handpiece of the present invention.

FIG. 3 is a cross-sectional view of a first embodiment of the handpiece of the present invention taken along a plane passing through the irrigation channel.

FIG. 4 is a cross-sectional view of a first embodiment of the handpiece of the present invention taken along a plane passing through the aspiration channel.

FIG. 5 is an enlarged partial cross-sectional view of a first embodiment of the handpiece of the present invention taken at circle 5 in FIG. 4.

FIG. 6 is an enlarged partial cross-sectional view of a first embodiment of the handpiece of the present invention taken at circle 6 in FIG. 3.

FIG. 7 is an enlarged cross-sectional view of a first embodiment of the handpiece of the present invention taken at circle 7 in FIGS. 3 and 4.

FIG. 8 is a partial cross-sectional view of a second embodiment of the handpiece of the present invention.

FIG. 9 is an enlarged partial cross-sectional view of the second embodiment of the handpiece of the present invention taken at circle 9 in FIG. 8.

FIG. 10 is an enlarged partial cross-sectional view of the pumping chamber used in the second embodiment of the handpiece of the present invention taken at circle 10 in FIG. 9.

FIG. 11 is a partial cross-sectional view of a third embodiment of the handpiece of the present invention.

FIG. 12 is an enlarged partial cross-sectional view of the distal end of the third embodiment of the handpiece of the present invention taken at circle 12 in FIG. 11.

FIG. 13 is an enlarged partial cross-sectional view of the pumping chamber used in the third embodiment of the handpiece of the present invention shown in FIGS. 11 and 12.

FIG. 14 is a block diagram of a control system that can be used with the handpiece of the present invention.

Detailed Description of the Invention

Handpiece 10 of the present invention generally includes handpiece body 12 and operative tip 16. Body 12 generally includes external irrigation tube 18 and aspiration fitting 20. Body 12 is similar in construction to well-known in the art phacoemulsification handpieces and may be made from plastic, titanium or stainless steel. As best seen in FIG. 6, operative tip 16 includes tip/cap sleeve 26, needle 28 and tube 30. Sleeve 26 may be any suitable commercially available phacoemulsification tip/cap sleeve or sleeve 26 may be incorporated into other tubes as a multi-lumen tube. Needle 28 may be any commercially available hollow phacoemulsification cutting tip, such as the TURBOSONICS tip available from Alcon Laboratories, Inc., Fort Worth, Texas. Tube 30 may be any suitably sized tube to fit within needle 28, for example 29 gauge hypodermic needle tubing.

As best seen in FIG. 5, tube 30 is free on the distal end and connected to pumping chamber 42 on the proximal end. Tube 30 and pumping chamber 42 may be sealed fluid tight by any suitable means having a relatively high melting point, such as a silicone gasket, glass frit or silver solder. Fitting 44 holds tube 30 within bore 48 of aspiration horn 46. Bore 48 communicates with fitting 20, which is journaled into horn 46 and sealed with O-ring seal 50 to form an aspiration pathway through horn 46 and out fitting 20. Horn 46 is held within body 12 by O-ring seal 56 to form irrigation tube 52 which communicates with irrigation tube 18 at port 54.

As best seen in FIG. 7, in a first embodiment of the present invention, pumping chamber 42 contains a relatively large pumping reservoir 43 that is sealed on both ends by electrodes 45 and 47. Electrical power is supplied to electrodes 45 and 47 by insulated wires, not shown. In use, surgical fluid (*e.g.* saline irrigating solution) enters reservoir 43 through port 55, tube 34 and check valve 53, check valves 53 being well-known in the art. Electrical current (preferably Radio Frequency Alternating Current or RFAC) is delivered to and across electrodes 45 and 47 because of the conductive nature of the surgical fluid. As the current flows through the surgical fluid, the surgical fluid boils. As the surgical fluid boils, it expands rapidly out of pumping chamber 42 through port 57 and into tube 30 (check valve 53 prevents the expanding fluid from entering tube 34). The expanding gas bubble pushes the surgical fluid in tube 30 downstream of pumping chamber 42

forward. Subsequent pulses of electrical current form sequential gas bubbles that move surgical fluid down tube 30. The size and pressure of the fluid pulse obtained by pumping chamber 42 can be varied by varying the length, timing and/or power of the electrical pulse sent to electrodes 45 and 47 and by varying the dimensions of reservoir 43. In addition, the surgical fluid may be preheated prior to entering pumping chamber 42. Preheating the surgical fluid will decrease the power required by pumping chamber 42 and/or increase the speed at which pressure pulses can be generated.

As best seen in FIGS. 8-10, in a second embodiment of the present invention, handpiece 110 generally includes body 112, having power supply cable 113, irrigation/aspiration lines 115, pumping chamber supply line 117. Distal end 111 of handpiece 110 contains pumping chamber 142 having a reservoir 143 formed between electrodes 145 and 147. Electrodes 145 and 147 are preferably made from aluminum, titanium, carbon or other similarly conductive materials and are electrically insulated from each other and body 112 by anodized layer 159 formed on electrodes 145 and 147. Anodized layer 159 is less conductive than untreated aluminum and thus, acts as an electrical insulator. Electrodes 145 and 147 and electrical terminals 161 and 163 are not anodized and thus, are electrically conductive. Layer 159 may be formed by any suitable anodization technique, well-known in the art, and electrodes 145 and 147 and electrical terminals 161 and 163 may be masked during anodization or machined after anodization to expose bare aluminum. Electrical power is supplied to electrodes 145 and 147 through terminals 161 and 163 and wires 149 and 151, respectively. Fluid is supplied to reservoir 143 through supply line 117 and check valve 153. Extending distally from pumping chamber 142 is outer tube 165 that coaxially surrounds aspiration tube 167. Tubes 165 and 167 may be of similar construction as tube 30. Tube 167 is of slightly smaller diameter than tube 165, thereby forming an annular passage or gap 169 between tube 165 and tube 167. Annular gap 169 fluidly communicates with reservoir 143.

In use, surgical fluid enters reservoir 143 through supply line 117 and check valve 153. Electrical current is delivered to and across electrodes 145 and 147 because of the conductive nature of the surgical fluid. As the current flows through the surgical fluid, the surgical fluid boils. As the surgical fluid boils, it expands rapidly out of pumping chamber 142 through annular gap 169. The expanding gas bubble pushes forward the surgical fluid in annular gap 169 downstream of pumping chamber 142. Subsequent pulses of electrical

current form sequential gas bubbles that move or propel the surgical fluid down annular gap 169.

One skilled in the art will recognize that the numbering in FIGS. 8-10 is identical to the numbering in FIGS. 1-7 except for the addition of "100" in FIGS. 8-10.

5 As best seen in FIGS. 11-13, in a third embodiment of the present invention, handpiece 210 generally includes body 212, having power supply cable 213, irrigation/aspiration lines 215, pumping chamber supply line 217. Distal end 211 of handpiece 210 contains pumping chamber 242 having a reservoir 243 formed between electrodes 245 and 247. Electrodes 245 and 247 are preferably made from aluminum and electrically insulated from each other and body 212 by anodized layer 259 formed on
10 electrodes 245 and 247. Anodized layer 259 is less conductive than untreated aluminum and thus, acts as an electrical insulator. Electrodes 245 and 247 and electrical terminals 261 and 263 are not anodized and thus, are electrically conductive. Layer 259 may be formed by any suitable anodization technique, well-known in the art, and electrodes 245
15 and 247 and electrical terminals 261 and 263 may be masked during anodization or machined after anodization to expose bare aluminum. Electrical power is supplied to electrodes 245 and 247 through terminals 261 and 263 and wires 249 and 251, respectively. Fluid is supplied to reservoir 243 through supply line 217 and check valve 253. Extending distally from pumping chamber 242 is outer tube 265 that coaxially
20 surrounds aspiration tube 267. Tubes 265 and 267 may be of similar construction as tube 30. Tube 267 is of slightly smaller diameter than tube 265, thereby forming an annular passage or gap 269 between tube 265 and tube 267. Annular gap 269 fluidly communicates with reservoir 243.

In use, surgical fluid enters reservoir 243 through supply line 217 and check valve
25 253. Electrical current is delivered to and across electrodes 245 and 247 because of the conductive nature of the surgical fluid. As the current flows through the surgical fluid, the surgical fluid boils. The current flow progresses from the smaller electrode gap section to the larger electrode gap section, i.e., from the region of lowest electrical resistance to the region of higher electrical resistance. The boiling wavefront also progresses from the
30 smaller to the larger end of electrode 247. As the surgical fluid boils, it expands rapidly out of pumping chamber 242 through annular gap 269. The expanding gas bubble pushes forward the surgical fluid in annular gap 269 downstream of pumping chamber 242.

Subsequent pulses of electrical current form sequential gas bubbles that move or propel the surgical fluid down annular gap 269.

One skilled in the art will recognize that the numbering in FIGS. 11-13 is identical to the numbering in FIGS. 1-7 except for the addition of "200" in FIGS. 11-13.

5 While several embodiments of the handpiece of the present invention are disclosed, any handpiece producing adequate pressure pulse force, temperature, rise time and frequency may also be used. For example, any handpiece producing a pressure pulse force of between 0.02 grams and 20.0 grams, with a rise time of between 1 gram/sec. and 20,000 grams/sec and a frequency of between 1 Hz and 200 Hz may be used, with
10 between 10 Hz and 100 Hz being most preferred. The pressure pulse force and frequency will vary with the hardness of the material being removed. For example, the inventors have found that a lower frequency with a higher pulse force is most efficient at debulking and removing the relatively hard nuclear material, with a higher frequency and lower pulse force being useful in removing softer epinuclear and cortical material. Infusion pressure,
15 aspiration flow rate and vacuum limit are similar to current phacoemulsification techniques.

As seen in FIG. 10, one embodiment of control system 300 for use in operating handpiece 310 includes control module 347, power gain RF amplifier 312 and function generator 314. Power is supplied to RF amplifier 312 by DC power supply 316, which
20 preferably is an isolated DC power supply operating at several hundred volts, but typically ± 200 volts. Control module 347 may be any suitable microprocessor, micro controller, computer or digital logic controller and may receive input from operator input device 318. Function generator 314 provides the electric wave form in kilohertz to amplifier 312 and typically operates at around 450 KHz or above to help minimize corrosion.

25 In use, control module 347 receives input from surgical console 320. Console 320 may be any commercially available surgical control console such as the LEGACY® SERIES TWENTY THOUSAND® surgical system available from Alcon Laboratories, Inc., Fort Worth, Texas. Console 320 is connected to handpiece 310 through irrigation line 322 and aspiration line 324, and the flow through lines 322 and 324 is controlled by
30 the user via footswitch 326. Irrigation and aspiration flow rate information in handpiece 310 is provided to control module 347 by console 320 via interface 328, which may be connected to the ultrasound handpiece control port on console 320 or to any other output

port. Control module 347 uses footswitch 326 information provided by console 320 and operator input from input device 318 to generate two control signals 330 and 332. Signal 332 is used to operate pinch valve 334, which controls the surgical fluid flowing from fluid source 336 to handpiece 310. Fluid from fluid source 336 is heated in the manner described herein. Signal 330 is used to control function generator 314. Based on signal 330, function generator 314 provides a wave form at the operator selected frequency and amplitude determined by the position of footswitch 326 to RF amplifier 312 which is amplified to advance the powered wave form output to handpiece 310 to create heated, pressurized pulses of surgical fluid.

Any of a number of methods can be employed to limit the amount of heat introduced into the eye. For example, the pulse train duty cycle of the heated solution can be varied as a function of the pulse frequency so that the total amount of heated solution introduced into the eye does not vary with the pulse frequency. Alternatively, the aspiration flow rate can be varied as a function of pulse frequency so that as pulse frequency increases aspiration flow rate increases proportionally.

This description is given for purposes of illustration and explanation. It will be apparent to those skilled in the relevant art that changes and modifications may be made to the invention described above without departing from its scope or spirit. For example, it will be recognized by those skilled in the art that the present invention may be combined with ultrasonic and/or rotating cutting tips to enhance performance.

We claim:

- 1 1. A liquefracture handpiece, comprising:
 - 2 a) a body;
 - 3 b) an aspiration tube coaxially mounted within an outer tube so as to form an
4 annular gap between the aspiration tube and the outer tube; and
 - 5 c) a pumping chamber mounted within the body, the pumping chamber having
6 a pair of electrodes that allow electrical current to flow across the electrodes when
7 a surgical fluid is contained within the pumping chamber, the pumping chamber
8 being in fluid communication with the annular gap.

- 1 2. The handpiece of claim 1 wherein the electrodes contain an anodized layer.

- 1 3. The handpiece of claim 1 wherein the electrical current flowing across the
2 electrodes is capable of boiling the surgical fluid.

- 1 4. The handpiece of claim 3 wherein the boiling surgical fluid is propelled
2 down the annular gap.

- 1 5. The handpiece of claim 1 wherein the handpiece produces a pressure pulse
2 force of between 0.02 grams and 20.0 grams, with a rise time of between 1 gram/second
3 and 20,000 grams/second.

- 1 6. A liquefracture handpiece, comprising:
 - 2 a) a body;
 - 3 b) an aspiration tube coaxially mounted within an outer tube so as to form an
4 annular gap between the aspiration tube and the outer tube; and
 - 5 c) a pumping chamber mounted within the body, the pumping chamber formed
6 by a pair of electrodes that allow electrical current to flow across the electrodes
7 when a surgical fluid is contained within the pumping chamber, the pumping
8 chamber being in fluid communication with the annular gap.

1 7. The handpiece of claim 6 wherein the electrodes contain an anodized layer.

1 8. The handpiece of claim 6 wherein the electrical current flowing across the
2 electrodes is capable of boiling the surgical fluid.

1 9. The handpiece of claim 8 wherein the boiling surgical fluid is propelled
2 down the annular gap.

1 10. The handpiece of claim 6 wherein the handpiece produces a pressure pulse
2 force of between 0.02 grams and 20.0 grams, with a rise time of between 1 gram/second
3 and 20,000 grams/second.

1 11. A liquefracture handpiece, comprising:

2 a) a body;

3 b) an aspiration tube coaxially mounted within an outer tube so as to form an
4 annular gap between the aspiration tube and the outer tube; and

5 c) a pumping chamber mounted within the body, the pumping chamber having
6 a pair of electrodes that allow electrical current to flow across the electrodes when
7 a surgical fluid is contained within the pumping chamber, the pumping chamber
8 being in fluid communication with the annular gap and produces a pressure pulse
9 force of between 0.02 grams and 20.0 grams, with a rise time of between 1
10 gram/second and 20,000 grams/second.

1 12. The handpiece of claim 11 wherein the electrodes contain an anodized layer.

1 13. The handpiece of claim 11 wherein the electrical current flowing across the
2 electrodes is capable of boiling the surgical fluid.

1 14. The handpiece of claim 13 wherein the boiling surgical fluid is propelled
2 down the annular gap.

1 15. A method of operating a liquefracture handpiece, the handpiece having a
2 body and a pumping chamber contained within the body, the method comprising the steps
3 of:

- 4 a) operating the pumping chamber at a pulse frequency;
- 5 b) varying the pulse frequency; and
- 6 c) varying an aspiration flow rate as a function of the pulse frequency.

1 16. The method of claim 15 wherein the handpiece produces a pressure pulse
2 force of between 0.02 grams and 20.0 grams, with a rise time of between 1 gram/second
3 and 20,000 grams/second.

1 17. A method of operating a liquefracture handpiece, the handpiece having a
2 body and a pumping chamber contained within the body, the method comprising the steps
3 of:

- 4 a) operating the pumping chamber at a pulse frequency and with a pulse train
5 duty cycle;
- 6 b) varying the pulse frequency; and
- 7 c) varying the pulse train duty cycle as a function of the pulse frequency.

1 18. The handpiece of claim 17 wherein the handpiece produces a pressure pulse
2 force of between 0.02 grams and 20.0 grams, with a rise time of between 1 gram/second
3 and 20,000 grams/second.

1 19. A method of operating a liquefracture handpiece, the handpiece having a
2 body and a pumping chamber contained within the body, the method comprising the steps
3 of:

- 4 a) operating the pumping chamber at a predetermined operating parameter so
5 as to produce a pulse stream; and
- 6 b) varying the operating parameter so as to vary the coherence length of the
7 pulse stream.

1 20. The method of claim 19 wherein the handpiece produces a pressure pulse
2 force of between 0.02 grams and 20.0 grams, with a rise time of between 1 gram/second
3 and 20,000 grams/second.

1 21. The method of claim 19 wherein the parameter is flow development.

1 22. The method of claim 19 wherein the parameter is pressure.

1 23. The method of claim 19 wherein the parameter is temperature.

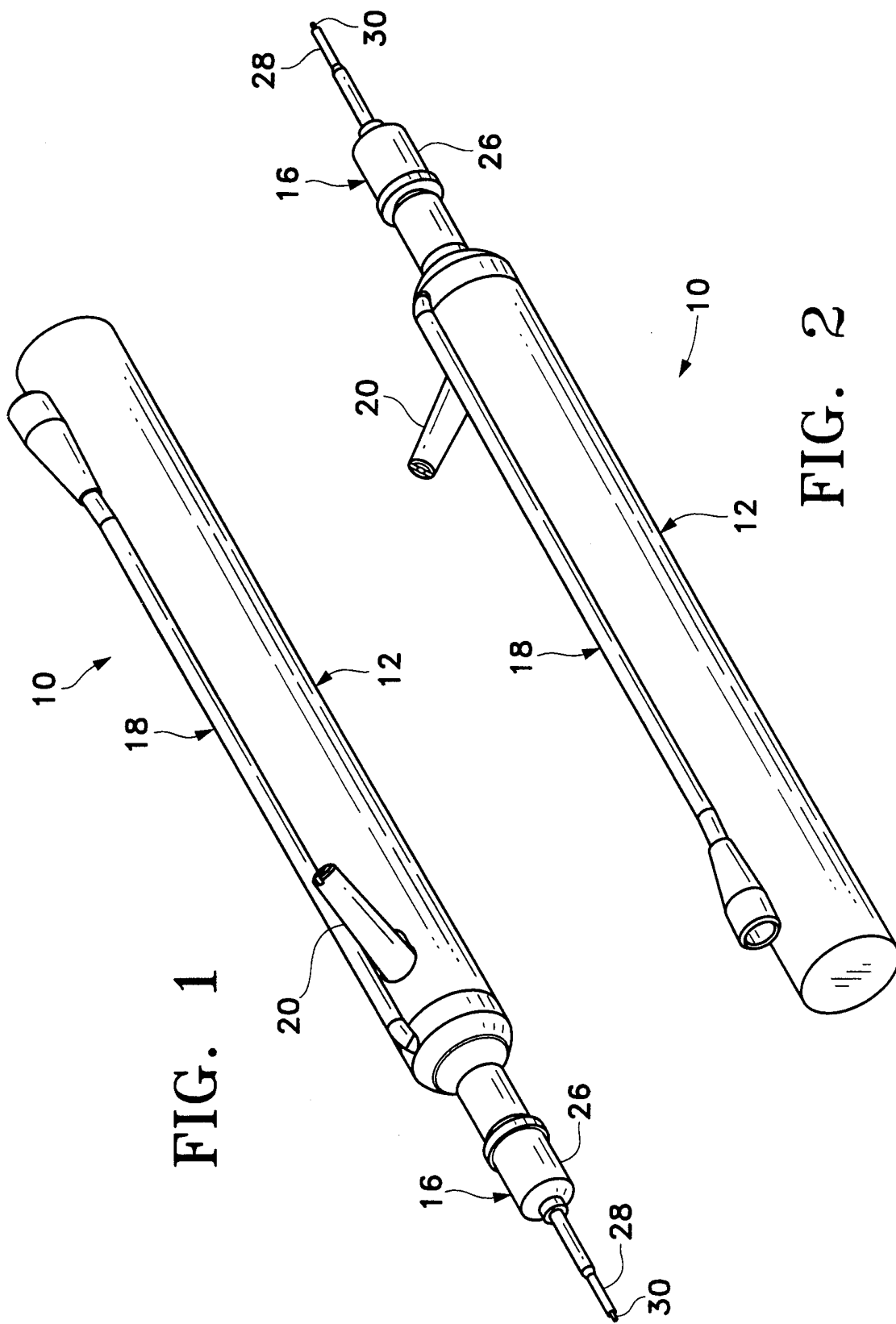

FIG. 1

FIG. 2

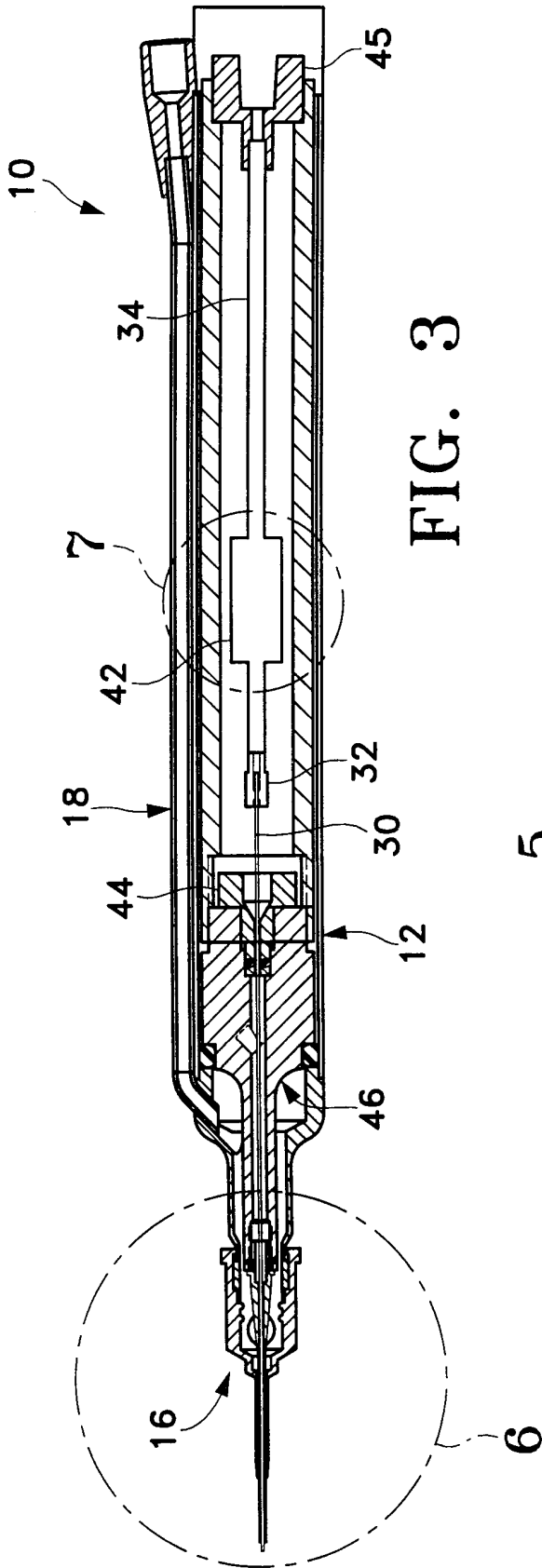

FIG. 3

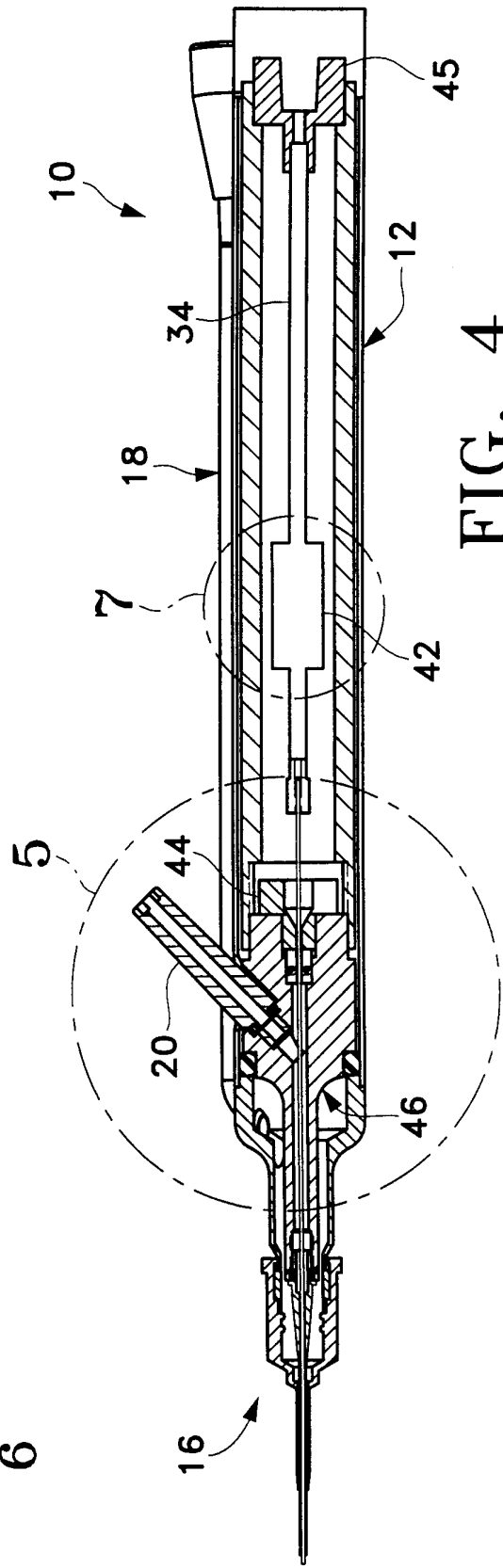

FIG. 4

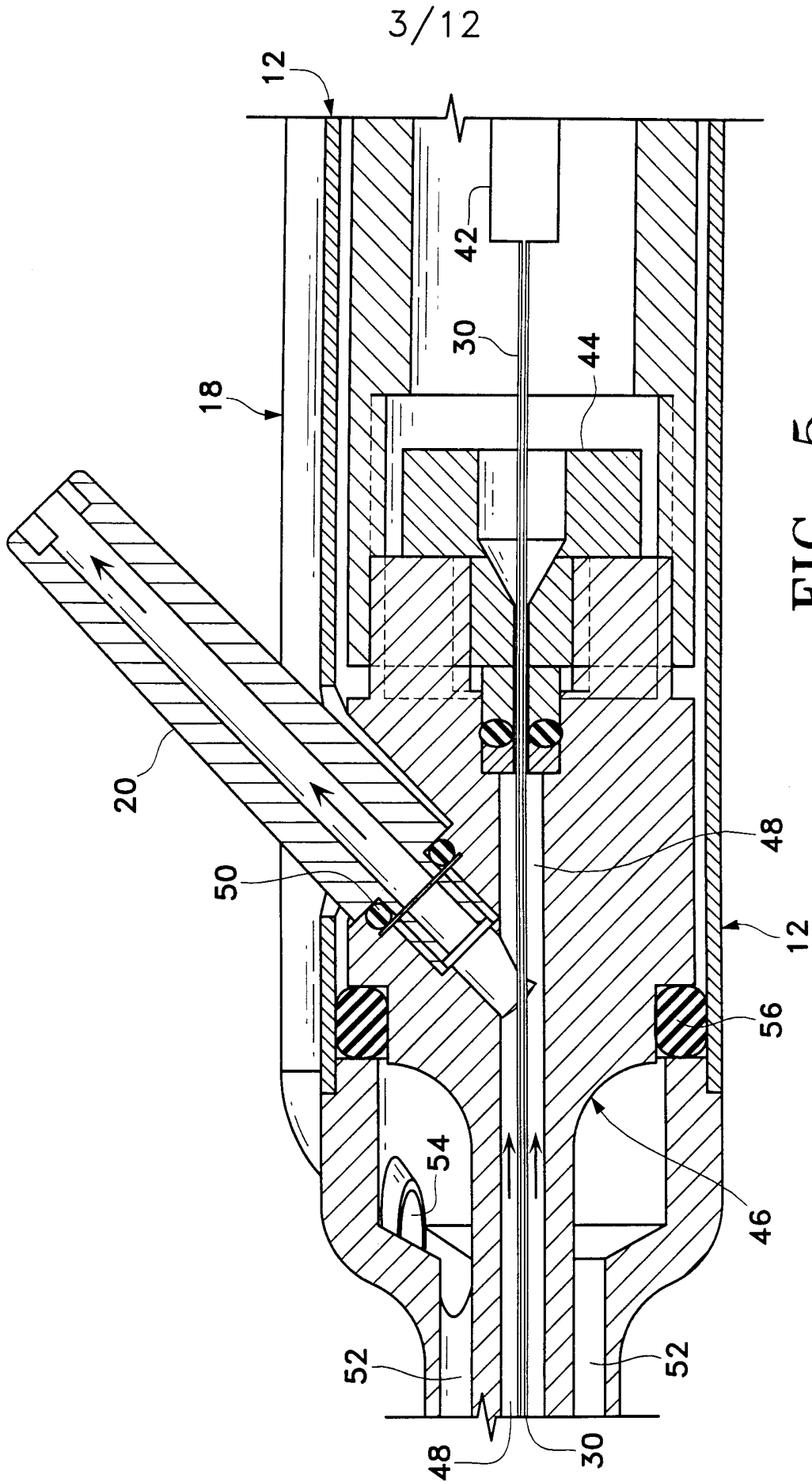

FIG. 5

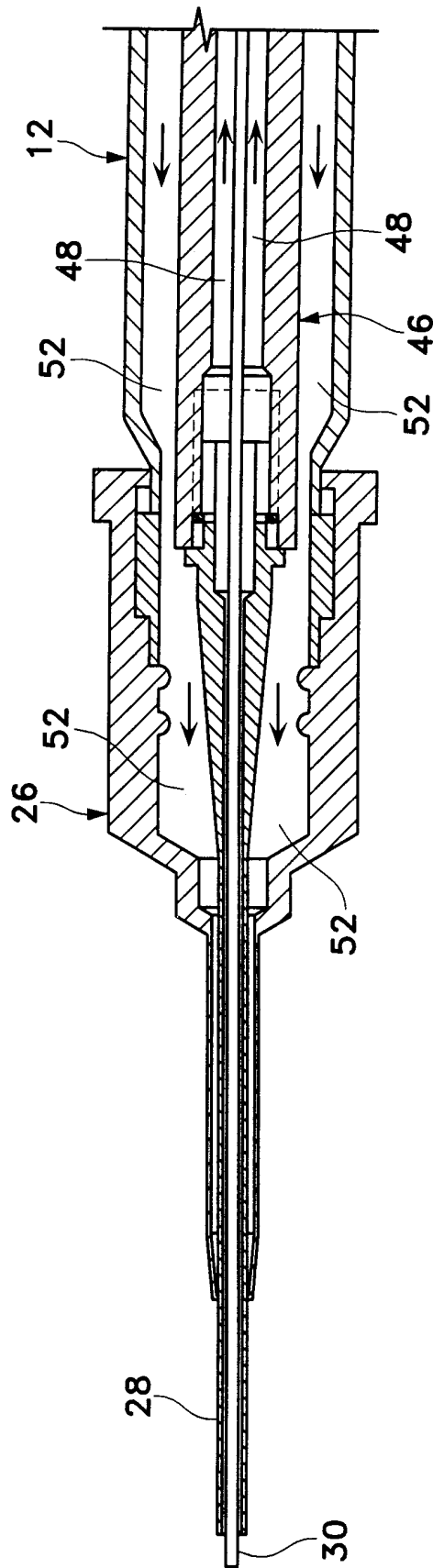

FIG. 6

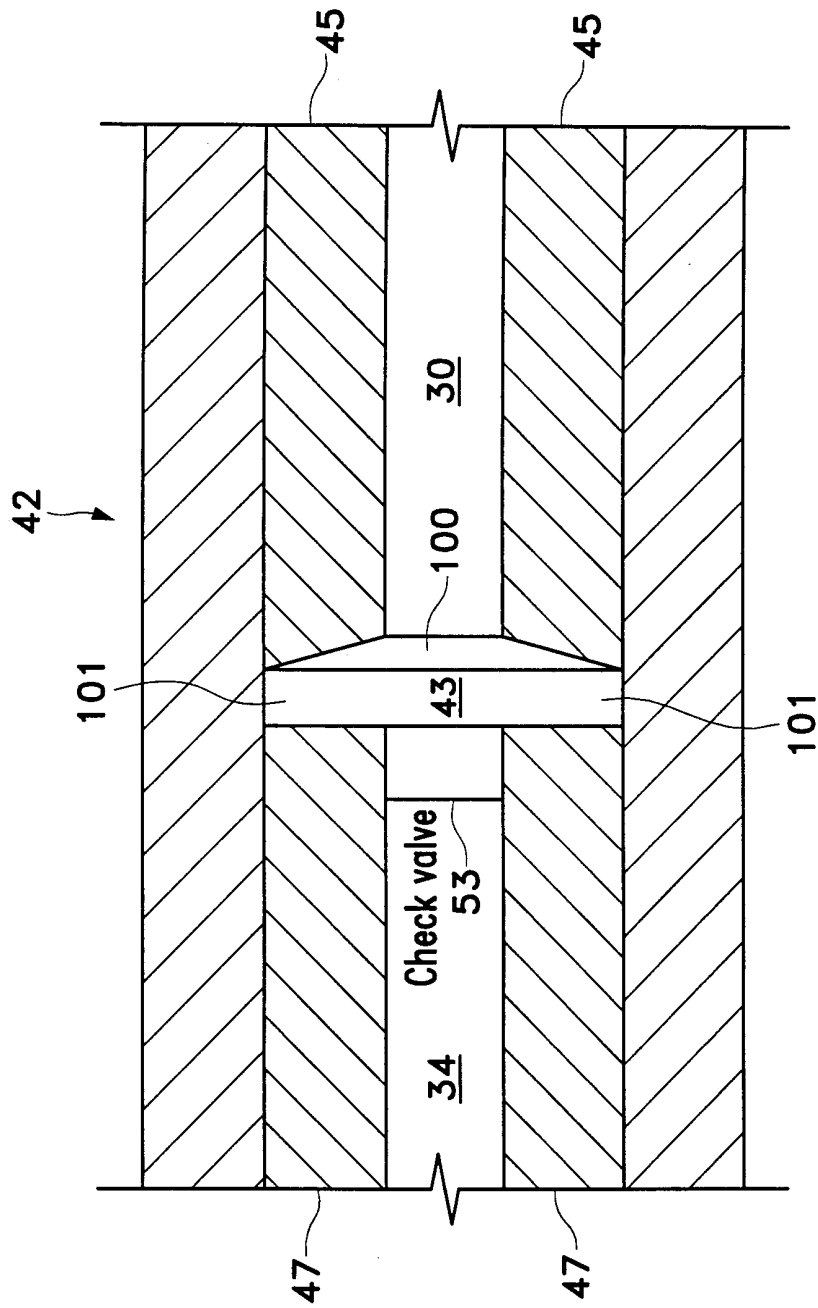

FIG. 7

6/12

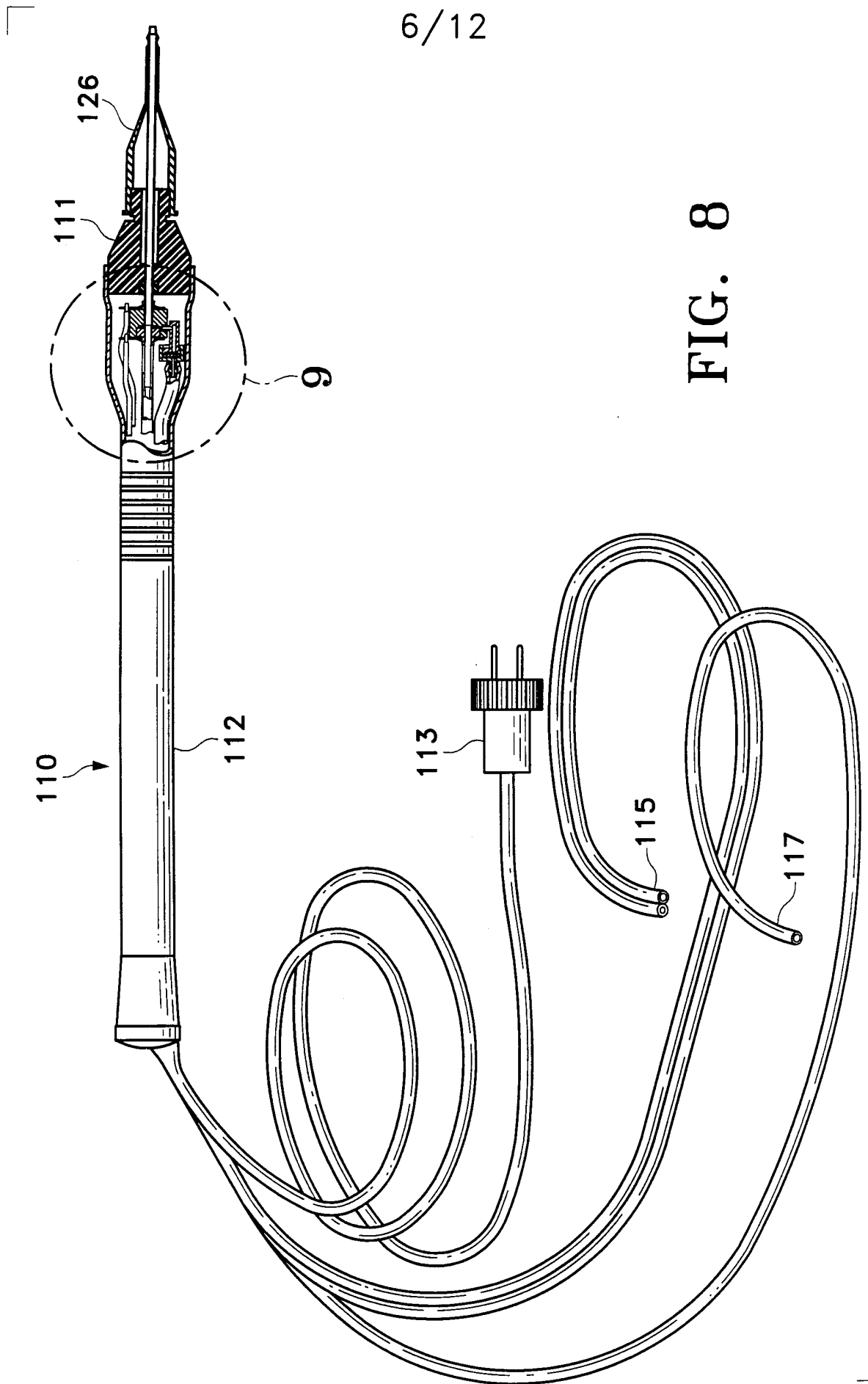

FIG. 8

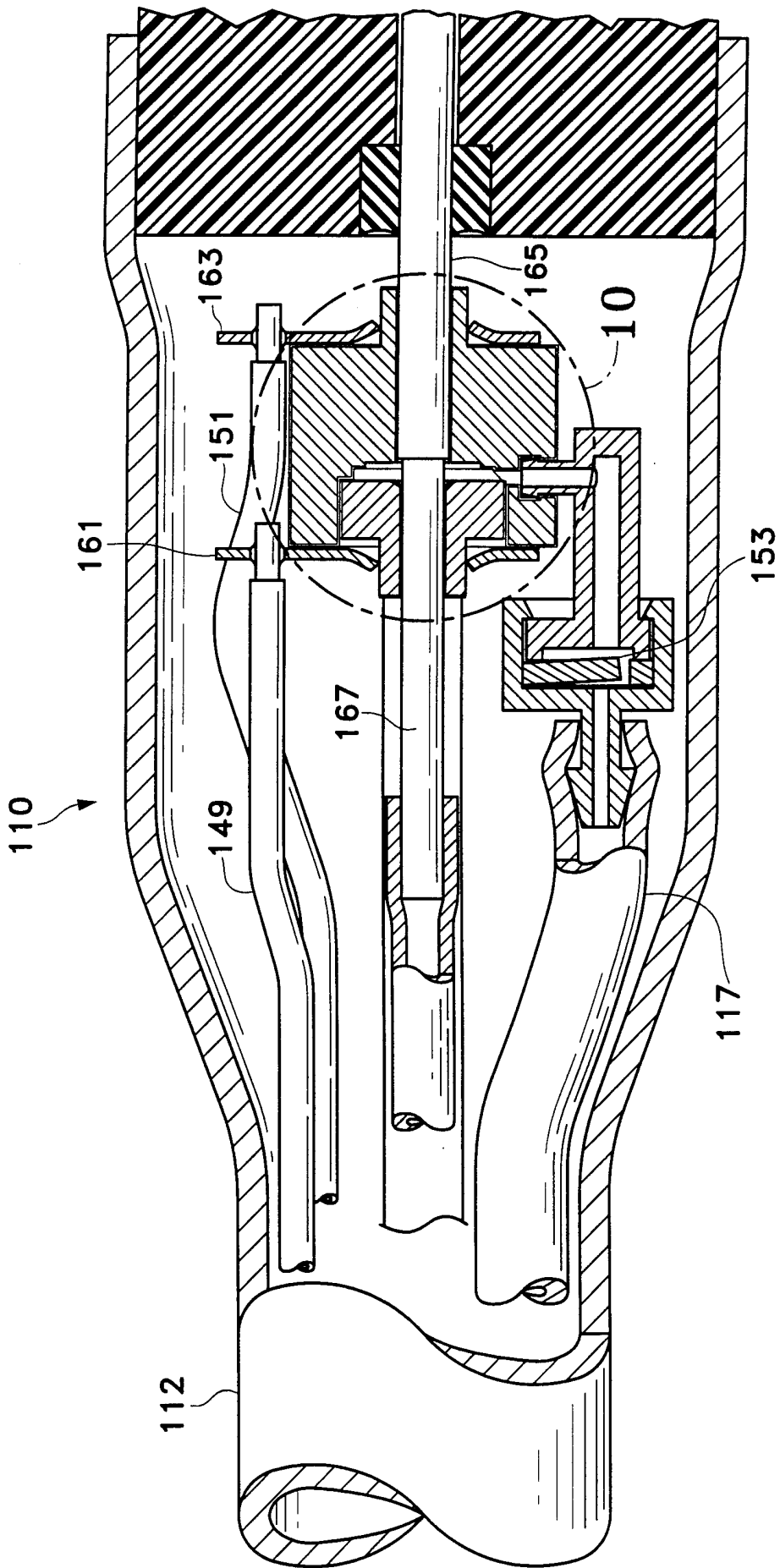

FIG. 9

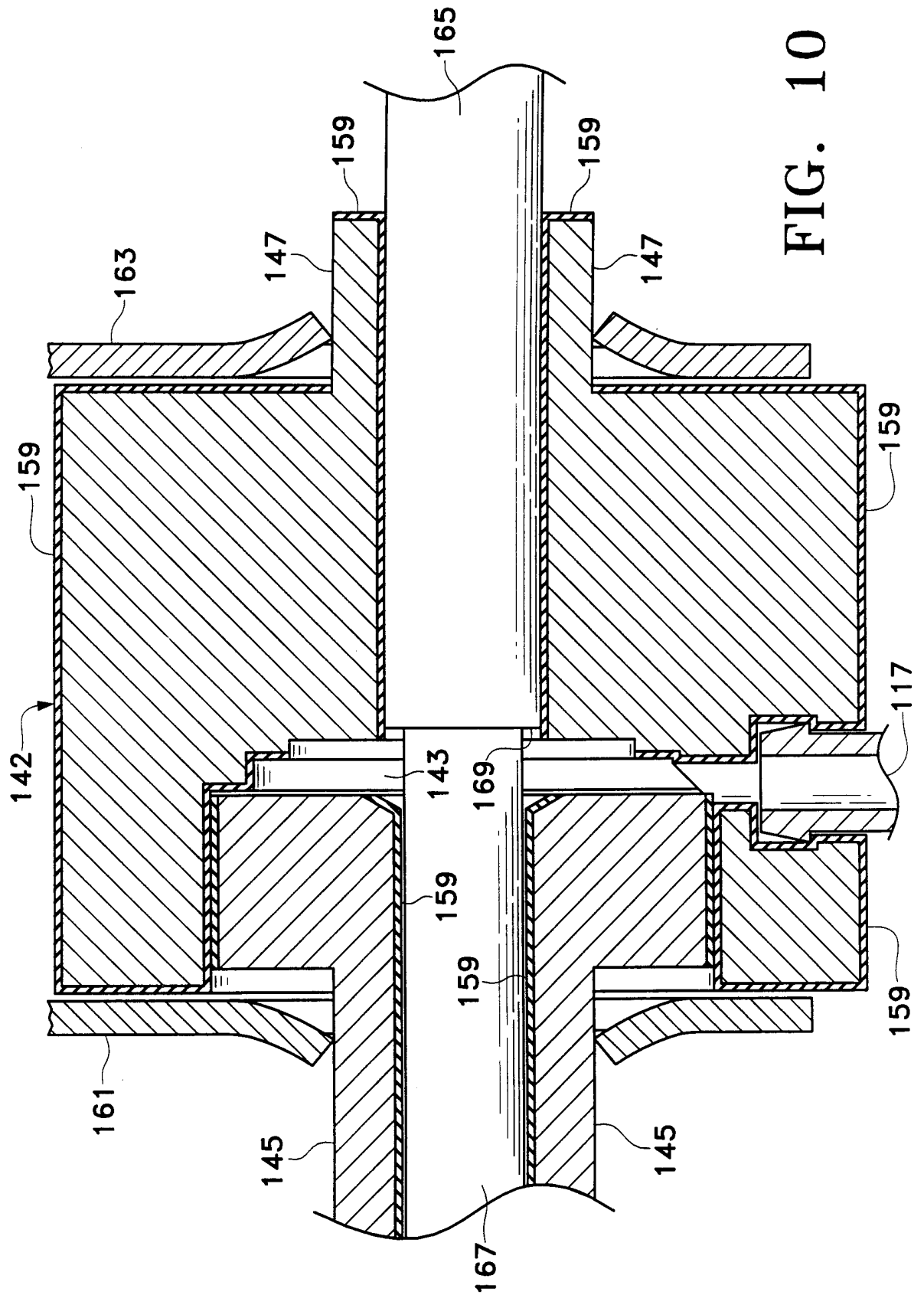

FIG. 10

9/12

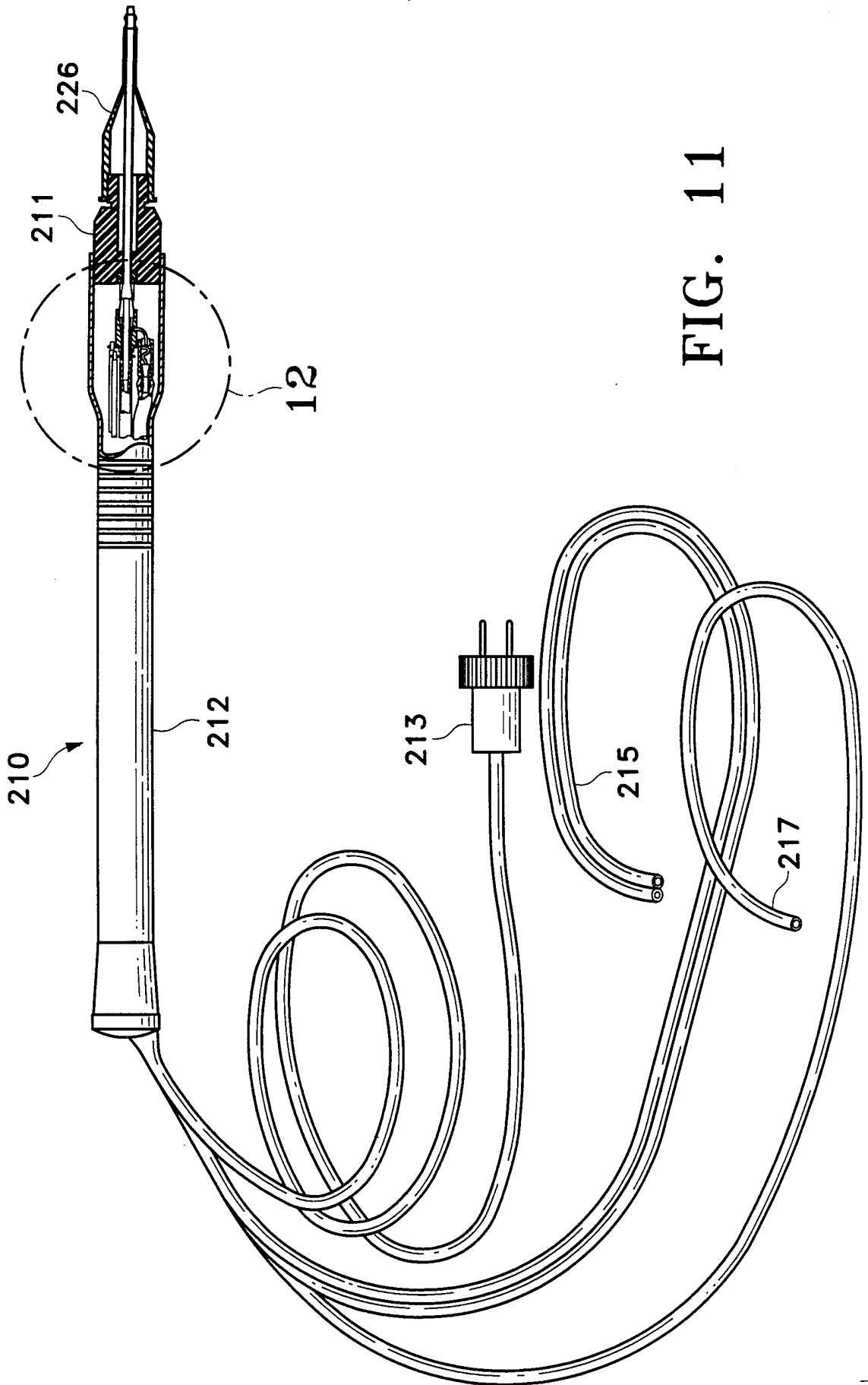

FIG. 11

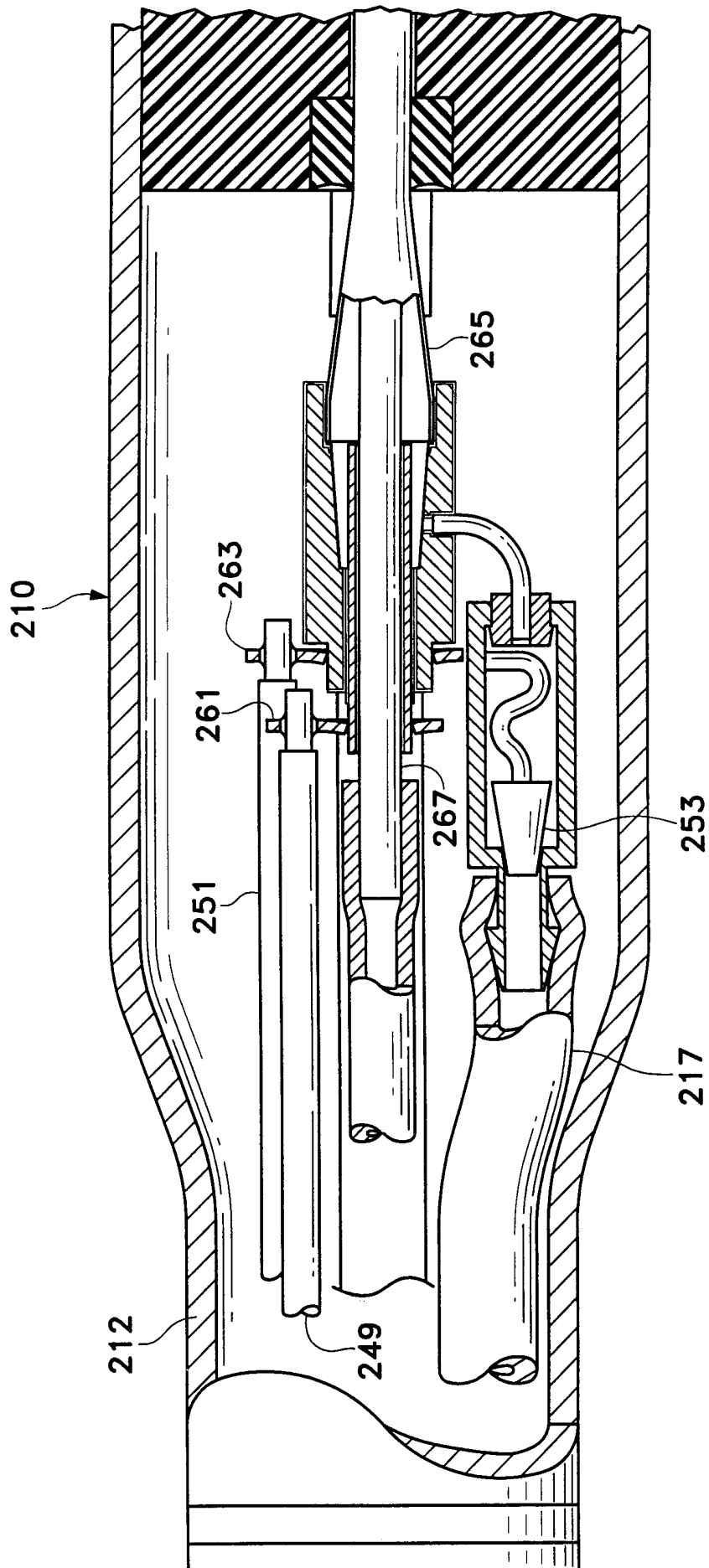

FIG. 12

11/12

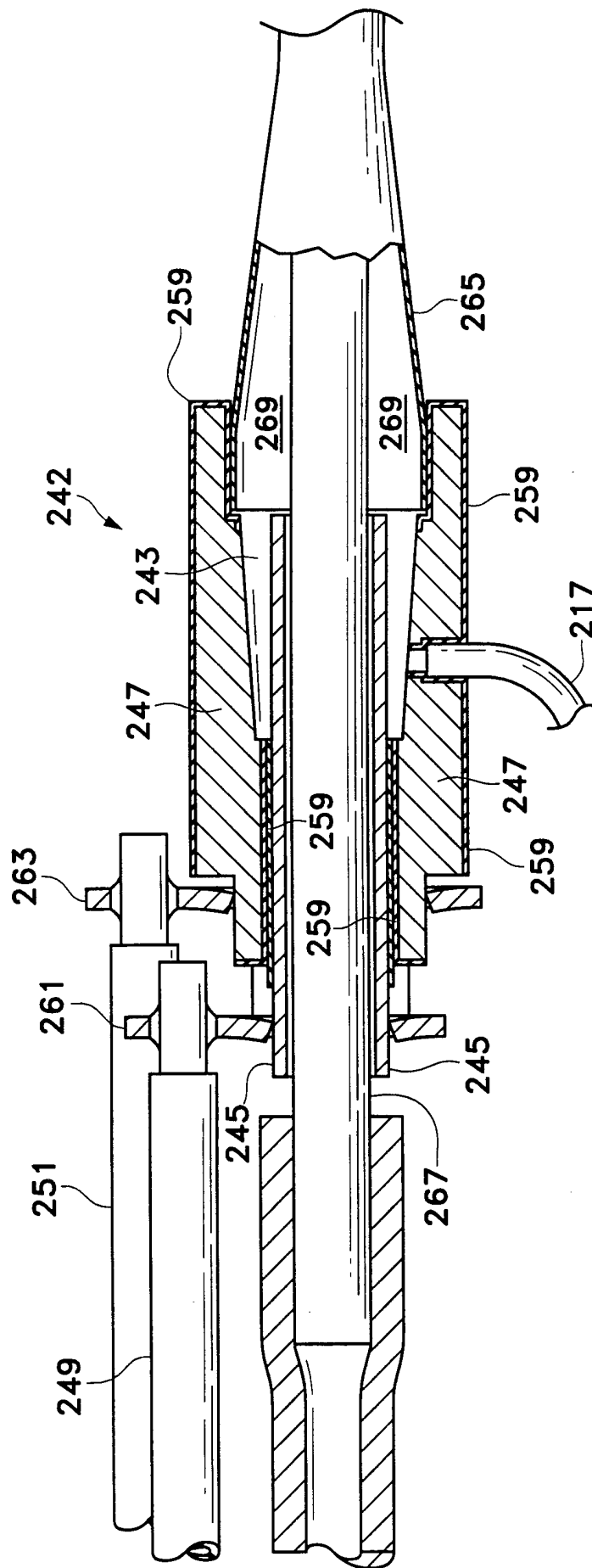

FIG. 13

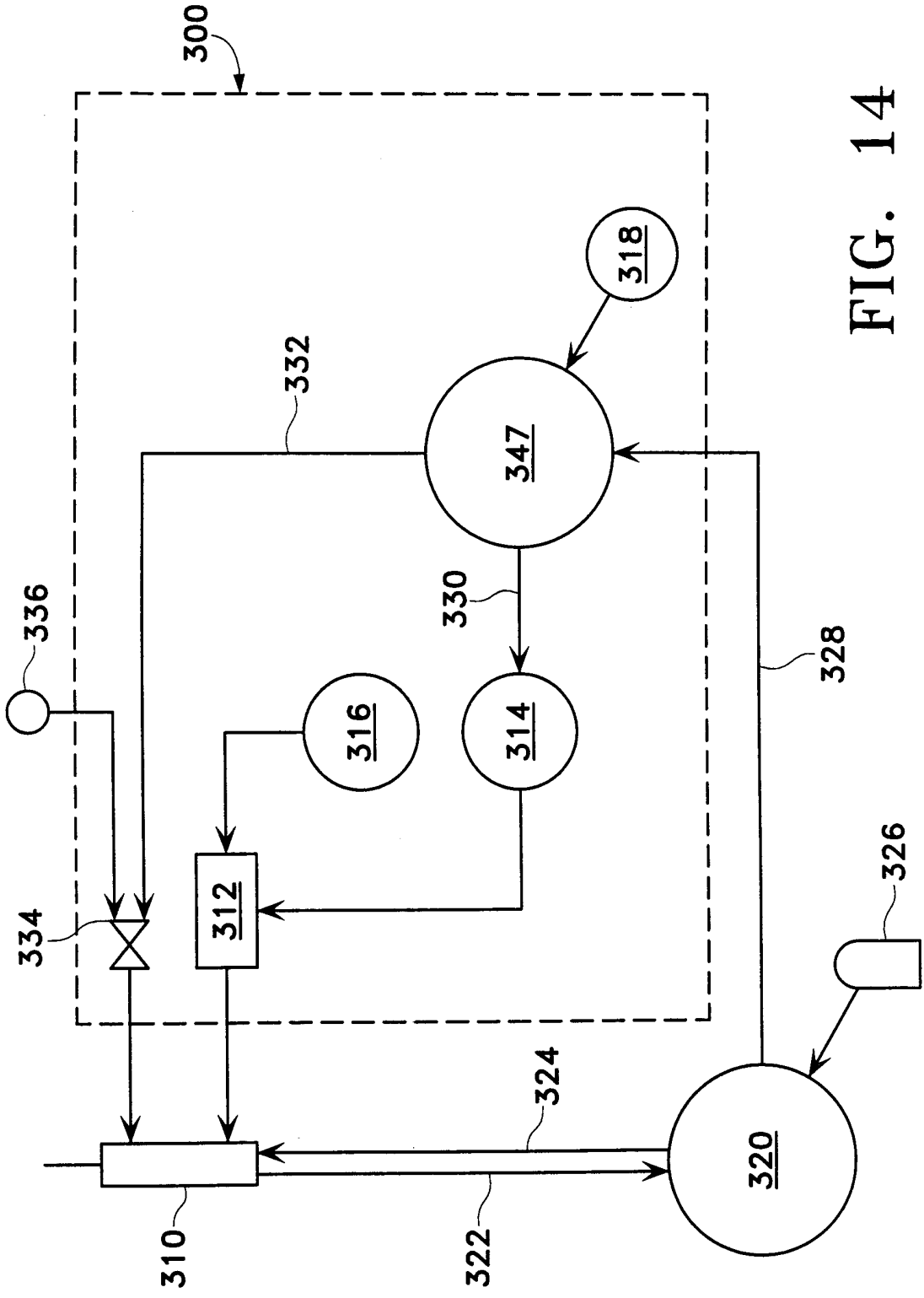

FIG. 14

INTERNATIONAL SEARCH REPORT

Intern. Application No

PCT/US 00/25709

A. CLASSIFICATION OF SUBJECT MATTER
 IPC 7 A61F9/007 F04F1/18

According to International Patent Classification (IPC) or to both national classification and IPC

B. FIELDS SEARCHED

Minimum documentation searched (classification system followed by classification symbols)

IPC 7 A61F A61B F04F

Documentation searched other than minimum documentation to the extent that such documents are included in the fields searched

Electronic data base consulted during the international search (name of data base and, where practical, search terms used)

EPO-Internal

C. DOCUMENTS CONSIDERED TO BE RELEVANT

Category °	Citation of document, with indication, where appropriate, of the relevant passages	Relevant to claim No.
Y	US 5 885 243 A (CAPETAN) 23 March 1999 (1999-03-23) cited in the application	1,2
A	column 3, line 38 - line 54; figure 4 ---	6,11
Y	GB 1 445 488 A (WALLACH) 11 August 1976 (1976-08-11)	1,2
A	figure 4 ---	6,11
A	US 5 616 120 A (ANDREW) 1 April 1997 (1997-04-01) cited in the application the whole document ---	
A	US 5 735 815 A (BAIR) 7 April 1998 (1998-04-07) ---	
	-/--	

Further documents are listed in the continuation of box C.

Patent family members are listed in annex.

° Special categories of cited documents :

- *A* document defining the general state of the art which is not considered to be of particular relevance
- *E* earlier document but published on or after the international filing date
- *L* document which may throw doubts on priority claim(s) or which is cited to establish the publication date of another citation or other special reason (as specified)
- *O* document referring to an oral disclosure, use, exhibition or other means
- *P* document published prior to the international filing date but later than the priority date claimed

- *T* later document published after the international filing date or priority date and not in conflict with the application but cited to understand the principle or theory underlying the invention
- *X* document of particular relevance; the claimed invention cannot be considered novel or cannot be considered to involve an inventive step when the document is taken alone
- *Y* document of particular relevance; the claimed invention cannot be considered to involve an inventive step when the document is combined with one or more other such documents, such combination being obvious to a person skilled in the art.
- *&* document member of the same patent family

Date of the actual completion of the international search

15 December 2000

Date of mailing of the international search report

02/01/2001

Name and mailing address of the ISA

European Patent Office, P.B. 5818 Patentlaan 2
 NL - 2280 HV Rijswijk
 Tel. (+31-70) 340-2040, Tx. 31 651 epo nl,
 Fax: (+31-70) 340-3016

Authorized officer

Barton, S

INTERNATIONAL SEARCH REPORT

International Application No

PCT/US 00/25709

C.(Continuation) DOCUMENTS CONSIDERED TO BE RELEVANT

Category *	Citation of document, with indication, where appropriate, of the relevant passages	Relevant to claim No.
A	US 5 865 790 A (BAIR) 2 February 1999 (1999-02-02) ---	
A	US 4 959 526 A (KURACHI) 25 September 1990 (1990-09-25) -----	

INTERNATIONAL SEARCH REPORT

Information on patent family members

Intern. Patent Application No

PCT/US 00/25709

Patent document cited in search report	Publication date	Patent family member(s)	Publication date
US 5885243 A	23-03-1999	AU 716239 B	24-02-2000
		AU 5100898 A	03-07-1998
		EP 0948300 A	13-10-1999
		WO 9825557 A	18-06-1998
GB 1445488 A	11-08-1976	NONE	
US 5616120 A	01-04-1997	AU 704305 B	22-04-1999
		AU 4691596 A	27-08-1996
		CA 2211031 A	15-08-1996
		EP 0812169 A	17-12-1997
		JP 10513091 T	15-12-1998
		WO 9624314 A	15-08-1996
		US 6074358 A	13-06-2000
US 5735815 A	07-04-1998	WO 9844853 A	15-10-1998
		US 5865790 A	02-02-1999
		AU 677061 B	10-04-1997
		AU 6746894 A	02-02-1995
		CA 2127637 A	27-01-1995
		DE 69414924 D	14-01-1999
		DE 69414924 T	27-05-1999
		EP 0636345 A	01-02-1995
		ES 2125379 T	01-03-1999
		JP 7313520 A	05-12-1995
		US 5853384 A	29-12-1998
		US 5562692 A	08-10-1996
US 5865790 A	02-02-1999	US 5735815 A	07-04-1998
		AU 677061 B	10-04-1997
		AU 6746894 A	02-02-1995
		CA 2127637 A	27-01-1995
		DE 69414924 D	14-01-1999
		DE 69414924 T	27-05-1999
		EP 0636345 A	01-02-1995
		ES 2125379 T	01-03-1999
		JP 7313520 A	05-12-1995
		WO 9844853 A	15-10-1998
		US 5853384 A	29-12-1998
		US 5562692 A	08-10-1996
US 4959526 A	25-09-1990	JP 1723360 C	24-12-1992
		JP 4006850 B	07-02-1992
		JP 63014038 A	21-01-1988
		JP 1079542 A	24-03-1989
		JP 1709072 C	11-11-1992
		JP 3073792 B	22-11-1991
		US 4818845 A	04-04-1989
		DE 3878118 A	18-03-1993
		DE 3878118 T	15-07-1993
		EP 0309199 A	29-03-1989
		NO 884181 A, B,	22-03-1989