

[54] VALVE FOR DELIVERING METERED AMOUNTS OF AEROSOL MATERIAL FROM CONTAINERS THEREFOR

3,104,785 9/1963 Beard..... 222/402.2

[75] Inventor: Tomaso Ruscitti, Milan, Italy

Primary Examiner—Robert B. Reeves

[73] Assignee: Coster Tecnologie Speciali S.p.A., Milan, Italy

Assistant Examiner—Larry Martin

Attorney—Steinberg & Blake

[22] Filed: Apr. 13, 1971

[21] Appl. No.: 133,526

[57] ABSTRACT

[30] Foreign Application Priority Data
May 2, 1970 Italy 24095 A/70

Valve for delivering metered amounts of aerosol materials from containers therefor. The valve comprises two bodies fast with each other and defining two distinct chambers communicating with each other. One of the chambers is connected to the container for the material to be delivered by a conduit, in which a piston is movably accommodated and fast with the valve stem, and allowing or inhibiting the communication between said conduit and the chamber connected thereto whether the stem is at rest, or is pressed for the material delivery.

[52] U.S. Cl. 222/402.16, 141/20, 222/402.2

[51] Int. Cl. B65d 83/14, B65b 3/04

[58] Field of Search 141/3, 20; 222/394, 222/402.1, 402.2, 402.16, 402.24

[56] References Cited
UNITED STATES PATENTS

2,746,796 5/1956 Germani 222/402.2 X

6 Claims, 2 Drawing Figures

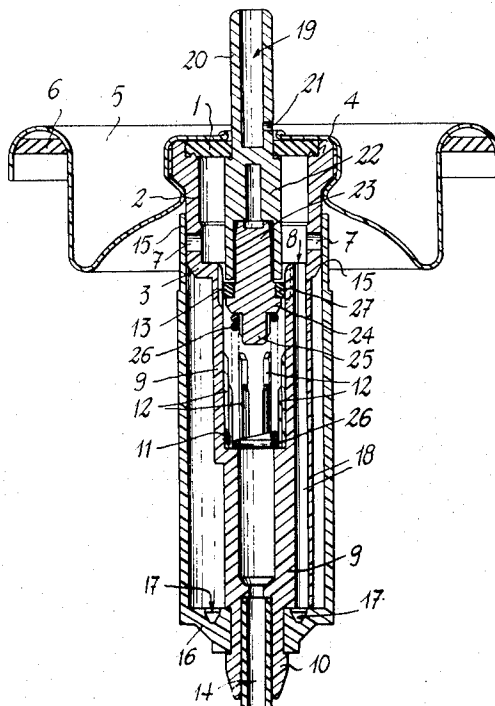

Fig. 2

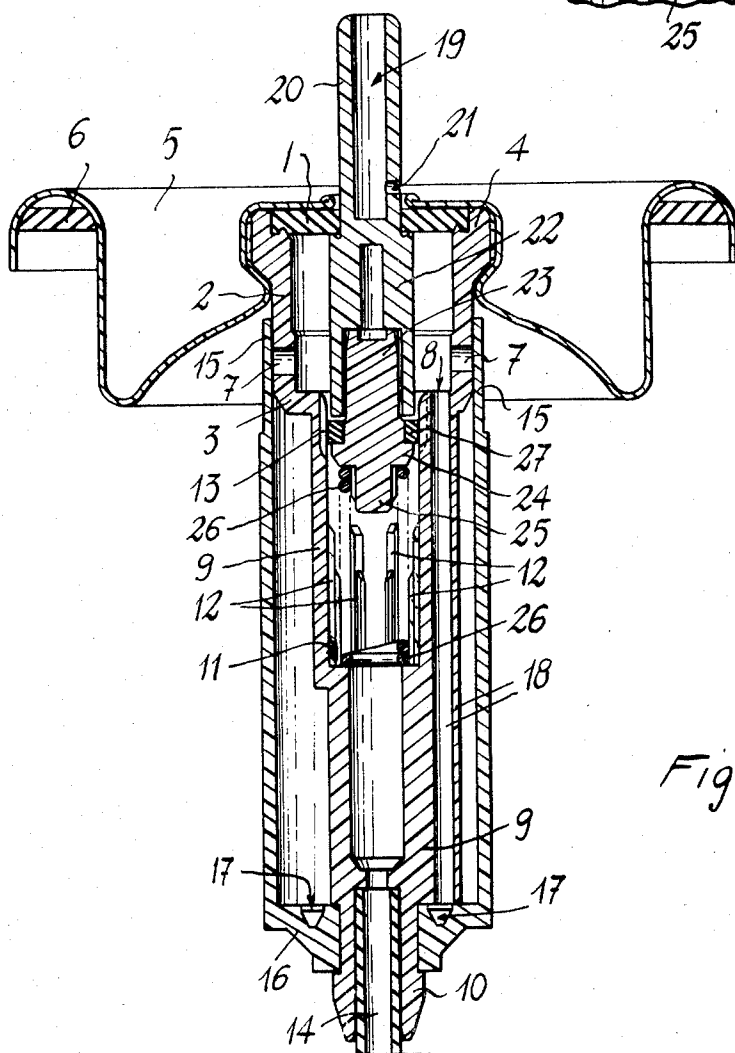
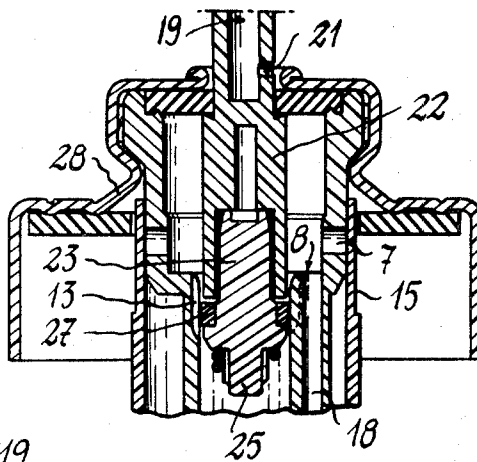

Fig. 1

INVENTOR.
TOMASO ROSCETTI
BY *Steinberg & Blake*
attorneys

VALVE FOR DELIVERING METERED AMOUNTS OF AEROSOL MATERIAL FROM CONTAINERS THEREFOR

This invention relates to a valve for delivering metered amounts of aerosol materials from containers therefor, and more particularly a valve which can be applied to aerosol containers to supply a metered amount of the product in the containers and by which said containers can be pressure loaded.

It is well known that an aerosol container loading can be effected in two different ways.

A first known loading method consists of introducing into the container a liquid propelling gas, at a low temperature, in addition to the material to be delivered. The delivery valve is then clamped to the container to isolate the interior of the container from the external environment. Obviously, when the container and material therein reach room temperature, the liquefied gas will change its state, pressurizing the vessel and thus placing the container under the conditions for enabling the delivery of the material in the bottle as an aerosol by operation of the delivery valve. This filling system suffers from substantial disadvantages, because of requiring expensive cooling systems for the propelling gas which should be brought to a very low temperature, frequently below -20°C , in order to be maintained at a liquid state. Moreover, by this filling system high propelling gas losses occur by evaporation when pouring off the liquefied gas into the container during the even minimal time between said liquefied gas pouring off into the container and container sealing by the delivery valve.

A second known method for filling an aerosol container consists of introducing pressurized propelling gas into the container through a metering-delivery valve previously attached to the container, into which the so-called "active" material of the aerosol product has been introduced prior to the sealing thereof by said delivery valve. Obviously, in order to fill a container by this second type of loading, it is required to use a valve having at least one element of deformable material which under the action of the external pressure is deformed during its loading step to allow for the introduction of liquid materials. Of course, this element should be only deformable to allow for introducing materials into the container.

It is well known that the materials comprising an aerosol product can very often attack the materials comprising the delivery valve applied to a container for such materials, causing not only the whole or part of the valve, but also the aerosol product deteriorate.

This drawback is very serious where valve elements of rubber are involved, but occurs also with other kinds of material.

The deterioration of the material in the bottle consists of flavorings, colorings and the like in the material, whereby the more a valve costs, the less the amount of rubber used therein, that is, taking into account that rubber is usually used for providing the valve seals, it can be stated that the more the value of a valve, the smaller the rubber seals said valve is provided with, since the rubber seals may contact the aerosol material.

Therefore, it is an object of the present invention to provide a delivery valve, by which accurately metered amounts of aerosol material can be delivered by a container for this material.

Another object of the invention is to provide a valve by which a propelling gas can be introduced into a container by means of a gas introduction, high speed pressure system, without any risk of damaging the valve, also in the presence of high pressures within the valve during the above operation.

A further object of the invention is to provide a valve using rubber elements which may contact the material in the bottle, but which have extremely reduced dimensions and wherein all the other parts forming said valve are made of plastic material obtainable for example by injection moulding, thus avoiding the more expensive blow moulding system.

A further object of the invention is to provide a valve comprising a plurality of distinct parts which are firmly interconnected by simple contact, such as by friction or joint, avoiding any heat-welding between two different members forming the valve.

These and still other objects are accomplished by a valve comprising an elongated inner body attachable to a bottom which, in turn, can be applied to an aerosol material container, an outer body mounted on the inner body and a stem, a portion of which is accommodated within a chamber in the inner body and another portion of which emerges from said chamber, this chamber being formed at an end of the inner body, having an inlet closed by an outer seal through which said stem passes, and being defined by a side wall and a bottom wall, in each of which at least a small hole is formed, said bottom wall also having an aperture of a larger size than said small holes forming one end of an elongated tubular wall extending outwardly of said chamber, an annular groove is formed on the outer surface of this tubular wall, while on the inner surface thereof a projecting step is provided and at least one longitudinal groove having a limited length, one end of the last mentioned groove terminating in said chamber and the other end thereof opening intermediate the ends of said tubular wall, said outer body being substantially cup-shaped with a free edge being resiliently deformable and overlying with pressure against the side wall defining said chamber, closing the small hole formed therein, the outer body in the form of a cup having a bottom provided with an aperture wherein said tubular wall of the inner body is inserted, at the annular groove of which said bottom is positioned and firmly sealingly mounted, an axial hole being formed in the portion of said stem emerging from said chamber and communicating with the outside through its free end and a small lateral hole extending from to the axial hole and formed in the wall of said stem adjacent that end of which internally beyond the chamber a small inner seal is mounted and a collar is provided, one end of a spring abutting thereon and the other end abutting on said step of said tubular wall. Under rest conditions of the valve said small lateral hole of the stem is positioned outside of said chamber, beyond the outer seal closing the inlet and said small inner seal on the stem is located nearer to said chamber than the end of said longitudinal groove which terminates between the ends of said tubular wall, said stem being movable in opposition to said spring to an operative position, where said small lateral hole opens inside said chamber and said small inner seal is positioned contacting a smooth surface zone of said tubular wall in sealing engagement therewith.

For a better understanding of the valve structure and features, an embodiment thereof will now be described, as given by mere way of not limiting example, reference being had to the accompanying drawing, in which:

FIG. 1 is an axial longitudinal sectional view showing an embodiment of the valve applied to a metal bottom; and

FIG. 2 is also an axial longitudinal sectional view showing a portion of the valve in FIG. 1, applied to a different bottom.

Referring first to FIG. 1, the axial longitudinal section is shown for a valve comprising an elongated inner body, at one end of which a chamber is formed having an inlet closed by a rubber outer seal 1 and defined by a side wall 2 and a bottom wall 3. The free edge of side wall 2 has an enlargement 4, to which a metal bottom 5 is claved and sealingly attachable due to the provision of a seal 6 on the inlet of an aerosol container. Two small holes 7 are formed in wall 2 and a small hole 8 is formed in the bottom wall 3, in which an aperture of larger size than hole 8 is also formed, with said latter aperture forming the top end of a tubular wall 9 extending outwardly of said chamber and, on the outer surface of which, adjacent its lower end, an annular groove is formed, below which the tubular wall has an annular lug 10. It will be also seen in the drawing that on the inner surface of the tubular wall 9 a projecting step 11 is formed, above which longitudinal ribs 12 project from the surface of wall 9. Longitudinal grooves 13 are then formed on the inner surface of the tubular wall 9, one end of each groove 13 opening in the chamber defined by walls 2 and 3 of the elongated body, and the other end terminating intermediate the ends of said tubular wall 9, as clearly shown in the drawing. Finally, it can be seen that at the lower end of the elongated body a cylindrical seat is formed, in which one end of a drawing tube 14 is inserted and housed, the other end of this tube being positioned adjacent the bottom of the container on which the valve is mounted. On the above described inner elongated body an outer body is carried, substantially in the form of a cup having a free edge 15 which is resiliently deformable and with pressure overlies and bears against the side wall 2 of the inner body, said free edge 15 closing the small holes 7 in the side wall 2. The outer cup-like body has a bottom 16 where an aperture is formed, wherein the tubular wall 9 of the inner body is inserted, at the annular groove of which said bottom is positioned and sealingly mounted and retained by the annular lug 10, as shown in the drawing. On the inner surface of bottom 16 of said outer cup-like body an annular groove 17 is formed, at which the lower end of a tube 18 is positioned fast with the tubular wall 9, and the other end of which opens at the hole 8 formed in the bottom wall 3 of the inner body.

The valve also comprises a stem, a portion of which is housed within the chamber defined by the walls 2 and 3 of the inner body, an another portion of which emerges from said chamber through a hole in the outer seal 1, the stem being made of two pieces, in one of which an axial hole 19 is formed in a stem portion 20 projecting beyond the bottom 5 and communicating with the outside through its free end and a small hole 21 extending laterally with respect to the axial hole is formed in the wall of the stem portion 20, the lower end 22 of said stem portion having a substantially cylindrical seat being formed therein, from which small longi-

tudinal ribs project and in which an extension 23 is forcibly inserted and firmly retained, this extension forming a part of the other stem portion or piece also comprising a collar 24, a small post 25 projecting from the center thereof and having on its outer surface a number of longitudinal ribs, on which some turns of a spring 26 are superimposed and forced, some other turns of which are accommodated and forced between the longitudinal ribs 12 projecting from the inner surface of the tubular wall 9.

Finally, it will be appreciated that on the stem extension 23 a small inner rubber seal 27 is carried and firmly retained in place between said collar 24 and the lower end of the stem portion or piece 22 and that, under the rest conditions as shown in the drawing, said spring 26 is slightly compressed and urges the stem outwardly of the valve, and more particularly urges against said seal 1 a shaped annular edge projecting from the lower end 22 of the stem, as clearly shown in the drawing.

Assume that the bottom 5 has been claved to the inlet of a container and a propelling gas is to be introduced under pressure and at high speed into said container. Through the use of known machines, the valve stem is lowered, that is the stem portion or piece 20 is partially re-entered into the interior of the chamber defined by the walls 2 and 3 of the elongated inner body, overcoming the strength of spring 26, until the small hole 21 is positioned within said chamber below the outer sealing gasket 1. The pressure gas is now supplied to the valve and enters said chamber flowing between the seal 1 and the surface of the stem portion or piece 20 and through the small hole 21, and from said chamber enters the container mostly through the small holes 7 after causing the resilient deformation of the edges 15 of the outer body, and to a less extent through hole 8, tube 18 and escaping again between the wall 2 and the free edge 15 which is resiliently deformed. It will be appreciated that, although the propelling gas pressure and its introducing speed are very high, the outer cup-like body is not separated from the inner body, because the anchoring between the two bodies is very strong and reliable, particularly due to the provision of said annular lug 10 and also due to the high frictional force between the wall 2 and edge 15 of the two bodies.

It will be also appreciated that, as the propelling gas is introduced into the container in the above mentioned manner, said small inner seal 27 is positioned below the lower end of the longitudinal grooves 13 on the tubular wall 9, and more particularly said seal is contacting a smooth surface zone at a cylindrical portion of the inner surface of said wall 9, said gasket providing for a complete sealing therewith.

Assume now that the valve is mounted on a ready-to-use container and a delivery cap of any known shape is mounted on the stem portion or piece 20. Under the rest conditions shown in the drawing, the propelling gas enclosed within the container, to which the valve is applied, causes the liquid or active material to move up through the bore of the drawing tube 14, through the bore or cavity of the tubular wall 9, causing it to flow into the grooves 13 and through the latter into the chamber as defined by said walls 2 and 3, and then causing it to enter the hole 8 and tube 18 and, through the latter, the gap between the inner and outer bodies of the valve, that is the space defined by the bottom wall 3 and the tubular wall 9 of the inner body and the

walls of the outer cup-like body. Under these conditions, the aerosol material cannot come out of the axial stem hole 19, since the small hole 21 of said stem is positioned above the valve seal 1.

Suppose now to cause by a finger the valve stem lowering in opposition to said spring 26, until the small hole 21 is positioned within the chamber defined by said walls 2 and 3 and seal 1. Under these conditions, the aerosol material in the above mentioned chamber will flow to the delivery cap nozzle from the small hole 21 and axial hole 19 of the stem from the tube 18 and the gap between the inner and outer bodies of the valve. This aerosol material is forced out of the valve because of the pressure of a gas portion which may be present in the gap between the inner and outer bodies of the valve and also because of the liquid and gas pressure in the container, causing the deformation, or better the crushing of the outer cup-like body of the valve which is made of deformable plastic material. It will be also appreciated that, as the aerosol material delivery occurs through the valve stem, the small rubber seal 27 is positioned below the lower end of grooves 13, as previously mentioned, providing for a sealing relationship with the cylindrical smooth surface of a portion of said tubular wall 9 and preventing the liquid below said seal and within the drawing tube 14 from flowing into the chamber as defined by walls 2 and 3.

As soon as the delivery of aerosol material ceases through the valve stem hole and as soon as said stem is released to return to the rest position as shown in the drawing, the liquid in the container can flow through the grooves 13 and fill again the chamber and the valve gap.

As it will be readily understood, it is possible by the above described valve to delivery accurately metered amounts of aerosol materials and a pressurized, high speed propelling gas can be as well readily introduced into the container, after the valve has been clawed thereon.

It is also important to note that the sizes for the seals which may contact the liquid enclosed in the container, particularly the sizes of the rubber seals 27 and 1, are highly reduced and thus the occurrence of reactions between the rubber material of the seals and the material enclosed in the container is minimized.

It is also important to note that the cross sectional sizes for the outer cup-like body, that is the cross sectional sizes for that portion of said body projecting from bottom 16, may be different, thus making it possible to simply and readily provide valves for delivering predetermined different amounts of aerosol material.

It will be also seen from the drawings that all of the elements comprising the valve can be readily made of plastic material by injection moulding, thus avoiding the more expensive blow moulding system; it is also extremely important to note that all of the elements comprising the valve are firmly coupled to one another by simple contact, any heat-welding between two different parts of the valve being avoided.

Besides simplifying the manufacture of the stem, the two-piece structure of said stem provides a simpler assembling thereon for the seal 27 which can be mounted on the extrusion 23 prior to the latter being inserted in the seat of the lower stem end 22.

The above described valve has been shown in FIG. 1 as secured to such a bottom 5 which can be clawed on

a container inlet by upsetting said bottom from inside to outside.

In FIG. 2 of the accompanying drawing a valve has been shown identical to that described in FIG. 1, but wherein said valve is mounted on a bottom 28 which can be clawed on a container inlet by upsetting said bottom from outside to inside.

Therefore, the valve can be adapted and readily mounted on the two types of commonly used bottoms and it is important to note that the actual delivering-metering valve portion is rigidly secured to a bottom, without taking advantage of or depending in the least on the coupling between the bottom and aerosol container for carrying out such a fastening.

What I claim is:

1. A valve for delivering metered amounts of material from aerosol containers, comprising an elongated hollow inner body having an interior chamber and being attachable to a bottom which, in turn, can be applied to an aerosol container, an outer body mounted on the inner body and a stem, a portion of which is accommodated within said chamber in the inner body and another portion of which emerges from said chamber, this chamber being situated at an end of the inner body and having an inlet, an outer seal closing said inlet and said stem passing through said outer seal, and said chamber being defined by a side wall and a bottom wall, in each of which at least one small hole is formed, said bottom wall also having an aperture of a larger size than said small holes, and an elongated tubular wall having an open end formed by said aperture of larger size and extending outwardly of said chamber and having an outer surface formed with an annular groove, while said tubular wall has at an inner surface thereof a projecting step and is formed with at least one longitudinal groove having a limited length, one end of the last mentioned groove opening into said chamber at said aperture of larger size and the other end thereof terminating intermediate the ends of said tubular wall, the latter having a smooth surface zone inwardly beyond said longitudinal groove, and said outer body being substantially cup-shaped and having a free edge resiliently deformable and overlying with pressure the side wall defining said chamber, closing the small hole formed therein, the outer body in the form of a cup having a bottom formed with an aperture wherein said tubular wall of the inner body is inserted, and said bottom of said outer body being positioned and firmly and sealingly mounted in said annular groove of said elongated tubular wall, said stem being formed with an axial hole in the portion of said stem emerging from said chamber and communicating with the outside through its free end and said stem being formed with a small lateral hole extending laterally from the axial hole and formed in the wall of said stem distant from said free end of said stem, a small inner seal mounted on said stem at a portion thereof situated in the interior of said elongated tube inwardly beyond said chamber and a collar on said stem at the side of said small inner seal opposite from said chamber, a spring abutting at one end against said collar and at the other end abutting on said step of said tubular wall, said small lateral hole of the stem being positioned under rest conditions of the valve outside said chamber, beyond said outer seal closing the inlet, and said small inner seal on the stem being nearer to said chamber than said other end of said longitudinal groove, said stem being movable in

opposition to said spring to an operative position, where said small lateral hole opens inside said chamber and said small inner seal is positioned contacting said smooth surface zone of said tubular wall, in sealing engagement therewith inwardly beyond said longitudinal groove.

2. A valve according to claim 1, wherein said bottom wall of said chamber of the inner body has a tube extending therefrom, one end of said tube opening at said small hole in said bottom wall and the other end of which opening adjacent the bottom of the outer cup-like body.

3. A valve according to claim 2, wherein a groove is formed in said bottom of the outer body, a portion of the groove being positioned adjacent said other end of said tube.

4. A valve according to claim 3, wherein said stem is made of two pieces coupled to each other, one of which

having a substantially cylindrical seat and the other of which having an elongated extension which can be inserted and accommodated in said seat and on which said small inner seal is mounted.

5. A valve according to claim 4, said elongated tubular wall having longitudinal ribs projecting from an inner surface portion thereof, wherein a small cylindrical post extends from the center of said stem collar, small longitudinal ribs projecting from said post and having forcibly superimposed thereon at least one turn of an end of said spring, at least one turn of the other end of said spring being forcibly accommodated between said longitudinal ribs projecting from the inner surface of said tubular wall.

6. A valve according to claim 5, wherein said outer body is made of resiliently deformable plastic material.

* * * * *

20

25

30

35

40

45

50

55

60

65