

(No Model.)

2 Sheets—Sheet 1.

F. W. HILLARD.
TYPE WRITING MACHINE.

No. 577,982.

Patented Mar. 2, 1897.

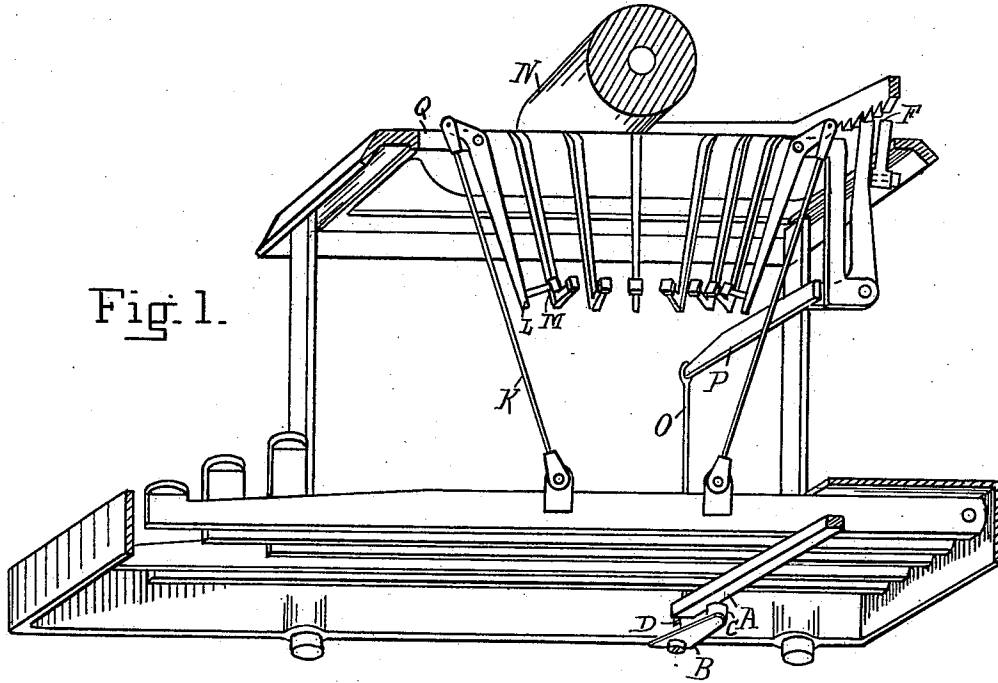

Fig. 1.

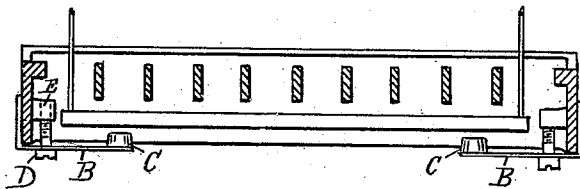

Fig. 2.

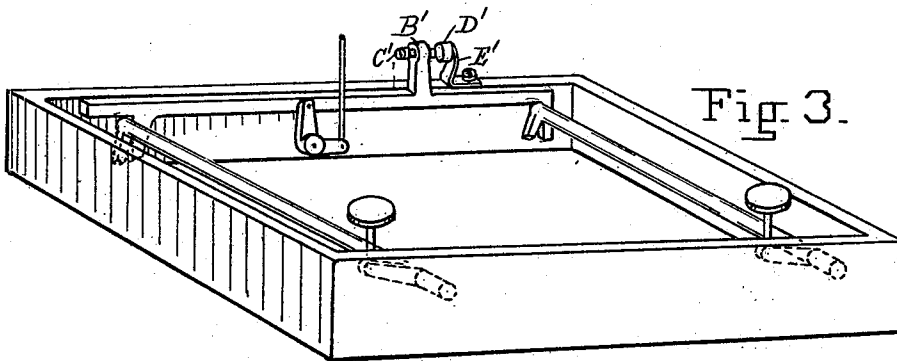

Fig. 3.

Witnesses—

S. W. Balch
Malvina B. Balch

Inventor,
Frederic W. Hillard
by *Thomas Swing*
Attorney.

(No Model.)

2 Sheets—Sheet 2.

F. W. HILLARD.
TYPE WRITING MACHINE.

No. 577,982.

Patented Mar. 2, 1897.

Fig. 4.

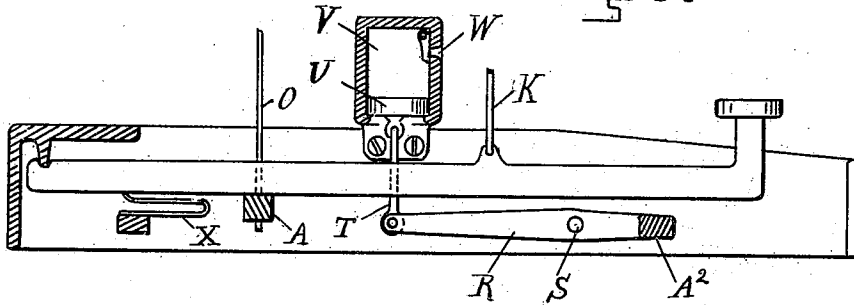

Fig. 5.

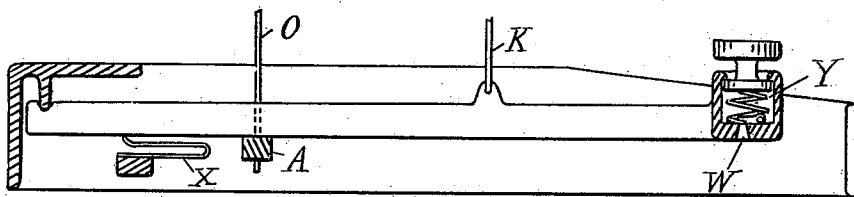
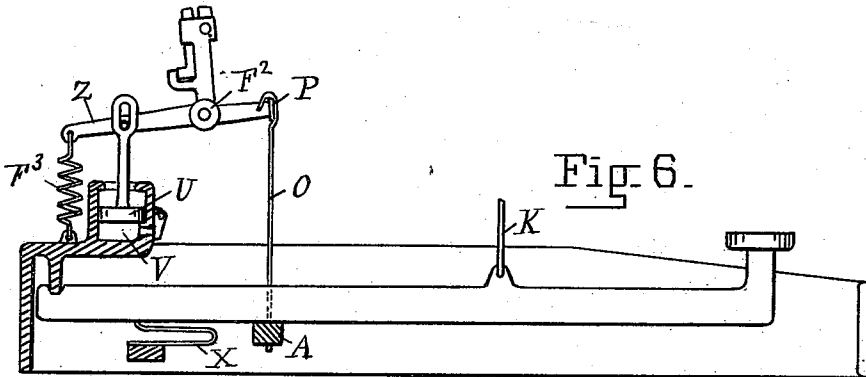

Fig. 6.



Witnesses
Samuel W. Balch
Willard P. Shaw

Inventor
Frederic W Hillard
 by *Thomas Ewing Jr*
 Attorney.

UNITED STATES PATENT OFFICE.

FREDERIC W. HILLARD, OF NEWARK, NEW JERSEY.

TYPE-WRITING MACHINE.

SPECIFICATION forming part of Letters Patent No. 577,982, dated March 2, 1897.

Application filed November 16, 1891. Serial No. 412,018. (No model.)

To all whom it may concern:

Be it known that I, FREDERIC W. HILLARD, a citizen of the United States of America, residing at Newark, Essex county, New Jersey, have invented certain new and useful Improvements in Type-Writers, of which the following is a specification.

My invention is an improvement in type-writing machines constructed to feed the paper during the stroke on the key, the object of the invention being to prevent the type from striking the paper two or more times during a single depression of the key or from being inadvertently held against the paper, and thus to avoid multiple impressions and blurring in the print. The joints between the key-lever, connecting-wire, and type-bearer are all generally somewhat loose, and the type-bearer thus has a certain play independent of the key. Therefore in machines constructed to feed the paper during the stroke if a key be inadvertently held down after a blow the type will either rebound and strike the paper one or more times after the first impression has been made, thereby causing, besides the primary impression which should appear, a secondary distinct though fainter impression, which is extremely objectionable, or else by being held continually against the paper it will cause a blur in the print. Holding the key down also causes the machine to act more sluggishly, since the force of the rebound of the type from the inking-ribbon or paper, which should return the type-bearer quickly to normal position, is lost, and the additional motion of the type-bearers increases the rattling of the machine and impairs the alinement of the printing. Also when a key is driven down forcibly by a blow and where the operator continues to force the key down farther and farther, as he is naturally inclined to do, until the type strikes on the paper, the key is then brought to an abrupt stop. This jars the machine and jars the operator and if continued for several hours on the stretch daily comes to be very wearing nervously and hard on the fingers. All of these defects—viz., double printing, blurring, sluggishness, and abrupt stoppage of the keys—can be avoided by cultivating the staccato stroke, which does not drive the key

through its entire path and does not hold it down at all. This does not interfere with the printing for the type-bearer acquires sufficient momentum during the first half or three-quarters of a stroke to carry the type against the paper and print; but even an expert operator must acquire a special touch to print thus with perfect clearness, and after having acquired the touch will not always practice it when subjected to interruptions or wearied by long-continued work.

The action of the type-bearer may be likened to that of a hammer on an anvil. If an attempt be made to hold the hammer down when a blow is struck, it will strike the anvil repeatedly; but if the hammer be allowed to spring back without resistance there will be but one sharp blow. In the former case the momentum of the hammer will be expended in repeated and useless blows, while in the latter case that energy will be utilized in returning the hammer into position for the next blow.

It is my aim to so construct a machine that any operator without acquiring a special stroke can, while working at high speed, produce clear printing; and my invention consists, broadly, in adding a device which will produce a noticeable recussion or retraction of the key when it has been so far depressed as to throw the type against the paper with sufficient force for good printing, and will thus cause any operator to lift the finger instinctively—i. e., it will make the staccato the natural stroke. In the claims I call such a device a "repulser."

My invention consists, further, in the specific devices for accomplishing the result herein described and shown.

The accompanying drawings, which form a part of this specification, show my invention applied to a Remington and a Smith Premier machine, but a skilled mechanic will readily apply it to any style of type-writing machine.

Figure 1 is an elevation of one-half of the Remington seen from below. Fig. 2 is a cross-section of the lower part of the machine shown in Fig. 1 on the line of the universal bar. Fig. 3 is an elevation of the lower part of the Smith Premier machine seen from above. Figs. 4, 5, and 6 are detail views of modifica-

tions of the Remington construction, showing pneumatic and gravity repulsers.

In all of the above figures my invention is shown.

5 In Fig. 1, A is the universal bar, which is depressed by each of the keys and operates the escapement. Beneath this bar, as shown in Figs. 1 and 2, I attach firmly to each of the sides of the base, by screws or otherwise, a
10 stiff spring B, preferably of resilient metal, which projects under the bar and carries on its end a tip C, preferably of rubber. This spring is adjusted in position by a set-screw
15 D, which passes through a hole in the spring and engages with a lug E, cast on or firmly attached to the side plates and properly threaded to receive the screw.

F is a reversed escapement. As shown, the
20 detaining-dog engages the rack while the machine is at rest and the spacing-dog engages the rack upon depressing the key. Thus the paper is fed forward during the stroke instead of after the stroke, as is more common.

In this specification I designate an escape-
25 ment in which the detaining element in one of the members (herein shown as a detaining-dog) normally engages with the other member (herein shown as a rack) while the machine is at rest, as a "reversed" escapement,
30 in contradistinction to the "old" or "ordinary" escapement, which is one wherein the spacing element normally engages the other member while the machine is at rest. The reversed escapement is now also very commonly designated commercially as a "speed-
35 escapement."

The meaning of the terms "reversed escapement" and "speed-escapement" should not, however, be confounded with one another,
40 since the term "speed-escapement" covers a broader meaning than does the term "reversed escapement."

In the United States patent to G. B. Webb, No. 555,138, dated February 25, 1896, the
45 term "reversed escapement" is used and a certain limited and fixed definition given thereto—viz., an escapement in which the carriage is released for its whole letter-space feed prior to the printing. Thus, for exam-
50 ple, the escapement shown in Fig. 1 is a reversed escapement. On the other hand, a "speed-escapement" may be defined as one constructed to release the carriage for all or a substantial part of its letter-space feed
55 prior to the printing, and I include within the meaning of the last-named term all escapements which permit a substantial feed of the carriage prior to the printing, that is to say, which permit the carriage to feed forward prior to the printing so far as to cause
60 blurring or double impressions in the print. In the Smith Premier type-writer (illustrated in Fig. 3) the escapement (not shown) is of the form illustrated and described in United
55 States patent to A. T. Brown, No. 436,333, dated September 16, 1890, and with this lat-

ter escapement the best results are obtained with my repulser by so adjusting the two dogs that the carriage is released for one-half of its feed prior to the printing and for the other half of the feed after the printing,
70 since this arrangement gives a feed substantially as fast and much smoother than a reversed escapement. The Smith-Premier escapement arranged in this manner is a speed-
75 escapement, but does not come within the meaning of the term "reversed escapement" as defined in the Webb patent cited.

I include reversed escapements within the meaning of the term "speed-escapement" in the sense in which I use the terms in the
80 claims.

The other parts of the machine are as follows: K is the connecting rod or wire between the key-lever and the type-bearer L.
85 M indicates the type. N is the printing-platen; O, the connecting-rod which joins the universal bar and the bar P, that operates the spacing-rocker carrying the dogs. Q is the hanger, to which the type-bearer is piv-
90 oted.

In Fig. 3 there is attached to the gate or universal bar of the Smith Premier a lug B', through the upper end of which passes an ad-
95 justing-screw C', which impinges against the rubber tip D' on the face of the spring E', erected on the rear plate on the base of the machine.

The springs in the above figures should be so adjusted as to come into action somewhat
100 before the type strikes the paper or inking-ribbon and should be strong enough to act sharply, as they have but short time in which to act. The effect is as follows: At first they yield to the blow of the finger and do not
105 interfere with the printing, if correctly set, but immediately they tend to fly back to normal position. In so doing they press upward the key-lever and finger. The finger is thus started back just at the right time to prevent
110 holding the key down and thereby causing the rebound of the type-bearer and the attendant double printing, blurring, sluggishness, and jarring above referred to. This is all that an operator needs to cause him to
115 withdraw his finger, as I have found by practice. The looseness in the joints between the key-lever and connecting-wire and between the connecting-wire and the type-bearer permits the type to be carried up or finish its
120 excursion to the printing-center to print under the force of the momentum even after the key-lever has been started back toward normal position by the repulser.

It will be obvious that there is considerable
125 latitude as to form, location, and manner of attachment of the springs. Thus in Fig. 4 there is shown a modification of the Remington machine in which the universal bar A² is placed under the front end of the key-levers,
130 being firmly fastened to the lever R, which is pivoted on the shaft S. At the rear end

the lever R is hinged to the perpendicular piston-rod T. At its upper end the piston-rod is hinged to the piston U. When a key has been so far depressed as to contact with the universal bar A², thereby depressing it, the piston is forced up into the cylinder V, compressing the air contained therein and so effecting the recussion of the key. The weight of the piston assists in returning the repulser to normal position, and there is a valve W opening inwardly into the top of the cylinder, which allows the air-chamber to become completely refilled in case any leakage occurs.

Fig. 5 shows a repulser acting on the key-lever directly. In this modification there is an air-chamber on top of the front end of the key-lever, and the stem of the key acts as the piston. When a blow is struck, the key is depressed until the pressure of the air on the key-lever becomes great enough to overcome the key-lever-retaining spring X. Then the key-lever is depressed and the type-bearer is driven up until the type strikes on the paper, and as the key is depressed still farther into the air-chamber the repulser effect immediately follows. A slender spiral spring Y assists in returning the key to normal position, and the cylinder is provided with the valve W, opening inwardly:

In Fig. 6 the rocker-frame F² is provided with the rearwardly-extending arm Z, connected with the piston U in the cylinder V. The pin on the rearwardly-extending arm of the spacing-rocker travels from the bottom to the top of the slot in the upper end of the piston-rod on depression of a key and thus prevents any action of the repulser on the key until about the time the type impinges on the platen. Gravity and the retaining-spring F³ cooperate to return the parts to normal position.

It will be noticed that in the repulser shown in Figs. 4, 5, and 6 in some of the cylinders the air is compressed, while in others it is rarefied, and that in Figs. 4 and 6 gravity assists in returning the parts to normal position. In Figs. 4 and 6 the pistons may be made very much heavier than shown, and they may be fitted loosely into the cylinders. Then the repulser effect will follow from gravity alone.

It is immaterial what force is employed to effect the recussion of the key. Thus the force of gravity may be utilized by weighted levers to give the desired rebound to the key and finger or the force of resilient metal or the force of compressed air, all as described and shown herein.

It will be noticed also that the repulsers shown in Figs. 1, 2, 3, 4, and 6 all act on a universal bar, but that the repulser shown in Fig. 5 does not act on a universal bar. It is not necessary that the universal bar on which the repulser acts shall be the one attached to the spacing-rocker frame. Thus there may

be two universal bars, one to operate the escapement and the other to be operated on by the repulser. In Fig. 4, A represents the universal bar which operates the escapement, and A² the universal bar for the repulser.

While the repulser may be advantageously arranged to act on other parts of the machine, (for instance, directly on the keys, as in Fig. 5,) still there are particular advantages in applying it to the universal bar. The universal bar, and through it the escapement, is the only part of the machine which is acted upon by each of the keys and which is suitable as a seat for the repulser. (In a type-bar machine the universal bar is the only part acted on by all the keys, while in a type-wheel machine the type-wheel is operated by all of the keys; but the repulser cannot be attached to the type-wheel mechanism conveniently without interfering with the impact of the type on the platen.) Hence a single repulser-spring arranged to act on the universal bar will transmit the recussion to whichever key may be depressed.

It is not necessary that the repulser act directly on the universal bar. It may be attached to any part of the escapement, and through the escapement act on the universal bar, and thus transmit the recussion to the key. Thus in Fig. 6 the repulser is attached on the rearwardly-extending arm of the spacing-rocker.

My repulser should be carefully distinguished from the other parts in the machine which tend to hold up the key or to lift it after it has been depressed. For example, I have shown my invention as applied to the Remington type-writer. In this machine there are several parts which act on the key to hold it up and to lift it after it has been depressed. Thus there are the lifting-springs fixed under the several key-levers, which hold the keys up and which must be compressed as soon as the keys begin to be depressed. Then there is a spring attached to the spacing-rocker, which holds one of the dogs normally in engagement with the rack when the machine is at rest and which returns that dog into engagement with the rack after they have been disengaged from one another by the depression of the key. Also in addition to these two springs (the key-lever-lifting spring and the spacing-rocker-retaining spring) there is the carriage-mainspring. This spring pulls the rack forcibly against the dog with which it normally engages, so that a considerable force on the key is required to disengage them. The combined force of all three of these springs, as well as the inertia of the type-bar and other parts operated, has to be overcome by the blow on the key in order to drive the type against the platen and print and to vibrate the spacing-rocker, so that the carriage may be fed forward by its mainspring. It is of course desirable to utilize as large a part of the force of the blow on the key as possible to effect

the printing. Therefore the key-lever-lifting spring, the spacing-rocker-retaining spring, and the carriage-mainspring are all tensioned as lightly as is possible consistent with a sufficiently speedy action of the parts. On the other hand my repulser does not offer any resistance to the key until the requisite momentum has been imparted to the type-bearer. Then the repulser comes into action and produces a noticeable recussion on the key, but it offers little or no resistance to the impact of the type on the platen.

Any spring or other force which is brought into action with the key after the key has been so far depressed as to impart momentum to the type-bearer sufficient to effect clear printing, and after it has disengaged the engaging members in the escapement, so as to insure the spacing of the platen, and which then imparts a recussion to the key, comes within the meaning of the term "repulser" as I make use of that term in the claims. I wish it to be understood, however, that the parts may be so arranged or adjusted that when a quick or staccato blow is struck on the key and the key only partially depressed the repulser will not be brought into action at all.

While my repulser should be so arranged as not to check the type-bearer or interfere with the printing, it does not follow that it should not act on the type-bearer after the impact of the type on the platen. On the contrary, the repulser may be of very material assistance after the printing has taken place in promptly returning the type-bearer into the type basket or buffer, where it normally rests when not in use. Thus in Fig. 1 the repulser comes into use somewhat before the type strikes on the platen, thus starting the key back to its normal position before the printing has taken place; but the looseness in the joints between the key-lever and connecting-wire and between the connecting-wire and the type-bar permits the type to be carried up and finish its excursion to the platen after the key-lever has been started back to its normal position. This movement of the key back to its normal position while the type-bar is still carrying the type toward the platen results in the taking up of the looseness or play between the key-lever and the type-bar. Hence the recussion which has been imparted from the repulser to the key-lever is transmitted from the key-lever to the type-bar after the impression of the type on the paper and assists in returning the type-bar quickly to its position of rest in the basket.

There are particular advantages in so timing the parts which are brought into action by the key that they shall be engaged one after the other while the key is being depressed, instead of all at the same time. Less force is then required in the blow on the key. For instance, in the constructions that I show (the Remington and Smith Premier machines)

the first opposition which is met on depression of the key is the key-lever-lifting spring. Then when the key has been depressed sufficiently to take up the looseness in the joints between the key-lever and type-bar the type-bar is started on its excursion to the platen, and when the key has been carried down a little farther the universal bar is engaged and the spacing-rocker vibrated. Thus the resistance of the key-lever-lifting spring is first overcome, then the inertia of the type-bar, and, finally, the inertia of the spacing-rocker, the resilience of its retaining-spring and the friction between the rack and the dog caused by the pull of the mainspring. To these parts I add one more, which is engaged last of all—viz., my repulser. Its functions are to take up the surplus energy of the blow on the key, so as to avoid the injurious effects that arise from the dissipation of such energy, and, furthermore, to utilize that energy in starting the key-lever and the spacing-rocker quickly back to their normal positions. In a word, my repulser stores up energy which in machines as now constructed is worse than useless and utilizes such energy to perform useful labor.

In machines provided with reversed escapements my repulser performs a peculiar function, thereby obviating the most serious weakness inherent in reversed escapements—viz., the extreme difficulty of practicing the staccato blow successfully with such escapements. This difficulty is due to the fact that with such escapements the greatest resistance is met with during the first part of the depression of the key instead of during the latter part of the depression, as is the case with ordinary escapements. With ordinary escapements the friction caused between the rack and the dog, with which it engages by the pull of the mainspring, which friction has to be overcome while vibrating the dog across the rack-tooth to feed the carriage, remains constant during the entire depression of the key. This friction constitutes the most serious resistance which has to be overcome to depress the key, especially since in addition to this friction the resilience of the spring which returns the dogs to their normal position must also be overcome and since this latter spring has to be strong enough to itself overcome the friction between the rack and the dogs, as otherwise it could not return the dogs to their normal positions after the release of the key. The stout rocker-frame-returning spring, therefore, has to be stretched more and more the farther the key is depressed, and consequently it is easy and natural for the operator to practice the staccato blow with this kind of escapement. In fact, the combined resistance offered by the friction between the members and by the resilience of the strong rocker-frame-returning spring, offering greater and greater resistance the lower the key is depressed, has much the

same effect on the finger of the operator as did the anvil upon the sledge-hammer in the illustration previously given. With reversed escapements, on the other hand, the resistance caused by the pull of the mainspring is entirely removed as soon as the key has been depressed sufficiently to withdraw the detaining-dog from the rack, since the mainspring is then free to space the carriage, and the friction between the rack and the dog is therefore removed, so that while the operator has to strike a blow of some force to begin the depression of the key by the time the key has been so far depressed that he should begin to lift his finger the detaining-dog will have been withdrawn from the rack, and consequently the resistance offered to the further depression of the key is much less than it was during the early part of the stroke. The result is that the operator, being deprived of the assistance offered by the ordinary escapement in lifting the finger after the stroke, finds it very difficult to lift his finger quickly enough to prevent blurring or double impressions in the print. The difference between the ordinary and reversed escapements in this respect may be readily understood by again referring to the illustration of the hammer and anvil and by supposing that in place of the anvil the hammer be struck upon a bar of iron weak enough so that it will break it in two. In this latter case the hammer, instead of rebounding as it did from the anvil by the force of its own momentum will follow the bar which it has broken, and must be slowly and laboriously lifted by dead-weight to its position for another blow. With reversed escapements the operator, so to speak, breaks through the resistance and then is naturally inclined to follow the key down until the type strikes on the paper, when his blow will be brought to a stop, but abruptly and not until blurring or double impression in the print has occurred, owing to the movement of the paper while the type is in contact with it.

My repulser offers a springy cushion (like that of the anvil) after the resistance of the first part of the blow has been overcome and before any blurring or double impression in the print has occurred. Its new and peculiar function, then, with reversed escapements is to artificially provide a springy resistance which comes into play in time to assist the operator in lifting his finger after the necessary momentum has been imparted to the type-bearer to cause clear printing. It supplies an element which is lacking in reversed escapements unless artificially provided, but which is always present in ordinary escapements.

In some type-writing machines the universal bar is arranged to be depressed by the depression of the keys, while in others it is arranged to be lifted by the depression of the keys. I designate this movement of the uni-

versal bar as the path in which it reciprocates. It is immaterial for the purposes of this invention what the direction of that path may be. For instance, it may be depressed and then lifted, or lifted and then depressed, or otherwise reciprocated. In like manner I designate the movement of the spacing-rocker as the path in which it reciprocates; likewise the path of the key.

By the term "type-bearer" I mean the vehicle of the type. In the drawings the type-bar constitutes this vehicle; but there are various type-bearers known in the art, as, for instance, type-wheels, type-segments, and type-slides. I class all such vehicles under the general designation of "type-bearers." They are all applicable with my invention.

By the normal engagement of the parts in the escapement I mean the engagement of the parts when the machine is at rest. Thus in Fig. 1 the rack and the detaining-dog are shown in their normal engagement. Where in the claims I use the terms "disengaging one of the engaging members in the escapement from the element with which it normally engages" and "disengaging the rack from the dog with which it normally engages," I mean disengaging the parts which are in engagement when the machine is at rest. Thus in Fig. 1 when the detaining-dog has been withdrawn from the rack on the depression of a key the rack is then disengaged from the dog with which it normally engages.

By the term "type-writing machine" I mean to include all typographical machines which are provided with the keyboards for operating to print characters.

What I claim, and desire to secure by Letters Patent, is—

1. In a type-writing machine, the combination of a key, a repulser therefor normally free from the key, a speed-escapement, means for depressing the key and disengaging the normally engaging members in the escapement, means for bringing the said repulser into action while the normally engaging members are disengaged, and means for restoring the key and the escapement to their normal positions, substantially as described.

2. In a type-writing machine, the combination of a key, a repulser therefor normally free from the key, an escapement comprising two members which normally engage together and can be disengaged and reengaged and one of which can be spaced step by step with respect to and under control of the other, means for depressing the key and disengaging the escapement members, means for feeding the spaced member when disengaged, means for bringing the said repulser into action while the normally engaging escapement members are disengaged, and means for restoring the key and the escapement to their normal positions, substantially as described.

3. In a type-writing machine, the combination of a key, a repulser therefor normally

free from the key, an escapement comprising
a rack which can be spaced step by step and
a dog which normally engages therewith and
can be disengaged and reengaged, means for
5 depressing the key and disengaging the dog
from the rack, means for spacing the rack
when disengaged, means for bringing the re-
pulsor into action while the normally engag-
ing dog is disengaged from the rack, and

means for restoring the key and the escape- 10
ment to their normal positions, substantially
as described.

Subscribed by me this 14th day of Novem-
ber, 1891, in New York city, New York.

FREDERIC W. HILLARD.

In presence of—

THOMAS EWING, Jr.,

S. W. BALCH.