

(19) World Intellectual Property Organization  
International Bureau



(43) International Publication Date  
1 November 2001 (01.11.2001)

PCT

(10) International Publication Number  
**WO 01/80751 A1**

(51) International Patent Classification<sup>7</sup>: **A61B 17/58**

S.; 18 Ballantree, Rancho Santa Margarita, CA 92688 (US).  
**VON HOFFMAN, Gerard**; 3 Via Presea, Coto de Caza,  
CA 92679 (US).

(21) International Application Number: PCT/US01/13366

(22) International Filing Date: 26 April 2001 (26.04.2001)

(74) Agent: **ALTMAN, Daniel, E.**; Knobbe, Martens, Olson  
and Bear, LLP, 16th Floor, 620 Newport Center Drive,  
Newport Beach, CA 92660 (US).

(25) Filing Language: English

(26) Publication Language: English

(30) Priority Data:  
09/558,057 26 April 2000 (26.04.2000) US  
09/815,263 22 March 2001 (22.03.2001) US  
09/832,289 10 April 2001 (10.04.2001) US

(81) Designated States (*national*): AE, AG, AL, AM, AT, AT  
(utility model), AU, AZ, BA, BB, BG, BR, BY, BZ, CA,  
CH, CN, CR, CU, CZ, CZ (utility model), DE, DE (utility  
model), DK, DK (utility model), DM, DZ, EE, EE (utility  
model), ES, FI, FI (utility model), GB, GD, GE, GH, GM,  
HR, HU, ID, IL, IN, IS, JP, KE, KG, KP, KR, KZ, LC, LK,  
LR, LS, LT, LU, LV, MA, MD, MG, MK, MN, MW, MX,  
MZ, NO, NZ, PL, PT, RO, RU, SD, SE, SG, SI, SK, SK  
(utility model), SL, TJ, TM, TR, TT, TZ, UA, UG, UZ, VN,  
YU, ZA, ZW.

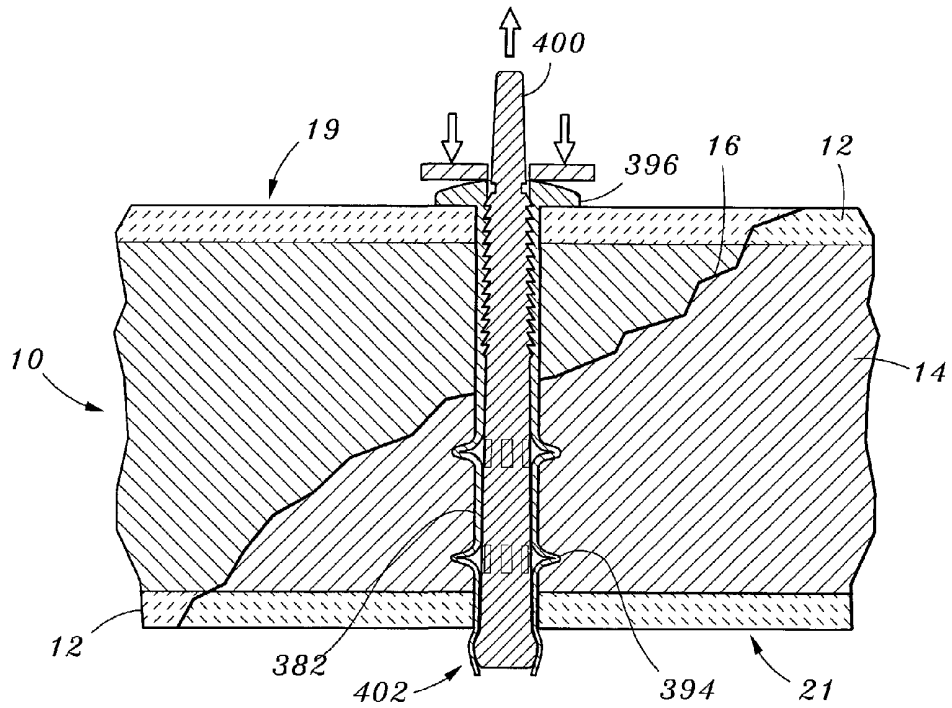
(71) Applicant: **ANCHOR MEDICAL TECHNOLOGIES,  
INC.** [US/US]; 13700 Alton Parkway, Suite 157, Irvine,  
CA 92610 (US).

(84) Designated States (*regional*): ARIPO patent (GH, GM,  
KE, LS, MW, MZ, SD, SL, SZ, TZ, UG, ZW), Eurasian  
patent (AM, AZ, BY, KG, KZ, MD, RU, TJ, TM), European

(72) Inventors: **CACHIA, Victor, V.**; 28334 Paseo Michele,  
San Juan Capistrano, CA 92675 (US). **CULBERT, Brad,**

[Continued on next page]

(54) Title: BONE FIXATION SYSTEM



(57) Abstract: Disclosed is a bone fixation device of the type useful for connecting soft tissue or tendon to bone or for connecting two or more bone fragments together. The device comprises an elongate body (24) having a distal anchor (34) thereon. A proximal anchor (36) is axially movably disposed with respect to the distal anchor, to accommodate different bone dimensions and permit appropriate tensioning of the fixation device.



WO 01/80751 A1



patent (AT, BE, CH, CY, DE, DK, ES, FI, FR, GB, GR, IE, IT, LU, MC, NL, PT, SE, TR), OAPI patent (BF, BJ, CF, CG, CI, CM, GA, GN, GW, ML, MR, NE, SN, TD, TG).

— *before the expiration of the time limit for amending the claims and to be republished in the event of receipt of amendments*

**Published:**

— *with international search report*

*For two-letter codes and other abbreviations, refer to the "Guidance Notes on Codes and Abbreviations" appearing at the beginning of each regular issue of the PCT Gazette.*

## BONE FIXATION SYSTEM

### Background of the Invention

The present invention relates to bone fixation systems and, more particularly, absorbable or nonabsorbable bone fixation pins of the type for fixing soft tissue or tendons to bone or for securing two or more adjacent bone fragments or bones together.

Bones which have been fractured, either by accident or severed by surgical procedure, must be kept together for lengthy periods of time in order to permit the recalcification and bonding of the severed parts. Accordingly, adjoining parts of a severed or fractured bone are typically clamped together or attached to one another by means of a pin or a screw driven through the rejoined parts. Movement of the pertinent part of the body may then be kept at a minimum, such as by application of a cast, brace, splint, or other conventional technique, in order to promote healing and avoid mechanical stresses that may cause the bone parts to separate during bodily activity.

The surgical procedure of attaching two or more parts of a bone with a pin-like device requires an incision into the tissue surrounding the bone and the drilling of a hole through the bone parts to be joined. Due to the significant variation in bone size, configuration, and load requirements, a wide variety of bone fixation devices have been developed in the prior art. In general, the current standard of care relies upon a variety of metal wires, screws, and clamps to stabilize the bone fragments during the healing process. Following a sufficient bone healing period of time, the percutaneous access site or other site may require re-opening to permit removal of the bone fixation device.

Long bone fractures are among the most common encountered in the human skeleton. Many of these fractures and those of small bones and small bone fragments must be treated by internal and external fixation methods in order to achieve good anatomical position, early mobilization, and early and complete rehabilitation of the injured patient.

The internal fixation techniques commonly followed today frequently rely upon the use of Kirschner wires (K-wires), intramedullary pins, wiring, plates, screws, and combinations of the foregoing. The particular device or combination of devices is selected to achieve the best anatomic and functional condition of the traumatized bone with the simplest operative procedure and with a minimal use of foreign-implanted stabilizing material. A variety of alternate bone fixation devices are also known in the art, such as, for example, those disclosed in U.S. Patent No. 4,688,561 to Reese, U.S. Patent No. 4,790,304 to Rosenberg, and U.S. Patent No. 5,370,646 to Reese, et al.

Notwithstanding the common use of the K-wire to achieve shear-force stabilization of bone fractures, K-wire fixation is attended by certain known risks. For example, a second surgical procedure is required to remove the device after healing is complete. Removal is recommended, because otherwise the bone adjacent to an implant becomes vulnerable to stress shielding as a result of the differences in the modulus of elasticity and density between metal and the bone.

In addition, an implanted K-wire may provide a site for a variety of complications ranging from pin-tract infections to abscesses, resistant osteomyelitis, septic arthritis, and infected nonunion.

Another potential complication involving the use of K-wires is in vivo migration. Axial migration of K-wires has been reported to range from 0 mm to 20 mm, which can both increase the difficulty of pin removal as well as inflict trauma to adjacent tissue.

5 As conventionally utilized for bone injuries of the hand and foot, K-wires project through the skin. In addition to the undesirable appearance, percutaneously extending K-wires can be disrupted or cause damage to adjacent structures such as tendons if the K-wire comes into contact with external objects.

Notwithstanding the variety of bone fasteners that have been developed in the prior art, there remains a need for a bone fastener of the type that can accomplish shear-force stabilization with minimal trauma to the surrounding tissue both during installation and following bone healing.

10 In addition, there remains a need for a simple, adjustable bone fixation device which may be utilized to secure soft tissue or tendon to bone.

#### Summary of the Invention

There is provided in accordance with one aspect of the present invention, a bone anchor deployment system. The system comprises a bone anchor deployment device, having a frame, an anchor connector for connection to the proximal end of a bone anchor, and an anchor tensioning surface for resisting proximal movement of an anchor support. At least one bone anchor, having an elongate support, at least one radially expandable anchor on the support, and an elongate pin carried by the support is also provided. The anchor connector and the pin have complimentary surface structures, so that the anchor connector and pin are connectable to each other, and manipulation of the deployment device axially displaces the pin with respect to the support.

20 Preferably, at least two and more preferably a plurality of similar or different sized bone anchoring devices are provided. Each device may be separately packaged in a sterile package. Alternatively, two or more devices may be contained in a dispensing cartridge to permit a plurality of devices to be disposed without reloading the gun. In one embodiment, the support comprises a tubular body axially slidably carried by the pin. Preferably, the anchor connector comprises a snap fit lock for engaging a recess on the pin. The pin may further comprise a break point which releases the proximal end of the pin upon application of a sufficient tension. The bone anchors are preferably made from a bioresorbable material.

30 In accordance with another aspect of the invention, there is provided a bone fixation device. The device comprises an elongate support, having at least one axially compressible anchor thereon. An elongate tapered pin is axially moveably carried by the support. Axial proximal withdrawal of the pin with respect to the support both radially enlarges at least a portion of the support and axially compresses the anchor, thereby causing at least a portion of the anchor to incline radially outwardly from the support. Preferably, the bone fixation device comprises a bioabsorbable material.

35 There is provided in accordance with yet another aspect of the present invention, a fixation pin for fixing bone to bone or other tissue to bone. The fixation pin comprises a body, having a proximal end and a distal end. A distal anchor is on the body. The distal anchor comprises at least a first retention surface on a first axially extending lever arm and a second retention surface on a second axially extending lever arm. Preferably, the first and second retention surfaces are

laterally moveable between a first, implantation crossing profile and a second, larger, deployed crossing profile. The first and second retention structures are preferably biased in the direction of the second crossing profile. In certain embodiments, at least three retention surfaces and at least three lever arms are provided. The fixation pin may be integrally formed from a single piece of metal which may comprise titanium.

5           The fixation pin may further comprise a retention structure on the body, for retaining a proximal anchor. The retention structure may comprise a deviation in the surface of the body, such as an annular ridge, helical thread, or other recess or projection. A proximal anchor is moveably carried by the body.

The fixation pin may additionally comprise at least one breakpoint on the body, for allowing a proximal projection of the body to be snapped off, following tensioning of the proximal anchor.

10           In accordance with still yet another aspect of the present invention, there is provided a fixation pin for bone to bone or other tissue to bone fixation. The fixation pin comprises a tubular body, having a proximal end and a distal end. At least two slots are provided in the tubular body, extending proximally from the distal end to define at least a first and a second axially extending lever arms. A proximally facing retention surface is carried by each lever arm. A retention structure is also provided on the body, for removably carrying a proximal anchor. The first and second retention surfaces  
15 are laterally moveable between an implantation crossing profile and a deployed crossing profile.

The retention structure may comprise a thread on the body, proximal to at least a portion of the lever arms. A proximal anchor is moveably carried by the thread.

In accordance with another aspect of the present invention, there is provided a fixation pin for fixing a first material to bone. The pin comprises an elongate tubular body, having a proximal end and a distal end. A plurality of  
20 deflectable barbs are carried by the distal end. A thread is provided on the tubular body, in-between the proximal end and the distal end, and a break point is provided on the tubular body, proximal to at least a portion of the thread.

The pin may further comprise a proximal anchor, removably retained on the tubular body by the thread. A rotational coupling is provided on the pin, for coupling to a tool. A second rotational coupling is provided on the anchor, to permit rotation of the anchor while resisting rotation of the pin. Each of the barbs may be attached to the tubular body by  
25 an axially extending lever arm.

In accordance with another aspect of the present invention, there is provided a fixation device for securing a first bone fragment to a second bone fragment. The fixation device comprises an elongate pin, having a proximal end and a distal end. At least one radially advanceable anchor is carried by the pin. An actuator, which is axially moveable with respect to the pin is also provided. The device includes at least one retention structure in between the  
30 pin and the actuator, for permitting proximal movement of the pin with respect to the actuator but resisting distal movement of the pin with respect to the actuator. Axial proximal movement of the pin with respect to the actuator causes at least a portion of the anchor to advance along a path which is inclined radially outwardly from the pin in the proximal direction.

The actuator may comprise a tubular body axially slidably carried on the pin. The anchor comprises at least  
35 one axially extending strip, having a free proximal end and a distal end, carried by the pin. The strip is moveable from

an axial orientation to an inclined orientation in response to axial proximal retraction of the pin. In certain embodiments, at least two or four or more axially extending strips are provided.

The device may also comprise a hub carried by the pin. The distal end of the strip is connected to the hub. The hub preferably comprises an annular ring, axially movably carried by the pin. The hub may be fixed with respect to the pin.

The device may also include a first retention structure on the actuator for cooperating with a second retention structure on the pin to retain the device under compression. At least one of the actuator and the pin may comprise a bioabsorbable material, such as poly (L-lactide-co-D, L-lactide).

The distal end of the actuator may have a tapered surface, so that proximal retraction of the pin with respect to the actuator causes the anchor to incline outwardly as it slides along the tapered surface. The proximal end of the anchor may have a complementary tapered surface to slide along the tapered surface on the actuator. The pin may also have a relatively larger diameter near the distal end and a relatively smaller diameter proximally of the distal end.

In accordance with another aspect of the present invention, there is provided a bone fixation device for fixing two or more bone fragments. The fixation device comprises an elongate tubular body, having a proximal end, a distal end and a longitudinal axis. A distal anchor is on the fixation device, moveable from a low profile orientation for distal insertion through a bore in the bone to an inclined orientation to resist axial proximal movement through the bore. An elongate pin is axially moveable within the tubular body and associated with the anchor, such that proximal retraction of the pin with respect to the tubular body advances the distal anchor from the axial orientation to the inclined orientation.

The bone fixation device may also comprise at least one retention structure for retaining the anchor in the inclined orientation. The retention structure may comprise at least one ramped surface that inclines radially inwardly in the proximal direction. Alternatively, the retention structure includes at least one annular ridge. A first retention structure may be on the tubular body, and a second, complimentary retention structure may be provided on the pin.

The device may also comprise a proximal anchor. The distal anchor comprises at least two axially extending strips spaced circumferentially apart around the tubular body.

The tubular body may comprise a first tapered surface and the pin may comprise a second tapered surface such that proximal retraction of the pin with respect to the tubular body causes a radial enlargement of at least a portion of the tubular body.

Further features and advantages of the present invention will become apparent to those of skill in the art in view of the detailed description of preferred embodiments which follows, when considered together with the attached claims and drawings.

#### Brief Description of the Drawings

Figure 1 is a cross-sectional schematic view of a bone fixation device of the present invention positioned within a fractured bone.

Figure 2 is a longitudinal cross-sectional view through the pin body of the present invention.

Figure 3 is a distal end elevational view of the pin body of Figure 2.

Figure 4 is a longitudinal cross-sectional view of the proximal anchor of the bone fixation device.

Figure 5 is a proximal end elevational view of the proximal anchor of the bone fixation device.

5 Figure 6 is a side elevational view of an alternate embodiment of the bone fixation device of the present invention.

Figure 7 is a side elevational view of an alternate embodiment of the pin body in accordance with the present invention.

Figure 8 is a longitudinal cross-sectional view through the pin body of Figure 7.

10 Figure 9 is a distal end elevational view of the pin body of Figure 7.

Figure 10 is an enlarged detail view of the distal end of the device shown in Figure 8.

Figure 11 is a cross-sectional view through a proximal anchor for use with the pin body of Figure 7.

Figure 12 is a proximal end elevational view of the proximal anchor end of Figure 11.

Figure 13 is a side elevational view of a guide wire that may be used with the pin body of Figure 7.

15 Figure 14 is a longitudinal cross-sectional view of the guide wire of Figure 13 and the pin body of Figure 7.

Figure 15 is a side elevational view of an alternate fixation device in accordance with the present invention, in the low profile configuration.

Figure 16 is a side elevational view as in Figure 15, with the fixation device in the implanted (radially enlarged) configuration.

20 Figure 16A is a side elevational cross section through an alternate distal anchor, in the implanted configuration.

Figure 16B is a side elevational fragmentary view of an anchor positioned along the length of the fixation device, shown in the implanted configuration.

Figure 17 is a side elevational view of the pin illustrated in Figure 15.

Figure 18 is a side elevational detail view of the distal end of the pin illustrated in Figure 17.

25 Figure 19 is a side elevational detailed view of the retention structures on the pin illustrated in Figure 17.

Figure 20 is a side elevational view of a distal anchor and hub assembly of the fixation system illustrated in Figure 15.

Figure 21 is an end view of the anchor assembly illustrated in Figure 20.

Figure 22 is a side elevational view of the actuator of the device illustrated in Figure 15.

30 Figure 23 is a cross sectional view taken along the line 23-23 of the actuator illustrated in Figure 22.

Figure 24 is an end elevational view of the actuator illustrated in Figure 22.

Figure 25 is a detail view of a portion of the actuator illustrated in Figure 23.

Figure 26 is an anterior view of the distal tibia and fibula, with fixation devices across medial and lateral malleolar fractures.

Figure 27 is a cross-sectional schematic view of an alternate embodiment bone anchor of the present invention positioned within a bone.

Figure 28 is a view of a bone anchor positioned within a bone as in Figure 27, with the pin proximally withdrawn to set the anchors within the bone.

5 Figure 29 is a partial cross-sectional side elevational view of the bone anchor of Figures 27 and 28.

Figure 30 is a view of the bone anchor as in Figure 29, with the pin proximally withdrawn to radially expand the bone anchors.

Figure 31 is an exploded, perspective view of an alternate fixation device in accordance with the present invention.

10 Figure 32 is a cross-sectional schematic view of the fixation device of Figure 31, positioned within a fractured bone.

Figure 33 is a cross-sectional schematic view as in Figure 32, after the anchors have been set.

Figure 34 is a cross-sectional schematic view as in Figure 33, following removal of the tensioning device and severing the proximal extension of the pin.

15 Figure 35 is a side elevational exploded view of an alternate fixation device in accordance with the present invention.

Figure 36 is a detailed view taken along the line 36-36 in Figure 35.

Figure 37 is an exploded cross-sectional view through an alternate fixation device in accordance with the present invention, with the pin taper exaggerated for illustration purposes only.

20 Figure 38 is an end elevational view taken along the line 38-38 in Figure 37.

Figure 39 is a cross-sectional schematic view of the fixation device of Figure 37, set within a fractured bone.

#### Detailed Description of Preferred Embodiments

25 Although the application of the present invention will be disclosed in connection with the simplified bone fracture of Figure 1, the methods and structures disclosed herein are intended for application in any of a wide variety of bones and fractures, as will be apparent to those of skill in the art in view of the disclosure herein. For example, the bone fixation device of the present invention is applicable in a wide variety of fractures and osteotomies in the hand, such as interphalangeal and metacarpophalangeal arthrodesis, transverse phalangeal and metacarpal fracture fixation, spiral phalangeal and metacarpal fracture fixation, oblique phalangeal and metacarpal fracture fixation, intercondylar phalangeal and metacarpal fracture fixation, phalangeal and metacarpal osteotomy fixation as well as others known in the art. A wide variety of phalangeal and metatarsal osteotomies and fractures of the foot may also be stabilized using the bone fixation device of the present invention. These include, among others, distal metaphyseal osteotomies such as those described by Austin and Reverdin-Laird, base wedge osteotomies, oblique diaphyseal, digital arthrodesis as well as a wide variety of others that will be known to those of skill in the art. Fractures and osteotomies and arthrodesis of the tarsal bones such as the calcaneus and talus may also be treated. Spiked washers can be used, attached to the collar or freely movable

30

35



beneath the collar. The bone fixation device may be used with or without plate(s) or washer(s), all of which can be either permanent, absorbable or comprising both.

Fractures of the fibular and tibial malleoli, pilon fractures and other fractures of the bones of the leg may be fixated and stabilized with the present invention with or without the use of plates, both absorbable or non-absorbable types, and with alternate embodiments of the current invention. One example is the fixation of the medial malleolar avulsion fragment fixation with the radially and axially expanding compression device. Each of the foregoing may be treated in accordance with the present invention, by advancing one of the fixation devices disclosed herein through a first bone component, across the fracture, and into the second bone component to fix the fracture.

The fixation device of the present invention may also be used to attach tissue or structure to the bone, such as in ligament reattachment and other soft tissue attachment procedures. Plates and other implants may also be attached to bone, using either resorbable or nonresorbable fixation devices disclosed herein depending upon the implant and procedure. The fixation device may also be used to attach sutures to the bone, such as in any of a variety of tissue suspension procedures.

For example, peripheral applications for the fixation devices include utilization of the device for fastening soft tissue such as capsule, tendon or ligament to bone. It may also be used to attach a synthetic material such as marlex mesh, to bone or allograft material such as tensor fascia lata, to bone. In the process of doing so, retention of the material to bone may be accomplished with the collar as shown, with an enlarged collar to increase contact surface area, with a collar having a plurality of spikes to enhance the grip on adjacent tissue, or the pin and or collar may be modified to accept a suture or other material for facilitation of this attachment.

Specific examples include attachment of the posterior tibial tendon to the navicular bone in the Kidner operation. Navicular-cuneiform arthrodesis may be performed utilizing the device and concurrent attachment of the tendon may be accomplished. Attachment of the tendon may be accomplished in the absence of arthrodesis by altering the placement of the implant in the adjacent bone.

Ligament or capsule reattachment after rupture, avulsion or detachment, such as in the ankle, shoulder or knee can also be accomplished using the devices disclosed herein.

The fixation devices may be used in combination with semi tubular, one-third tubular and dynamic compression plates, both of metallic and absorbable composition, preferably by modifying the collar to match the opening on the plate. The cannulated design disclosed below can be fashioned to accept an antibiotic impregnated rod for the slow release of medication and/or bone growth or healing agents locally. This may be beneficial for prophylaxis, especially in open wounds, or when osteomyelitis is present and stabilization of fracture fragments is indicated. The central lumen can also be used to accept a titanium or other conductive wire or probe to deliver an electric current or electromagnetic energy to facilitate bone healing.

A kit may be assembled for field use by military or sport medical or paramedical personnel. This kit contains an implanting tool, and a variety of implant device size and types, a skin stapler, bandages, gloves, and basic tools for emergent wound and fracture treatment. Antibiotic rods would be included for wound prophylaxis during transport.

Referring to Figure 1, there is illustrated generally a bone 10, shown in cross-section to reveal an outer cortical bone component 12 and an inner cancellous bone component 14. A fracture 16 is schematically illustrated as running through the bone 10 to at least partially divide the bone into what will for present purposes be considered a proximal component 19 and distal component 21. The fracture 16 is simplified for the purpose of illustrating the application of the present invention. However, as will be understood by those of skill in the art, the fracture 16 may extend through the bone at any of a wide variety of angles and depths. The bone fixation device of the present invention may be useful to stabilize two or more adjacent components of bone as long as each component may be at least partially traversed by the bone fixation device and anchored at opposing sides of the fracture to provide a sufficient degree of stabilization.

A proximal aperture 18 is provided in the proximal component 19 of the bone 10, such as by drilling, as will be discussed. A distal aperture 20 is provided in an opposing portion of bone such as in distal bone component 21 and is connected to the proximal aperture 18 by way of a through hole 22, as is known in the art, in a through hole application. The fixation device may also be useful in certain applications where the distal end of the device resides within the bone.

The bone fixation device 24 is illustrated in Figure 1 in its installed position within the through hole 22. The bone fixation device 24 generally comprises an elongate pin 26 having a proximal end 28, a distal end 30, and an elongate pin body 32 extending therebetween.

The distal end 30 of pin 26 is provided with a distal anchor 34, as will be discussed. A proximal anchor 36 is also provided, such as a radially outwardly extending collar 38 connected to a tubular housing 40 adapted to coaxially receive the pin body 32 therethrough.

The radially interior surface of the tubular housing 40, in the illustrated embodiment, is provided with a plurality of retention structures 42. Retention structures 42 cooperate with corresponding retention structures 44 on the surface of pin body 32 to permit advancement of the proximal anchor 36 in the direction of the distal anchor 34 for properly sizing and tensioning the bone fixation device 24. Retention structures 42 then cooperate with retention structures 44 to provide a resistance to movement of the proximal anchor 36 in the proximal direction relative to pin body 32.

In use, the proximal projection of pin 26 which extends beyond the proximal anchor 36 after tensioning is preferably removed, such as by cutting, to minimize the projection of the bone fixation device 24 from the surface of the bone.

One embodiment of the pin 26, adapted for fixing oblique fractures of the fibula or metatarsal bone(s) is illustrated in Figure 2. The bone fixation device 24 of this embodiment uses a generally cylindrical pin body 32. Although the present invention is disclosed as embodied in a pin body 32 having a generally circular cross section, cross sections such as oval, rectangular, square or tapered to cause radial along with axial bone compression or other configurations may also be used as desired for a particular application.

Pin body 32 generally has an axial length of within the range of from about 5 mm or about 10 mm to about 70 mm in the as-manufactured condition. In one embodiment intended for small bones in the foot, the pin body 32 has an axial length of about 19 mm. The illustrated embodiment shows a solid pin body 32. However, a cannulation may be provided

along the longitudinal axis of the body to allow introduction of the pin over a wire as is understood in the art. Hollow tubular structures may also be used.

5 The retention structures 44 on the surface of pin body 32 in the illustrated embodiment comprise a plurality of annular ramp or ratchet-type structures which permit the proximal anchor 36 to be advanced in a distal direction with respect to pin body 32, but which resist proximal motion of proximal anchor 36 with respect to pin body 32. Any of a variety of ratchet-type structures can be utilized in the present invention. The annular ramped rings illustrated in Figure 2 provide, among other advantages, the ability of the ratchet to function regardless of the rotational orientation of the proximal anchor 36 with respect to the pin body 32. In an embodiment having a noncircular cross section, or having a rotational link such as an axially-extending spline on the pin body 32 for cooperating with a complementary keyway on proximal anchor 36, the retention structures 42 can be provided on less than the entire circumference of the pin body as will be appreciated by those of skill in the art. Thus, ratchet structures can be aligned in an axial strip such as at the bottom of an axially extending channel in the surface of the pin body.

15 A single embodiment of the bone fixation device can be used for fixing fractures in bones having any of a variety of diameters. This is accomplished by providing the retention structures 44 over a predetermined axial working length of the pin body 32. For example, in the illustrated embodiment, the retention structures 44 commence at a proximal limit 46 and extend axially until a distal limit 48. Axially extending the retention zone between limits 46 and 48 will extend the effective range of bone thicknesses which the pin 32 can accommodate. Although the retention structures 44 may alternatively be provided throughout the entire length of the pin body 32, retention structures 44 may not be necessary in the most distal portions of pin body 32 in view of the minimum diameter of bones likely to be fixed.

20 In one embodiment of the invention, the distal limit 48 of retention structures 44 is spaced apart from the distal end 30 of pin body 32 by a distance within the range of from about 4 mm to about 20 mm, and, in embodiments for small bones in the foot, from about 4 mm to about 8 mm. The axial length of the portion of the pin body 32 having retention structures 44 thereon, from proximal limit 46 to distal limit 48, is generally within the range of from about 4mm to about 8mm, and was approximately 6 mm in an embodiment having a pin body length of about 19 mm. Depending upon the anchor design, the zone between proximal limit 46 and distal limit 48 may extend at least about 50%, and in some 25 embodiments in excess of about 75% or even in excess of 90% of the length of the pin body.

In general, the minimum diameter of the pin body 32 is a function of the construction material of the pin and the desired tensile strength for a given application. The maximum diameter is established generally by the desire to minimize the diameter of the through hole 22 while still preserving a sufficient structural integrity of the fixation device 24 for the intended application.

30 The diameter of pin body 32 will generally be in the range of from about 1.5 mm or 1.8 mm for small bones of the foot and hand to as large as 7.0 mm or larger for bones such as the tibia. In one absorbable embodiment of the invention intended for use in the first metatarsal, the pin 24 comprises poly (L, co-D,L-lactide) and has a diameter of about 1.8 mm. Any of a variety of other materials may also be used, as discussed *infra*.

The distal anchor 34 in the illustrated embodiment comprises a plurality of ramped extensions 50 which incline radially outwardly in the proximal direction. Extensions 50 are positioned or compressible radially inwardly for the purpose of advancing the pin 32 into, and, in some applications, through the through hole 22. Extensions 50 preferably exert a radially outwardly directed bias so that they tend to extend radially outwardly from the pin body 32 once the distal anchor 34 has advanced out through the distal aperture 20 in bone 10. Proximal traction on the proximal end 28 of pin body 32 will thereafter tend to cause extensions 50 to seat firmly against the outside surface of distal bone component 21, as illustrated in Figure 1. In accordance with an optional feature which can be included in any of the embodiments herein, the pin body 32 is provided with a central lumen extending axially therethrough (cannulated) for introduction over a guide pin as will be understood by those of skill in the art.

Although any of a variety of alternate designs for distal anchor 34 may be utilized in the context of the present invention, any such distal anchors 34 preferably permit axial distal motion of pin body 32 through the through hole 22, and thereafter resist proximal withdrawal of the pin body 32 from through hole 22. As will be appreciated by those of skill in the art, this feature allows the bone fixation device 24 to be set within a bone through a single proximal percutaneous puncture or incision, without the need to expose the distal component 21 or "backside" of the bone. This can be accomplished by biased anchors which are formed integrally with the pin, or which are attached during manufacturing. Distal anchors may also be hinged to the pin body, and may be deployed by a push or pull wire extending through the pin body if the desired construction material does not permit adequate spring bias.

For a through hole having a diameter of about 2.3 mm, pin bodies 32 having an outside diameter of about 1.8 mm in the areas other than retention structures 44, and a maximum outside diameter of about 2.24 mm in the area of retention structures 44 have been found to be useful. In this embodiment, the maximum outside diameter of the distal anchor 34 was approximately 2.92 mm in the relaxed state. The axial length from the distal tip of distal end 30 to the proximal extent of extensions 50 was about 1.21 mm.

The pin body 32, together with the distal anchor 34 and other components of the present invention can be manufactured in accordance with any of a variety of techniques which are well known in the art, using any of a variety of medical-grade construction materials. For example, the pin body 32 and other components of the present invention can be injection-molded from a variety of medical-grade polymers including high or other density polyethylene, nylon and polypropylene. Distal anchor 34 can be separately formed from the pin body 32 and secured thereto in a post-molding operation, using any of a variety of securing techniques such as solvent bonding, thermal bonding, adhesives, interference fits, pivotable pin and aperture relationships, and others known in the art. Preferably, however, the distal anchor 34 is integrally molded with the pin body 32, if the desired material has appropriate physical properties.

Retention structures 44 can also be integrally molded with the pin body 32. Alternatively, retention structures 44 can be machined or pressed into the pin body 32 in a post-molding operation, or secured using other techniques depending upon the particular design.

A variety of polymers which may be useful for the anchor components of the present invention are identified below. Many of these polymers have been reported to be biodegradable into water-soluble, non-toxic materials which can be eliminated by the body:

- Polycaprolactone
- 5 Poly (L-lactide)
- Poly (DL-lactide)
- Polyglycolide
- Poly (L-Lactide-co-D, L-Lactide)
- 70:30 Poly (L-Lactide-co-D, L-Lactide)
- 10 95:5 Poly (DL-lactide-co-glycolide)
- 90:10 Poly (DL-lactide-co-glycolide)
- 85:15 Poly (DL-lactide-co-glycolide)
- 75:25 Poly (DL-lactide-co-glycolide)
- 50:50 Poly (DL-lactide-co-glycolide)
- 15 90:10 Poly (DL-lactide-co-caprolactone)
- 75:25 Poly (DL-lactide-co-caprolactone)
- 50:50 Poly (DL-lactide-co-caprolactone)
- Polydioxanone
- Polyesteramides
- 20 Copolyoxalates
- Polycarbonates
- Poly (glutamic-co-leucine)

The desirability of any one or a blend of these or other polymers can be determined through routine experimentation by one of skill in the art, taking into account the mechanical requirements, preferred manufacturing techniques, and  
 25 desired reabsorption time. Optimization can be accomplished through routine experimentation in view of the disclosure herein.

Alternatively, the anchor components can be molded, formed or machined from biocompatible metals such as Nitinol, stainless steel, titanium, and others known in the art. In one embodiment, the components of the bone fixation device 24 are injection-molded from a bioabsorbable material, to eliminate the need for a post-healing removal step. One  
 30 suitable bioabsorbable material which appears to exhibit sufficient structural integrity for the purpose of the present invention is poly-p-dioxanone, such as that available from the Ethicon Division of Johnson & Johnson. Poly (L-lactide, or co-DL-lactide) or blends of the two may alternatively be used. As used herein, terms such as bioabsorbable, bioresorbable and biodegradable interchangeably refer to materials which will dissipate in situ, following a sufficient bone healing period of time, leaving acceptable byproducts. All or portions of any of the devices herein, as may be appropriate for the particular  
 35 design, may be made from allograft material, or synthetic bone material as discussed elsewhere herein.

The bioabsorbable implants of this invention can be manufactured in accordance with any of a variety of techniques known in the art, depending upon the particular polymers used, as well as acceptable manufacturing cost and dimensional tolerances as will be appreciated by those of skill in the art in view of the disclosure herein. For example, any of a variety of bioabsorbable polymers, copolymers or polymer mixtures can be molded in a single compression molding cycle, or the surface structures can be machined on the surface of the pin or sleeve after the molding cycle. It is also possible to use the techniques of U.S. Pat. No. 4,743,257, the entire disclosure of which is incorporated herein by reference, to mold absorbable fibers and binding polymers together, to create a fiber-reinforced absorbable anchor.

An oriented or self-reinforced structure for the anchor can also be created during extrusion or injection molding of absorbable polymeric melts through a suitable die or into a suitable mold at high speed and pressure. When cooling occurs, the flow orientation of the melt remains in the solid material as an oriented or self-reinforcing structure. The mold can have the form of the finished anchor component, but it is also possible to manufacture the anchor components of the invention by machining injection-molded or extruded semifinished products. It may be advantageous to make the anchors from melt-molded, solid state drawn or compressed, bioabsorbable polymeric materials, which are described, e.g., in U.S. Pat. Nos. 4,968,317 and 4,898,186, the entire disclosures of which are incorporated herein by way of this reference.

Reinforcing fibers suitable for use in the anchor components of the present invention include ceramic fibers, like bioabsorbable hydroxyapatite or bioactive glass fibers. Such bioabsorbable, ceramic fiber reinforced materials are described, e.g., in published European Patent Application No. 0146398 and in WO/96/21628, the entire disclosures of which are incorporated herein by way of this reference.

As a general feature of the orientation, fiber-reinforcement or self-reinforcement of the anchor components, many of the reinforcing elements are oriented in such a way that they can carry effectively the different external loads (such as tensile, bending and shear loads) that are directed to the anchor as used.

The oriented and/or reinforced anchor materials for many applications have tensile strengths in the range of about 100-2000 MPa, bending strengths in the range of about 100-600 MPa and shear strengths in the range of about 80-400 MPa, optimized for any particular design and application. Additionally, they are relatively stiff and tough. These mechanical properties may be superior to those of non-reinforced or non-oriented absorbable polymers, which often show strengths between about 40 and 100 MPa and are additionally may be flexible or brittle. See, e.g., S. Vainionpaa, P. Rokkanen and P. Tormnld, "Surgical Applications of Biodegradable Polymers in Human Tissues", Progr. Polym. Sci., Vol. 14, (1989) at 679-716, the full disclosure of which is incorporated herein by way of this reference.

The anchor components of the invention (or a bioabsorbable polymeric coating layer on part or all of the anchor surface), may contain one or more bioactive substances, such as antibiotics, chemotherapeutic substances, angiogenic growth factors, substances for accelerating the healing of the wound, growth hormones, antithrombogenic agents, bone growth accelerators or agents, and the like. Such bioactive implants may be desirable because they contribute to the healing of the injury in addition to providing mechanical support.

In addition, the anchor components may be provided with any of a variety of structural modifications to accomplish various objectives, such as osteoincorporation, or more rapid or uniform absorption into the body. For example, osteoincorporation may be enhanced by providing a micropitted or otherwise textured surface on the anchor components. Alternatively, capillary pathways may be provided throughout the pin and collar, such as by manufacturing the anchor components from an open cell foam material, which produces tortuous pathways through the device. This construction increases the surface area of the device which is exposed to body fluids, thereby generally increasing the absorption rate. Capillary pathways may alternatively be provided by laser drilling or other technique, which will be understood by those of skill in the art in view of the disclosure herein. In general, the extent to which the anchor can be permeated by capillary pathways or open cell foam passageways may be determined by balancing the desired structural integrity of the device with the desired reabsorption time, taking into account the particular strength and absorption characteristics of the desired polymer.

One open cell bioabsorbable material is described in U.S. Patent No. 6,005,161 as a poly(hydroxy) acid in the form of an interconnecting, open-cell meshwork which duplicates the architecture of human cancellous bone from the iliac crest and possesses physical property (strength) values in excess of those demonstrated by human (mammalian) iliac crest cancellous bone. The gross structure is said to maintain physical property values at least equal to those of human, iliac crest, cancellous bone for a minimum of 90 days following implantation. The disclosure of U.S. Patent No. 6,005,161 is incorporated by reference in its entirety herein.

The anchors of the present invention may be sterilized by any of the well known sterilization techniques, depending on the type of material. Suitable sterilization techniques include heat sterilization, radiation sterilization, such as cobalt 60 irradiation or electron beams, ethylene oxide sterilization, and the like.

In the embodiment illustrated in Figure 4, the proximal anchor 36 comprises a collar 38 for contacting the proximal bone component 19. Collar 38 preferably comprises a radially-outwardly extending annular flange to optimize contact with the proximal bone component 19. Alternatively, proximal collar 38 may comprise one or more radially-outwardly extending stops, a frusto-conical plug, or other structures which stop the distal progress of proximal anchor 36 with respect to the through hole 22 or blind hole, depending upon the application.

The pin body 32 cooperates with a proximal anchor 36 to accomplish the fixation function of the present invention. Proximal anchor 36 is preferably axially movably carried by the pin body 32 throughout a sufficient axial range of motion to accommodate a variety of bone diameters.

Collar 38 is axially movably disposed with respect to pin body 32 such as by connection to a tubular housing 40. Tubular housing 40 is concentrically positioned on pin body 32, and is provided on its interior surface with at least one, and preferably a plurality, of retention structures 42. Retention structures 42 are configured to cooperate with the complementary retention structures 44 on the pin body 32 to permit axial distal advancement of collar 38 with respect to pin body 32, but resist proximal motion of collar 38 with respect to pin body 32, as has been discussed.

In one embodiment of the present invention, the minimum interior diameter of the tubular housing 40 is about 2.00 mm. The maximum interior diameter of the tubular housing 40, at the radial outwardmost bottom of the annular

recesses adapted to cooperate with annular ridges 44 on pin body 32, is about 2.17 mm. The outside diameter of the collar 38 is about 2.70 mm, and the thickness in the axial direction of annular collar 38 is about 0.20 mm.

5 The retention structures 42 may comprise any of a variety of complementary surface structures for cooperating with the corresponding structures 44 on the pin 32, as is discussed elsewhere herein. In the illustrated embodiment, the retention structures are in the form of a plurality of annular rings or helical threads, which extend axially throughout the length of the tubular housing 40. The retention structure 42 may alternatively comprise a single thread, ridge or groove or a plurality of structures which extend only part way (e.g., at least about 10% or 25% or more) along the length of the tubular housing 40. Retention force may be optimized by providing threads or other structures along a substantial portion, e.g., throughout at least 75% or 80% of the axial length of the tubular housing 40.

10 The overall length of the tubular housing 40 may be maximized with respect to the depth of the target borehole for a particular application. For example, in a device intended to fix bones having a diameter within the range of from about 15-20 mm, the axial length of the tubular body 40 is preferably at least about 8 mm or 10 mm, and, more preferably, at least about 12 mm or 14 mm. In this manner, the axial length of the zone of retention structures 42 is maximized, thereby increasing the tensile strength of the implanted device. The proximal anchor 36 can be readily constructed using other dimensions and configurations while still accomplishing the desired function, as will be apparent to those of skill in the art in view of the disclosure herein.

In use, a bone is first identified having a fracture which is fixable by a pin-type fixation device. The clinician assesses the bone, selects a bone drill and drills a through hole 22 in accordance with conventional techniques.

20 A bone fixation device 24 having an axial length and outside diameter suitable for the through hole 22 is selected. The distal end 30 of the bone fixation device 24 is percutaneously or otherwise advanced towards the bone, and subsequently advanced through the through hole 22 until distal anchor 34 exits the distal aperture 20. The proximal anchor 36 may be positioned on the bone fixation device 24 prior to positioning of the pin body 32 in the through hole 22, or following placement of the pin body 32 within through hole 22.

25 Proximal traction is applied to the proximal end 28 of pin body 32, to seat the distal anchor 34. While proximal traction is applied to the proximal end 28 of pin body 32, such as by conventional hemostats or a calibrated loading device, the proximal anchor 36 is advanced distally until the anchor 36 fits snugly against the proximal component 19 of the bone. Appropriate tensioning of the bone fixation device 24 is accomplished by tactile feedback or through the use of a calibration device for applying a predetermined load on implantation.

30 Following appropriate tensioning of the proximal anchor 36, the proximal end 28 of the pin body 32 may be cut off and removed. Pin body 32 may be cut using conventional bone forceps which are routinely available in the clinical setting. Alternatively, a pin may be selected such that it is sized to fit the treatment site such that following tension no proximal extension remains.

Following trimming the proximal end 28 of pin 26, the access site may be closed and dressed in accordance with conventional wound closure techniques.



Preferably, the clinician will have access to an array of bone fixation devices 24, having different diameters and axial lengths. These may be packaged one or more per package in sterile envelopes or peelable pouches, or in dispensing cartridges which may each hold a plurality of devices 24. Upon encountering a bone for which the use of a fixation device is deemed appropriate, the clinician will assess the dimensions and load requirements of the bone, and select a bone  
5 fixation device from the array which meets the desired specifications.

Referring to Figure 6, there is disclosed an alternate embodiment of the fixation pin. The fixation pin 26 illustrated in Figure 6 may be identical to the embodiments previously discussed, except with respect to the proximal anchor 52. Proximal anchor 52 comprises a radially outwardly extending annular collar 54 or other structure for resisting motion of the proximal anchor 52 in a distal direction through the aperture in the bone. Collar 54 is connected to a  
10 proximal portion of the tubular housing 56, analogous to housing 40 previously discussed. Tubular housing 56 is adapted to receive the pin body 32 therethrough.

The radially inwardly facing surface of tubular housing 56 is provided with a plurality of retention structures 58. In this embodiment, retention structures 58 comprise a plurality of recesses or grooves which extend radially outwardly into the tubular housing 56. Retention structures 58 are adapted to cooperate with corresponding retention structure 60  
15 secured to or integral with the pin 32. Retention structure 60 in this embodiment comprise a plurality of radially outwardly extending annular rings or threads, which are adapted to be received within the corresponding retention structures 58. In this embodiment, the proximal anchor 52 is unable to move in an axial direction with respect to pin 32 unless sufficient axial force is applied to plastically-deform the retention structures 58 and/or retention structures 60 so that the tubular housing 56 snaps, ridge by ridge, in the direction of the axial force. The precise amount of axial force necessary to  
20 overcome the resistance to motion of proximal anchor 52 with respect to pin 32 can be optimized through appropriate tolerancing of the corresponding retention structures, together with the selection of materials for the proximal anchor 52 and/or pin 32. Preferably, the tolerances and construction details of the corresponding retention structures 58 and 60 are optimized so that the proximal anchor 52 may be advanced distally over the pin 32 using manual force or an installation tool, and the proximal anchor 52 will have a sufficient retention force to resist movement of the bone fragments under  
25 anticipated use conditions.

Referring to Figures 7-14, there is illustrated an alternate embodiment of the fixation device of the present invention. This embodiment is optimized for construction from a metal, such as titanium or titanium alloy, although other materials including those disclosed elsewhere herein may be utilized for the present embodiment. Referring to Figures 7 and 8, the fixation device includes a body 32 which is in the form of a pin 26 extending between a proximal end 28 and a  
30 distal end 30. The distal end 30 includes a plurality of friction enhancing or interference fit structures such as ramped extensions or barbs 50, for engaging the distal cortical bone or other surface or interior cancellous bone as has been described.

Although the illustrated embodiment includes four barbs 50, oriented at 90° with respect to each other, anywhere from one to about twelve or more barbs 50 may be utilized as will be apparent to those of skill in the art in view  
35 of the disclosure herein. The barbs 50 may be radially symmetrically distributed about the longitudinal axis of the pin 26.

Each barb 50 is provided with a transverse engagement surface 21, for contacting the distal surface of the cortical bone or other structure or surface against which the barb 50 is to anchor. Transverse engagement surfaces 21 may lie on a plane which is transverse to the longitudinal axis of the pin 26, or may be inclined with respect to the longitudinal axis of the pin 26.

5 Each of the transverse engagement surfaces 21 in the illustrated embodiment lies on a common plane which is transverse to the longitudinal axis of the pin 26. Two or more planes containing engagement surfaces 21 may alternatively be provided. The transverse engagement surfaces 21 may also lie on one or more planes which are non-normal to the longitudinal axis of pin 26. For example, the plane of a plurality of transverse engagement surfaces 21 may be inclined at an angle within the range of from about 35° or 45° to about 90° with respect to the longitudinal axis of the pin 26. The  
10 plane of the transverse engagement surface may thus be selected to take into account the angle of the distal surface of the bone through which the pin may be positioned, as may be desired in certain clinical applications.

*In order to facilitate the radially inward compression of the barbs 50 during the implantation process, followed by radially outward movement of the barbs 50 to engage the distal bone surface, each barb 50 in the illustrated embodiment is carried by a flexible or hinged lever arm 23. Lever arms 23 may be formed by creating a plurality of axial slots 15 in the  
15 sidewall of the pin 26. The axial slots 15 cooperate with a central lumen 11 to isolate each barb 50 on a unique lever arm 23. The axial length of the axial slots 15 may be varied, depending upon the desired length over which flexing is desirably distributed, the desired range of lateral motion, and may vary depending upon the desired construction material. For a relatively rigid material such as titanium, axial lengths of the axial slot 15 in excess of about 0.1 inches and preferably in excess of about 0.2 inches are utilized on a pin 26 having an outside diameter of about 0.1 inches and a length of about  
20 1.25 inches. Axial slots 15 will generally extend within a range of from about 5% to about 90%, and often within about 10% to about 30% of the overall length of the pin 26.*

The circumferential width of the slots 15 at the distal end 30 is selected to cooperate with the dimensions of the barbs 50 to permit radial inward deflection of each of the barbs 50 so that the pin 26 may be press fit through a predrilled hole having an inside diameter approximately equal to the outside diameter of the pin 26 just proximal to the transverse  
25 engagement surfaces 21. For this purpose, each of the slots 15 tapers in circumferential direction width from a relatively larger dimension at the distal end 30 to a relatively smaller dimension at the proximal limit of the axial slot 15. See Figure 7. In the illustrated embodiment, each slot 15 has a width of about 0.20 inches at the proximal end and a width of about 0.035 inches at the distal end in the unstressed orientation. The width of the slot 15 may taper continuously throughout its length, or, as in the illustrated embodiment, is substantially constant for a proximal section and tapered over a distal  
30 section of the slot 15. The wall thickness of the lever arm 23 may also be tapered to increase the diameter of the central lumen 11 in the distal direction. This will allow a lower compressed crossing profile before the inside surfaces of the lever arms bottom out against each other.

The pin 26 is additionally provided with a plurality of retention structures 44 as has been discussed. Retention structures 44 are spaced apart axially along the pin 26 between a proximal limit 46 and a distal limit 48. The axial  
35 distance between proximal limit 46 and distal limit 48 is related to the desired axial travel of the proximal anchor 36, and

thus the range of functional sizes of the pin. In one embodiment of the pin 26, the retention structures 44 comprise a plurality of threads, adapted to cooperate with the complimentary retention structures 42 on the proximal anchor 36, which may be a complimentary plurality of threads. In this embodiment, the proximal anchor 36 may be distally advanced along the pin 26 by rotation of the proximal anchor 36 with respect to the pin 26. Proximal anchor 36 may advantageously  
5 be removed from the pin 26 by reverse rotation, such as to permit removal of the pin 26 from the patient. For this purpose, collar 38 is preferably provided with a gripping configuration or structure to permit a removal tool to rotate collar 38 with respect to the pin 26. Any of a variety of gripping surfaces may be provided, such as one or more slots, flats, bores, or the like. In the illustrated embodiment, the collar 38 is provided with a polygonal, and in particular, a hexagonal circumference, as seen in Figure 12.

10 The proximal end 28 of the pin 26 is similarly provided with a structure 29 for permitting rotational engagement with an installation or a removal tool. Rotational engagement may be accomplished using any of a variety of shapes or configurations, as will be apparent to those of skill in the art. One convenient structure is to provide the proximal end 26 with one or more flat side walls, for rotationally engaging a complimentary structure on the corresponding tool. As illustrated in Figure 9, the proximal end 26 may be provided with a structure 29 having a square cross-section.  
15 Alternatively, the exterior cross-section through proximal end 28 may be any of a variety of configurations to permit rotational coupling, such as triangular, hexagonal, or other polygons, or one or more axially extending flat sides or channels on an otherwise round body.

The foregoing structures enable the use of an installation and/or deployment tool having a concentric core within a sleeve configuration in which a first component (e.g. a sleeve) engages the proximal anchor 36 and a second component  
20 (e.g. a core) engages the proximal rotational engagement structure 29 of pin 26. The first component may be rotated with respect to the second component, so that the proximal anchor 36 may be rotated onto or off of the retention structures 44 on pin 26. In a modified arrangement, a first tool (e.g., a pair of pliers or a wrench) may be used to engage the proximal anchor 36 and a second tool (e.g., a pair of pliers or a wrench) may be used to engage the proximal rotational engagement structure 29 of pin 26. In such an arrangement, the first tool may be rotated with respect to the second tool (or vice  
25 versa), so that the proximal anchor 36 may be rotated onto or off the retention structures 44 on the pin 26.

Alternatively, the retention structures 42 on the proximal anchor 36 may be toleranced to permit distal axial advancement onto the pin 26, such as by elastic deformation, but require rotation with respect to the pin 26 in order to remove the proximal anchor 36 from the pin 26.

Any of a variety of alternative retention structures may be configured, to permit removal of the proximal anchor  
30 36 such as following implantation and a bone healing period of time. For example, the retention structures 44 such as threads on the pin 26 may be provided with a plurality of axially extending flats or interruptions, which correspond with a plurality of axial flats on the retention structures 42 of proximal anchor 36. This configuration enables a partial rotation (e.g. 90°) of the proximal anchor 36 with respect to the pin 26, to disengage the corresponding retention structures and permit axial withdrawal of the proximal anchor 36 from the pin 26. One or both of the retention structures 44 and 42 may  
35 comprise a helical thread or one or more circumferentially extending ridges or grooves. In a threaded embodiment, the

thread may have either a fine pitch or a course pitch. A fine pitch may be selected where a number of rotations of proximal anchor 36 is desired to produce a relatively small axial travel of the anchor 36 with respect to the pin 26. In this configuration, relatively high compressive force may be achieved between the proximal anchor 36 and the distal anchor 34. This configuration will also enable a relatively high resistance to inadvertent reverse rotation of the proximal anchor 36.

5 Alternatively, a relatively course pitch thread such as might be found on a luer connector may be desired for a quick twist connection. In this configuration, a relatively low number of rotations or partial rotation of the proximal anchor 36 will provide a significant axial travel with respect to the pin 26. This configuration may enhance the tactile feedback with respect to the degree of compression placed upon the bone. The thread pitch or other characteristics of the corresponding retention structures can be optimized through routine experimentation by those of skill in art in view of the disclosure

10 herein, taking into account the desired clinical performance.

Referring to Figure 7, at least a first break point 31 may be provided to facilitate breaking the proximal portion of the pin 26 which projects proximally of the collar 38 following tensioning of the fixation system. Break point 31 in the illustrated embodiment comprises an annular recess or groove, which provides a designed failure point if lateral force is applied to the proximal end 28 while the remainder of the attachment system is relatively securely fixed. At least a second

15 break point 33 may also be provided, depending upon the axial range of travel of the proximal anchor 36 with respect to the pin 26.

In one embodiment having two or more break points 31, 33, the distal break point 31 is provided with one or more perforations or a deeper recess than the proximal break point 33. In this manner, the distal break point 31 will preferentially fail before the proximal break point 33 in response to lateral pressure on the proximal end 28. This will

20 ensure the minimum projection of the pin 26 beyond the collar 38 following deployment and severing of the proximal end 28 as will be appreciated in view of the disclosure herein.

Proximal projection of the proximal end 28 from the proximal anchor 36 following implantation and breaking at a breakpoint 31 may additionally be minimized or eliminated by allowing the breakpoint 31 or 33 to break off within the proximal anchor 36. Referring to Figure 11, the retention structure 42 may terminate at a point 61 distal to a proximal

25 surface 63 on the anchor 36. An inclined or tapered annular surface 65 increases the inside diameter of the central aperture through proximal anchor 36, in the proximal direction. After the proximal anchor 36 has been distally advanced over a pin 26, such that a breakpoint 31 is positioned between the proximal limit 61 and the proximal surface 63, lateral pressure on the proximal end 28 of pin 26 will allow the breakpoint 31 to break within the area of the inclined surface 65. In this manner, the proximal end of the pin 26 following breaking resides at or distally of the proximal surface 63, thus

30 minimizing the profile of the device and potential tissue irritation.

For any of the (axially deployable) embodiments disclosed above, installation can be simplified through the use of an installation tool. The installation tool may comprise a pistol grip or plier-type grip so that the clinician can position the tool at the proximal extension of pin 32 and through one or more contractions with the hand, the proximal anchor 36, 52 and distal anchor 34 can be drawn together to appropriately tension against the bone fragments. The use of a

35 precalibrated tool can permit the application of a predetermined tension in a uniform manner from pin to pin.

Calibration of the installation device to set a predetermined load on the pin can be accomplished through any of a variety of means which will be understood to those of skill in the art. For example, the pin 32 may be provided with one or more score lines or transverse bores or other modifications which limit the tensile strength of the part at one or more predetermined locations. In this manner, axial tension applied to the proximal end 28 with respect to the collar 54 will  
5 apply a predetermined load to the bone before the pin 32 will separate at the score line. Alternatively, internal structures within the installation tool can be provided to apply tension up to a predetermined limit and then release tension from the distal end of the tool.

Figures 13 illustrates a locking guide wire 150 that may be used with the fixation device described above. The guide wire has a distal end 152 and a proximal end 154. The illustrated guide wire 150 comprises a locking portion 156  
10 that is located at the distal end 152 of the guide wire 150 and an elongated portion 158 that preferably extends from the distal portion 156 to the proximal end 154 of the guide wire 150. The diameter D1 of the elongated portion 158 is generally smaller than the diameter D2 of the distal portion 154. The guide wire 150 can be made from stainless steel, titanium, or any other suitable material. Preferably, in all metal systems, the guidewire 150 and locking portion 156 are made from the same material as the remainder of the fixation device to prevent cathodic reactions.

The locking portion 156 on guidewire 150 can take any of a variety of forms, and accomplish the intended  
15 function as will be apparent to those of skill in the art in view of the disclosure herein. For example, a generally cylindrical locking structure, as illustrated, may be used. Alternatively, any of a variety of other configurations in which the cross section is greater than the cross section of the proximal portion 158 may be used. Conical, spherical, or other shapes may be utilized, depending upon the degree of compression desired and the manner in which the locking portion 156 is designed  
20 to interfit with the distal end 30 of the pin.

The guide wire 150 is configured such that its proximal end can be threaded through the lumen 11 of the pin 26. With reference to Figure 8, the lumen 11 preferably comprises a first portion 160 and a second portion 162. The first  
25 portion 160 is generally located at the distal end 30 within the region of the lever arms of the pin 26. The second portion 162 preferably extends from the first portion 160 to the proximal end 28 of the pin 26. The inside diameter of the first portion 160 is generally larger than the diameter of the second portion 162. As such, the junction between the first portion 160 and the second portion 162 forms a transverse annular engagement surface 164, which lies transverse to the longitudinal axis of the pin 26.

As mentioned above, the guide wire 150 is configured such that its proximal end can be threaded through the  
30 lumen 11 of the pin 26. As such, the diameter D1 of the elongated portion 158 is less than the diameter of the second portion 162 of the lumen 11. In contrast, the diameter D2 of distal portion 156 preferably is slightly smaller than equal to or larger than the diameter of the first portion 160 and larger than the diameter of the second portion 162. This arrangement allows the distal portion 156 to be retracted proximally into the first portion 160 but prevents the distal portion 156 from passing proximally through the pin 26.

In addition, any of a variety of friction enhancing surfaces or surface structures may be provided, to resist distal  
35 migration of the locking guidewire 150, post deployment. For example, any of a variety of radially inwardly or radially

outwardly directed surface structures may be provided along the length of the locking guidewire 150, to cooperate with a corresponding surface structure on the inside surface of the lumen 11, to removably retain the locking guidewire 150 therein. In one embodiment, a cylindrical groove is provided on the inside surface of the lumen 11 to cooperate with a radially outwardly extending annular flange or ridge on the outside diameter of the locking guidewire 150. The complementary surface structures may be toleranced such that the locking guidewire or guide pin may be proximally retracted into the lumen 11 to engage the locking structure, but the locking structure provides a sufficient resistance to distal migration of the locking guidewire 150 such that it is unlikely or impossible to become disengaged under normal use.

In use, after the clinician assesses the bone, selects a bone drill and drills a through hole 22, the distal end 152 of the guide wire 150 and the distal end 30 of the pin 26 are advanced through the through hole until the distal portion 156 and the barbs 50 exit the distal aperture 20. The proximal anchor 36 may be positioned on the bone fixation device 24 prior to positioning of the pin body 32 in the through hole 22, or following placement of the pin body 32 within through hole 22.

The guide wire 150 is preferably thereafter retracted until the distal portion 156 enters, at least partially, the first portion 160 of the pin 26 (see Figure 14). The proximal anchor 36 can then be rotated or otherwise distally advanced with respect to the pin body 26 so as to seat the distal anchor 34 snugly against the distal component 21 of the bone. As such, at least a part of the distal portion 156 of the guide wire 150 becomes locked within the first portion 150 of the pin 26. This prevents the barbs 50 and lever arms 24 from being compressed radially inward and ensures that the barbs 50 remain seated snugly against the distal component 21 of the bone.

Following appropriate tensioning of the proximal anchor 36, the proximal end 28 of the pin body 32 and the proximal end 154 of the guide wire 150 are preferably cut off or otherwise removed. These components may be cut using conventional bone forceps which are routinely available in the clinical setting, or snapped off using designed break points as has been discussed.

Figure 15 shows a bone fixation device 200, which may be used either in a through hole application such as that illustrated in Figure 1, or in a blind hole as in Figure 26 in which the distal anchor is deployed within cancellous bone. The fixation device 200 has a distal portion 215 and a proximal portion 220. In general, as a component of the proximal portion 220 of the device is axially moved, an anchor component on the distal portion 215 of the device advances away from the longitudinal axis of the device to engage cancellous bone.

As with other embodiment disclosed herein, the bone fixation device 200 may be used alone, in multiples such as two or three or four or more per fixation, and/or together with plates, intramedullary nails, or other support structures. The bone fixation device 200 may also be used in any of a variety of locations on the body, as has been discussed previously. These include, for example, femur neck fractures, medial and lateral malleolar fractures, condylar fractures, epicondylar fractures, and colles fractures (distal radius and ulnar).

The bone fixation device generally comprises an elongate pin 205 having a proximal end 222, a distal end 224 and an actuator 210. As the actuator 210 is advanced distally with respect to the pin 205, the distal portion of

the pin 205 expands, engaging the bone. Figure 16 shows the device 200 in a deployed mode, such that the distal portion of the pin 205 is in an expanded state.

The pin 205 can have any of a variety of dimensions, depending upon the intended use environment. In one embodiment, useful, for example, in a malleolar fracture, the pin has an overall length of about 2.5 inches and a diameter of about 0.136 inches between the retention structures 240 and the distal end 224. See Figure 17. The outside diameter of the pin 205 proximally of the retention structures 240 may be somewhat smaller, and, in the illustrated embodiment, the outside diameter is about 0.130 inches. The axial length of the retention zone which includes retention structures 240 can also be varied widely, depending upon the range of travel desired for the proximal anchor as has been discussed in connection with previous embodiments. In the illustrated embodiment, the axial length of the retention structure 240 zone is about 0.240 inches.

The distal end 224 of pin 205 comprises a transverse surface 225 such as an annular flange formed by a radially enlarged head 227. See Figure 18. The head 227 is provided with a frusto conical tapered surface 229, to facilitate introduction of the device into and advancement through a bore in a bone. The transverse surface 225 is provided to retain a hub 235, as will be discussed below. In one embodiment, the distal end of the pin 224 immediately proximal to the transverse surface 225 has an outside diameter of about 0.144 inches, and the adjacent portion of the head 227 has an outside diameter of about 0.172 inches to provide a transverse surface 225 having a radial dimension of about 0.014 inches. The pin 205 may be cannulated as has been previously discussed.

In the illustrated embodiment, the distal tapered surface 229 is substantially smooth, to permit insertion into a predrilled borehole. Alternatively, the distal surface 229 may include a drill tip, such as one or more sharpened edges to enable introduction of the fixation device 200 into a bone without the requirement of predrilling a borehole. In a self drilling embodiment of the bone fixation device 200, the proximal end 222 of the pin 205 may be attached directly to a drill using a conventional chuck connection, or may be provided with a slot, or a hexagonal cross section or other rotational interlock structure for coupling to a rotational driving device.

Figure 19 shows a detailed view of the retention structure 240 on the pin for restricting movement between the actuator 210 and the pin 205. The retention structure may comprise a plurality of recesses, grooves, or serrations, including helical threads, which extend radially inwardly or outwardly often in an annular configuration. The retention structure 240 may include one or more ramped surfaces that incline radially inwardly in the proximal direction. These structures, and the complementary structures which may be used on the actuator 210 have been disclosed elsewhere herein. In the illustrated embodiment, the retention structure 240 comprises a plurality of annular ramped rings, each ramp having a length in the axial direction of about 0.016 inches. The ramped surfaces incline radially outwardly in the distal direction, to facilitate distal advancement of the proximal anchor with respect to the pin 205, and resist proximal motion of the proximal anchor with respect to the pin 205, as is discussed elsewhere herein.

A radially advanceable anchor 230 (Figures 20 and 21) is provided at the distal end of the pin. The anchor 230 is shown as having four axially extending strips or tines 231, 232, 233, 234 carried by the pin; however, the

anchor 230 may have one or two or a plurality of axially extending strips. The strips 231-234 are moveable from an axial orientation (for insertion) to an inclined orientation in response to an axial proximal retraction of the pin relative to the actuator 210. The proximal end of the strips 231-234 are free, to permit radial enlargement. The distal end of the strips 231-234 are attached to the distal end of the pin 205 either directly (e.g. Fig. 16A), or indirectly such as in  
5 Figures 15-16. The collapsed anchor 230 may be provided with an outside diameter that is less than the outside diameter of the actuator tube 210 and the head 227 of the pin 205, to facilitate insertion into the hole without placing stress on the anchor 230.

*In the illustrated embodiment, the anchor 230 is formed as a separate component of the fixation system.* This enables the pin 205 and the actuator 210 to be conveniently manufactured from a bioabsorbable material, while  
10 the anchor assembly 230 may be made from any of a variety of biocompatible metals such as stainless steel, titanium or nickel titanium alloys such as nitinol. This variety of a hybrid absorbable-nonabsorbable fixation device takes advantage of the strength and flexibility of nitinol or other metal in the area of the strips 231-234, yet leaves only a minimal amount of metal within the bone following dissolution of the bioabsorbable component. In addition, the long term indwelling component (the metal anchor) does not span the fracture.

15 Although sometimes referred to herein as "strips" the moveable anchor components 231-234 may take any of a variety of shapes, depending upon the desired construction materials, manufacturing technique and performance. In the illustrated embodiment, the anchor 230 may be formed from a piece of tubing stock, such as nitinol tubing, by laser etching or other cutting technique. The anchor 230 has an outside diameter of about 0.172 inches, and an axial length of about 0.394 inches. Each of the strips 231-234 has a width in the circumferential direction of  
20 approximately 0.08 inches and a radial direction wall thickness of no more than about 0.014 inches. However, any of a variety of dimensions may be utilized, as will be apparent to those of skill in the art in view of the disclosure herein. In addition, more or fewer than four axially extending tines 231-234 may be readily provided.

The strips 231-234 may alternatively be formed from a round cross section material such as wire, or other separate component which is assembled or fabricated into a finished multi strip anchor 230.

25 In the illustrated anchor 230, the proximal end 237 of each strip is provided with a ramped surface 239. The ramped surface causes the radial thickness of the strip to decrease in the proximal direction. This ramped surface 239 cooperates with a complementary ramped surface on the actuator, discussed elsewhere herein, to facilitate radial outward advancement of the anchor in response to proximal retraction of the pin 205 with respect to the actuator 210.

30 The ramped surface 239 on each tine or strip also acts as a leading cutting edge to permit each tine to cut into cancellous bone as it advances along a path which will normally be inclined radially outwardly in the proximal direction, in response to proximal retraction of the pin with respect to the actuator. Placing the ramped surface on the radially inwardly facing surface of the tine may allow the tine to seek a maximum angle with respect to the longitudinal axis of the pin, following deployment. This anchor construction thus enables each of the tines to create  
35 its own path through the bone such that the cross section of the tine substantially fills the cross section of the path



which it creates. The length of the path along the axis of the tine is generally at least about two times, and in certain embodiments is at least as much as three times or five or more times the average cross section of the tine. The path may be substantially linear or curved, such as slightly concave outwardly from the axis of the pin.

5 The pin 205 may comprise two or more anchors 230 along its length, each anchor comprising one or two or more (e.g., 4) axial strips. The anchors are each moveable from an axial orientation for distal insertion through a bore in the bone to an inclined orientation to resist proximal axial movement through the bone. In certain embodiments, the anchor 230 and pin 205 are provided with a mechanical interlock such as a projection and slot or other complementary surface structures to prevent rotation of the anchor 230 with respect to the pin 205.

10 Referring to Figure 16B, there is illustrated an in-line or intermediate anchor 230, which may be used in combination with a distal anchor such as that illustrated in Figure 220, to provide two cancellous bone anchors spaced axially apart along the fixation device. In one embodiment, each of the two cancellous bone anchors is provided with four axially extending anchor strips 231-234. In the embodiment of Figure 16B, each of the anchor strips 232 and 234 may be provided with an inclined surface 239 as has been discussed, to cooperate with a complementary inclined surface on the actuator 210. Actuator 210 may be provided with an opening 242 corresponding to each strip 232, to permit functioning of the anchor as will be understood by reference to Figure 16B. In a hybrid absorbable-nonabsorbable fixation device, the intermediate anchor 230 may be formed from a structure similar to that illustrated in Figure 20, which is molded into the pin or fit into a recess or against a transverse stop surface on the pin 205. Alternatively, the pin 205 may be formed from a tubular metal stock, and each of the axial strips 232 is formed by cutting a channel 244 such as a U shaped channel using conventional laser cutting or other techniques to isolate the anchor strip. The anchor strips may then be biased radially outwardly by prebending them slightly in excess of the elastic limit, to facilitate each strip 232 entering the corresponding aperture 242. Variations on the foregoing anchor structures may be readily envisioned by those of skill in the art in view of the disclosure herein.

25 The illustrated anchor assembly 230 (Fig. 20) includes a hub 235 carried by the pin, such that the distal end of each axially extending strip is attached to the hub. The hub may comprise an annular ring, which is rigidly affixed to or slidably carried by the pin 205. The axial strips may also be fixed directly to the pin 205, such as illustrated in Figure. 16A in which the strips are integrally formed with the pin 205. The shaft of pin 205 can be solid or cannulated to allow for insertion of guides such as k-wires.

30 The hub 235 or other structure which carries the anchor tines may be rotationally locked to the pin 205 and/or the actuator 210. Any of a variety of key or spline type relationships between the hub 235 and the pin 205 may be used. For example, an axially extending recess or groove in the pin 205 can receive a radially inwardly directed projection or extension of the hub 235. Alternatively, nonround complementary cross sectional configurations can be utilized for the pin 205 in the area of the hub 235. As a further alternative, the hub 235 or anchor tines can be insert molded within a bioresorbable or other polymeric pin 205. Similar antirotation locks can be utilized for the proximal anchor or collar, as discussed elsewhere herein. Antirotation structures may be desirable in certain

applications where rotation of the first and second bone fragments about the axis of the fixation pin may be clinically disadvantageous.

The actuator 210, as shown in Figure 22, comprises a tubular body 212 axially slidable on the pin. Figures 23-25 show additional views of the actuator. The distal end of the actuator may be provided with a tapered surface 246, such that proximal retraction of the pin with respect to the actuator causes the anchor to incline outwardly as it slides along the tapered surface. In one embodiment, the tapered surface 246 is provided on a metal leading ring 247, on an otherwise polymeric (e.g., absorbable) tubular body.

The actuator 210 can take any of a variety of forms, in addition to the tubular structure illustrated in Figures 22-25. For example, the actuator 210 may extend axially moveably within an internal lumen inside of the pin 205. Alternatively, the actuator 210 may comprise an axially extending pull wire or strip which extends along side of the pin 205. In an embodiment of the type illustrated in Figure 22, and dimensioned, for example, for use in a malleolar fracture, the tubular body 210 has an axial length of about 1.55 inches, and an outside diameter of about 0.172 inches. The inside diameter is approximately 0.138 inches, and the distal ramped surface 246 inclines at an angle of about 30° with respect to the longitudinal axis of the device. At least one axially extending stress release slot 242 extends through the retention structure 244, discussed below. The stress release slot has an axial length of about 0.200 inches, and a width of about 0.018 inches. The proximal collar 238, discussed below, has an outside diameter of about 0.275 inches.

The actuator 210 further comprises a collar 238. Collar 238 is axially movably disposed with respect to pin 205 by connection to actuator 210. The collar 238 seats against the proximal bone fragment to retain compression across the fracture. Collar 238 can be any of a variety of shapes or sizes, as has been discussed. The outer periphery of collar 238 can also have a radius in the axial direction or other adaptations to allow for countersinking or for cooperation with or to function as a fixation plate. The collar can act as a washer, with or without spikes for engaging tissue.

A retention structure 242 is preferably located on the actuator 210, permitting proximal movement of the pin with respect to the actuator, but resisting distal movement of the pin with respect to the actuator as has been discussed. The retention structure 242 may comprise a plurality of inwardly or outwardly extending annular rings or threads. The retention structure 242 on the actuator cooperates with the retention structure 240 on the pin to retain the device under compression. The retention structure may also include a rotational link or axially extending spline for cooperating with a complementary keyway or structure on the pin 205 to prevent rotation of the pin with respect to the actuator 210.

The actuator can be made from any of a variety of suitable materials or combination of materials. Preferably, the anchor is made from a metallic material, such as titanium or titanium alloy, although other materials including those disclosed elsewhere herein may be utilized for the present invention. The pin and actuator are preferably made of a bioabsorbable material, as previously discussed herein, such as Poly (L-lactide-co-D, L-lactide).

The proximal portion of the pin 205 can be sized to length or longer than required. The proximal portion of pin 205 which extends beyond the proximal end of actuator 210 after tensioning is preferably removed to minimize the projection of bone fixation device 200 from the surface of the bone. As previously discussed, at least a first break point may be provided on the pin 205 to facilitate breaking the proximal portion of the pin 205. A break point, which may be an annular recess, groove, or notch, provides a designed failure point if lateral force is applied to the proximal end 220 while the remainder of the fixation device 200 is securely fixed. At least a second break point may also be provided. Alternative methods of sizing to length may also be utilized, as known to those of skill in the art.

Although the present invention is disclosed as embodied in a bone fixation device 200 having a generally circular cross section, cross sections such as oval, rectangular, or square may be used. Independently, the pin 205 may be tapered along its length to cause radial along with axial bone compression. Furthermore, the device may be used in combination with support features, such as plates or intramedullary nails.

Figure 26 demonstrates the device 200 deployed for fracture fixation of the medial and lateral malleolar fractures. As the pin is proximally retracted with respect to the actuator, the anchor deploys radially outwardly from the pin in the proximal direction. The anchor 230 is typically embedded into the cancellous portion of the bone. The collar supports the proximal fragment of bone, provides compression as locking tension increases on the shaft, and initiates expansion of the umbrella.

Referring to Figures 27 through 30, there is disclosed another alternate embodiment of the fixation pin of the present invention. In many of the previous embodiments, the fixation pin was adapted for use in a through hole, which exited the backside of the bone. In some bones, and some types of fractures, however, the need for the pin to exit the rear surface of the bone may be disadvantageous. In these applications, the pin is preferably configured to anchor inside of the bone without the need to exist the rear surface. This is the case, for example, in certain anchor or attachment applications, as well as certain fixation application such as the Malleolar fixation illustrated in Figures 27 and 28, in which a bone fragment 407 is fixed to the bone 408.

The fixation device illustrated in Figures 29 and 30 comprises generally a fastener and pin assembly 380. The assembly 380 comprises a tubular sleeve 382 having a proximal end 384 and a distal end 386. Near the distal end 386 and preferably also at one or more additional positions along the tubular sleeve 382, the tubular sleeve 382 is provided with one or more anchors 388.

In the illustrated embodiment, the anchor 388 comprises a plurality of axially-extending strips 390 spaced apart circumferentially around the tubular sleeve 382. Each two adjacent axially-extending strips 390 is separated by a space 392. Space 392 may take the form of an axially and circumferentially-extending window, or an axially-extending slit as will be apparent to those of skill in the art.

The anchor 388 is designed such that as the axial length of the tubular sleeve 382 is shortened such as by axial compression, each axially-extending strip 390 is forced to fold radially outwardly as illustrated to provide an interference surface 394. Interference surface 394 is adapted to engage cancellous bone material to resist axial proximal withdrawal of the tubular sleeve 382 from the bone.

The anchor 388 may comprise two or more axially-extending strips 390, and, in one embodiment, comprises three axially-extending strips 390. Four or five or more axially-extending strips 390 may also be utilized for each anchor 388. Preferably, the axially-extending strips 390 are evenly circumferentially spaced around the tubular sleeve 382, to provide a radially symmetrical distribution of proximal force to the cancellous bone.

5           The total number of anchors 388, as well as the total surface area of the interference surfaces 394 can be varied to optimize the anchor retention force for each given application of the fastener and pin assembly 380.

The sleeve is preferably also provided with a proximal stop such as a proximal flange 396 which extends radially outwardly from the sleeve 382. Preferably, the flange 396 is slightly concave in the distal direction to provide a complimentary fit with the bone surface, and/or a spring effect with deformation.

10           Depending upon the construction of the tubular sleeve 382 and geometry of the strips 390, the point along strip 390 where bending occurs may vary. To facilitate reproducible bending of strip 390 and the creation of predictable interference surfaces 394, the strip 390 can be provided with one or more circumferentially extending grooves or other modifications which will preferentially bend under axial compression. For example, circumferential grooves can be located at the proximal end and distal end of each strip 390. An additional groove may also be desirable mid way between the  
15 proximal and distal ends.

The tubular sleeve 382 can be constructed in any of a variety of ways known in the art. For example, it can be injection molded in its final configuration. Alternatively, windows 392 can be cut into previously formed tube stock. Construction materials described elsewhere herein can be used for the present embodiment. The present embodiment can also be constructed generally in accordance with the dimensions discussed in connection with previous embodiments, or  
20 may be varied to suit the particular intended application. For applications such as that illustrated in Figures 27 and 28, for example, fastener and pin assembly 380 will generally be provided with an axial length on the order of from about 20 mm to about 70 mm.

The fastener and pin assembly 380 further comprises an axially-extending pin 398, which is axially movably disposed within the tubular sleeve 382. Pin 398 comprises a proximal end 400 and a distal end 402. The distal end 402 is  
25 axially interlocked with the distal end 386 of the tubular sleeve 382. In the illustrated embodiment, distal end 402 of pin 398 is provided with a stop 404 such as a radially outwardly-extending annular flange or cap having a diameter greater than the inside diameter of the tubular sleeve 382. In this manner, proximal displacement of the pin 398 within tubular sleeve 382 imparts an axially-compressive force on the tubular sleeve 382. Any of a variety of interference fit structures for providing a stop surface 404 can be utilized, as will be apparent to those of skill in the art in view of the disclosure  
30 herein.

The interior surface of the tubular sleeve 382 and outer surface of the pin 398 are provided with complimentary retention structures 406, such as any of those described previously herein, for permitting the pin 398 to be withdrawn proximally with respect to the proximal end of tubular sleeve 382, but to resist distal motion of the pin 398 with respect to tubular sleeve 382.

As will be apparent in view of Figures 27 and 28 and the discussion above, proximal withdrawal of the proximal pin end 400 with respect to the proximal flange 396 will cause the anchor 388 to collapse thereby forcing interference surfaces 394 to incline radially outwardly from the tubular sleeve 382 to engage cancellous bone while the bone fragment 407 is held against the bone 408. Following withdrawal of proximal pin end 400 to the desired tension, the proximal pin end 400 projecting beyond flange 396 may be severed as has been previously discussed.

In accordance with a feature which can be included in any of the embodiments disclosed herein, at least a portion of the pin 398 is provided with an outside diameter which tapers from a relatively larger diameter near the distal end 402 towards a relatively smaller diameter at the proximal end 400. The tubular sleeve 382 may be provided with a corresponding taper of its inside diameter from a relative large inside diameter at the distal end 86 to a relatively smaller inside diameter at the proximal end 384. The outside diameter of the tubular sleeve 382 may taper, or may remain substantially constant throughout. In this embodiment, proximal withdrawal of the pin 398 will cause a radial expansion of the tubular sleeve 382 to assist in retention of the tubular sleeve 382 within a bore in the bone.

Preferably, the corresponding tapered surfaces on the pin 398 and sleeve 382 are relatively dimensioned such that (disregarding the retention structures 406 for present purposes) the proximal end 400 of pin 398 can be inserted into the distal end 386 of sleeve 382 and the pin 398 can be freely advanced proximally into the sleeve 382 for an axial distance before the corresponding tapered surfaces engage. The corresponding tapered surfaces engage at a point where the axial compression on the tubular sleeve has already caused one or more anchor(s) 388 to deform. Further proximal axial motion of pin 398 within sleeve 382 will radially expand the portion of sleeve 382 which extends through cancellous bone while the radial expansion of anchor(s) may simultaneously continue.

In accordance with another aspect of the invention, the anchors can be preferentially sequentially deployed. This may be accomplished by providing the anchors with dissimilar wall thicknesses, or different depth grooves to facilitate bending, as will be apparent from the disclosure herein. In one embodiment of this feature, the distal anchors are deployed first upon proximal retraction of the pin. The middle anchor in a three-anchor system is deployed second, and the proximal anchor is deployed last. Further retraction of the pin causes a radial expansion of the tubular body, to provide a firm grip on the cancellous bone.

In use, the bone fragment 407 is held in position against bone 408 and a hole is drilled using conventional bone drilling techniques. The fastener and pin assembly 380 is then advanced into the hole, preferably over a guiding wire until proximal flange 396 is seated against the bone fragment 407. Proximal withdrawal of pin 398 with respect to flange 396 first causes axial compression and resulting radial expansion of one or more anchors 388. Further proximal withdrawal of pin 398 thereafter causes radial expansion of at least a portion of tubular sleeve 382. The appropriate pulling tension on pin 398 may then be applied to set retention structures 407 as desired.

The pin 398 is optionally provided with an axially-extending central lumen (not illustrated) for axially-slidably receiving an alignment pin therethrough. This allows the use of a self-tapping and drilling alignment pin (not illustrated), which can be drilled into the appropriate bone site as is known in the art. The fastener and pin assembly 380 may

thereafter be advanced over the proximal end of the pin and advanced distally along the pin until it is seated appropriately within the bone.

In one embodiment of the invention the overall length of the pin was about 70mm and the overall length of the sleeve was about 55mm in the uncompressed configuration. When compressed, the sleeve had a length of about 48mm.  
5 The outside diameter of the sleeve was about 6.5mm. The thickness of the proximal flange was about 1.3mm, and the diameter of the proximal flange was about 15mm. The diameter through the radially expanded anchors was about 11.0mm.

The specific dimensions of any of the bone fixation devices of the present invention can be readily varied depending upon the intended application, as will be apparent to those of skill in the art in view of the disclosure herein. In addition, although the several embodiments of the present invention were disclosed in the context of a cortical to cortical  
10 compression fixation which uses a through hole, and the most recent principle embodiment of the invention was disclosed in terms of a non-through hole application, either device may be readily dimensioned to suit the other application. Features from either device may also be incorporated into the other. For example, the embodiments of Figures 27 through 30 can readily be utilized in a through hole fixation of the type illustrated in Figure 1, with the distal most anchor 388 engaging the  
15 rear cortical surface and the proximal flange 396 engaging the proximal cortical surface. Intermediate anchors 388 such as are illustrated in Figures 27 through 30 may or may not be included in a through hole embodiment of the invention.

Referring to Figures 31-34, there is illustrated another version of the fixation device in accordance with the present invention. In this version, the fastener and pin assembly 380 includes a pin 398 having a proximal end 400 and a distal end 402. A stop 404 on the distal end 402 is provided with a proximally facing ramp 405. In one  
20 embodiment, the cross section of the stop 404 at the distal end of the ramp 405 is greater than the inside diameter at the distal end 386 of the tubular sleeve 382 and, preferably, is approximately equal to the outside diameter of tubular sleeve 382 at the distal end 386. In this manner, as is illustrated in Figure 34, proximal retraction of the proximal end 400 of pin 398 through the proximal flange 396 both compresses the anchors 388 and also draws the stop 404 inside the distal end 386 of tubular sleeve 382 to provide additional anchoring. Following deployment, the proximal  
25 extension of proximal end 400 beyond the proximal flange 396 may be severed, to produce a low profile surface as seen in Figure 34. As with previous embodiments, the pin 398 is preferably tapered from a relatively smaller diameter

---

Referring to Figure 36, the anchors 388 may be caused to preferentially bend in a predetermined fashion by providing a groove 391 or other engineered defect. The groove 391 may be formed during the initial molding or machining operations, or introduced in a post-molding step, such as by cutting, grinding or compression, or in accordance with other techniques which will be familiar to those of skill in the art. Thus, as an alternate to the illustrated groove 391, the wall thickness at the groove 391 may be reduced from the adjacent wall thickness.

Referring to Figure 37, there is illustrated an alternate embodiment of the fixation device in accordance with the present invention. In this embodiment, the distal anchors are adapted for positioning within the cancellus bone in a blind hole application. See, for example, Figures 27, 28, and 39. In the embodiment of Figures 37-39, the distal anchors are in the form of a plurality of biased ramps or barbs such as barbs 334 discussed previously. Due to the relative softness of cancellous bone, preferably two or three or four or more anchors are provided. Each anchor comprises one or more barbs 334. In the embodiment illustrated in Figure 38, each anchor comprises four barbs 334 residing in a common transverse plane.

The specific dimensions of any of the bone fixation devices of the present invention can be readily varied depending upon the intended application, as will be apparent to those of skill in the art in view of the disclosure herein.

Features from the various embodiments described above may also be incorporated into the other.

Although the present invention has been described in terms of certain preferred embodiments, other embodiments of the invention including variations in dimensions, configuration and materials will be apparent to those of skill in the art in view of the disclosure herein. In addition, all features discussed in connection with any one embodiment herein can be readily adapted for use in other embodiments herein. The use of different terms or reference numerals for similar features in different embodiments does not imply differences other than those which may be expressly set forth. Accordingly, the present invention is intended to be described solely by reference to the appended claims, and not limited to the preferred embodiments disclosed herein.

WHAT IS CLAIMED IS:

1. A bone fixation device, comprising:
  - an elongate support;
  - at least one axially compressible anchor on the support; and
  - 5 an elongate tapered pin, axially moveable with respect to the anchor;
  - wherein axial proximal withdrawal of the pin with respect to the support both radially enlarges at least a portion of the support and axially compresses the anchor thereby causing at least a portion of the anchor to incline radially outwardly from the support.
2. A bone fixation device as in Claim 1, wherein the support comprises a tubular body axially slidably  
10 carried on the pin.
3. A bone fixation device as in Claim 1, wherein the fixation device comprises a bioabsorbable material.
4. A bone fixation device as in Claim 1, further comprising a lock for permitting proximal withdrawal of the pin with respect to the support, but resisting distal advancement of the pin with respect to the support.
5. A bone anchor deployment system, comprising:  
15 a bone anchor deployment device, having a frame, an anchor connector for connection to the proximal end of a bone anchor and an anchor tensioning surface for resisting proximal movement of an anchor support; and
  - at least one bone anchor, having an elongate support, at least one radially expandable anchor on the support, and an elongate pin carried by the support;
  - 20 wherein the anchor connector and the pin have complimentary surface structures so that the anchor connector and pin are connectable to each other, and manipulation of the deployment device axially displaces the pin with respect to the support.
6. A bone anchor deployment system as in Claim 5, comprising at least two different sized bone anchors.
7. A bone anchor deployment system as in Claim 6, wherein each anchor is separately packaged in a sterile  
25 package.
8. A bone anchor deployment system as in Claim 5, wherein the support comprises a tubular body axially slidably carried by the pin.
9. A bone anchor deployment system as in Claim 5, wherein the anchor connector comprises a snap fit lock for engaging a recess on the pin.
- 30 10. A bone anchor deployment system as in Claim 5, wherein the pin comprises a break point which release the proximal end of the pin upon application of a sufficient tension.
11. A fixation pin for fixing bone to bone or other tissue to bone, comprising:
  - A body, having a proximal end and a distal end; and
  - A distal anchor on the body;



Wherein the distal anchor comprises at least a first retention surface on a first axially extending lever arm and a second retention surface on a second axially extending lever arm.

12. A fixation pin as in Claim 11, wherein the first and second retention surfaces are laterally moveable between a first, implantation crossing profile and a second, larger deployed crossing profile.
- 5 13. A fixation pin as in Claim 12, wherein the first and second retention surfaces are biased in the direction of the second crossing profile.
14. A fixation pin as in Claim 11, comprising at least three retention surfaces and at least three lever arms.
15. A fixation pin as in Claim 14, wherein at least a portion of each of the retention surfaces faces in a proximal direction.
- 10 16. A fixation pin as in Claim 11, integrally formed from a single piece of metal.
17. A fixation pin as in Claim 16, wherein the metal comprises titanium.
18. A fixation pin as in Claim 11, further comprising a retention structure on the body, for retaining a proximal anchor.
19. A fixation pin as in Claim 18, wherein the retention structure comprises a deviation in the surface of the  
15 body.
20. A fixation pin as in Claim 19, wherein the retention structure comprises a helical thread.
21. A fixation pin as in Claim 20, further comprising a proximal anchor carried by the body.
22. A fixation pin as in Claim 18, further comprising a breakpoint on the body.
23. A fixation pin as in Claim 11, further comprising a rotational coupling on the body, for removably  
20 rotationally coupling the body to a tool.
24. A fixation pin as in Claim 12, wherein the body includes a bore that extends longitudinally through the body from the proximal end to the distal end, the bore having a first portion at the proximal end and a second portion located adjacent the first portion, the second portion having a smaller diameter than the first portion.
25. A fixation pin as in Claim 24, further including a guide wire that extends through the bore and includes a  
25 distal portion configured to fit within the first portion so as to keep said first and second retention surfaces from laterally moving from the second, larger deployed crossing profile.
26. A fixation pin for fixing bone to bone or other tissue to bone, comprising:
- A tubular body, having a proximal end and a distal end;
- At least two slots in the tubular body, extending proximally from the distal end to define at least a  
30 first and a second axially extending lever arms;
- A proximally facing retention surface carried by each lever arm; and
- A retention structure on the body, for removably carrying a proximal anchor;
- Wherein the first and second retention surfaces are laterally movable between an implantation crossing profile and a deployed crossing profile.

27. A fixation pin as in Claim 26, wherein the retention structure comprises a thread on the body, proximal to the lever arms.
28. A fixation pin as in Claim 27, further comprising a proximal anchor carried by the body.
29. A fixation pin as in Claim 28, wherein the proximal anchor comprises an aperture for receiving the tubular body and a collar for seating against a tissue surface.
- 5 30. A fixation pin as in Claim 29, wherein rotation of the proximal anchor with respect to the tubular body moves the proximal anchor axially along the tubular body.
31. A fixation pin as in Claim 26, wherein the tubular body includes a bore that extends longitudinally through the tubular body from the proximal end to the distal end, the bore having a first portion at the proximal end and a second portion located adjacent to the first portion, the second portion having a diameter that is smaller than the first portion.
- 10 32. A fixation pin as in Claim 31, further including a guide wire that extends through the bore and includes a distal portion configured to fit within the first portion so as to keep said first and second retention surfaces from laterally moving from the deployed crossing profile.
- 15 33. A fixation pin for fixing a first material to bone, comprising:  
An elongate tubular body, having a proximal end and a distal end;  
A plurality of deflectable barbs carried by the distal end;  
A thread on the tubular body, in between the proximal end and the distal end; and  
A break point on the tubular body, proximal to at least a portion of the thread.
- 20 34. A fixation pin as in Claim 33, further comprising a proximal anchor, removably retained on the tubular body by the thread.
35. A fixation pin as in Claim 33, further comprising a rotational coupling on the pin, for coupling to a tool.
36. A fixation pin as in Claim 33, wherein each of the barbs is attached to the tubular body by an axially extending lever arm.
- 25 37. A fixation pin as in Claim 33, wherein the body includes a bore that extends longitudinally through the body from the proximal end to the distal end, the bore having a first portion at the proximal end and a second portion located adjacent the first portion, the second portion having a diameter smaller than the first portion.
38. A fixation pin as in Claim 33, further including a guide wire that extends through the bore and includes a distal portion configured to fit within the first portion so as to keep said first and second retention surfaces from laterally moving from the second, larger deployed crossing profile.
- 30 39. A bone fixation device, for securing a first bone fragment to a second bone fragment, comprising:  
an elongate pin, having a proximal end and a distal end;  
at least one radially advanceable anchor carried by the pin;  
an actuator, axially moveable with respect to the pin; and

at least one retention structure in between the pin and the actuator, for permitting proximal movement of the pin with respect to the actuator but resisting distal movement of the pin with respect to the actuator;

5 wherein axial proximal movement of the pin with respect to the actuator causes at least a portion of the anchor to advance along a path which is inclined radially outwardly from the pin in the proximal direction.

40. A bone fixation device as in Claim 39, wherein the actuator comprises a tubular body axially slidably carried on the pin.

10 41. A bone fixation device as in Claim 40, wherein the anchor comprises at least one axially extending strip carried by the pin, the strip moveable from an axial orientation to an inclined orientation in response to axial proximal retraction of the pin.

42. A bone fixation device as in Claim 41, wherein the anchor comprises at least two axially extending strips.

43. A bone fixation device as in Claim 42, comprising four axially extending strips.

15 44. A bone fixation device as in Claim 40, wherein the strip has a proximal end and a distal end and the proximal end is free.

45. A bone fixation device as in Claim 44, further comprising a hub carried by the pin, and the distal end of the strip is connected to the hub.

20 46. A bone fixation device as in Claim 44, wherein the hub comprises an annular ring, axially movably carried by the pin.

47. A bone fixation device as in Claim 44, wherein the hub is fixed with respect to the pin.

48. A bone fixation device as in Claim 39, further comprising a first retention structure on the actuator for cooperating with a second retention structure on the pin to retain the device under compression.

25 49. A bone fixation device as in Claim 39, wherein at least one of the actuator and the pin comprise a bioabsorbable material.

50. A bone fixation device as in Claim 49, wherein the material is selected from the group consisting of poly (L,co-D,L-lactide).

30 51. A bone fixation device as in Claim 39, further comprising a tapered surface on the distal end of the actuator, so that proximal retraction of the pin with respect to the actuator causes the anchor to incline outwardly as it slides along the tapered surface.

52. A bone fixation device as in Claim 39, wherein the pin has a proximal end, a distal end, and an outside diameter, and the pin has a relatively larger diameter near the distal end and a relatively smaller diameter proximally of the distal end.

53. A bone fixation device as in Claim 49, wherein the anchor comprises a nonabsorbable material.

35 54. A bone fixation device for fixing two or more bone fragments, comprising:

an elongate tubular body, having a proximal end, a distal end and a longitudinal axis;

a distal anchor on the fixation device, moveable from an axial orientation for distal insertion through a bore in the bone to an inclined orientation to resist axial movement through the bore;

5 an elongate pin axially moveable within the tubular body and linked to the anchor such that proximal retraction of the pin with respect to the tubular body advances the distal anchor from the axial orientation to the inclined orientation.

55. A bone fixation device as in Claim 54, further comprising a retention structure for retaining the distal anchor in the inclined orientation.

56. A bone fixation device as in Claim 54, further comprising a proximal anchor.

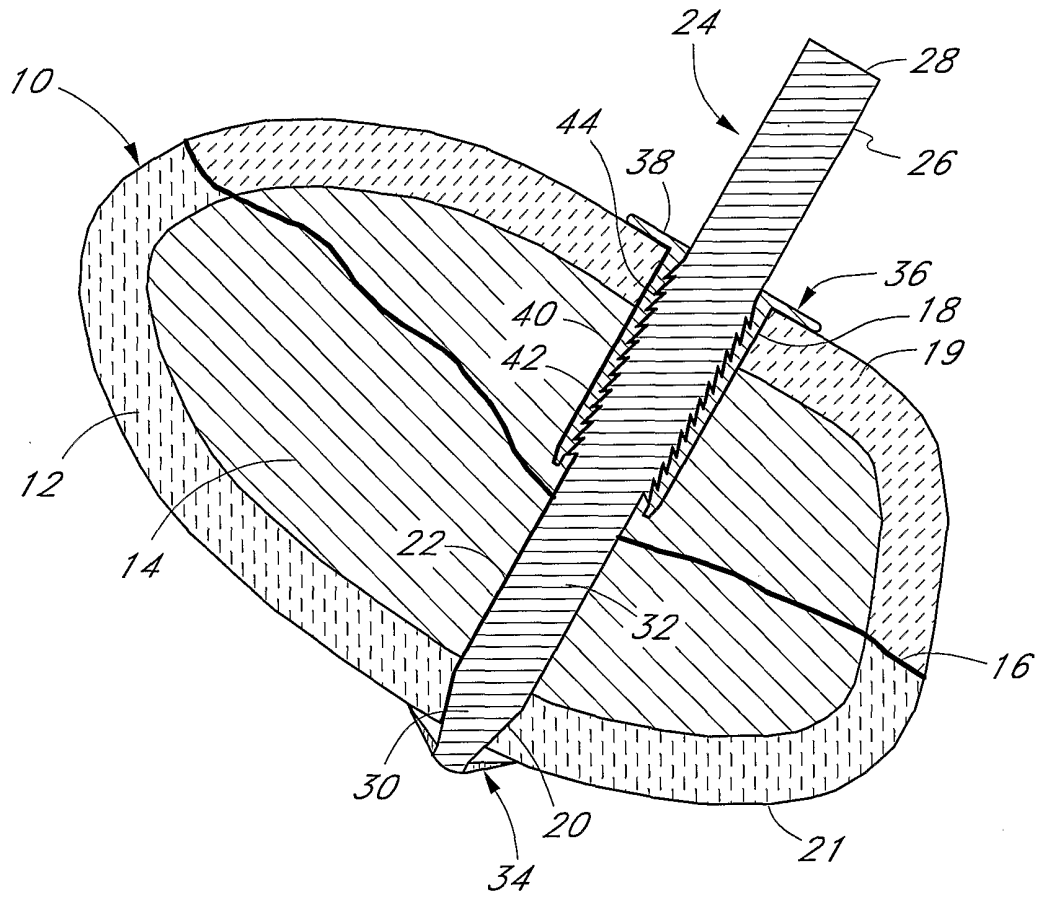
10 57. A bone fixation device as in Claim 54, wherein the distal anchor comprises at least two axially extending strips spaced circumferentially apart around the tubular body.

58. A bone fixation device as in Claim 55, wherein the retention structure comprises at least one ramped surface that inclines radially inwardly in the proximal direction.

15 59. A bone fixation device as in Claim 55, wherein the retention structure comprises at least one annular ridge.

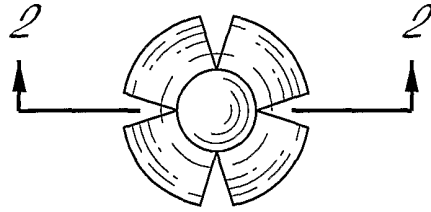
60. A bone fixation device as in Claim 54, further comprising a first retention structure on the tubular body, and a second, complimentary retention structure on the pin.

20 61. A bone fixation device as in Claim 54, wherein the tubular body comprises a first tapered surface and the pin comprises a second tapered surface such that proximal retraction of the pin with respect to the tubular body causes a radial enlargement of the tubular body.

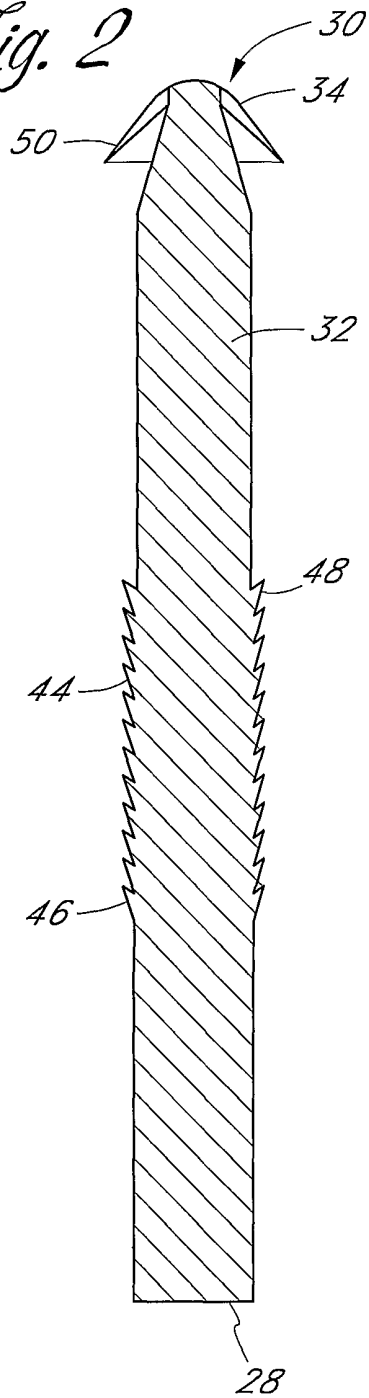


*Fig. 1*

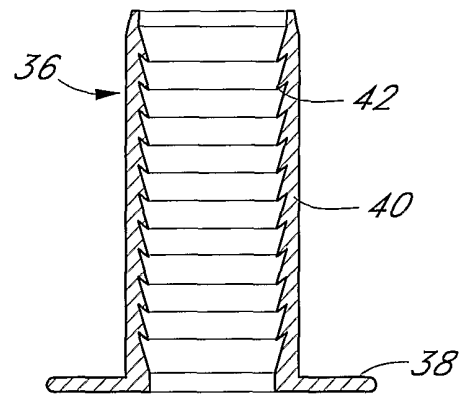
*Fig. 3*



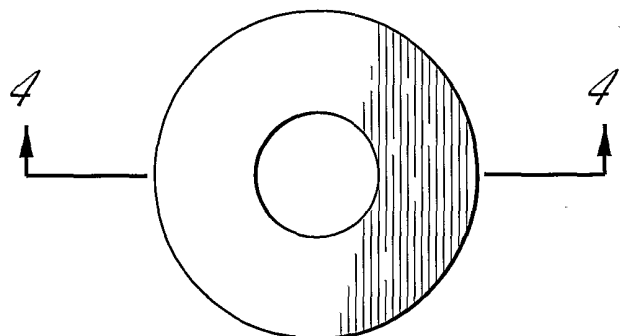
*Fig. 2*



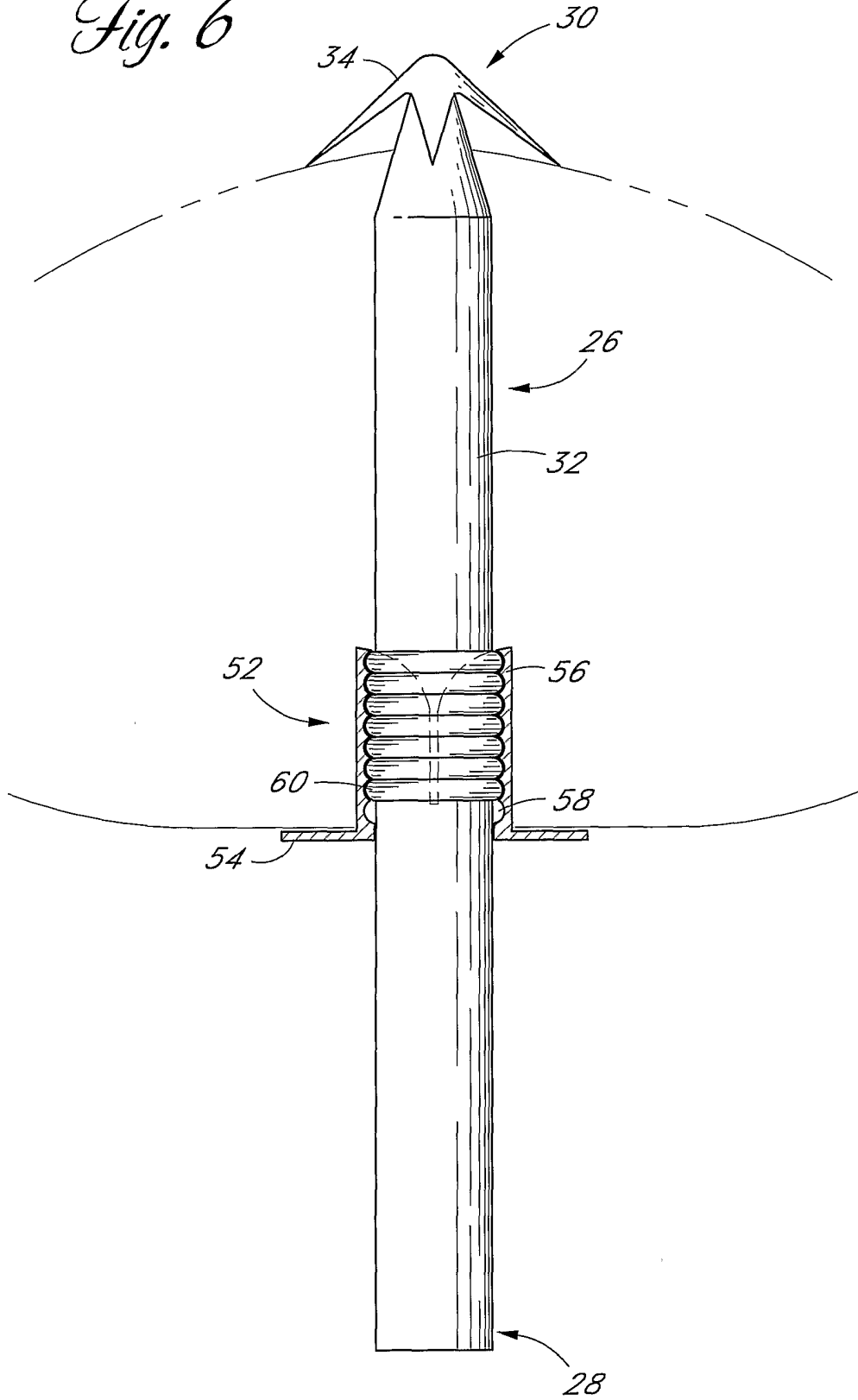
*Fig. 4*

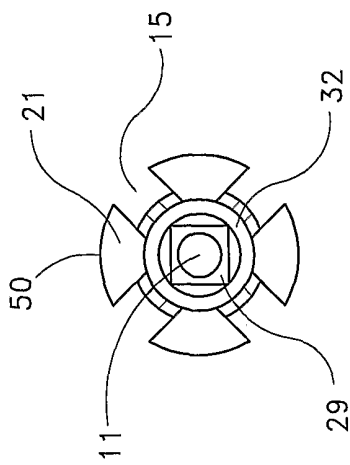


*Fig. 5*

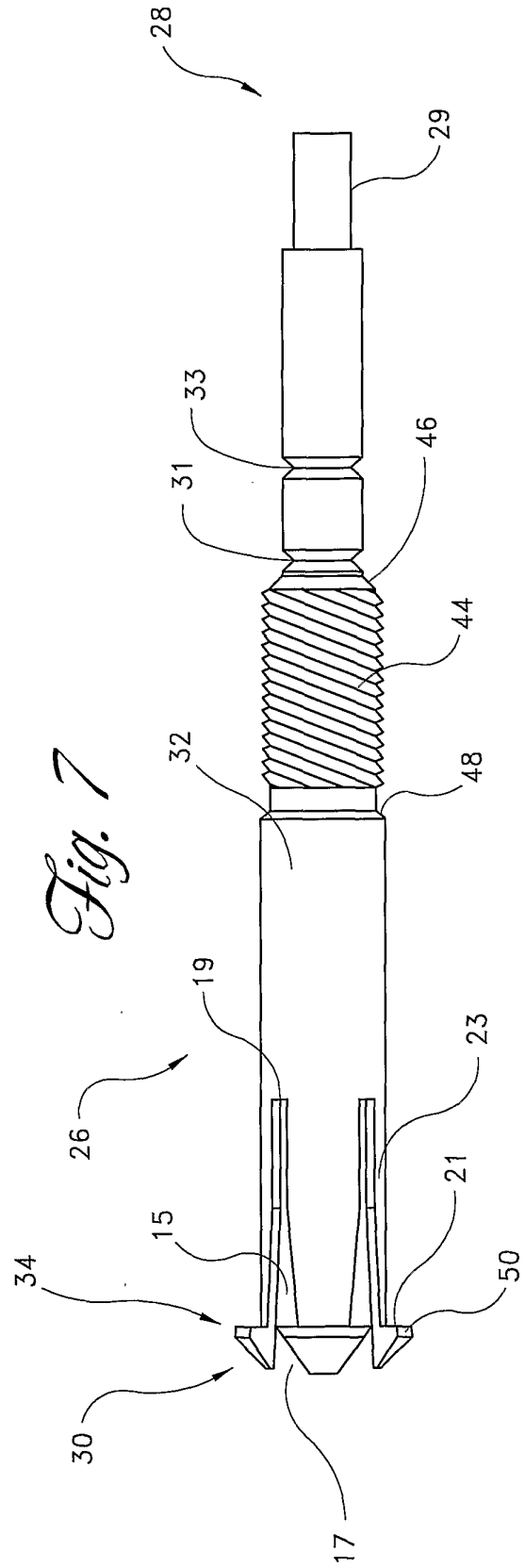


*Fig. 6*



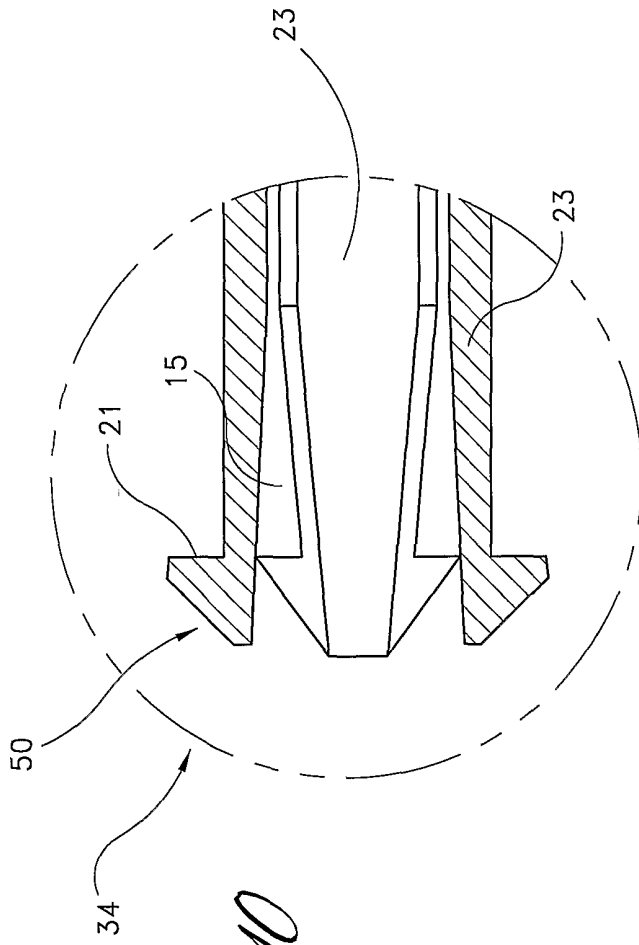


*Fig. 9*

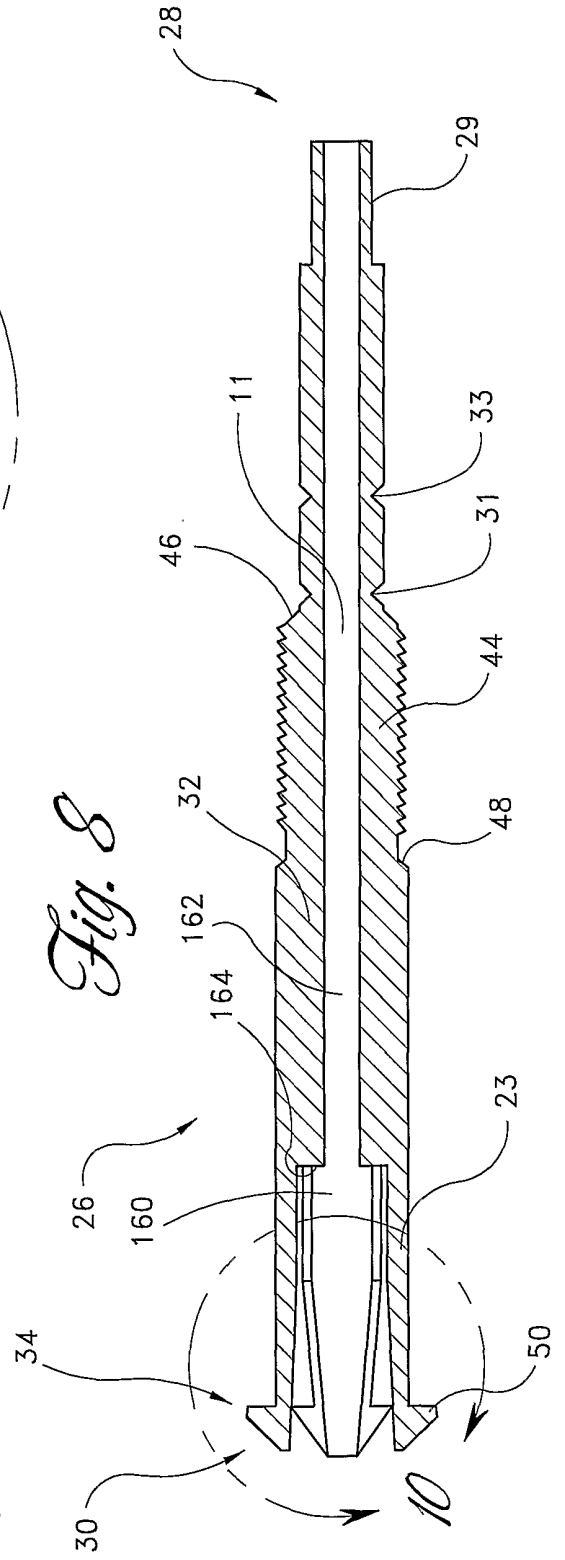


*Fig. 7*

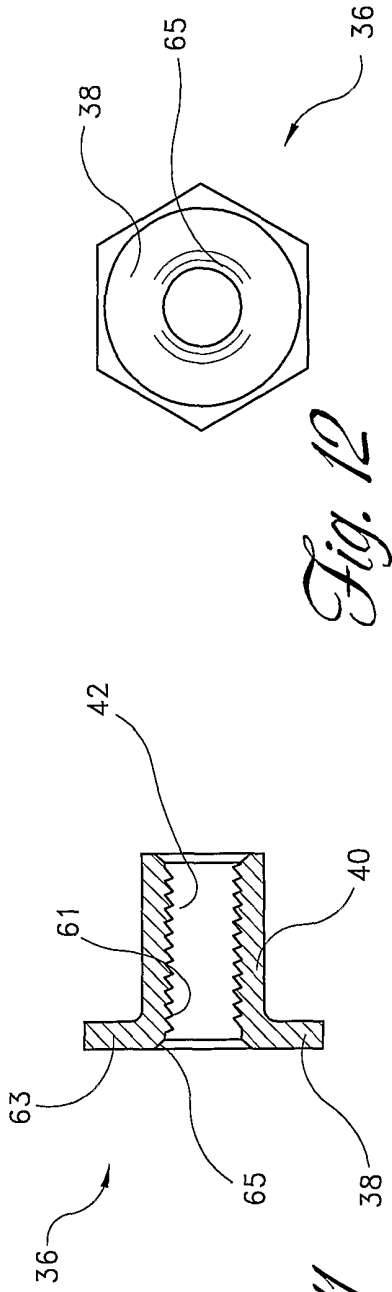




*Fig. 10*

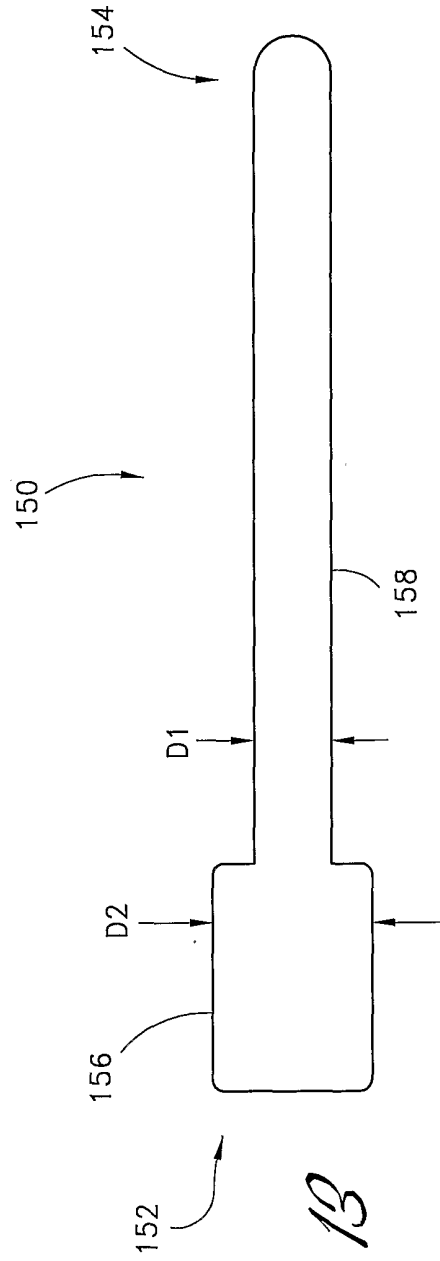


*Fig. 8*



*Fig. 12*

*Fig. 11*



*Fig. 13*

*Fig. 14*

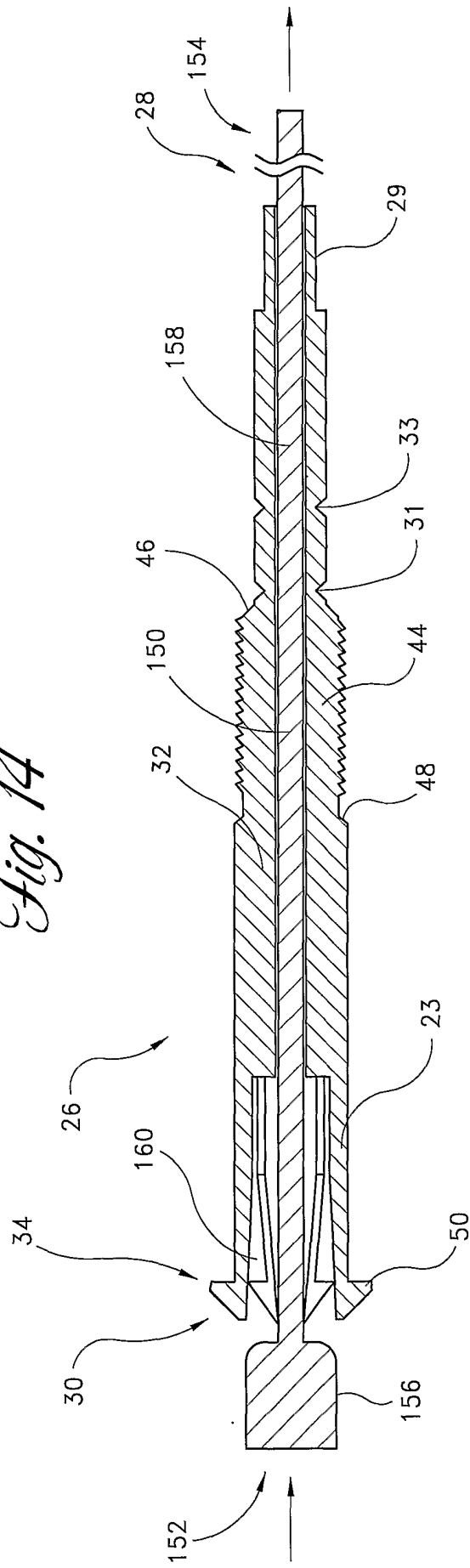


Fig. 15

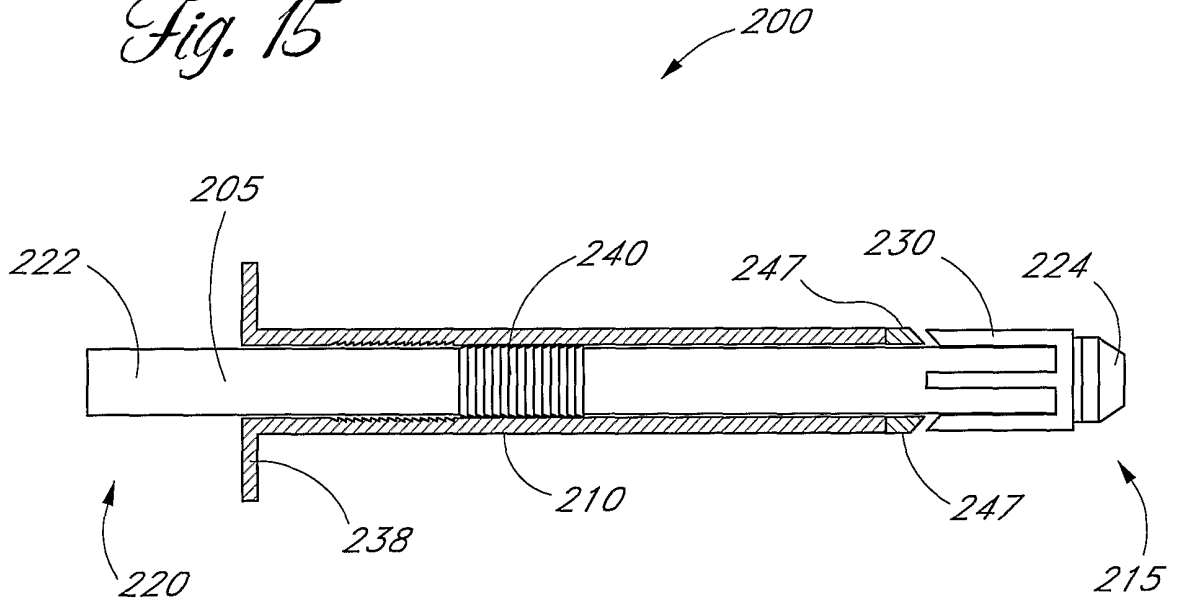
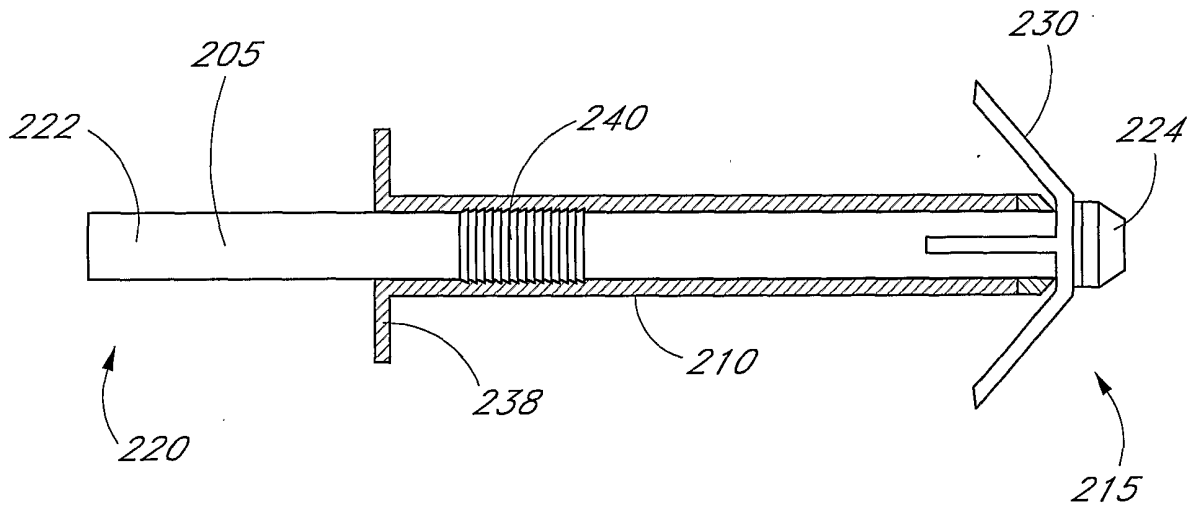
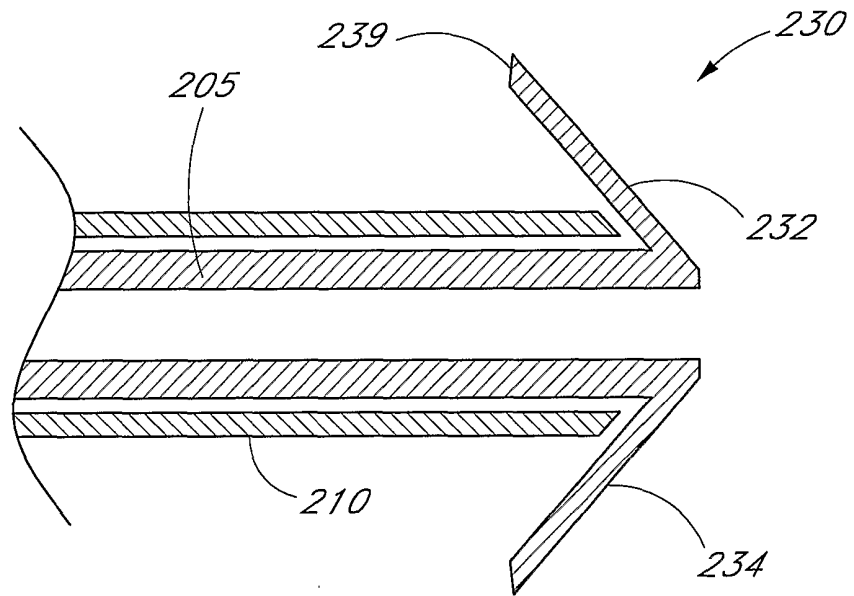


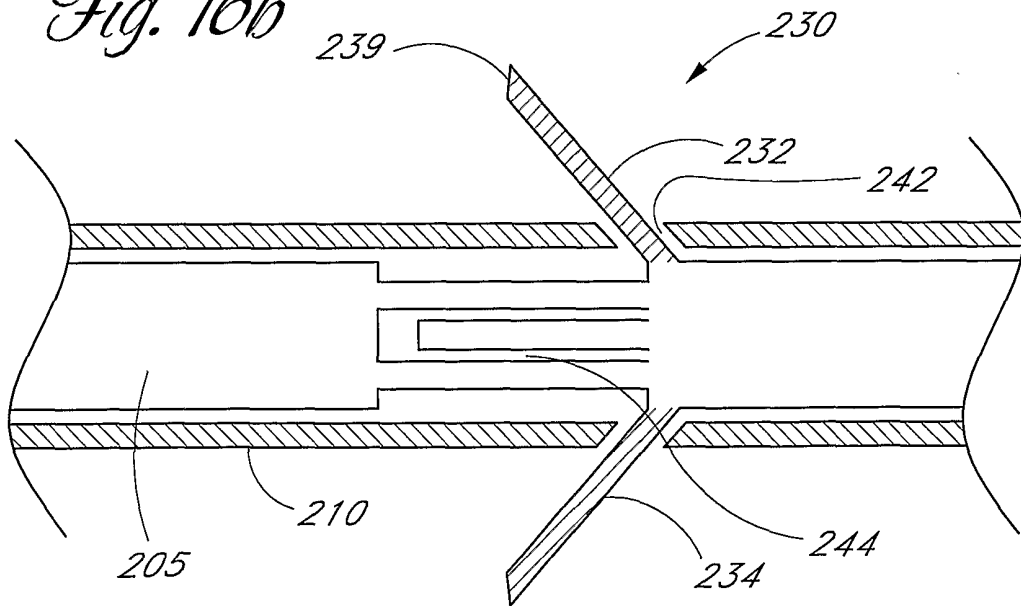
Fig. 16



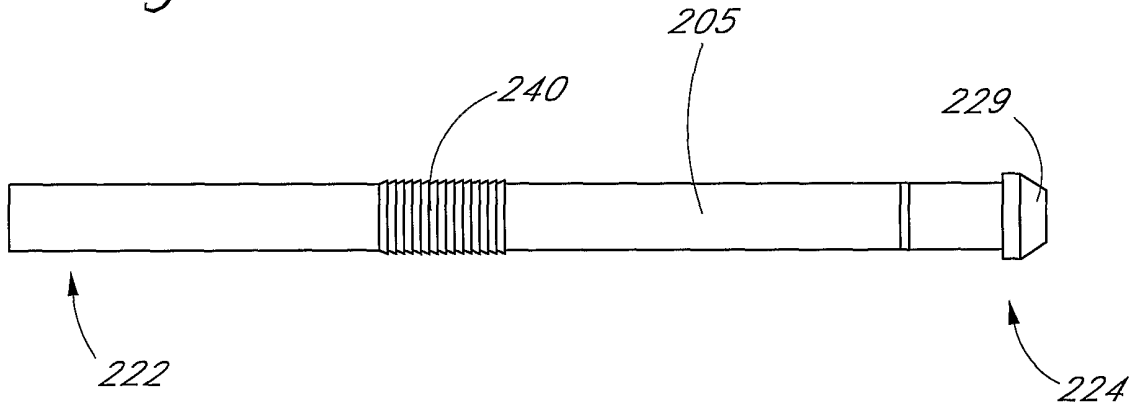
*Fig. 16a*



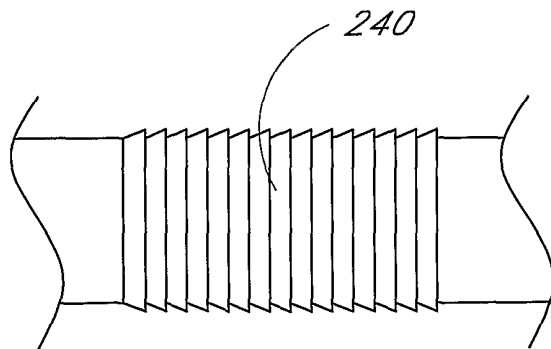
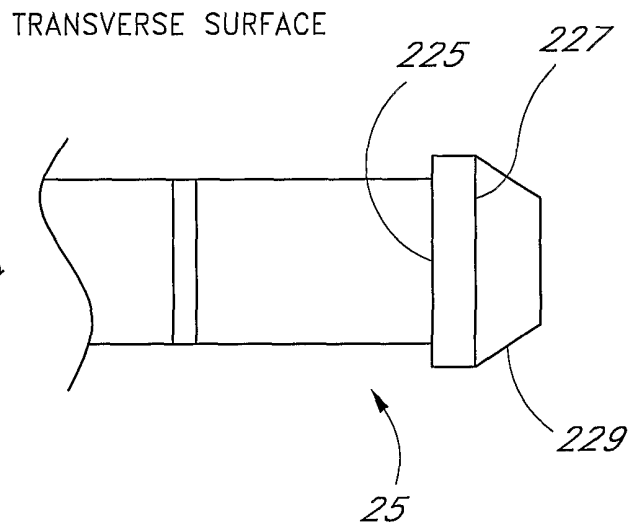
*Fig. 16b*



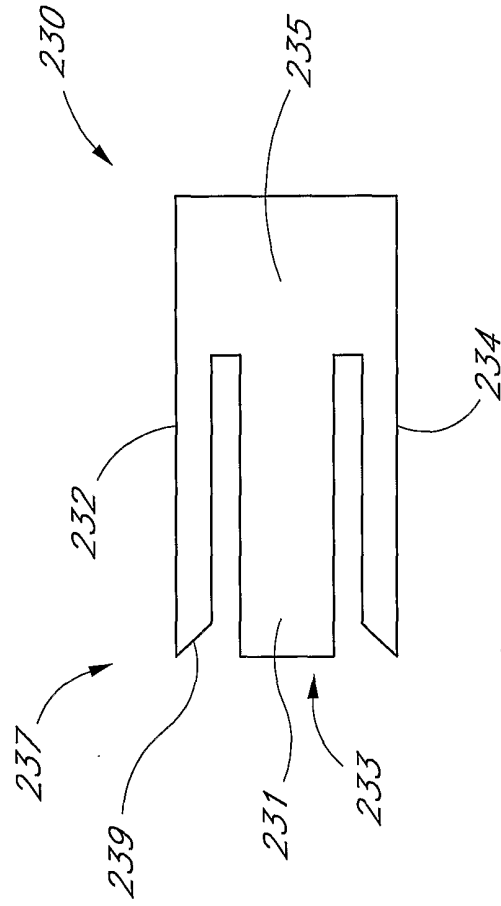
*Fig. 17*



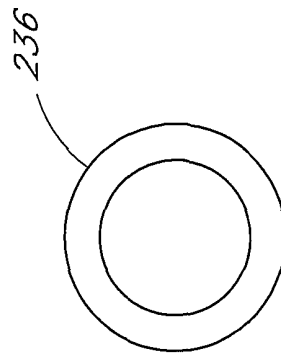
*Fig. 18*



*Fig. 19*

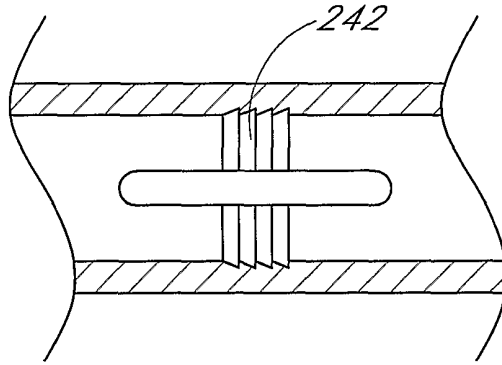


*Fig. 20*

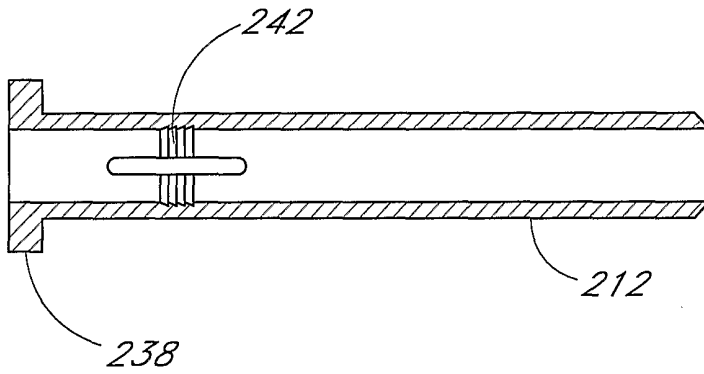


*Fig. 21*

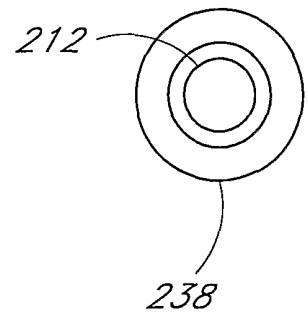
*Fig. 25*



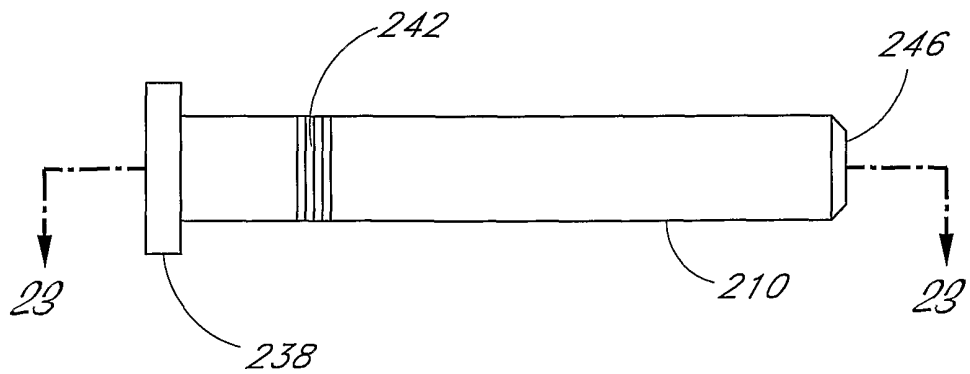
*Fig. 23*



*Fig. 24*



*Fig. 22*





*Fig. 26*

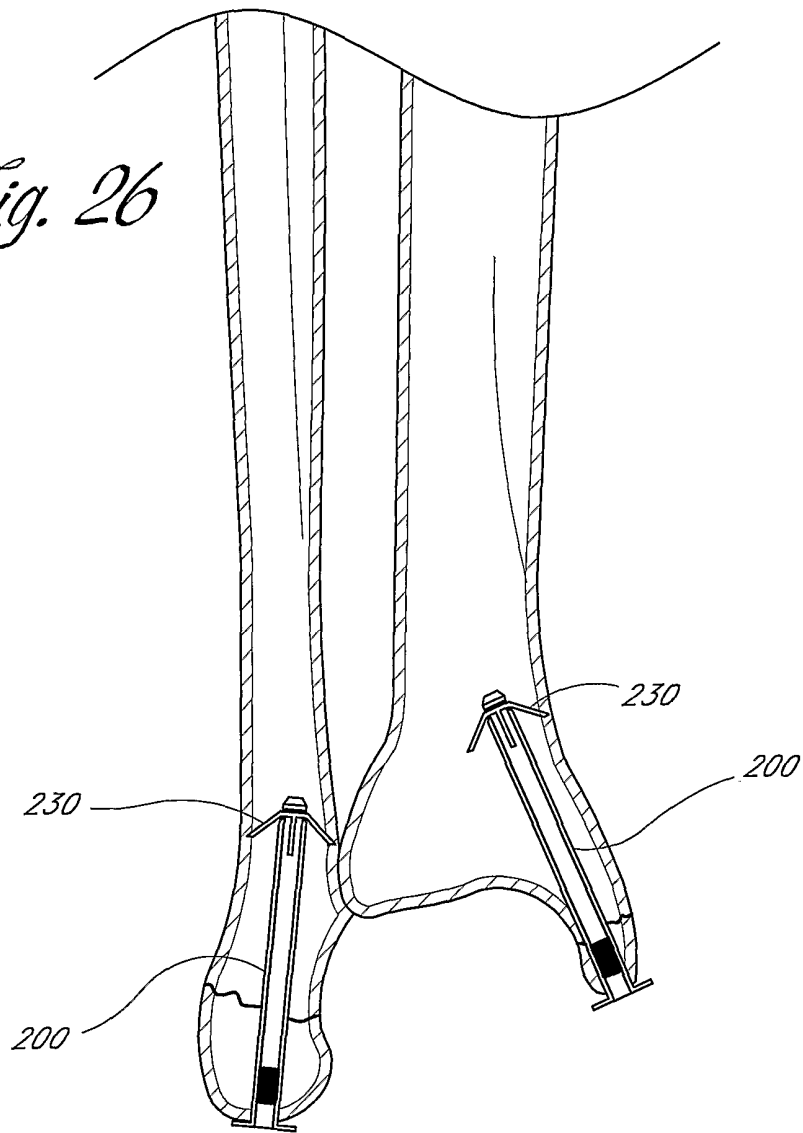


Fig. 28

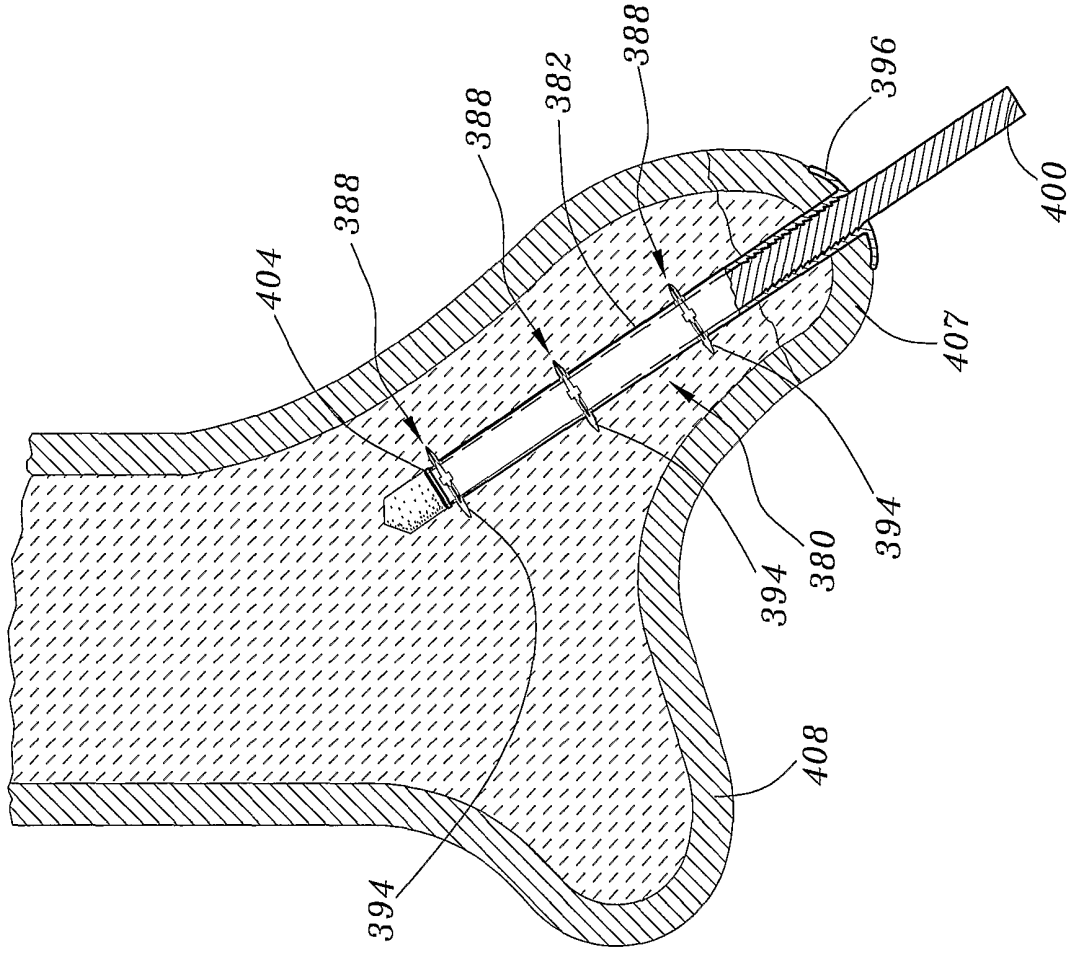


Fig. 27

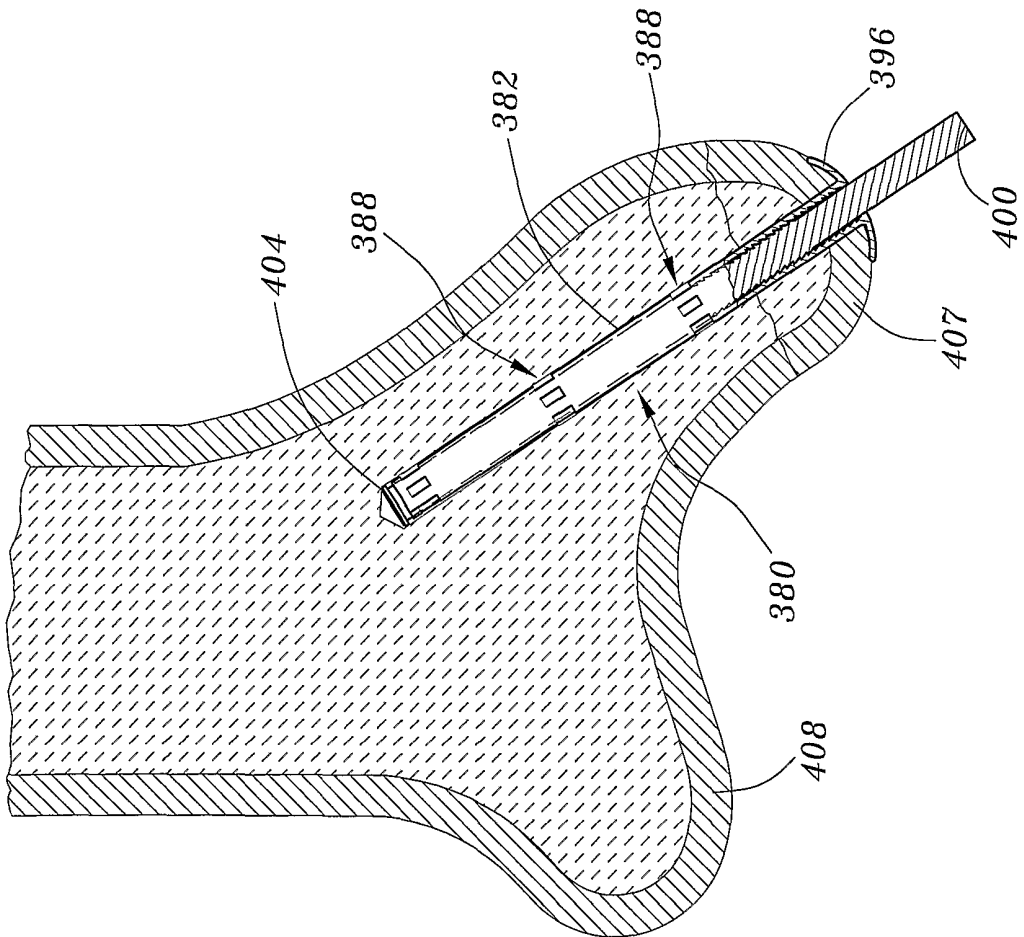


Fig. 29

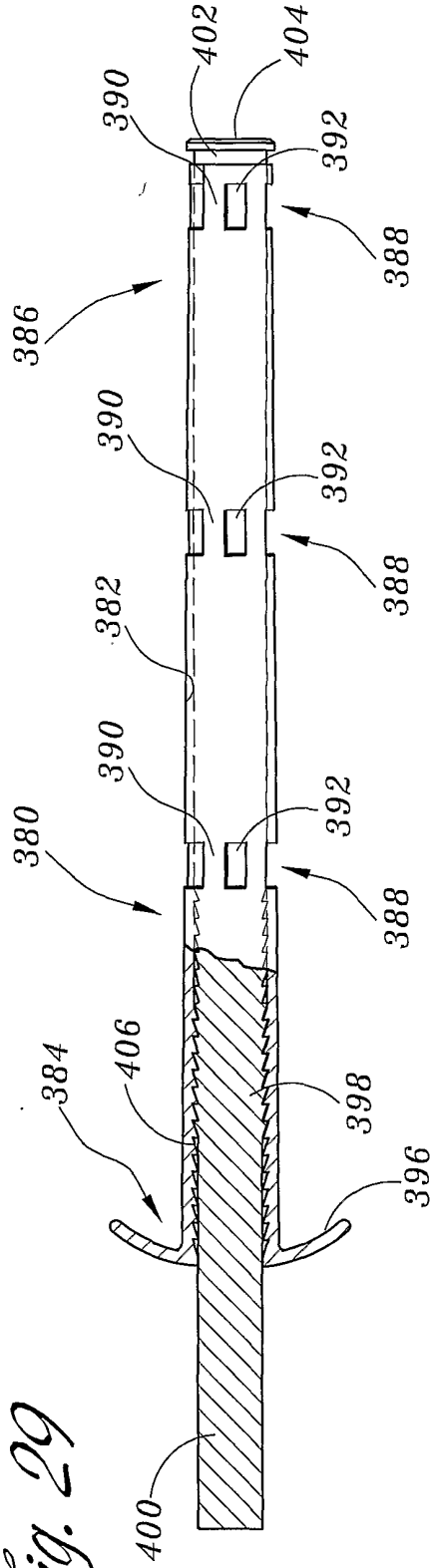
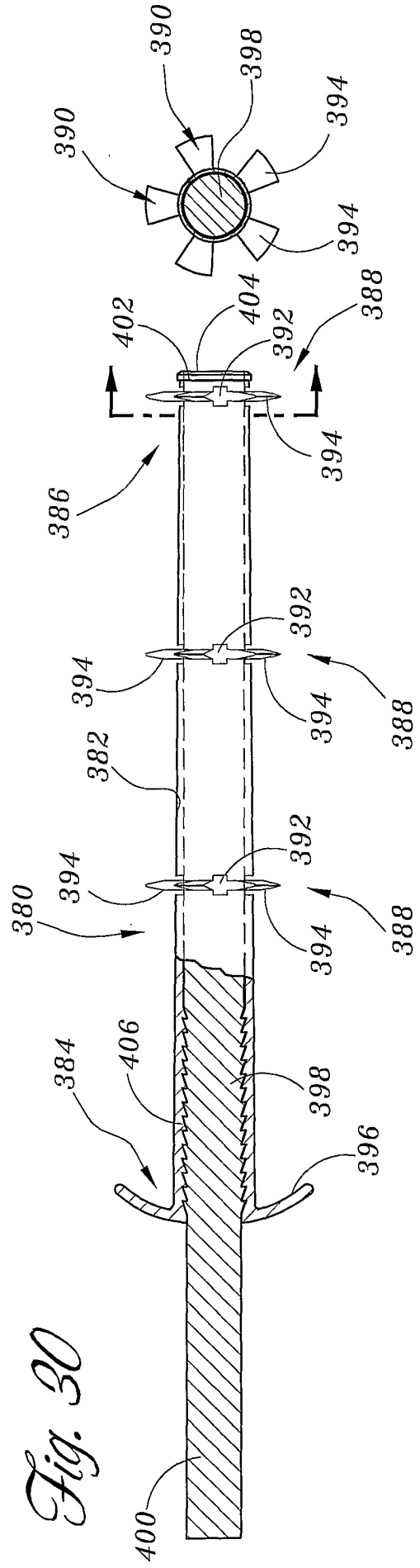
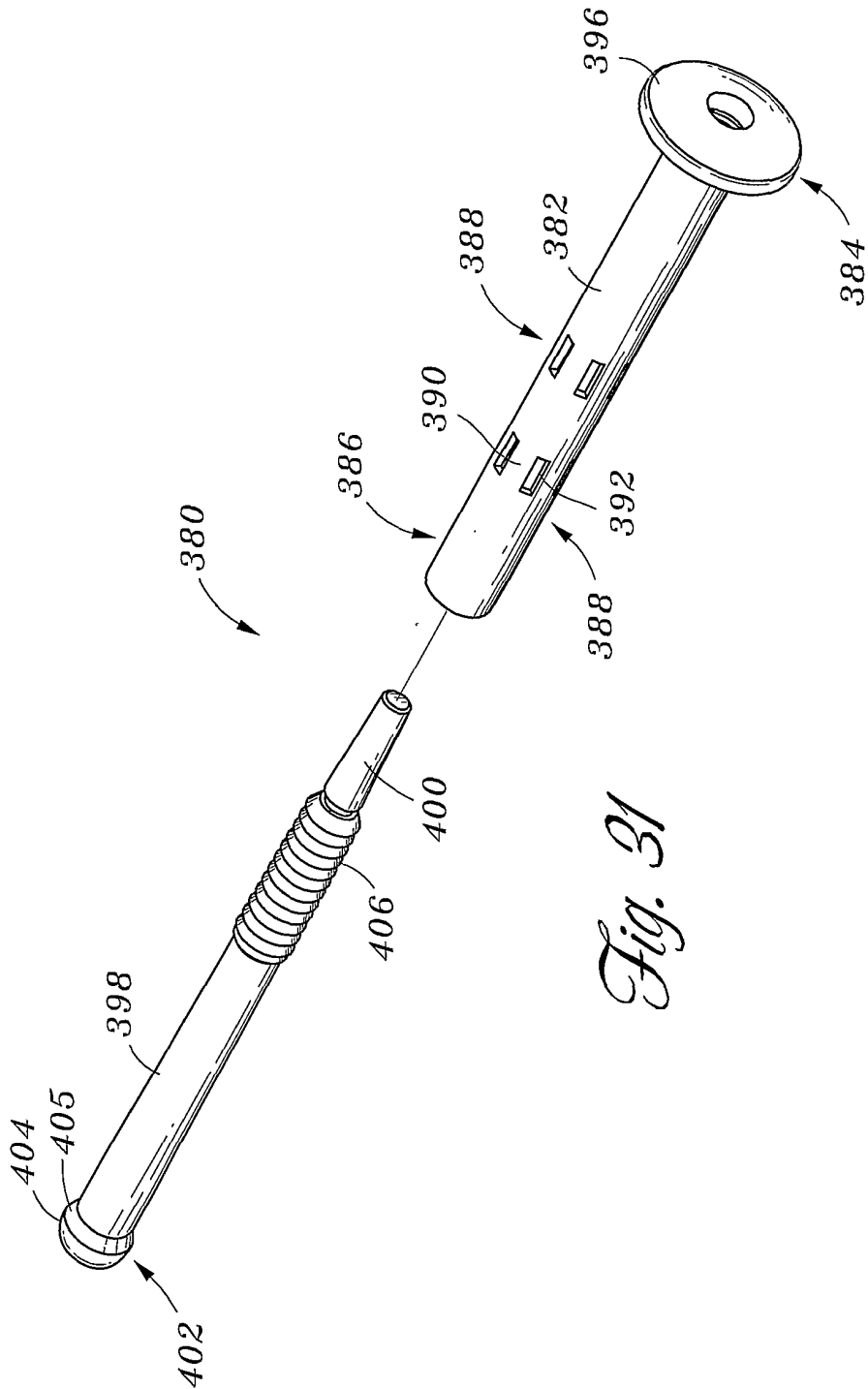
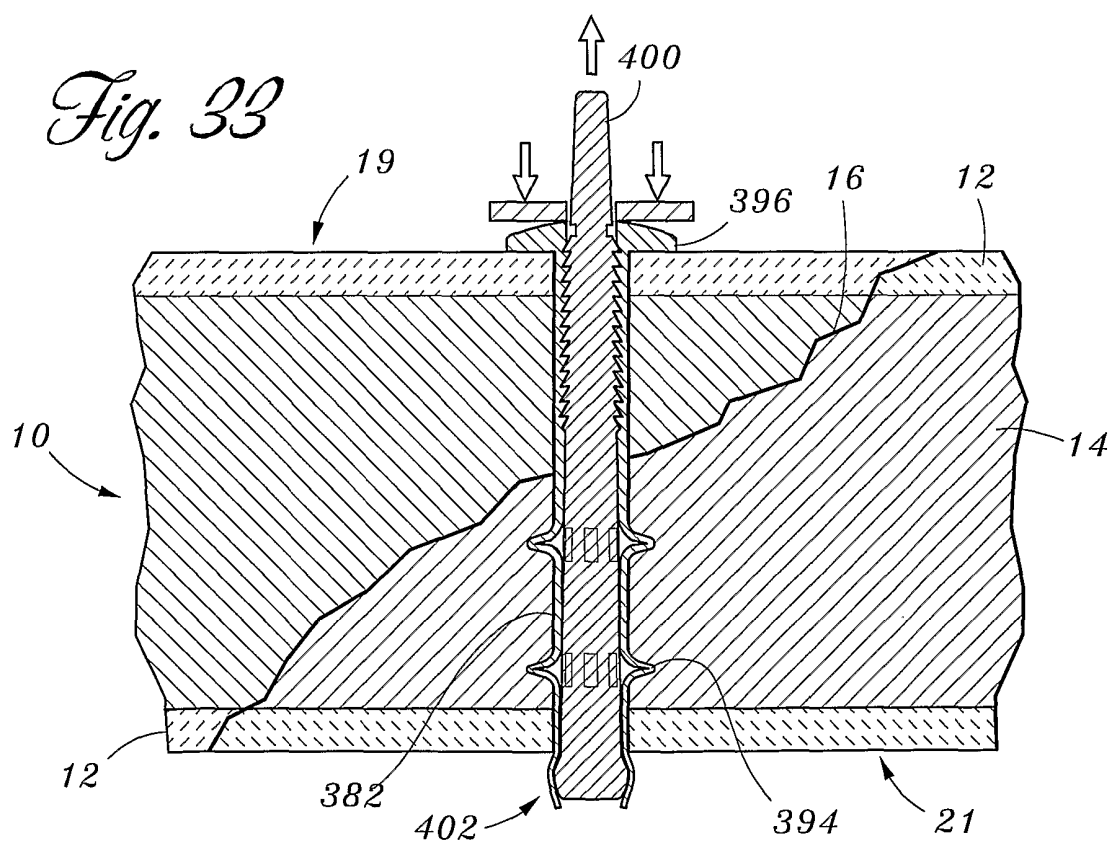
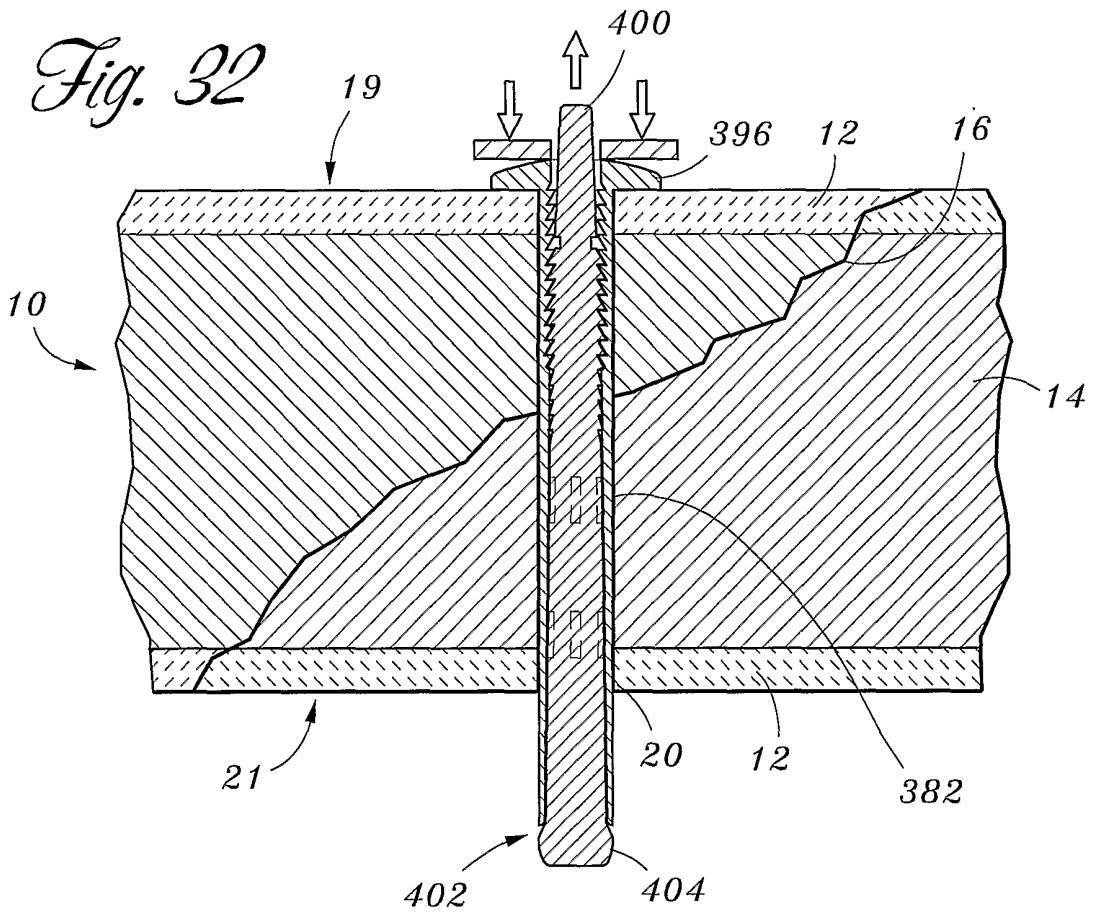


Fig. 30

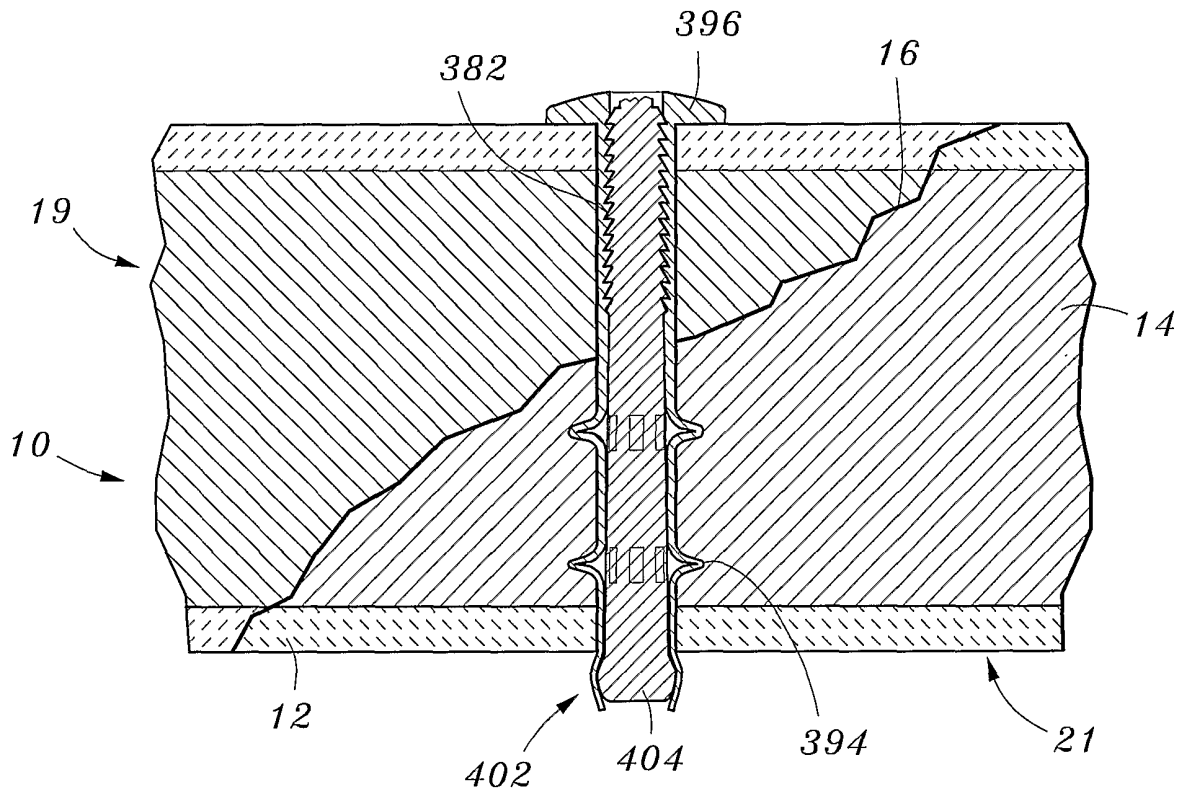


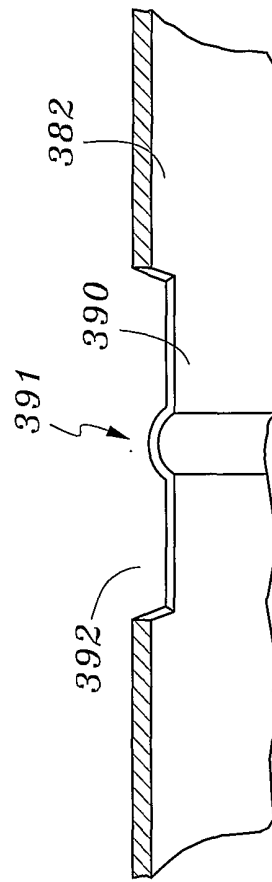
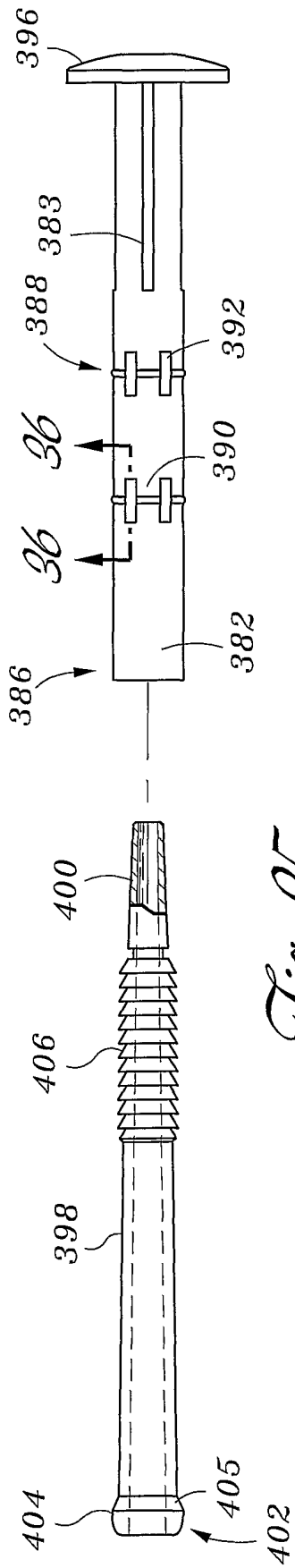


*Fig. 31*

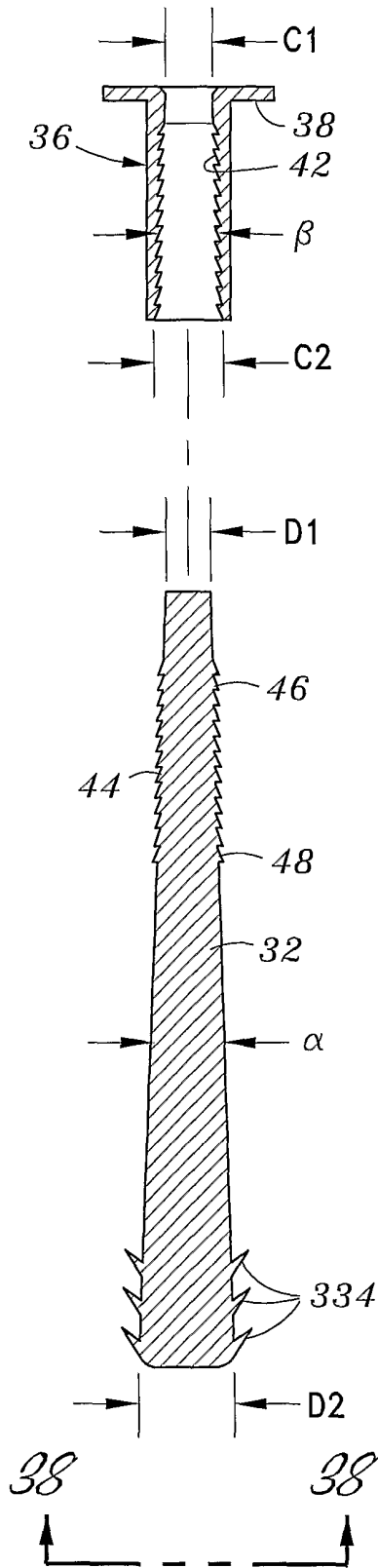


*Fig. 34*

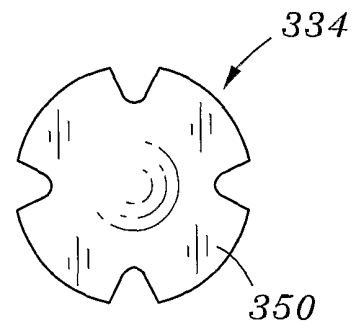




*Fig. 37*

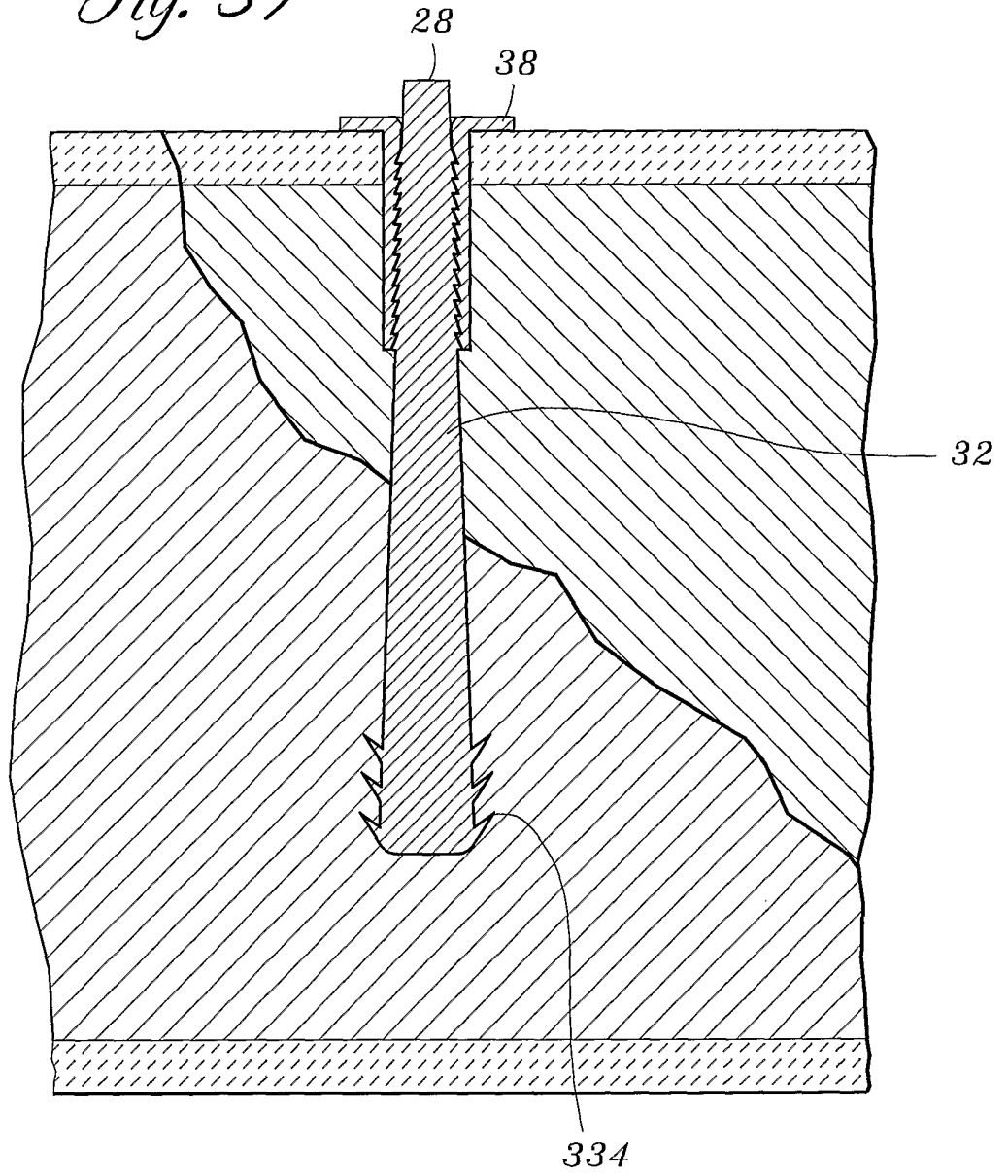


*Fig. 38*





*Fig. 39*



## INTERNATIONAL SEARCH REPORT

International application No.

PCT/US01/13366

<b>A. CLASSIFICATION OF SUBJECT MATTER</b>		
IPC(7) : A61B 17/58 US CL : 606/72		
According to International Patent Classification (IPC) or to both national classification and IPC		
<b>B. FIELDS SEARCHED</b>		
Minimum documentation searched (classification system followed by classification symbols)		
U.S. : 60653, 60, 62, 63, 68, 72, 73, 232		
Documentation searched other than minimum documentation to the extent that such documents are included in the fields searched		
Electronic data base consulted during the international search (name of data base and, where practicable, search terms used)		
<b>C. DOCUMENTS CONSIDERED TO BE RELEVANT</b>		
Category*	Citation of document, with indication, where appropriate, of the relevant passages	Relevant to claim No.
A	US 5,725,541 A (ANSPACH, III et al), 10 March 1998, all.	
A	US 5,501,695 A (ANSPACH, JR. et al) 26 March 1996, all.	
A	GB 2173565A (HIMOUD) 15 October 1986, all.	
<input type="checkbox"/> Further documents are listed in the continuation of Box C. <input type="checkbox"/> See patent family annex.		
* Special categories of cited documents:	"I" later document published after the international filing date or priority date and not in conflict with the application but cited to understand the principle or theory underlying the invention	
"A" document defining the general state of the art which is not considered to be of particular relevance	"X" document of particular relevance; the claimed invention cannot be considered novel or cannot be considered to involve an inventive step when the document is taken alone	
"E" earlier document published on or after the international filing date	"Y" document of particular relevance; the claimed invention cannot be considered to involve an inventive step when the document is combined with one or more other such documents, such combination being obvious to a person skilled in the art	
"L" document which may throw doubts on priority claim(s) or which is cited to establish the publication date of another citation or other special reason (as specified)	"G" document member of the same patent family	
"O" document referring to an oral disclosure, use, exhibition or other means		
"P" document published prior to the international filing date but later than the priority date claimed		
Date of the actual completion of the international search	Date of mailing of the international search report	
16 JULY 2001	05 SEP 2001	
Name and mailing address of the ISA/US Commissioner of Patents and Trademarks Box PCT Washington, D.C. 20231	Authorized officer DAVID O. REIP	
Facsimile No. (703) 305-3230	Telephone No. (703) 308-0858	