

(19) World Intellectual Property Organization
International Bureau



(43) International Publication Date
29 March 2007 (29.03.2007)

PCT

(10) International Publication Number
WO 2007/035700 A2

(51) International Patent Classification: **Not classified**

(21) International Application Number:
PCT/US2006/036418

(22) International Filing Date:
19 September 2006 (19.09.2006)

(25) Filing Language: English

(26) Publication Language: English

(30) Priority Data:
60/718,389 19 September 2005 (19.09.2005) US

(71) Applicant (for all designated States except US): **INGER-SOLL-RAND COMPANY** [US/US]; 155 Chestnut Ridge Road, Montvale, NJ 07645 (US).

(72) Inventors; and

(75) Inventors/Applicants (for US only): **MARIANI, Filippo** [IT/IT]; Via Bracciano, 42, I-20124 Milan (IT). **ROBB, Jay, L.** [US/US]; 419 Briarcliff, Rockwell, NC 28138 (US).

(74) Agents: **SMITH, David, B.** et al.; **MICHAELS BEST & FRIEDRICH LLP**, 100 East Wisconsin Avenue, Suite 3300, Milwaukee, WI 53202-4108 (US).

(81) Designated States (unless otherwise indicated, for every kind of national protection available): AE, AG, AL, AM, AT, AU, AZ, BA, BB, BG, BR, BW, BY, BZ, CA, CH, CN, CO, CR, CU, CZ, DE, DK, DM, DZ, EC, EE, EG, ES, FI, GB, GD, GE, GH, GM, HN, HR, HU, ID, IL, IN, IS, JP, KE, KG, KM, KN, KP, KR, KZ, LA, LC, LK, LR, LS, LT, LU, LV, LY, MA, MD, MG, MK, MN, MW, MX, MY, MZ, NA, NG, NI, NO, NZ, OM, PG, PH, PL, PT, RO, RS, RU, SC, SD, SE, SG, SK, SL, SM, SV, SY, TJ, TM, TN, TR, TT, TZ, UA, UG, US, UZ, VC, VN, ZA, ZM, ZW.

(84) Designated States (unless otherwise indicated, for every kind of regional protection available): ARIPO (BW, GH, GM, KE, LS, MW, MZ, NA, SD, SL, SZ, TZ, UG, ZM, ZW), Eurasian (AM, AZ, BY, KG, KZ, MD, RU, TJ, TM), European (AT, BE, BG, CH, CY, CZ, DE, DK, EE, ES, FI, FR, GB, GR, HU, IE, IS, IT, LT, LU, LV, MC, NL, PL, PT, RO, SE, SI, SK, TR), OAPI (BF, BJ, CF, CG, CI, CM, GA, GN, GQ, GW, ML, MR, NE, SN, TD, TG).

Published:
— without international search report and to be republished upon receipt of that report

For two-letter codes and other abbreviations, refer to the "Guidance Notes on Codes and Abbreviations" appearing at the beginning of each regular issue of the PCT Gazette.

(54) Title: MULTI-STAGE COMPRESSION SYSTEM INCLUDING VARIABLE SPEED MOTORS

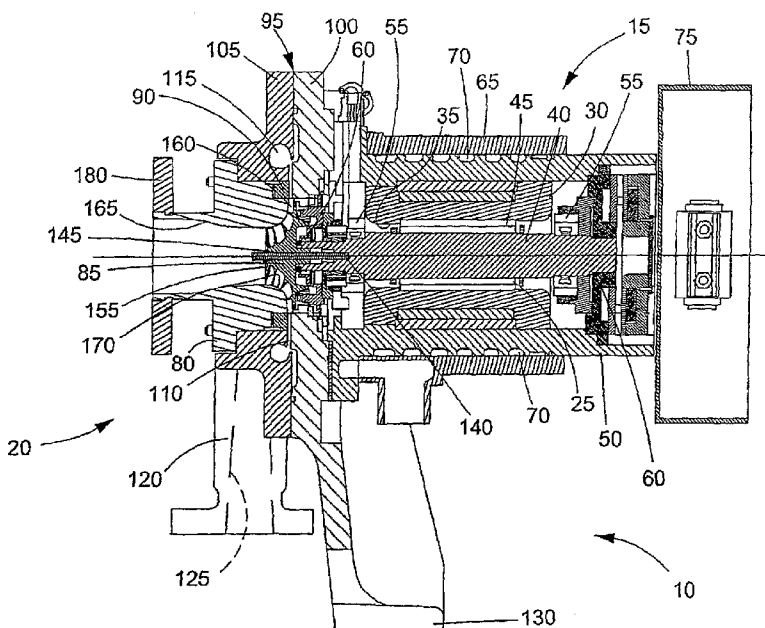

(57) Abstract: A multi-stage fluid compression system includes a first centrifugal compressor stage having a first inlet and a first outlet and a second centrifugal compressor stage having a second inlet and a second outlet. The second inlet receives a flow of compressed fluid from the first outlet. A first variable-speed motor is coupled to the first centrifugal compressor stage and is operable to drive the first centrifugal compressor stage at a first speed. A second variable speed motor is coupled to the second centrifugal compressor stage and is operable to drive the second centrifugal compressor stage at a second speed. The first speed and the second speed are each independently variable.

WO 2007/035700 A2

MULTI-STAGE COMPRESSION SYSTEM INCLUDING VARIABLE SPEED MOTORS

CROSS REFERENCE TO RELATED APPLICATIONS

[0001] This application claims priority under 35 U.S.C. sec. 119 to provisional patent application no. 60/718,389, filed on Sept. 19, 2005, which is hereby fully incorporated by reference.

BACKGROUND

[0002] The invention relates to a centrifugal compressor system including two or more compression stages. More particularly, the invention relates to a centrifugal compressor system that includes multiple compression stages independently driven by a directly connected high-speed, variable speed electric motor preferably equipped with active magnetic bearings.

[0003] Multiple stage compressor units have been used to provide a higher pressure than would be possible with a single compressor unit. These units are generally driven by a single drive so that all motors operate at a uniform speed or speed ratio.

[0004] The use of a single drive motor makes it difficult to vary the operation of one stage with respect to the other stages. For example, a first stage may be operated at an optimal speed under certain conditions. However, this speed may be less than optimal for the other stages. If the stages are driven by a common drive member, the speed of one cannot be varied without changing the speed of the other.

SUMMARY

[0005] In one embodiment, the invention provides a multi-stage fluid compression system that includes a first centrifugal compressor stage having a first inlet and a first outlet and a second centrifugal compressor stage having a second inlet and a second outlet. The second inlet receives a flow of compressed fluid from the first outlet. A first variable-speed motor is coupled to the first centrifugal compressor stage and is operable to drive the first centrifugal compressor stage at a

first speed. A second variable speed motor is coupled to the second centrifugal compressor stage and is operable to drive the second centrifugal compressor stage at a second speed. The first speed and the second speed are each independently variable.

[0006] In another embodiment, the invention provides a multi-stage compression system that includes a plurality of centrifugal compressor units. Each compressor unit has an inlet and an outlet. A first of the compressor units draws in a fluid at a first pressure, and a last of the compressor units discharges the fluid at a second pressure. The compression system also includes a plurality of variable-speed motors. Each motor directly drives one of the plurality of compressor units. Each motor is operable at a speed between a motor minimum and a motor maximum independent of the other motors. A control system is operable to vary the speed of each motor independently at least partially in response to the second pressure.

[0007] Other aspects of the invention will become apparent by consideration of the detailed description and accompanying drawings.

BRIEF DESCRIPTION OF THE DRAWINGS

[0008] Figure 1 shows the cross-section of a compression module.

[0009] Figure 2 is a cross-sectional view of a compressor inlet of the compression module of Figure 1.

[0010] Figure 3 shows a perspective view of the compression module in a horizontal configuration.

[0011] Figure 4 is a perspective view of the compression module in a vertical configuration.

[0012] Figure 5 is an illustration of the connections and flow from one stage of compressor and heat exchanger to another.

[0013] Figure 6 is a schematic of an embodiment of the compression system.

[0014] Figure 7 is a schematic of two motors, one motor driving one compressor and the other motor driving two compressors.

DETAILED DESCRIPTION

[0015] Before any embodiments of the invention are explained in detail, it is to be understood that the invention is not limited in its application to the details of construction and the arrangement of components set forth in the following description or illustrated in the following drawings. The invention is capable of other embodiments and of being practiced or of being carried out in various ways. Also, it is to be understood that the phraseology and terminology used herein is for the purpose of description and should not be regarded as limiting. The use of "including," "comprising," or "having" and variations thereof herein is meant to encompass the items listed thereafter and equivalents thereof as well as additional items. Unless specified or limited otherwise, the terms "mounted," "connected," "supported," and "coupled" and variations thereof are used broadly and encompass both direct and indirect mountings, connections, supports, and couplings. Further, "connected" and "coupled" are not restricted to physical or mechanical connections or couplings.

[0016] Fig. 1 illustrates a fluid compression module 10 (sometimes referred to as a compression stage or a compression unit) that includes a prime mover, such as a motor 15 coupled to a compressor 20 and operable to produce a compressed fluid. In the illustrated construction, an electric motor 15 is employed as the prime mover. However, other constructions may employ other prime movers such as but not limited to internal combustion engines, diesel engines, combustion turbines, etc.

[0017] The electric motor 15 includes a rotor 25 and a stator 30 that defines a stator bore 35. The rotor 25 is supported for rotation on a shaft 40 and is positioned substantially within the stator bore 35. The illustrated rotor 25 includes permanent magnets 45 that interact with a magnetic field produced by the stator 30 to produce rotation of the rotor 25 and the shaft 40. In a preferred construction, the rotor is operable at a speed in excess of 50,000 RPM, with faster and slower speeds also being possible. The magnetic field of the stator 30 can be varied to vary the speed of rotation of the shaft 40. Of course, other constructions may employ other types of electric motors (e.g., synchronous, induction, brushed DC motors, etc.) if desired.

[0018] The motor 15 is positioned within a housing 50 which provides both support and protection for the motor 15. A bearing 55 is positioned on either end of the housing 50 and is directly or indirectly supported by the housing 50. The bearings 55 in turn support the shaft 40 for rotation. In the illustrated construction,

magnetic bearings 55 are employed with other bearings (e.g., roller, ball, needle, etc.) also suitable for use. In the construction illustrated in Fig. 1, secondary bearings 60 are employed to provide shaft support in the event one or both of the magnetic bearings 55 fail.

[0019] In some constructions, an outer jacket 65 surrounds a portion of the housing 50 and defines cooling paths 70 therebetween. A liquid (e.g., glycol, refrigerant, etc.) or gas (e.g., air, carbon dioxide, etc.) coolant flows through the cooling paths 70 to cool the motor 15 during operation.

[0020] An electrical cabinet 75 may be positioned at one end of the housing 50 to enclose various items such as a motor controller, breakers, switches, and the like. The illustrated embodiment includes a controller 76. The motor shaft 40 extends beyond the opposite end of the housing 50 to allow the shaft to be coupled to the compressor 20.

[0021] The compressor 20 includes an intake housing 80 or intake ring, an impeller 85, a diffuser 90, and a volute 95. The volute 95 includes a first portion 100 and a second portion 105. The first portion 100 attaches to the housing 50 to couple the stationary portion of the compressor 20 to the stationary portion of the motor 15. The second portion 105 attaches to the first portion 100 to define an inlet channel 110 and a collecting channel 115. The second portion 105 also defines a discharge portion 120 that includes a discharge channel 125 that is in fluid communication with the collecting channel 115 to discharge the compressed fluid from the compressor 20.

[0022] In the illustrated construction, the first portion 100 of the volute 95 includes a leg 130 that provides support for the compressor 20 and the motor 15. In other constructions, other components are used to support the compressor 20 and the motor 15 in the horizontal position. In still other constructions, one or more legs, or other means are employed to support the motor 15 and compressor 20 in a vertical orientation or any other desired orientation.

[0023] The diffuser 90 is positioned radially inward of the collecting channel 115 such that fluid flowing from the impeller 85 must pass through the diffuser 90 before entering the volute 95. The diffuser 90 includes aerodynamic surfaces 135 (e.g., blades, vanes, fins, etc.), shown in Fig. 2, arranged to reduce the flow velocity and increase the pressure of the fluid as it passes through the diffuser 90.

[0024] The impeller 85 is coupled to the rotor shaft 40 such that the impeller 85 rotates with the motor rotor 25. In the illustrated construction, a rod 140 threadably engages the shaft 40 and a nut 145 threadably engages the rod 140 to fixedly attach the impeller 85 to the shaft 40. The impeller 85 extends beyond the bearing 55 that supports the motor shaft 40 and, as such is supported in a cantilever fashion. Other constructions may employ other attachment schemes to attach the impeller 85 to the shaft 40 and other support schemes to support the impeller 85. As such, the invention should not be limited to the construction illustrated in Fig. 1. Furthermore, while the illustrated construction includes a motor 15 that is directly coupled to the impeller 85, other constructions may employ a speed increaser such as a gear box to allow the motor 15 to operate at a lower speed than the impeller 85

[0025] The impeller 85 includes a plurality of aerodynamic surfaces or blades 150 that are arranged to define an inducer portion 155 and an exducer portion 160. The inducer portion 155 is positioned at a first end of the impeller 85 and is operable to draw fluid into the impeller 85 in a substantially axial direction. The blades 150 accelerate the fluid and direct it toward the exducer portion 160 located near the opposite end of the impeller 85. The fluid is discharged from the exducer portion 160 in at least partially radial directions that extend 360 degrees around the impeller 85.

[0026] The impeller 85 cooperates with a stationary seal ring 162 to define a seal. The seal is positioned to reduce the axial force applied to the back face of the impeller 85, thereby reducing the overall axial thrust toward the blades 150. The thrust is reduced to a level that allows for the use of an active magnetic thrust bearing 163 rather than a more conventional thrust bearing. The magnetic thrust bearing 163 includes a thrust disc 164 having a reduced diameter as compared to that which would be necessary absent the aforementioned seal system.

[0027] The intake housing 80, sometimes referred to as the intake ring, is connected to the volute 95 and includes a flow passage 165 that leads to the impeller 85. Fluid to be compressed is drawn by the impeller 85 down the flow passage 165 and into the inducer portion 155 of the impeller 85. The flow passage 165 includes an impeller interface portion 170 that is positioned near the blades 150 of the impeller 85 to reduce leakage of fluid over the top of the blades 150. Thus, the impeller 85 and the intake housing 80 cooperate to define a plurality of substantially closed flow passages 175.

[0028] In the illustrated construction, the intake housing 80 also includes a flange 180 that facilitates the attachment of a pipe or other flow conducting or holding component. For example, a filter assembly could be connected to the flange 180 and employed to filter the fluid to be compressed before it is directed to the impeller 85. A pipe would lead from the filter assembly to the flange 180 to substantially seal the system after the filter and inhibit the entry of unwanted fluids or contaminants.

[0029] Turning to Fig. 2, the impeller 85 is illustrated in greater detail. The inducer portion 155 is substantially annular and draws fluid along an intake path 185 into the impeller 85. The fluid enters in a substantially axial direction and flows through the passages 175 defined between adjacent blades 150 to the exducer portion 160.

[0030] Fig. 3 illustrates the compression system or module 10 of Figs. 1 and 2 in perspective. The flange 180 connects to a filter or other source of clean fluid to receive the fluid to be compressed. In addition, a second flange 190 is connectable to a pipe, a receiver, or other fluid handling device to receive the compressed fluid from the compression module 10. If the illustrated module 10 were the second stage of a three-stage compression system, the outlet of the first stage would be connected to the flange 180 to deliver the partially compressed fluid. After further compression, the fluid would be discharged from the second flange 190 and would flow to the inlet of the third stage.

[0031] Fig. 4 illustrates another compression module 195 in an alternative orientation. Specifically, the compression module 195 of Fig. 4 is supported in a vertical orientation and is similar to the construction of Fig. 3 except for the support structure. The construction of Fig. 4 includes three legs 200 that support the compression module 195. Of course other constructions may include other support systems and may support the compression system 195 in a different orientation if desired.

[0032] Fig. 5 illustrates a series of compression modules 10a, 10b, 10c arranged to define a multi-stage compressor 205. Fig. 5 illustrates each compression module 10a, 10b, 10c as being similar to the compression module 10 of Figs. 1-3. However, other constructions may employ the compression modules 195 of Fig. 4, may mix the compression modules 10, 195 of Figs. 3 and 4, or use different modules altogether.

[0033] For purposes of description, Fig. 5 will be described using air as the fluid being compressed. Of course one of ordinary skill in the art will realize that many other fluids can be compressed using the present system. The first module 10a draws in a flow of air 210 in an uncompressed state and discharges a flow of partially-compressed air 215. The pressure of the air leaving the first module 10a is determined by the inlet pressure and the pressure ratio of the first module 10a. For example, if air enters the first module 10a at a pressure of one atmosphere and the compressor operates at a pressure ratio of 2.5, the air will exit the first module 10a at a pressure of about 2.5 atmospheres.

[0034] The partially compressed air 215 flows to an inter-stage heat exchanger 220 that cools the partially compressed air 215 to improve the overall compression system efficiency. In the illustrated, construction, a cooling fluid 225 (e.g., cool air, water, glycol, refrigerant, etc.) flows through the heat exchanger 220 to cool the air 215.

[0035] A cooled partially compressed air 230 flows into the inlet of the second stage 10b of the multi-stage compression system 205. The second stage compression module 10b further compresses the air and discharges a second flow of partially compressed air 235. Again, the discharge pressure is largely a function of the inlet pressure and the pressure ratio of the second module 10b. Continuing the above example, if the air enters the second module 10b at 2.5 atmospheres and the second module 10b has a pressure ratio of 2, the discharge pressure will be about 5 atmospheres.

[0036] The second flow of partially compressed air 235 flows through a second inter-stage heat exchanger 240 where the air is again cooled by a coolant 245 that flows through the heat exchanger 240. After passing through the second inter-stage heat exchanger 240, the partially compressed air 250 proceeds to the third stage 10c of compression.

[0037] The third stage module 10c receives the partially compressed air 250 at the inlet and is operable to further compress the air to the final desired output pressure. The air is discharged 255 from the third stage module 10c at the desired output pressure. As with the first two stages 10a, 10b, the output pressure is a function of the pressure ratio and the inlet pressure. Thus, finishing the above example, if the air enters the third module 10c at a pressure of 5 atmospheres and

the pressure ratio of the last compressor is 4, the final output pressure will be about 20 atmospheres.

[0038] A final inter-stage cooler 260 may be employed following the final stage of compression to cool the air before the air is directed to additional systems (e.g., filters, dryers, etc.) or to a point of use. As with the other heat exchangers 220, 240, a flow of coolant 265 is used to cool the air before the air is discharged as the final flow of compressed air 270. While Fig. 5 illustrates a three-stage system 205 employing a single compressor at each stage, the present system is well suited in systems that employ more than two or more stages. In addition, some arrangements may include multiple compressors at one or more of the stages to increase the capacity of the system. The multiple compressors at a given stage may be operated independently or may be operated in unison if desired. As such, the invention should not be limited to a three stage system that employs only a single compressor at each stage.

[0039] As one of ordinary skill will realize, the pressure ratio of the three stage system 205 of Fig. 5 is greater than the pressure ratio of any one stage 10a, 10b, 10c. In the example of above, the pressure ratio of the three-stage compression system 205 is about twenty to one. Of course, other systems will have different pressure ratios depending on the desired use or application of the fluid being compressed.

[0040] Fig. 6 is a schematic illustration of one possible control arrangement 275 suitable for use with the multi-stage system 205 illustrated in Fig. 5. Each motor 15a, 15b, 15c includes a motor controller 275a, 275b, 275c that directly controls the speed of the attached motor 15a, 15b, 15c. A system controller 280 is connected to each motor controller 275a, 275b, 275c and provides control signals 285 to each motor controller 275a, 275b, 275c to control the speed of the motors 15a, 15b, 15c. A first sensor 290 is positioned to measure the output pressure of the multi-stage system 205 and provides a control signal 295 indicative of that pressure to the controller 280. While not illustrated, other sensors could also be employed to send data to the controller 280. The data could be used for controlling the motors 15a, 15b, 15c or could simply be monitored.

[0041] The control scheme 275 illustrated in Fig. 6 allows for the individual control of the speed of each motor 15a, 15b, 15c. Thus, each motor 15a, 15b, 15c can be operated at a speed that is suitable for the compressor 20a, 20b, 20c, while

still providing fluid at the desired pressure and volumetric flow rate. During periods of operation in which the operating conditions are not ideal, each motor 15a, 15b, 15c can be adjusted to run at a speed that produces a suitable flow rate and pressure ratio at the compressor 20a, 20b, 20c, while simultaneously providing the desired conditions for the output fluid.

[0042] It can be advantageous to allow motor speeds to differ, to improve efficiency of operation and also to determine when an individual compressor 20a, 20b, 20c is not operating as it should and possibly needs replacement.

[0043] Fig. 7 schematically illustrates multiple compression modules 295a, 295b, including multiple variable speed electric motors 300a, 300b. The first compression module 295a includes a first motor 300a driving two compressors 305a, 305b and the second compression module 295b includes the second motor 300b and a single compressor 305c driven by the second motor 300b. The two compressors 305a, 305b of the first compression module 295a could be positioned in series as illustrated in Fig. 7 or could be arranged in parallel to increase the capacity of the first stage of compression.

[0044] In operation, each motor 15 is powered by the electrical cabinet 75 and controller 76 which rotates the rotor 25 and shaft 40 and ultimately causes impeller aerodynamic surfaces 150 to rotate. This draws fluid into a first compressor 20 via intake path 185 at atmospheric pressure and out through discharge portion 120 at a higher pressure. In multiple stage embodiments, the compressed fluid is sent through a heat exchanger 220, 240, 260 which removes some of the heat that has been produced by compressing the fluid. This cooled fluid is then drawn into a second compressor 20 and to any number of desired additional stages to allow for different pressures of fluid to be available for use, or to attain a greater pressure than would normally be possible by a single compressor.

[0045] The controller 280 includes information about compressed gas temperatures and pressures, positions of valves, stability margin of the compressor 20a, 20b, 20c, requirements of the system upstream the compressor 20a, 20b, 20c, and performance parameters of the auxiliary systems. The speed of each motor 15a, 15b, 15c is controlled and varied by the controller 280 in response to the desired output pressure, ambient temperature and pressure, fluid temperature and other relevant variables as may be required. For example, one construction includes a pressure sensor and a velocity sensor at the outlet of each compression stage. The

pressure and velocity are used to determine the volumetric flow rate of the stage and the pressure is used to determine the pressure ratio. These values are then applied to a compressor map, along with the speed of the compressor, to determine if the compressor has sufficient surge margin and choke margin. Each stage of compression is optimized to run efficiently, with sufficient margins, and at a speed that allows for the output of compressed fluid having the desired characteristics (e.g., pressure, flow rate, etc.).

[0046] The use of a high-speed motor 15a, 15b, 15c directly coupled to the centrifugal compressor 20a, 20b, 20c eliminates the required gearing and related oil lubrication requirements of a non-directly connected system. In recent years, high-speed motor technology, as applied to oil-free air centrifugal compressors, has evolved considerably. Active magnetic bearings which levitate the shaft in air are the bearing system often utilized in high-speed electric motors, since they introduce a significant power loss advantage with respect to the application of conventional fluid-film hydrodynamic bearings.

[0047] The development of an industrial multistage centrifugal compressor system 205 with independently directly driven compressor modules 10a, 10b, 10c is advantageous because of the de-coupling between the speed, the location, and the operating mode of the stages of compression 10a, 10b, 10c. Furthermore, high-speed synchronous electric motors 15a, 15b, 15c are operable to vary the rotational speed of the compressor stages 10a, 10b, 10c and can satisfy, in terms of overall compressor stability and overall power consumption, the demand of the downstream process.

[0048] The de-coupling of the drive member, and therefore the speed, location, and operation of the various stages also eliminates the need for a conventional inlet valve and can eliminate the need for dump valves and other flow control systems that are typically used to avoid operating one or more stages near the surge limit. The elimination of these features reduces the cost and complexity of the system and improves the overall efficiency.

[0049] It should also be noted that the design of the impeller 85 as well as the shaft 40 and the active magnetic bearings 55 is such that the rotating assembly operates below its first critical speed under all normal operating conditions. The sub-critical operation is achieved by providing a light yet stiff rotating assembly. To

achieve this, the impeller 85 is compact for its size and is formed using a light yet strong material (e.g., titanium alloys, aluminum, etc.).

[0050] Various features and advantages of the invention are set forth in the following claims.

CLAIMS

What is claimed is:

1. A multi-stage fluid compression system comprising:
 - a first centrifugal compressor stage having a first inlet and a first outlet;
 - a second centrifugal compressor stage having a second inlet and a second outlet, the second inlet receiving a flow of compressed fluid from the first outlet;
 - a first variable-speed motor coupled to the first centrifugal compressor stage and operable to drive the first centrifugal compressor stage at a first speed; and
 - a second variable speed motor coupled to the second centrifugal compressor stage and operable to drive the second centrifugal compressor stage at a second speed, the first speed and the second speed each being independently variable.

2. The multi-stage fluid compression system of claim 1, wherein one of the first centrifugal compressor stage and the second centrifugal compressor stage includes a first shaft that supports a first impeller and a second impeller, and the other of the first centrifugal compressor stage and the second centrifugal compressor stage includes a second shaft that supports a single third impeller.

3. The multi-stage fluid compression system of claim 1, wherein the first centrifugal compressor stage includes a first shaft that supports a first impeller and a second impeller, and the second centrifugal compressor stage includes a second shaft that supports a third impeller and a fourth impeller.

4. The multi-stage fluid compression system of claim 1, further comprising a heat exchanger configured to receive the flow of compressed fluid from the first outlet and deliver the flow to the second inlet.

5. The multi-stage fluid compression system of claim 1, further comprising a control system operable to control the speed of each of the motors independently.

6. The multi-stage fluid compression system of claim 5, further comprising at least one sensor associated with the first centrifugal compressor stage and at least one sensor associated with the second centrifugal compressor stage, the control system operable to determine an output flow rate and an output pressure of the first centrifugal compressor stage and the second centrifugal compressor stage based at least partially on the data sensed by the sensors.

7. The multi-stage fluid compression system of claim 6, wherein at least one of the sensors measures a pressure and at least one of the sensors measures a velocity.

8. The multi-stage fluid compression system of claim 1, further comprising a first motor controller operable to control the speed of the first motor and a second motor controller operable to control the speed of the second motor.

9. The multi-stage fluid compression system of claim 1, further comprising an active magnetic thrust bearing coupled to the first centrifugal compressor and operable to support the thrust load of the first centrifugal compressor.

10. The multi-stage compression system of claim 1, wherein each motor includes a shaft that rotates at a speed that is greater than or equal to about 50,000 RPM.

11. A multi-stage compression system comprising:
 - a plurality of centrifugal compressor units, each compressor unit having an inlet and an outlet, a first of the compressor units drawing in a fluid at a first pressure and a last of the compressor units discharging the fluid at a second pressure;
 - a plurality of variable-speed motors, each of the motors directly driving one of the plurality of compressor units, each motor operable at a speed between a motor minimum and a motor maximum independent of the other motors; and
 - a control system operable to vary the speed of each motor independently at least partially in response to the second pressure.
12. The multi-stage compression system of claim 11, wherein each of the plurality of centrifugal compressor units includes a shaft that supports a first impeller for rotation, and wherein at least one of the shafts supports a second impeller in addition to the first impeller.
13. The multi-stage fluid compression system of claim 11, further comprising a plurality of heat exchangers, each heat exchanger disposed between the outlet and the inlet of adjacent centrifugal compressor units.
14. The multi-stage fluid compression system of claim 11, further comprising a control system operable to control the speed of each of the motors independently.
15. The multi-stage fluid compression system of claim 14, further comprising a plurality of sensors, each sensor associated with at least one of the centrifugal compressor units, the control system operable to determine an output flow rate and an output pressure of each of the centrifugal compressor units based at least partially on the data sensed by the sensors.
16. The multi-stage fluid compression system of claim 15, wherein at least one of the sensors associated with each compressor unit measures a pressure and at least one of the sensors associated with each compressor unit measures a velocity.

17. The multi-stage fluid compression system of claim 11, further comprising a plurality of motor controllers, each operable to control the speed of one of the plurality of motors.

18. The multi-stage compression system of claim 11, further comprising a plurality of active magnetic thrust bearings, each magnetic thrust bearing coupled to one of the plurality of centrifugal compressor units and operable to support the thrust load of the associated centrifugal compressor unit.

19. The multi-stage compression system of claim 11, wherein each motor includes a shaft that rotates at a speed that is greater than or equal to about 50,000 RPM.

20. The multi-stage compression system of claim 19, further comprising a plurality of impellers, each impeller coupled to one of the shafts, each shaft supported for rotation by at least two active magnetic bearings.

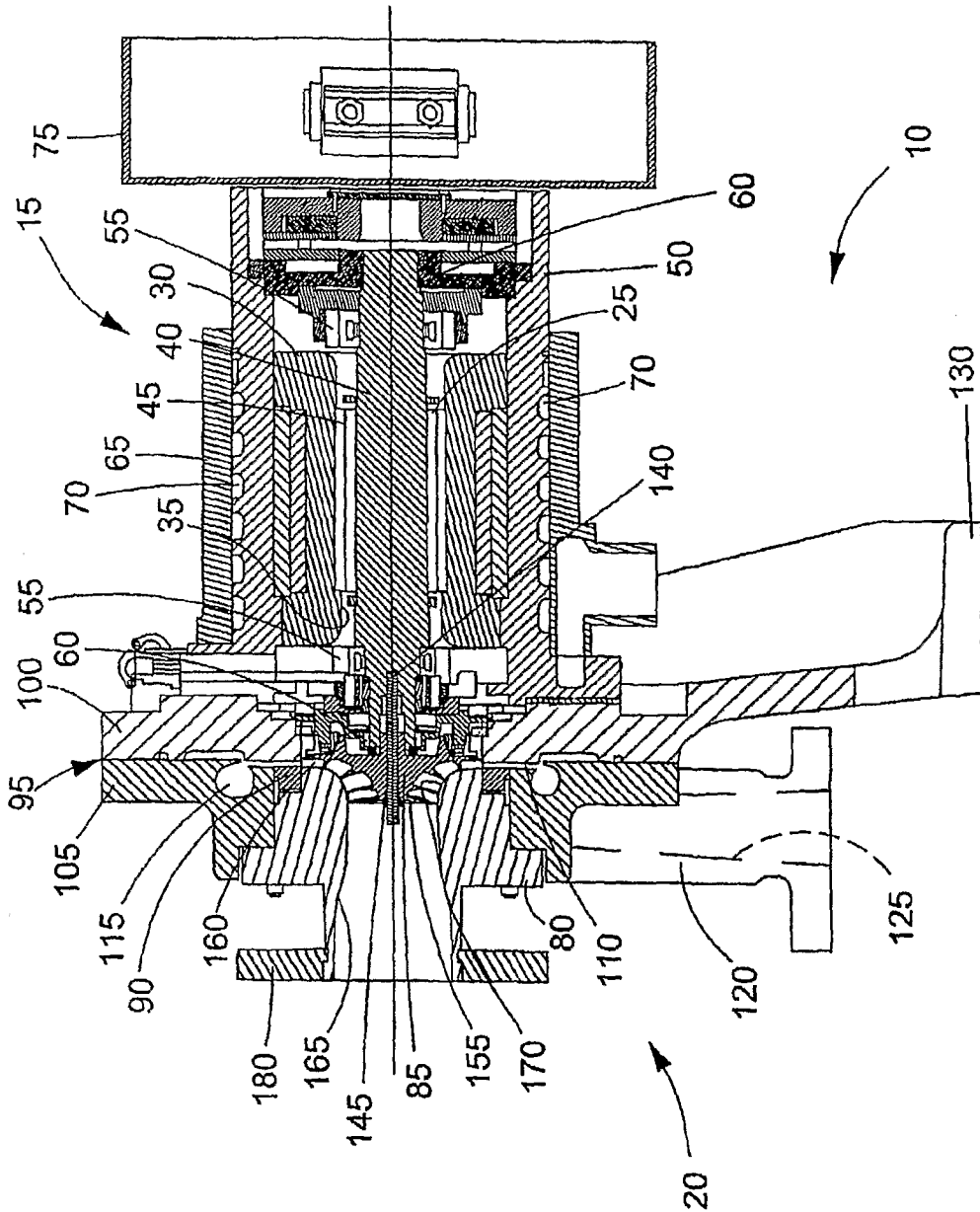

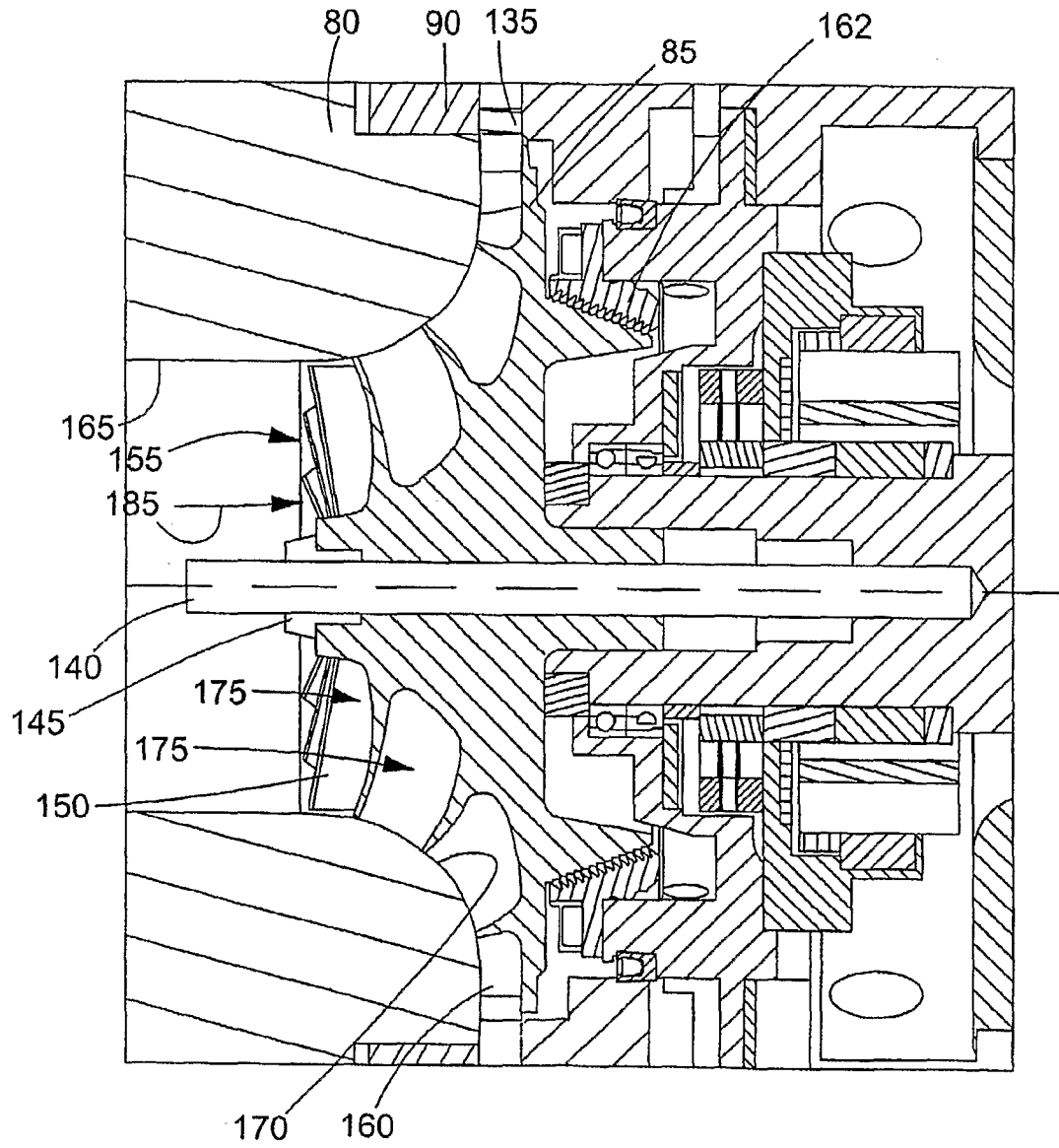

FIG. 2

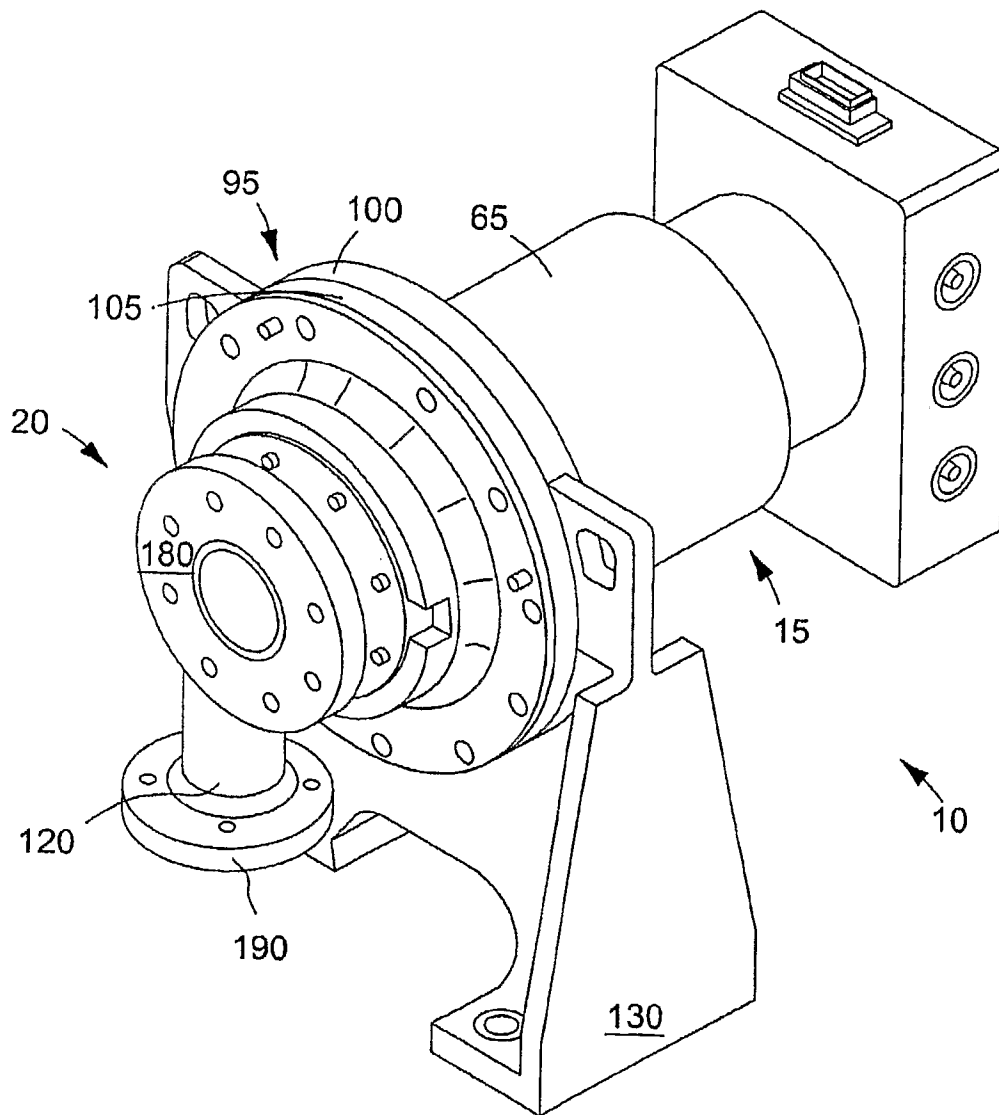

FIG. 3

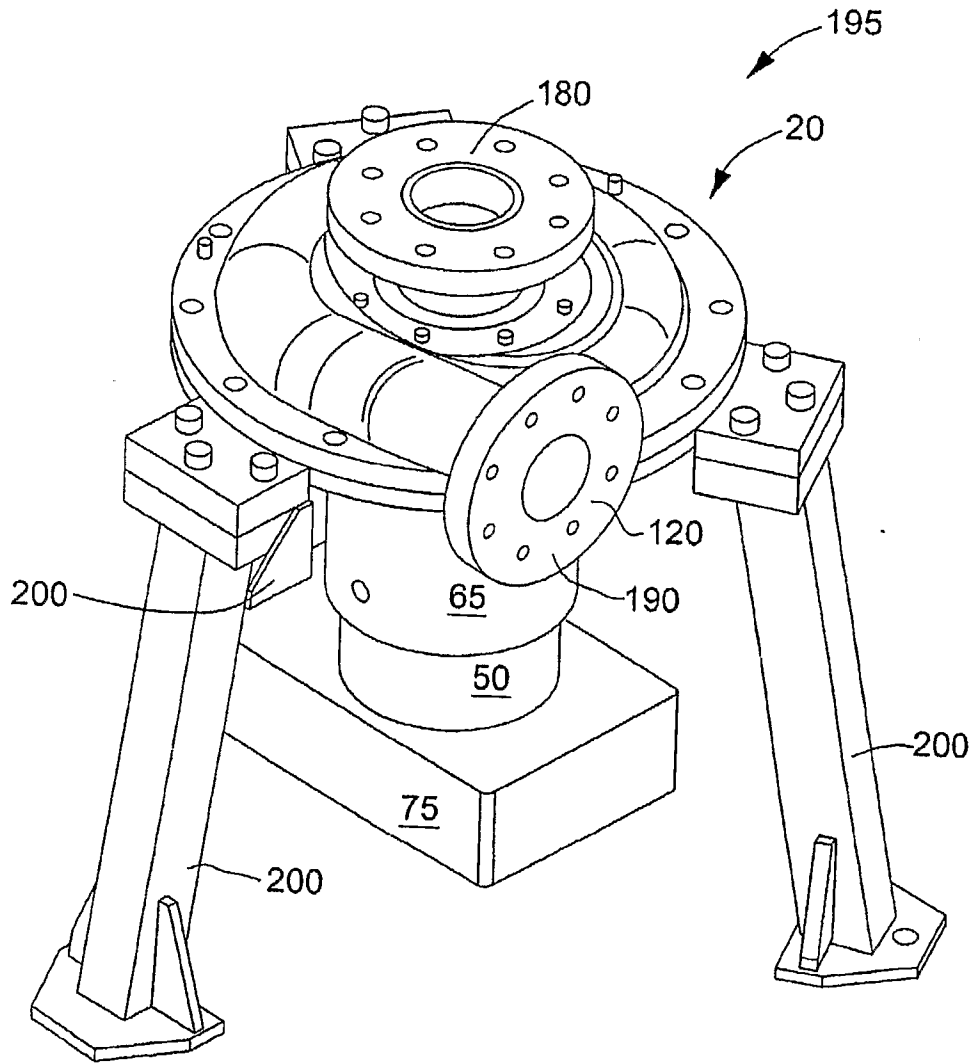
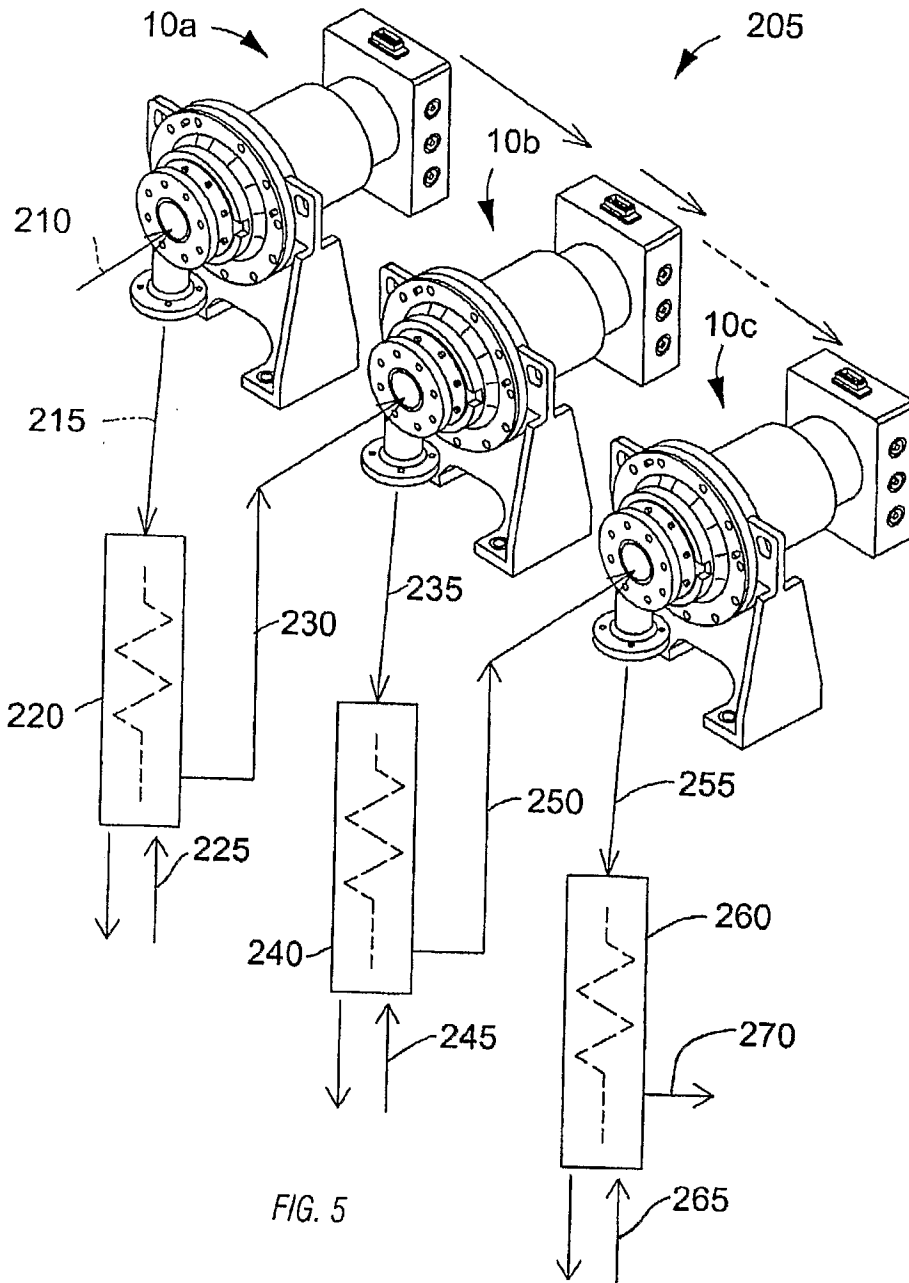

FIG. 4



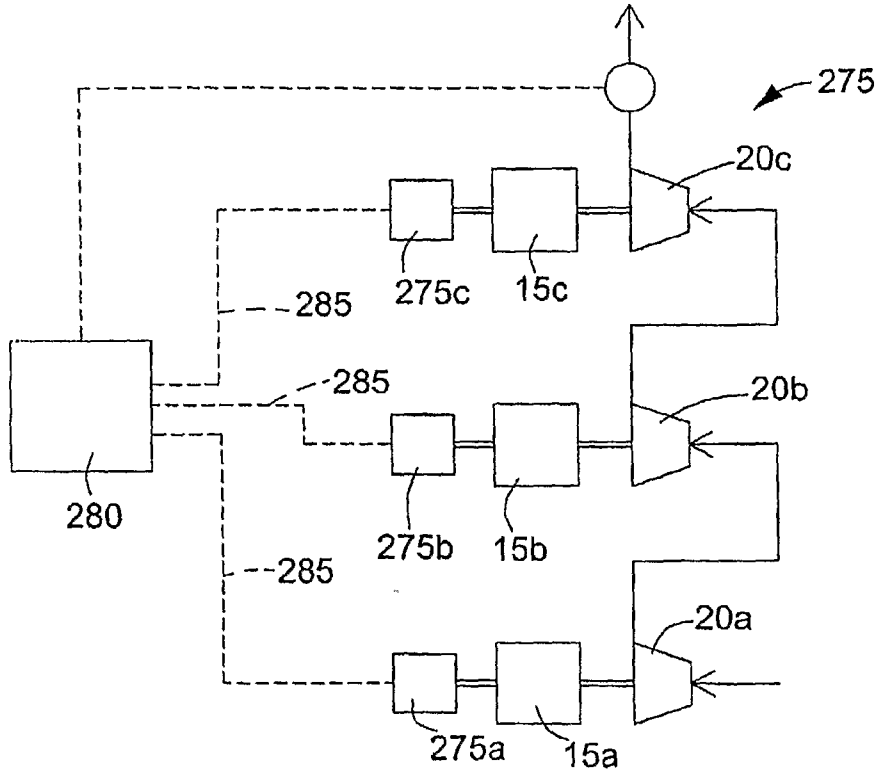

FIG. 6

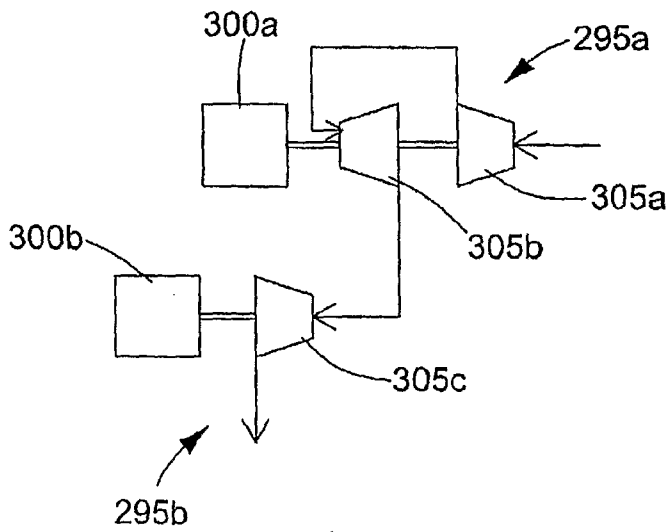

FIG. 7