

(19) **DANMARK**

(10) **DK/EP 3168542 T3**



Patent- og  
Varemærkestyrelsen

(12) **Oversættelse af  
europæisk patentskrift**

- 
- (51) Int.Cl.: **F 24 F 5/00 (2006.01)** **F 24 D 3/14 (2006.01)**
- (45) Oversættelsen bekendtgjort den: **2020-06-29**
- (80) Dato for Den Europæiske Patentmyndigheds bekendtgørelse om meddelelse af patentet: **2020-04-22**
- (86) Europæisk ansøgning nr.: **16197957.0**
- (86) Europæisk indleveringsdag: **2016-11-09**
- (87) Den europæiske ansøgnings publiceringsdag: **2017-05-17**
- (30) Prioritet: **2015-11-12 DE 202015106131 U**
- (84) Designerede stater: **AL AT BE BG CH CY CZ DE DK EE ES FI FR GB GR HR HU IE IS IT LI LT LU LV MC MK MT NL NO PL PT RO RS SE SI SK SM TR**
- (73) Patenthaver: **Uponor Innovation AB, P.O. Box 101, 73061 Virsbo, Sverige**
- (72) Opfinder: **Llorente, Raul, Schützenstr. 36, 96047 Bamberg, Tyskland**  
**Lipinski, Johann, Jägerstraße 17, 22926 Ahrensburg, Tyskland**
- (74) Fuldmægtig i Danmark: **Zacco Denmark A/S, Arne Jacobsens Allé 15, 2300 København S, Danmark**
- (54) Benævnelse: **Fladetempereringssystem, varmevekslerindretning, fremgangsmåde samt monteringsfremgangsmåde**
- (56) Fremdragne publikationer:  
**JP-A- 2008 122 014**  
**JP-A- 2009 052 778**  
**US-B1- 6 533 185**



## Description

The present invention relates to an area temperature control system for cooling or heating ceilings, walls or floors of a building. The invention further relates to a heat exchanger arrangement with such an area temperature control system.

Area temperature control systems are well known from the state of the art. In contrast to conventional systems, area temperature control systems allow room and component surfaces such as floors, walls and ceilings to be used for both heating and cooling. Such systems make it possible, for example, to heat a room in winter and cool it in summer, using essentially the same technology. For heat transfer, area temperature control systems typically use pipelines through which a medium flows. Such area temperature control systems allow an efficient use of rooms because the entire system is integrated in floors, walls or ceilings. Furthermore, area temperature control systems not only allow installation in new buildings, but also subsequent installation in old buildings.

One task of the present invention is to specify a concept for area heating and cooling systems which contributes to flexible handling and easy installation.

An area temperature control system for cooling or heating the ceilings, walls or floors of a building is disclosed. The area temperature control system has an installation plate in which at least one pipe guiding channel, open towards an upper side of the installation plate, is incorporated. Furthermore, two heat conducting foils are provided, which are applied to the upper side of the installation plate in such a way that the two heat conducting foils overlap at least along a portion of the pipe guiding channel, so that, when a pipe is later inserted into the pipe guiding channel, the heat conducting foils are pressed into the pipe guiding channel along the portion and at least partially line it.

Such a surface temperature control system is very flexible and manageable and is particularly easy to install. In particular, only two heat conducting foils need to be laminated onto the installation plate so that they overlap at least along the section of the pipe guiding channel. In other words, an overlap area is created in an area of the pipe guiding channel that is open at the top. In particular, the overlap area is above the opening of the pipe guiding channel. An overlap area is, for example, the area where two foils lie on top of each other. A degree of overlap, such as an extension or dimension of

the overlap area, is selected so that when a pipe is inserted into the pipe guiding channel, the heat conducting foils in the overlap area are pressed into the pipe guiding channel.

5 By pressing into the pipe guiding channel, a large-area contact between the pressed-in pipe and the heat conducting foil can be created, depending on the selected degree of overlap. In other words, the pipe in the inserted state is surrounded over a large area by the two heat conducting foils. This contributes to an effective heat transfer from the pipe to the heat conducting foil, so that the heat or cold radiated by the pipe is distributed over a large area over the heat conducting foils of the installation board. It was recognised that  
10 such a surface temperature control system can be manufactured particularly easily. Only two heat conducting foils have to be provided, which are overlapped and applied to the installation panel. When applying the two heat conducting foils, tolerances in the lamination can be compensated. In other words, the application of the two heat conducting foils does not have to be done with the highest precision.

15 During pipe insertion, parts of the heat conducting foils are pushed or pressed into the pipe guiding channel. The insertion of the pipe can be done in a simple way. Essentially, no special force is required to press in the two heat conducting foils, as they are not joined together in the overlap area. Thus, for example, no force needs to be applied to cut  
20 through a single foil that completely covers the pipe guiding channel. This also applies in the case of a perforated foil that completely covers a pipe guiding channel, since forces are also required to tear the foil along the perforation. Furthermore, this helps to ensure that a uniform, predetermined lining of the pipe guiding channel is always achieved. If the foil were to tear, it would not be predictable or only to a limited extent.

25 A further advantage is that the degree of overlap can be used to determine which areas of the pipe guiding channel are to be lined. This is not possible if only a single foil is used to cover the entire pipe guiding channel, with or without perforation, as only the part of the foil covering the pipe guiding channel is available for lining. The disadvantage of a single  
30 foil would often be that only a small area or even only linear contact with the pipe would be achieved, which results in a reduced efficiency for heating or cooling compared to the system described.

It should be noted at this point that in various designs, several pipe guiding channels and  
35 correspondingly several heat conducting foils are provided, two of which overlap at least

in sections along one of the pipe guiding channels. Such designs do not deviate from the described principle of the area temperature control system.

According to a further embodiment, the heat conducting foils overlap in such a way that, after the heat conducting foils have been pressed into the pipe guiding channel, an area of the pipe guiding channel remains free of heat conducting foils. The area means, for example, a part or section of an inner wall or inner surface of the pipe guiding channel. In this area of the pipe guiding channel, there is no foil between the inner surface of the installation plate and the pipe.

According to an embodiment the pipe guiding channel has a circumference and the area is arranged around a center of the circumference.

A free area of the pipe guiding channel ensures, for example, that an area of a circumference of the pipe guiding channel remote from the upper side of the installation plate is not covered with a heat conducting foil. In other words, this makes it possible to keep a floor area of the pipe guiding channel free of heat conducting foils. This helps to ensure that the heat or cold emitted by the pipe is distributed particularly effectively in the heat conducting foils over the top of the installation board. There is practically no or only little heat exchange via the bottom of the pipe guiding channel into the interior of the installation board. This contributes to an efficient area temperature control system. In particular, such an area temperature control system does not or only slightly deteriorate in terms of efficiency in heat exchange for heating or cooling rooms compared to systems with a fully lined pipe guiding channel. However, such a fully lined pipe guiding channel is typically equipped with a pre-punched and/or pre-stamped plate instead of the heat conducting foil, which has significant cost disadvantages compared to the solution described.

According to an embodiment each heat conducting foil has an overlapping portion bounded by an edge of the heat conducting foil, with both overlapping portions being pressed into the pipe guiding channel when the pipe is inserted. The pipe guiding channel is defined towards the top by two edges of the installation panel. When the heat conducting foil is pressed into the pipe guiding channel, one heat conducting foil is bent inwards around one edge and the other heat conducting foil around the other edge and is essentially adapted to the inner shape of the channel. When pressing in, each overlap section is pressed in on one side of the pipe guiding channel. In this way, for example, an

area of the pipe guiding channel defined between the edges of the overlap sections can remain free of heat conducting foils.

5 According to an embodiment the overlapping portions overlap in a predetermined manner such that each overlapping portion lines at least one third of the circumference of the pipe guiding channel. This ensures in particular a very effective heat exchange between an inserted pipe and the two heat conducting foils, whereby in particular, as described above, an area of the pipe guiding channel remaining free between the two edges of the heat conducting foils is not covered with heat conducting foils.

10

According to an embodiment the pipe guiding channel is formed as a semi-cylindrical recess in the installation plate. This allows the foils to be pressed into the pipe guiding channel particularly easily and gently. In particular, sharp edges or contour transitions can be avoided, which could damage the heat conducting foils.

15

According to a further embodiment the pipe guiding channel extends in a straight line. This ensures a particularly simple production of the area temperature control system.

20 According to an embodiment the heat conducting foils are formed as strips. This contributes to a particularly simple production of the area temperature control system. In particular, the heat conducting foils must be applied at right angles to the installation plate together with straight pipe guiding channels.

25 According to a further embodiment the installation plate is formed as an insulating board. The insulation board serves to insulate heat or cold. EPS, PU, wood wool or other insulation materials are particularly suitable for the insulation board.

30 According to a further embodiment the heat conducting foils are made of an aluminium material or a graphite material.

35

Furthermore, a heat exchanger arrangement is revealed which has an area temperature control system according to one of the designs described above. Furthermore, the heat exchanger arrangement has a pipe through which a medium for cooling and/or heating can flow. The area temperature control system has an installation plate in which at least one pipe guiding channel open towards an upper side of the installation plate is inserted. Furthermore, two heat conducting foils are provided, which are applied to the upper side

of the installation plate in such a way that the two heat conducting foils overlap along the pipe guiding channel. The pipe is inserted into the pipe guiding channel in such a way that the heat conducting foils are at least partially pressed into the pipe guiding channel and at least partially line it.

5

The heat exchanger arrangement essentially enables the above-mentioned advantages and functions.

Furthermore, a method for manufacturing such an area temperature control system is disclosed. The method comprises the steps:

10

- providing an installation plate;
- incorporating at least one pipe guiding channel, open to an upper side of the installation plate; and
- applying two heat conducting foils to the upper side of the installation plate in such a way that said heat conducting foils overlap along the pipe guiding channel at least in one portion.

15

Furthermore, an assembly method for producing a heat exchanger assembly is disclosed. The assembly method comprises the steps:

20

- providing an area temperature control system according to a described embodiment;
- inserting a pipe into the pipe guiding channel in such a way that the heat conducting foils are at least partially pressed into the pipe guiding channel and at least partially line it.

25

The method for manufacturing an area temperature control system as well as the assembly method essentially enable the above-mentioned advantages and functions.

Further advantages and functions are described in the subclaims and the following detailed description of embodiments of the invention.

30

The embodiments of the invention are described below with the aid of the attached figures.

35 The figures show:

Figure 1 a schematic cross-sectional view of an area heating and cooling system,

Figure 2 is a schematic cross-sectional view of a heat exchanger assembly with the area heating system, and

5

Figure 3 shows another schematic cross-sectional view of the area heating and cooling system.

Figure 1 shows a schematic cross-sectional view of an area temperature control system 1.

10 The area temperature control system 1 has an installation plate 2 made of foam plastic. The installation plate 2 is an insulation board. The foamed plastic according to the embodiment is EPS (expanded polystyrene). Alternatively, other materials such as mineral or wood fibre boards can also be used. The installation plate 2 has an upper side 3. A pipe guiding channel 4 is inserted into the installation panel 2, which is open towards  
15 the top side 3. The pipe guiding channel 4 has a cylindrical design and serves to accommodate a pipe through which a medium such as water for cooling and/or heating flows. Two heat conducting foils 5 and 6 are laminated onto the upper side 3. The heat conducting foils 5 and 6 are made of an aluminium material. Alternatively, other thermally conductive materials can be used, such as graphite. The pipe guiding channel 4 is limited  
20 on the upper side 3 by two opposite edges 7. The edges 7 define the course of the pipe guiding channel 4 (not shown).

The two heat conducting foils 5 and 6 are each applied to the installation plate 2 in such a way that they partially overlap both themselves and the pipe guiding channel 4. Each of  
25 the heat conducting foils 5 and 6 has an overlapping section 8. The overlapping sections 8 of the two heat conducting foils 5 and 6 are each bordered by an edge 10. The overlap section 8 of a heat conducting foil 5, 6 corresponds to the section extending from an edge 7 to the edge 10 of the corresponding heat conducting foil 5, 6. In the design example, an overlap section 8 essentially corresponds to the distance between the two edges 7. The  
30 two heat conducting foils 5, 6 thus form an overlap area 9 along the pipe guiding channel 4. In the exemplary embodiment, the overlap area 9 of the two heat conducting foils 5 and 6 runs along the pipe guiding channel 4, i.e. in a direction normal to the image plane of figures 1 to 3 (not shown). In the exemplary embodiment, the two heat conducting foils 5 and 6 overlap along the entire pipe guiding channel 4 inserted in the installation plate 2. In  
35 alternative embodiments it is also conceivable that the heat conducting foils 5 and 6 overlap only in sections along a pipe guiding channel.

A pipe is inserted into the area temperature control system 1 for heating and cooling. This is shown in Figure 2, which represents a heat exchanger arrangement with the area temperature control system 1 shown in Figure 1.

5

Figure 2 shows a heat exchanger arrangement 20, which has an area temperature control system 1. The area temperature control system 1 is additionally provided with a screed 21, which is applied to the heat conducting foils 5 and 6. The screed 21 is for example cement screed (wet) or gypsum screed (dry). Alternatively, other material can be applied instead of screed 21. For example, parquet or tiles are applied to the installation plate 2, whereby an additional decoupling mat may be necessary. The heat exchanger arrangement 20 has a pipe 11, which is inserted into the pipe guiding channel 4.

10

The pipe 4 is pressed into the pipe guiding channel 4 according to the shape shown in Figure 1 in the overlap area 9. When pressed in, the overlap area 9 or the overlap sections 8 of the heat conducting foils 5 and 6 are pressed into the pipe guiding channel 4 and line it along a circumference 12 of the pipe guiding channel 4. This leaves an area 13 at the bottom of the pipe guiding channel 4 free of the heat conducting films. In other words, a lower area of the pipe guiding channel 4, which is furthest away from the top 3 of the installation plate 2, is free of the heat conducting foils 5, 6. When the heat conducting foils 5, 6 are pressed in, they are bent inwards along an edge 7 of the pipe guiding channel 4.

15

20

Depending on the degree of overlap, i.e. the design of the overlapping sections 8 and the arrangement of these on top of each other, it can be controlled which areas of the pipe guiding channel 4 are lined over its circumference 12. Thus, it can be specifically adjusted which inner surfaces or inner wall areas of the pipe guiding channel 4 are covered with the heat conducting foils 5, 6. The area 13 is preferably free, so that an insulation to the installation plate 2 is achieved above it.

25

30

Figure 3 shows in detail which parts of the pipe guiding channel 4 are lined with the heat conducting foils 5 and 6. For reasons of clarity, the area heating system 1 is shown without illustrating screed 21.

35

As already explained, the pipe guiding channel 4 essentially has a circular circumference 12. In relation to a centre point 14 of the pipe guiding channel 4, the heat conducting foils

5 and 6 each line a circular arc section of the pipe guiding channel 4, which is described with the angle  $\alpha$  or angle  $\beta$ . The remaining area 13 of the circumference 12 is described by the angle  $\gamma$  and is limited by the edges 10 of the heat conducting foils 5, 6. In the exemplary embodiment, the overlapping sections 8 are selected in such a way that they at least together line two thirds of the circumference 12 of the pipe guiding channel 4. If, instead of two heat conducting foils overlapping each other, only one heat conducting foil were provided to cover the top side 3 of the pipe guiding channel 4, only half of the pipe guiding channel 4 would be lined with heat conducting foil due to the geometric conditions, thus reducing heat transfer.

10

The described area temperature control system 1 or the heat exchanger arrangement 20 are particularly suitable for wet and/or dry floor installations, especially for pipe installations. As already mentioned at the beginning, several pipe guiding channels 4 and heat conducting foils 5, 6 of a installation plate 2 can be provided, which overlap the pipe guiding channels according to the described principle and are pressed in by means of the pipes.

15

In design examples not shown, the pipe guiding channel or channels run essentially straight and parallel to each other. Pipe guiding channels arranged next to each other can be connected at the ends by a curved section. In such a case, the heat conducting foils can be designed in stripes to overlap the straight sections of the pipe guiding channels. In this way, the heat conducting foils are easy to manufacture and can be easily applied to the installation plate, for example without much assembly and adjustment effort. The strips only have to be laminated onto the installation plate parallel to each other.

20

25

It should be noted at this point that instead of the exemplary screed 21 according to Figure 2, another material or material can also be applied to the area heating system 1.

## List of reference signs

- 1 area temperature control system
- 2 installation plate
- 5 3 top side
- 4 pipe guiding channel
- 5, 6 heat conducting foil
- 7 edge
- 8 overlap section
- 10 9 overlap area
- 10 edge
- 11 pipe
- 12 circumference
- 13 area
- 15 14 centre point
- $\alpha, \beta, \gamma$  angle
- 20 heat exchanger arrangement
- 21 screed

20

25

## Patentkrav

1. Fladetempereringssystem (1) til afkøling eller opvarmning af lofter, vægge eller gulve i en bygning, omfattende
- 5 - en installationsplade (2), i hvilken der er anbragt mindst en rørføringskanal (4), der er åben mod en overside (3) af installationspladen (2); og
- to varmeledningsfolier (5, 6), **kendetegnet ved, at** de to varmeledningsfolier (5, 6) er anbragt på oversiden (3) af installationspladen (4) på en sådan måde, at de to varmeledningsfolier (5, 6) overlapper hinanden i det mindste langs
- 10 med en sektion af rørføringskanalen (4), således at varmeledningsfolierne (5, 6) trykkes ind i rørføringskanalen (4) langs med sektionen og i det mindste delvist beklæder rørføringskanalen, når der senere indføres et rør (11) i rørføringskanalen.
- 15 **2.** Fladetempereringssystem (1) ifølge krav 1, hvor varmeledningsfolierne (5, 6) overlapper hinanden på en sådan måde, at der er et område (13) af rørføringskanalen (4), der forbliver frit for varmeledningsfolier (5, 6), efter at varmeledningsfolierne (5, 6) er blevet trykket ind i rørføringskanalen (4).
- 20 **3.** Fladetempereringssystem (1) ifølge krav 2, hvor rørføringskanalen (4) har en omkreds (12), og området (13) er anbragt omkring et centrum af omkredsen (12).
- 4.** Fladetempereringssystem (1) ifølge et af de foregående krav, hvor hver varmeledningsfolie (5, 6) har en overlappingssektion (8), der er afgrænset af en kant (10) af varmeledningsfolien (5, 6), hvor begge overlappingssektioner (8) trykkes ind i rørføringskanalen (4), når røret (11) indføres.
- 25 **5.** Fladetempereringssystem (1) ifølge krav 4, hvor overlappingssektionerne (8) overlapper hinanden på en forudbestemt måde således, at hver overlappingssektion (8) beklæder mindst en tredjedel af en omkreds (12) af rørføringskanalen (4).
- 30

- 6.** Fladetempereringssystem (1) ifølge et af de foregående krav, hvor rørføringskanalen (4) er udformet som en halvcylinderformet udsparring i installationspladen (2).
- 5      **7.** Fladetempereringssystem (1) ifølge et af de foregående krav, hvor rørføringskanalen (4) forløber i en lige linje.
- 8.** Fladetempereringssystem (1) ifølge et af de foregående krav, hvor varmeledningsfolierne (5, 6) er udformet som strimler.
- 10      **9.** Fladetempereringssystem (1) ifølge et af de foregående krav, hvor installationspladen (2) er udformet som en isoleringsplade, og varmeledningsfolierne (5, 6) er fremstillet af et aluminiumsmateriale eller et grafitmateriale.
- 15      **10.** Fremgangsmåde til fremstilling af et fladetempereringssystem (1) ifølge et af kravene 1 til 9, omfattende trinnene:  
- tilvejebringelse af en installationsplade (2);  
- anbringelse af mindst en rørføringskanal (4), der er åben ud mod en overside (3) af installationspladen (2); og
- 20      - påføring af to varmeledningsfolier (5,6) på oversiden (3) af installationspladen (2) på en sådan måde, at disse varmeledningsfolier (5,6) overlapper hinanden langs med rørføringskanalen (4) i det mindste en sektion.
- 25      **11.** Monteringsfremgangsmåde til fremstilling af en varmevekslerindretning (2), omfattende trinnene:  
- tilvejebringelse af et fladetempereringssystem (1) ifølge et af kravene 1 til 9;  
- anbringelse af et rør (11) i rørføringskanalen (4) på en sådan måde, at varmeledningsfolierne (5,6) i det mindste delvist er trykket ind i rørføringskanalen (4) og beklæder denne i det mindste delvist.

FIG 1

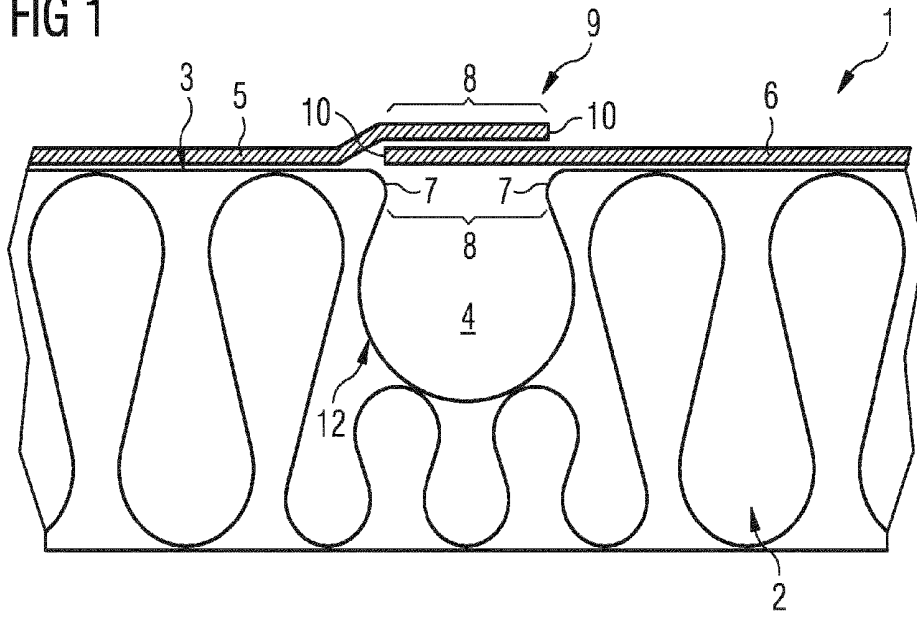

FIG 2

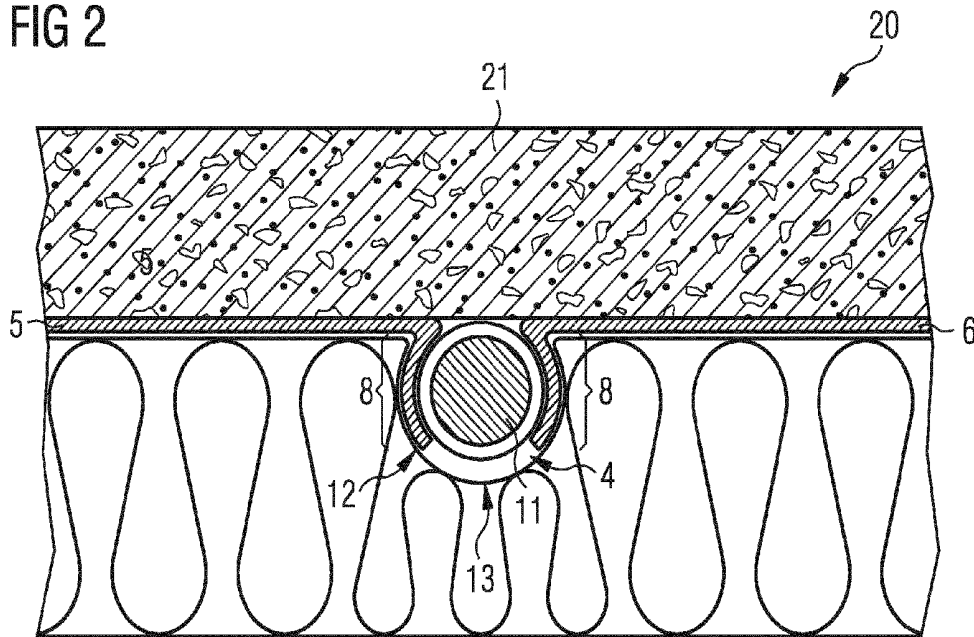

FIG 3

