

J. VANNETTE.
 SEWING MACHINE.
 APPLICATION FILED JULY 21, 1910.

998,053.

Patented July 18, 1911.

2 SHEETS—SHEET 1.

Fig. 1.

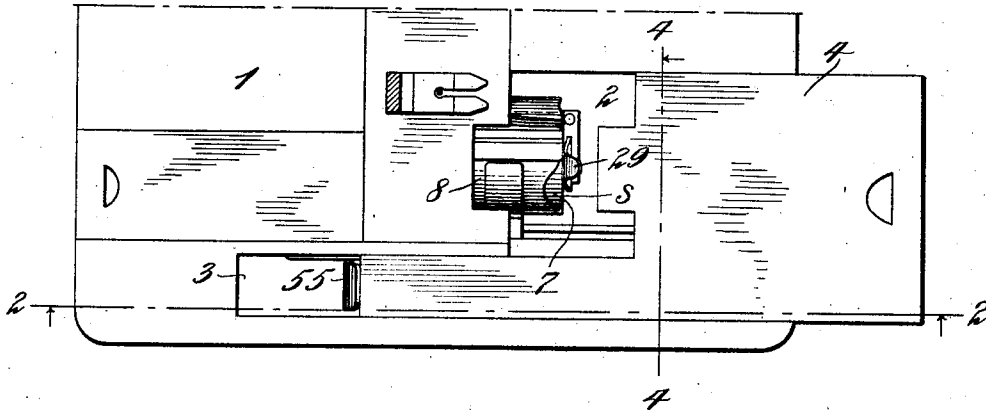

Fig. 2.

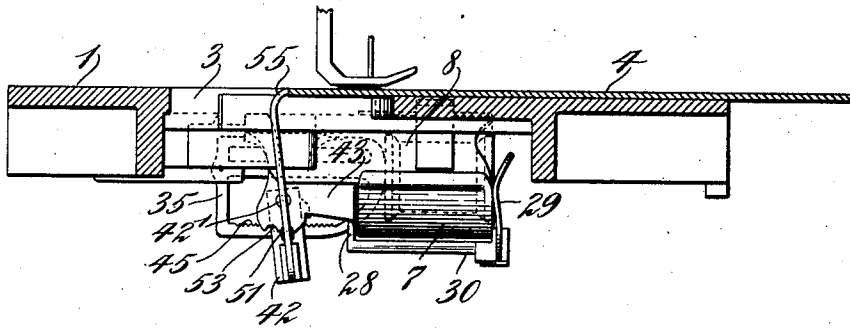
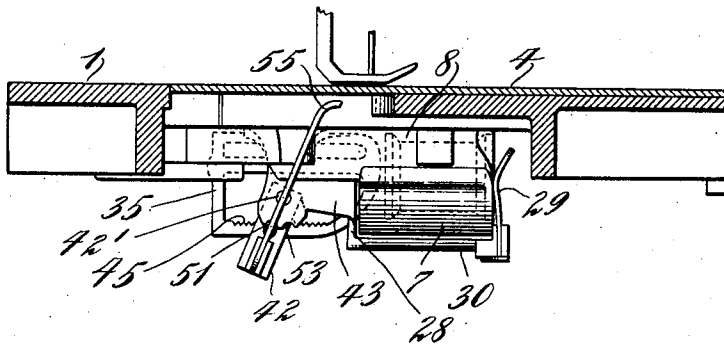

Fig. 3.



Witnesses:
J. P. Cheney
 A. M. Cassidy

Inventor
J. Vannette
 By his Attorney
Chas. H. Rose

J. VANNETTE.
 SEWING MACHINE.
 APPLICATION FILED JULY 21, 1910.

998,053.

Patented July 18, 1911.

2 SHEETS—SHEET 2.

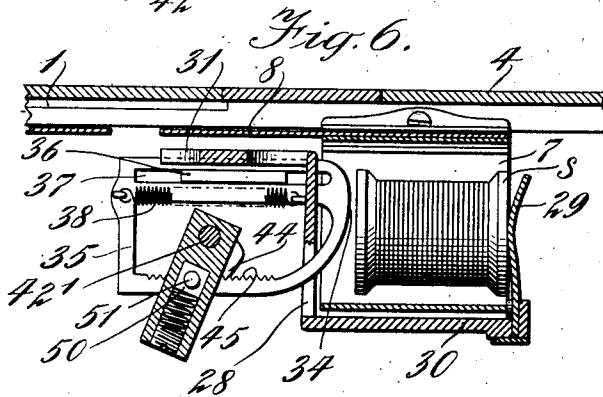
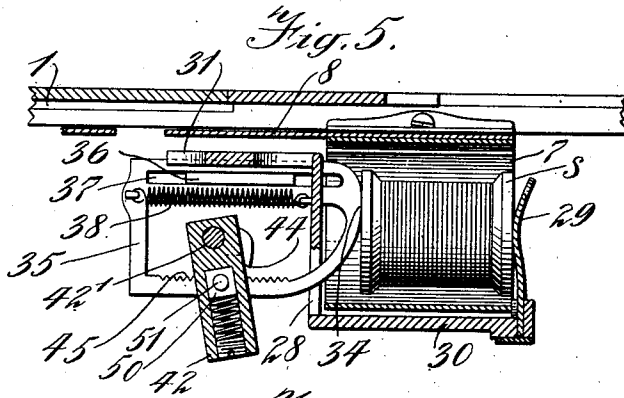
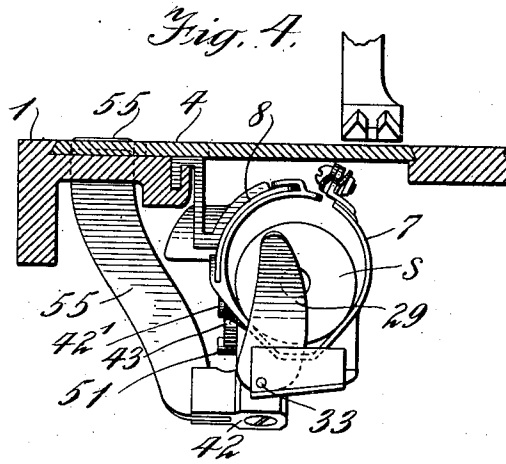

Witnesses:
Sp. G. Johnson
 H. M. Cassidy

Inventor
J. Vannette
 By *his Attorney*
Chas. H. Dancy

UNITED STATES PATENT OFFICE.

JASPER VANNETTE, OF TIFFIN, OHIO.

SEWING-MACHINE.

998,053.

Specification of Letters Patent. Patented July 18, 1911.

Application filed July 21, 1910. Serial No. 572,995.

To all whom it may concern:

Be it known that I, JASPER VANNETTE, citizen of the United States, and resident of Tiffin, in the county of Seneca and State of Ohio, have invented certain new and useful Improvements in Sewing-Machines, of which the following is a specification.

My invention relates to lock-stitch sewing machines of that class in which both the upper and under thread is taken direct from the ordinary commercial spool of sewing thread, and it has more special reference to improvements on the sewing machine of such class made the subject of Letters Patent No. 875,751, granted to me Jan. 7, 1908.

In the machine of my aforesaid patent, a spool-case is provided for containing the spool carrying the under-thread supply, and associated therewith are means for holding spools of different sizes within the case without undue endwise movement therein other than enough to permit of the passage of the needle-thread loop between the spool and its engaging parts. This means comprises a movable end wall for the spool-case which is adjustable relatively to an opposing end wall to vary the spool-receiving space therebetween, and an additional means for automatically spacing the said end walls relatively to different sizes of spools inserted into the spool-case to provide in every instance the same predetermined thread-clearance space between the parts. This means for spacing the end walls of the spool-case includes an operating lever therefor, indicated at 42 in the drawing of my aforesaid patent, which is arranged at the under side of the bed-plate in a position necessitating the operator reaching beneath the bed-plate to effect its manipulation; and to reach the said lever at such point it is necessary, according to the character of the stand or cabinet on which the machine is mounted, to either tilt the machine backward to expose its under side or else reach beneath the platform on which the machine is mounted.

Because of such inconvenient location of the said operating lever in the machine of my prior patent, it has been one of the objects of my present invention to provide an improved operating means for effecting the spacing or adjusting of the end walls of the spool-case which may be operated from the upper side of the sewing machine bed-plate.

To this end my invention consists in providing an improved operating device for said end-wall spacing or adjusting means constructed and arranged to be operated from the upper side of the bed-plate, preferably through an opening in the latter.

In adjusting the spool within its case in the machine of my said prior patent, the spool is first entered into the case and secured therein by a latch device constituting one of the end-walls of the case. Thereafter the adjustment or spacing of the end-walls is effected to provide the necessary thread-clearance space, hereinbefore referred to. It sometimes happens, however, that the operator neglects to perform this spacing operation, with the result that upon the starting of the machine the needle-thread loop will be prevented from being carried about the spool-case and will therefore be caused to break.

To provide means for guarding against neglect to perform such end wall spacing operation has therefore been a further object of my present invention.

To such end, the invention consists in so constructing and arranging the said operating device for the end wall spacing means that it will be movable to a position in the path of movement of the sewing machine slide-plate subsequent to the opening of the latter preparatory to the removal of the spool from its case, and in such position prevent closing of said slide plate until subsequent to the device being operated to adjust the end wall spacing means and provide the necessary thread-clearance space, by which operation the device is moved from its said position in the path of movement of the slide-plate.

Referring now to the accompanying drawings forming part of this specification, in which I have shown only so much of a sewing machine as is necessary to illustrate my invention,—Figure 1 is a top plan of the front end of a sewing machine bed-plate and its supported under-thread mechanism, embodying my invention, with the slide-plate partly closed and engaged by the operating device of the spool space adjusting means. Fig. 2 is an end elevation of the same with the bed and slide plates in section on line 2—2 of Fig. 1. Fig. 3 is a corresponding view with the space adjusting means operated to provide thread-clearance space and the slide-plate closed. Fig. 4 is

an enlarged elevation looking from the right in Fig. 1, with the bed and slide plates in section on line 4—4 of Fig. 1. Figs. 5 and 6 are enlarged sectional detail views of the spool-case and its associated parts, showing the operation of the parts in effecting adjustment of the end walls of the spool-case relatively to an inserted spool, and corresponding to the position of the corresponding parts shown by full and dotted lines in Figs. 2 and 3 respectively.

Similar reference characters designate like parts in the several figures of the drawings.

As hereinbefore stated, the spool-case and its associated parts, to which my present invention is applied, are substantially the same as those disclosed in my prior Patent No. 875,751, and therefore the description of the same will be substantially the same as that of the like parts contained in said patent, to which reference may be had.

The bed-plate of the machine, indicated at 1, is provided with the usual opening 2 through which the under-thread carrying spool may be passed in being entered into or withdrawn from the spool case at the under side of the bed-plate. In addition to said opening 2, the bed-plate is also provided in the present case with a second opening 3, to permit of the operation therethrough of the operating device for the spool space adjusting means to be hereinafter described. Both of said openings 2 and 3 are closed by a suitably formed slide-plate 4 operating in guide-ways in the bed-plate in usual manner.

The spool-case 7 at the under side of the bed-plate is of substantially cylindrical form to loosely contain a commercial spool *s* of sewing thread, and is supported by a sliding connection at its exterior side with a reciprocatory frame 8 which in turn is supported by a sliding connection with the bed-plate.

The spool-case driver comprises heel and toe portions 28 and 29 for engaging respectively with the rear and front ends of the spool-case and being connected by an intermediate portion 30 arranged at the under side of the spool-case. The driver as thus formed is provided with an arm or extension 31 at the upper end of its heel portion 28 for connection with the driver actuating means. The toe portion 29 of the said driver is shown as having a pivotal connection 33 with the lower driver portion 30, whereby it may be moved from its normal position opposite the open front end of the spool-case to permit of either the insertion of a spool into said case or its removal therefrom; the said toe 29 serving, when in its normal operative position opposite the open end of the spool-case, as a latch for removably retaining the spool within said case.

In order to prevent undue movement of a spool within the spool-case, for

reasons fully given in my aforesaid patent, I locate at the inner end of the spool-case an adjustable wall 34 which, together with the driver arm or latch 29 at the front end of the case, form the end walls of the spool-case between which the spool is loosely held. The said adjustable wall 34 is provided by the front end of a plate 35 which is slidably supported by the spool-driver at its rear end to be movable therewith and arranged with its said front end 34 extending centrally into the open rear end of the spool-case through a suitable slot in the driver heel 28; the means for so supporting the plate 35 comprising an arm 36 fixedly held to the rear end of the driver and engaging the plate 35 within an elongated slot 37 therein. A spring 38 connecting at one end with the driver and at its opposite end with the plate 35 operates to yieldingly hold the latter in a normal position with its front end wall 34 sufficiently far advanced into the spool-case as to render the spool-receiving space between it and the opposite end wall 29 small enough to closely receive a spool of minimum size, and permit said wall 34 to yield against the pressure of an inserted spool to adapt the spool-receiving space to any size of spool ranging between a minimum and maximum size.

To insert a spool into the spool-case, the latch 29 constituting the front end wall of the spool-case is swung laterally aside to open the spool-case, after which a spool is inserted into the case and moved against the pressure of the yielding wall 34 until it is sufficiently far inserted to permit closing of the end wall latch 29. When a spool is thus inserted into its case, however, it is yieldingly held with its ends in engagement with the opposite end walls 34, 29, of the spool-case, while it is desirable that sufficient space be provided between the spool and the adjacent end walls of the case to permit of the ready passage of the needle-thread loop therebetween without undue friction on the thread. For this reason I provide a means that is operative subsequent to the entry of a spool into the case for moving the adjustable wall 34 a predetermined distance in a direction to increase the spool-receiving space between it and the opposite end wall whereby the desired thread-passage or thread-clearance space between said walls and the spool will be provided. The said means for so moving the adjustable wall 34 comprises a lever 42 fulcrumed on a pivot stud 42' carried by a bracket extension 43 of the spool-case driver (see Figs. 2 and 3), and having a dog 44 for engagement with a series of teeth 45 located on the lower wall of an elongated opening in the adjustable wall-plate 35. With this combination and arrangement of parts, when the lever 42 is swung forward

at its lower end in a direction toward the spool-case, as shown in Figs. 2 and 5, the dog 44 will be released from engagement with the teeth 45 of the plate 35 and the latter will be free to be moved either forward under the action of the spring 38, or backward under the pressure of an inserted spool. With the wall plate 35 thus released from locking engagement with the lever 42 and in its forwardly projected position under the action of the spring 38, when a spool is inserted into the spool-case it will be engaged at its opposite ends by end walls of the spool-case in the manner shown in Figs. 2 and 5. To now provide the desired thread-clearance space between the spool and the adjacent end walls of the spool-case, the lever 42 is swung backward from its said plate-releasing position and causes its dog 44 to engage the adjacent tooth on the wall plate 35 and move the latter backward a predetermined distance to increase the spool-receiving space between the end walls of the spool-case for the purpose stated and as shown in Figs. 3 and 6. As a means to latch the lever 42 in either of its described wall-plate releasing or locking positions, the lever is provided with a latch-pin 51 adapted to engage the bracket 43 within suitably positioned notches 53, 53, therein, as indicated in Figs. 2 and 3 respectively; the said latch-pin 51 being carried by a spring-pressed block 50 slidably mounted in the lever 42 and operative to snap the latch-pin into either of the notches 53, 53, when brought to a position opposite the same.

When it is desired to remove the spool from its case for any purpose, the front end wall or latch 29 is first swung laterally from its position opposite the front end of the case and the lever 42 is then swung forward to release the wall-plate 35, whereupon the latter will be projected forward into the case under the action of the spring 38 and operate to eject the spool from the case; the said plate 35 thus serving both as an adjustable end wall for the spool-case and also as an automatic spool-ejector.

In accordance with my present invention as hereinbefore indicated, provision is made whereby the desired spool-case end wall spacing or adjusting means may be operated from the upper side of the bed-plate, and this is made in the present case by providing the lever 42 with an operating device or handle 55 which extends at its free or operating end to a position adjacent to the opening 3 in the bed-plate through which it may be conveniently reached and operated from the upper side of the bed-plate as will be obvious upon reference to the drawings.

When a spool is to be removed from its case, the operator opens the slide-plate 4 in order to have access to the spool-case at the

under side of the bed-plate and effect the removal of the spool therefrom in the manner hereinbefore described. In effecting such removal of the spool, the upper end of the operating device 55 is moved to a position in the path of the slide-plate, as shown in Figs. 1 and 2, where it prevents closing of said slide-plate prior to the device being operated to effect an increase of the spool-receiving space and provide thread clearance, which operation of the device moves its upper end below the path of movement of the slide-plate and permits closing of the latter, as shown in Fig. 3. In this way, the proper adjustment of the spool-case wall is made necessary before closing of the slide-plate.

What I claim is:—

1. In a sewing machine, the combination with the bed-plate, of a spool-case located beneath said bed-plate, end walls for said case one of which is adjustable relatively to the other in a direction to vary the spool-receiving space therebetween, means operative subsequent to the entry of a spool into the case for moving said adjustable wall a predetermined distance in a direction to increase the said spool-receiving space between it and the opposite end wall, and an operating device for said means having a handle portion projecting upwardly to a position adjacent to the bed-plate whereby it may be operated from the upper side of the latter.

2. In a sewing machine, the combination with the bed-plate having an opening therein, of a spool-case located beneath said bed-plate, end walls for said case one of which is adjustable relatively to the other in a direction to vary the spool-receiving space therebetween, means operative subsequent to the entry of a spool into the case for moving said adjustable wall a predetermined distance in a direction to increase the said spool-receiving space between it and the opposite end wall, and an operating device for said means located in position adjacent to said opening in the bed-plate to be operated therethrough from the upper side of the bed-plate.

3. In a sewing machine, the combination with the bed-plate having an opening therein and a slide-plate for closing said opening, of a spool-case located beneath said bed-plate, end walls for said case one of which is adjustable relatively to the other in a direction to vary the spool-receiving space therebetween, means operative subsequent to the entry of a spool into the case for moving said adjustable wall a predetermined distance in a direction to increase the said spool-receiving space between it and the opposite end wall, and an operating device for said means movable to and from a position in the path of movement of the slide-plate and being adapted to project into the path

of movement of said slide-plate to prevent closing of the latter prior to the device being operated to effect an increase of said spool-receiving space.

5 4. In a sewing machine, the combination with the bed-plate having a spool opening therein and a slide-plate for closing said opening, of a spool-case located beneath said bed-plate, end walls for said case one of
10 which is adjustable relatively to the other in a direction to vary the spool-receiving space therebetween, and means operative subsequent to the entry of a spool into the case for moving said adjustable wall a pre-
15 determined distance in a direction to increase the said spool-receiving space between it and the opposite end wall, said means embodying an operating lever movable to and from a position in the path of
20 movement of the slide-plate and being arranged to project into the path of movement of said slide-plate to prevent closing of the latter prior to the lever being operated to effect an increase of said spool-re-
25 ceiving space.

5. In a sewing machine, the combination with the bed-plate having a spool opening therein and a slide-plate for closing said opening, of a spool-case located beneath said
30 bed-plate, end walls for said case one of which is adjustable relatively to the other in a direction to vary the spool-receiving space

therebetween, means for adjusting the position of said adjustable wall, and an operating device for said adjusting means movable
35 to and from a position in the path of movement of the slide-plate and being adapted to project into the path of movement of said slide-plate to prevent closing of the latter prior to the device being operated to effect
40 space increasing adjustment of said adjustable wall.

6. In a sewing machine, the combination with the bed-plate having an opening therein and a slide-plate for closing said opening,
45 of a spool-case located beneath said bed-plate, end walls for said case one of which is adjustable relatively to the other in a direction to vary the spool-receiving space there-
50 between, and adjusting means for said adjustable end wall movable to and from a position in the path of movement of the slide-plate and being adapted to project into the path of movement of said slide-plate to
55 prevent closing of the latter prior to the adjusting means being operated to adjust the said spool-receiving space.

Signed at New York, in the county of New York, and State of New York, this 15th day of July, A. D. 1910.

JASPER VANNETTE.

Witnesses:

K. M. CASSIDY,
CHAS. F. DANE.