

Oct. 15, 1935.

R. L. HASCHE

2,017,408

COMPRESSION OF CORROSIVE GASES

Filed Nov. 6, 1930

2 Sheets-Sheet 1

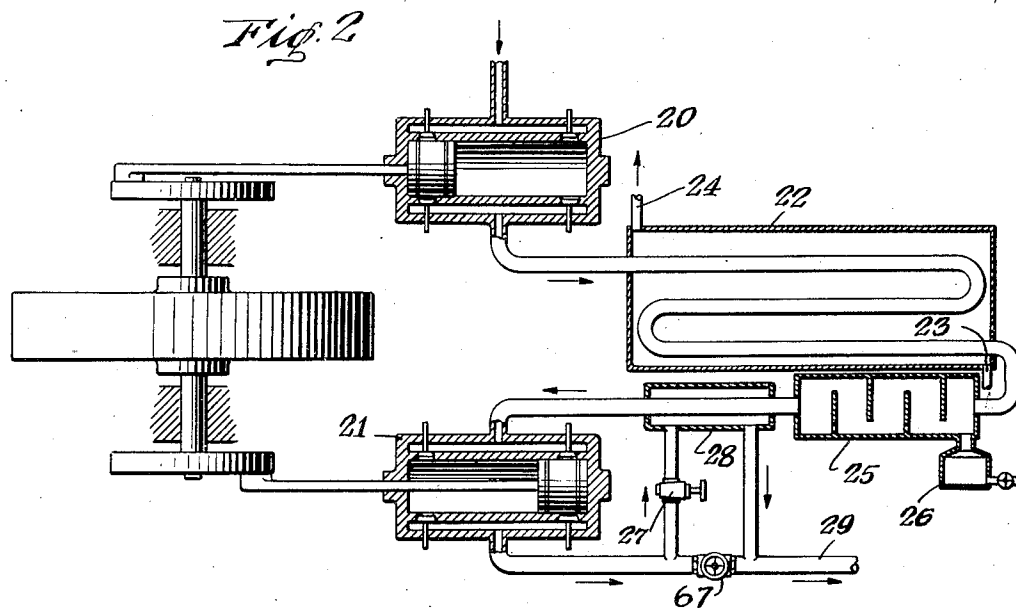
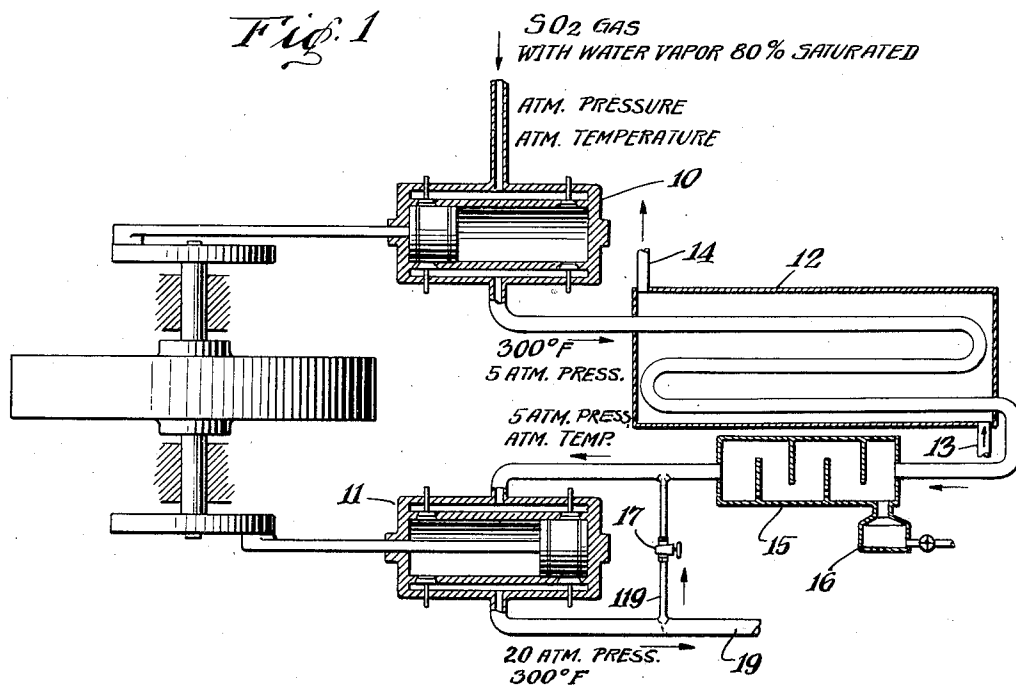

Rudolph L. Hasche
INVENTOR

BY ATTORNEYS Austin & Dix

Oct. 15, 1935.

R. L. HASCHE

2,017,408

COMPRESSION OF CORROSIVE GASES

Filed Nov. 6, 1930

2 Sheets-Sheet 2

Fig. 3

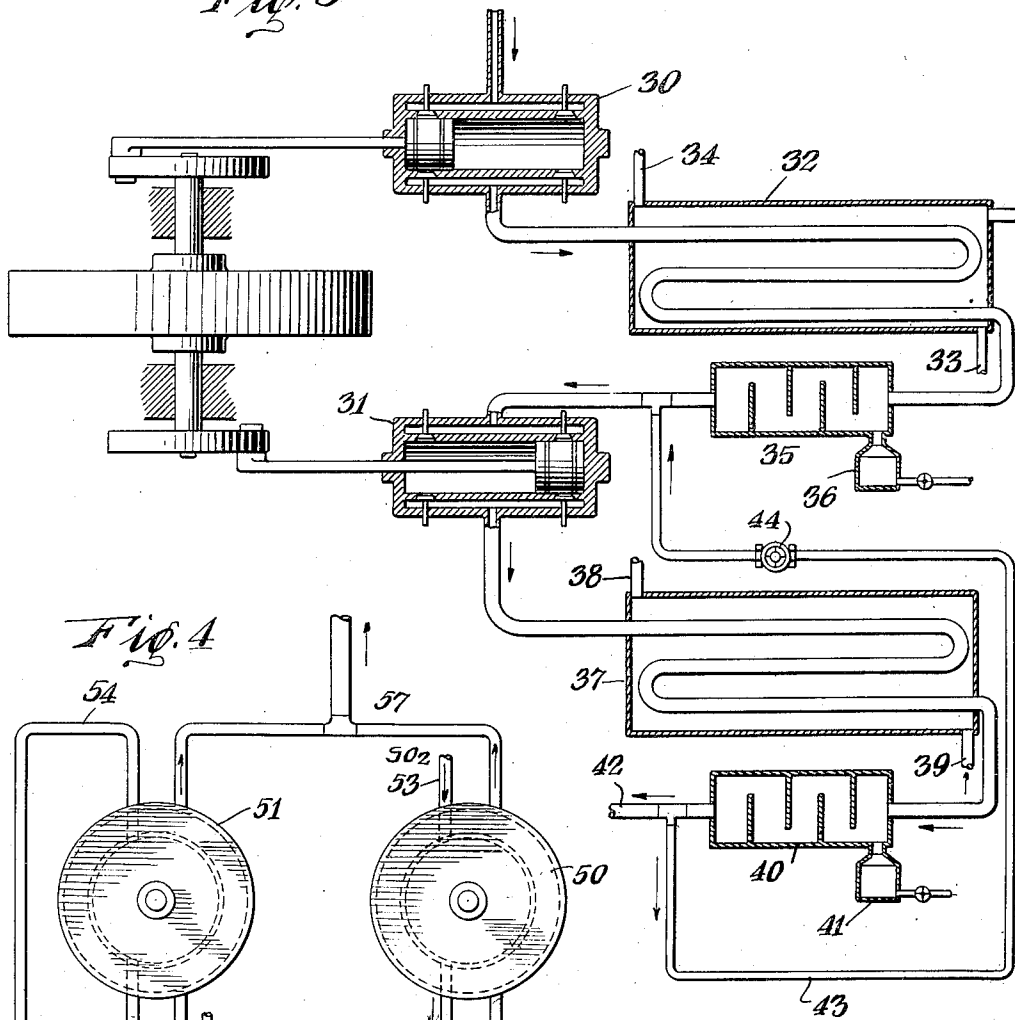
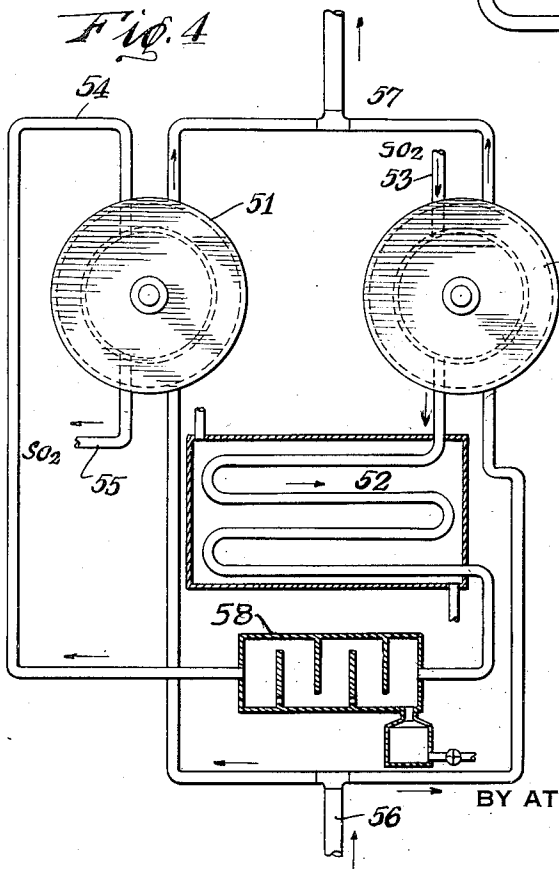

Fig. 4



Rudolph L. Hasche
INVENTOR

BY ATTORNEYS *Custer + Dix*

UNITED STATES PATENT OFFICE

2,017,408

COMPRESSION OF CORROSIVE GASES

Rudolph Leonard Hasche, Red Bank, N. J., assignor to American Smelting and Refining Company, New York, N. Y., a corporation of New Jersey

Application November 6, 1930, Serial No. 493,722

18 Claims. (Cl. 230—208)

The invention relates to systems for compressing gases, and more particularly to a system for compressing corrosive gases.

According to one form which the invention may take, a so-called corrosive gas such as sulphur dioxide-air mixture containing water vapor is compressed in the first stage of a multi-stage compressor, then cooled in an interchanger and thereafter most of the condensed water removed by a suitable separating device. It is not practicable to remove all of the water which is in the liquid phase, so the resultant compressed cooled gas containing some water in the liquid phase is subjected to a treatment which revaporizes the water before the gas is passed into the second stage of the compressor.

According to the invention, the treatment for revaporizing the water above mentioned may be carried out in various ways. For instance, the gas, prior to admission into the second stage compressor, may have added thereto small quantities of heated gas from the discharge side of the second stage compressor. Or, if desired, the gas admitted into the second stage may be externally heated by a suitable heat transferring device, the heat being obtained from the heated gas from the discharge side of the second stage or from an external source.

Another way to revaporize the water is by mixing cold gas with the gas supplied to the second stage, the cold gas having a less moisture content and taken, for instance, from the exhaust of the second stage after the exhaust gas has been cooled and the excess water removed therefrom.

According to the invention, furthermore, the gas may be admitted into the tops of the cylinders of both the first and second stage compressors and the cooling water may be supplied to the bottoms of the cylinders of these compressors. This arrangement is useful in preventing condensation of water in the intake manifolds of the compressor stages.

An important feature of the invention is to prevent the presence of water in the liquid phase in the cylinders of the compressor. It has been found that so-called corrosive gases, such as sulphur dioxide, will not attack the material of the compressors if no water in the liquid phase is present. It is only when water is actually present, which combines with the sulphur dioxide to form sulphurous acid, that trouble occurs. The sulphurous acid attacks the valves, manifolds, pistons and lubricating oil of the compressors, and unless special materials are used to resist this action, great trouble results.

Various other features and advantages of the invention will be apparent from the following particular description and from an inspection of the accompanying drawings, in which

Figs. 1, 2 and 3 are diagrammatic representations of alternative systems for carrying out the invention; and

Fig. 4 is a diagrammatic arrangement illustrating the connection of the gas intake and water intake to the cylinders of the multi-stage compressors.

In the following description and in the claims parts will be identified by specific names for convenience, but they are intended to be as generic in their application to similar parts as the art will permit.

In the drawings accompanying and forming part of this specification, practical commercial embodiments of the invention are shown, but as such illustrations are primarily for purposes of disclosure, it will be understood that the structures may be modified in various respects without departure from the broad spirit and scope of the invention as hereinafter defined and claimed.

Referring now to the drawings, and more particularly to Fig. 1, this figure illustrates an arrangement wherein the water which is present in the liquid phase in the gas intake to the second stage compressor is revaporized by admixing therewith a small amount of heated gas taken from the exhaust of the second stage. In this figure the first stage compressor is denoted by 10 and the second stage compressor is denoted by 11. The gas, which may be sulphur dioxide mixed with air and water vapor, is admitted into the top of the first stage 10. This gas, under some conditions, may be at atmospheric pressure and at atmospheric temperature, and may be 80 per cent saturated with water vapor.

The gas is compressed in the first stage 10 and passed through the heat exchange or cooling device 12 which may be cooled by a circulation of water passing into the device at 13 and out of the device at 14. In the method used for illustration, the gas is compressed to five atmospheres and the temperature raised to 300° F. by the first stage compressor. This gas is cooled to approximately atmospheric temperature by the heat exchange device 12, and the condensed water is separated out by the mechanical separator 15, the water draining into a sump 16, from which it may be removed in any desired manner.

The gas is then fed to the top of the cylinder of the second stage compressor under pressure of five atmospheres and at atmospheric temperature, and is compressed in the case illustrated to twenty atmospheres, the temperature rising to 300° F. From this point, the exhaust gas may be delivered by the pipe 19 to any desired point.

A by-pass pipe 19 which may be quite small and having a valve 17 connects the intake and exhaust of the second stage compressor 11. Thus, the hot gas from the discharge side of the second stage is mixed in small quantities with the in-

coming cold gas having water present in the liquid phase. The heat supplied serves to revaporize the water and hence no water in the liquid phase is present in the compressor to combine with the corrosive gas to form dangerous corrosive acids which attack the material of the compressor.

The amount of gas it is necessary to by-pass through by-pass pipe 119 to accomplish the purpose intended is a small amount of the total gas. It is preferable that the amount of gas by-passed not exceed, say 5% in order to maintain high volumetric efficiency.

Referring now to Fig. 2, this figure illustrates the system in which heat only is supplied to the gas entering the second stage. In this figure the first stage compressor is denoted by 20, and the second stage compressor is denoted by 21. The heat interchanger is denoted by 22 and has the water intake at 23 and water outlet at 24. The mechanical separator is denoted by 25 having its water sump 26.

The exhaust from the second stage compressor 21 is delivered by pipe 29 to any desired point. If we assume the same temperatures, pressures and other values used for illustration in Fig. 1, the gas delivered by the second stage is at 300° F. and at twenty atmospheres pressure. A small portion of this gas is by-passed through a manifold 28 surrounding the intake pipe, the amount being controlled by the valves 27 and 67. This hot gas supplies the necessary heat to revaporize the water in the liquid phase which is present in the gas supplied to the second stage.

Referring now to Fig. 3, this figure illustrates the system when cold gas of less water content is mixed with the gas supplied to the second stage. In this figure the first stage compressor is denoted by 30 and the second stage compressor by 31. The heat exchange device is denoted by 32, the cooling water intake by 33, and the cooling water outlet by 34. The mechanical separator is denoted by 35 and its sump by 36. The exhaust gas from the second stage compressor 31 is supplied to a heat exchanger 37 which cools the gas back to substantially atmospheric temperature. This heat exchanger has water inlet 39 and water outlet 38.

The gas is then passed through mechanical separator 40, having a sump 41, and is delivered by pipe 42 to any desired location. A branch pipe 43 is connected from the discharge side of the separator 40 to the inlet of second stage compressor 31, having a control valve 44. The gas by-passing through pipe 43 is at atmospheric temperature but has had considerable water removed by the separator 40, and thereby is of less water content than the gas supplied to second stage compressor 31. But small quantities of this gas are sufficient to revaporize water which is in the liquid phase in the gas supplied to the second stage compressor 31.

Referring now to Fig. 4, the first stage compressor is denoted by 50 and second stage compressor is denoted by 51. Each compressor is provided with a separate water jacket for the cylinder and heads. Cooling water is supplied to the bottom of the water jackets by pipe 56, the cylinder and heads of each compressor being connected in parallel and the compressors being also in parallel as shown. This water passes out through the top of the water jackets through pipes 57 in parallel.

The corrosive gas is fed to the top of first stage compressor 50 by pipe 53 and is exhausted from the bottom of the compressor into the heat ex-

change device 52. The heat exchange device 52 then delivers the gas to a separator 58, whence the gas is delivered to the top of the second stage compressor 51 by pipe 54. The exhaust from compressor 51 is at the bottom through pipe 55. It will be understood that the water jackets on the cylinders of the stages of the compressors shown in Figs. 1, 2, and 3 may be connected as illustrated in Fig. 4, and likewise the intake and exhaust manifolds for the gas.

By having the gas inlet to each cylinder at the top and the water inlets to each cylinder at the bottom, the danger of water condensation in the compressor cylinders is lessened.

Thus it will be seen by the systems above described that the presence of water in the liquid phase in the gas in the compressor cylinders is prevented by changing the physical state of equilibrium of the gas to increase its capacity to hold water in vapor form. Ordinarily, this may be done in three ways: first, by dropping the pressure; second, by raising the temperature; and third, by adding gas of less relative humidity. The first way is impractical for obvious reasons. The second way is illustrated in Fig. 2, while the third way is illustrated in Figs. 1 and 3.

By the systems above described no corrosive action will take place in the cylinders of the compressors. Since the presence of water in the liquid phase in the compressors is prevented, no corrosive acid, such as sulphurous acid in the case of sulphur dioxide can be formed. The counter current flow of the water in cylinders with respect to the flow of the gas permits the intake manifolds to be operated at temperatures slightly above atmospheric, which assists in preventing moisture condensation at this point.

While certain novel features of the invention have been shown and described and are pointed out in the annexed claims, it will be understood that various omissions, substitutions and changes may be made by those skilled in the art without departing from the spirit of the invention.

What is claimed is:

1. The method of compressing a corrosive gas containing moisture in a multi-stage compressor which comprises compressing the gas in a lower stage, cooling the compressed gas, and removing excess water in its liquid phase therefrom, compressing the resultant gas in the next stage, cooling the gas thus compressed, removing excess water in its liquid phase therefrom and mixing the resultant gas with the gas entering said next stage in such quantity as to cause the resultant gas entering said next stage to hold all its water in the vapor phase.

2. In a system for compressing corrosive gases, a first compressor stage, a second compressor stage, a cooling device receiving gas from said first stage, a water separator receiving gas from said cooling device for separating the water therefrom, said second stage receiving gas from said separator, a path between the outlet of the second stage and the inlet of the second stage between said second stage and separator, whereby the condition of the gas in the outlet of the second stage is used to cause the gas entering the second stage to hold all its water in the vapor phase.

3. In a system for compressing corrosive gases without injuring the compressor, a compressor, means to feed a corrosive gas containing water in the liquid phase to the inlet of said compressor, a by-pass leading from a point directly adjacent the outlet of the compressor to the inlet of the com-

pressor for recycling small but sufficient quantities of compressed gas to bring the state of the input gas above the dew point.

4. In a system for compressing corrosive gases, a first compressor stage, a second compressor stage, a cooling device receiving gas from said first stage, a water separator receiving gas from said cooling device for separating the water therefrom, said second stage receiving gas from said separator, a by-pass between the outlet of the second stage and the inlet of the second stage between said second stage and separator for recycling sufficient compressed gas to bring the state of the gas entering the second stage above the dew point thereof.

5. In a system for compressing corrosive gases without injuring the compressor, a heat exchanger, means to feed a corrosive gas containing water in the liquid phase to said heat exchanger, a compressor receiving gas from said heat exchanger, means for passing output gases from a point directly adjacent the outlet of the compressor to said heat exchanger in sufficient quantities to bring the state of the gas leaving said heat exchanger above the dew point thereof.

6. In a system for compressing corrosive gases, a first compressor stage, a second compressor stage, a cooling device receiving gas from said first stage, a water separator receiving gas from said cooling device for separating the water therefrom, a heat exchanger receiving gas from said separator, said second stage receiving gas from said heat exchanger, and means for passing the outlet gases from said second stage through said heat exchanger to bring the state of the gas entering the second stage above the dew point thereof.

7. In a system for compressing corrosive gases without injuring the compressor, a compressor, means to feed a corrosive gas containing water in the liquid phase to said compressor, a cooling device receiving gas from said compressor, a water separator receiving gas from said cooling device, a by-pass leading from the outlet of the water separator to a point directly adjacent the inlet of the compressor for recycling small but sufficient quantities of gas to change the physical state of equilibrium of the gas entering the compressor to increase its capacity to hold water in the vapor phase.

8. In a system for compressing corrosive gases, a first compressor stage, a second compressor stage, a cooling device receiving gas from said first stage, a water separator receiving gas from said cooling device for separating the water therefrom, said second stage receiving gas from said separator, a second cooling device receiving gas from said second stage, a second water separator receiving gas from said second cooling device, a by-pass from the outlet of said second water separator connected to a point between said first separator and the inlet of the second stage to cause the gas entering the second stage to hold all its water in the vapor phase.

9. In a system for compressing corrosive gases, a first stage including a pump cylinder, a second stage having a pump cylinder, the gas inlets of both said stages being at the top of the pump cylinders, the gas outlets of both said stages being at the bottom of said pump cylinders, a cooling device connected to the outlet of the first stage, a water separator fed by said cooling device, the outlet of said separator being connected to the inlet of the second stage, water jackets around

said pump cylinders, and means for separately feeding cooling water to the bottom of said jackets and withdrawing said cooling water from the tops of said jackets.

10. The method of compressing a corrosive gas containing water in its liquid phase by a multi-stage compressor, which comprises compressing the said gas in a lower stage, cooling the compressed gas, removing excess liquid phase water therefrom, eliminating the entire remaining liquid phase water from the resultant gas, and then further compressing the gas thus treated in the next higher stage.

11. The method of compressing a corrosive gas containing water in the liquid phase, which comprises eliminating all the liquid phase water from the gas, and then subjecting the gas thus treated to the compressing operation.

12. The method of compressing a corrosive gas containing water in the liquid phase, which comprises vaporizing all said water and then subjecting the gas thus treated to the compressing operation free of liquid phase water.

13. The method of compressing a corrosive gas containing water in the liquid phase, which comprises subjecting the gas to the compressing operation and mixing part of the warmer exhaust gas immediately leaving the compressor with the wet gas about to enter the compressor to vaporize all the water in the gas entering the compressor.

14. The method of compressing a corrosive gas containing water in the liquid phase, which comprises applying externally heat to the gas entering the compressor to vaporize all said water and then subjecting the gas thus treated to the compressing operation.

15. The method of compressing a corrosive gas containing water in the liquid phase, which comprises subjecting the gas to the compressing operation and applying externally heat from the exhaust gas leaving the compressor to the gas entering the compressor to vaporize all said water.

16. The method of compressing a corrosive gas containing water in the liquid phase, which comprises mixing with the wet gas about to enter the compressor, gas of sufficiently less water content in sufficient quantity to cause the resultant gas to hold all its water in the vapor phase and then subjecting the said resultant gas to the compressing operation.

17. The method of compressing corrosive gas containing water vapor in a compressor having a water jacket around the cylinder thereof which comprises feeding the gas into one side of the compressor cylinder, removing the cooling water from said jacket at the same side of the compressor cylinder into which the gas is fed, removing the compressed gas from the opposite side of the compressor cylinder and feeding the cooling water into the water jacket at said opposite side of the compressor cylinder.

18. The method of compressing corrosive gas containing water vapor in a multi-stage compressor having water cooled jackets around the cylinders thereof which comprises feeding in the gas at the top of the cylinder of each stage and removing the compressed gas from the bottom of said cylinders, feeding the cooling water separately for each stage at the bottom of the jacket and removing the cooling water from the top of the jacket.

RUDOLPH LEONARD HASCHE.