

①2 **EUROPEAN PATENT APPLICATION**

②1 Application number: 81101479.4

⑤1 Int. Cl.<sup>3</sup>: **B 24 B 19/02, B 24 B 41/06**

②2 Date of filing: 02.03.81

③0 Priority: 05.03.80 GB 8007400

⑦1 Applicant: **TEKHNECON SERVICES LIMITED**, Valley Way Rockingham Road, Market Harborough Leicestershire (GB)

④3 Date of publication of application: 09.09.81  
Bulletin 81/36

⑦2 Inventor: **Lee, Geoffrey Foster, Ashley Nr. Market Harborough, Leicestershire (GB)**  
Inventor: **Maddaford, John, Appletree Cottage Littleworth Lane Belton, Nr. Uppingham Rutland Leicestershire (GB)**

⑥4 Designated Contracting States: **AT DE FR GB IT SE**

⑧8 Date of deferred publication of search report: 17.03.82 Bulletin 82/11

⑦4 Representative: **Lewis, Samuel Hewitt et al, FORRESTER & BOEHMERT Widenmayerstrasse 4/1, D-8000 München 22 (DE)**

⑤4 **An improved method of grinding, grinding machine, and mechanism for clamping a workpiece in position.**

⑤7 The invention is concerned with the machining of longitudinal ball tracks into the inner joint members (84) of universal joints. A workpiece for the joint member (84) is clamped in position by clamping mechanism (28) of a spindle mechanism (22), by which a split collet is opened into interior engagement with the workpiece, pulling the workpiece onto an annular base surface and into engagement with internally curved surface portions provided by resilient fingers, which engage with the exterior surface of the workpiece. In this position, the longitudinal axis of the joint member (84) coincides with the longitudinal axis of the spindle mechanism (22). The spindle mechanism (22) is then moved arcuately about a further axis relative to a rotating grinding wheel (14) so that the grinding wheel (14) effects machining of one of the ball tracks of the member (84). Subsequent to retraction of the grinding wheel (14), the spindle mechanism (22) is rotated about its longitudinal axis to present to the grinding wheel (14) another surface portion of the joint member (84), and another ball track is machined into the workpiece.

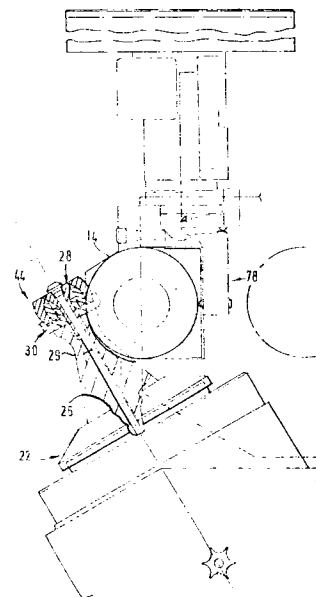



DOCUMENTS CONSIDERED TO BE RELEVANT			CLASSIFICATION OF THE APPLICATION (Int. Cl. <sup>3</sup> )
Category	Citation of document with indication, where appropriate, of relevant passages	Relevant to claim	
	<p><u>US - A - 3 173 336</u> (W. CULL) * column 1 to 5; fig. 1 to 7 *</p> <p>&amp; <u>DE - B - 1 270 928</u> --</p> <p><u>GB - A - 1 480 238</u> (H. DITZEL) * page 3, lines 4 to 57; fig. 1, 2 *</p> <p>--</p> <p>P <u>GB - A - 2 050 567</u> (TOYOTA JIDOSHA KOGYO K.K.) * page 2, lines 49 to 61; fig. 4, 5 *</p> <p>--</p> <p>A <u>GB - A - 780 616</u> (BENDIX AVIATION CORP.) --</p> <p>A <u>US - A - 2 289 683</u> (A.H. RZEPPA et al.) --</p> <p>A <u>GB - A - 1 068 479</u> (BIRFIELD ENGINEERING LTD.) --</p> <p>A <u>FR - A1 - 2 421 024</u> (ETS ROUCHAUD ET LAMASSIAUDE S.A.R.L.) --</p> <p>A <u>DE - A - 1 931 446</u> (NIPPON SEIKO K.K.) &amp; <u>US - A - 3 592 023</u> --</p> <p>A <u>US - A - 3 517 939</u> (E.C. JAEHN) -----</p>	<p>1,3, 4,6</p> <p>1,5</p> <p>1</p>	<p>B 24 B 19/02 B 24 B 41/06</p> <p>TECHNICAL FIELDS SEARCHED (Int. Cl.<sup>3</sup>)</p> <p>B 23 B 31/00 B 23 C 3/28 B 24 B 19/02 B 24 B 41/06 F 16 D 3/22</p> <p>CATEGORY OF CITED DOCUMENTS</p> <p>X: particularly relevant A: technological background O: non-written disclosure P: intermediate document T: theory or principle underlying the invention E: conflicting application D: document cited in the application L: citation for other reasons</p> <p>&amp;: member of the same patent family. corresponding document</p>
<input checked="" type="checkbox"/>	The present search report has been drawn up for all claims		
Place of search	Date of completion of the search	Examiner	
Berlin	08-12-1981	MARTIN	