

Feb. 7, 1961

T. M. JACKSON ET AL

2,971,109

COLD CATHODE TUBES

Filed Sept. 15, 1959

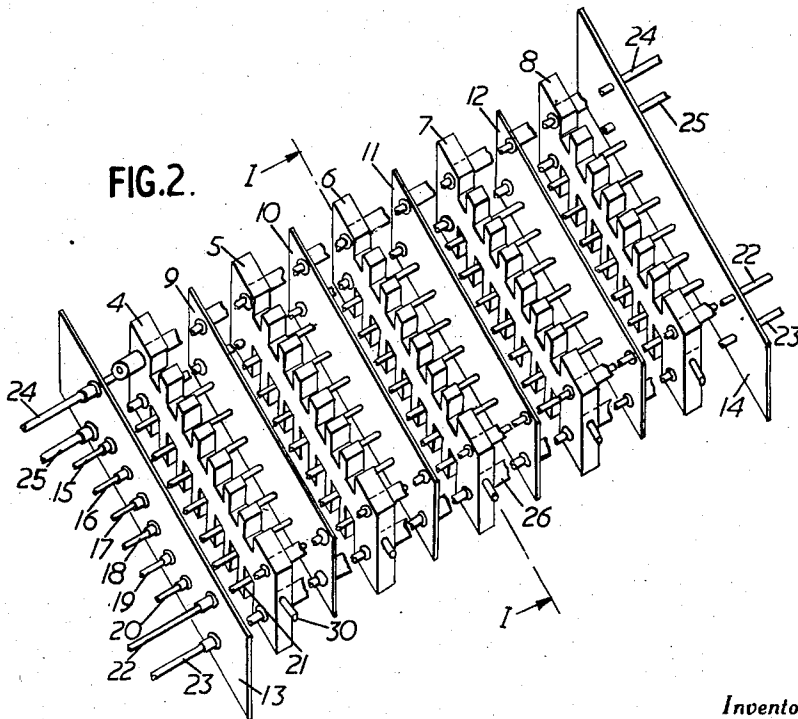
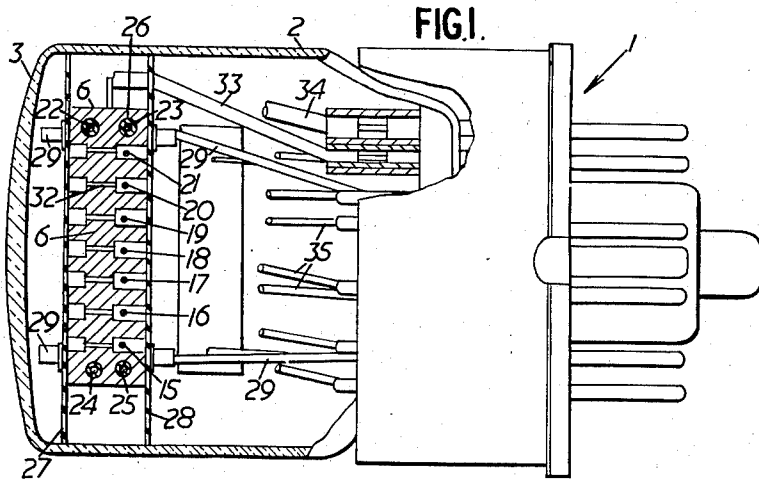

Inventor  
T. M. JACKSON-  
E. A. F. SELL  
By *RF Morris*  
Attorney

1

2,971,109

## COLD CATHODE TUBES

Thomas Meirion Jackson and Eric Andreas Frederik Sell, London, England, assignors to International Standard Electric Corporation, New York, N.Y.

Filed Sept. 15, 1959, Ser. No. 840,102

Claims priority, application Great Britain Oct. 3, 1958

6 Claims. (Cl. 313-188)

This invention relates to cold cathode character display tubes.

One known form of cold cathode display tube has a plurality of cathodes and anodes disposed in a co-ordinate array. The cathodes and anodes are of wires with the anode wires insulated from one another and in one plane and with the cathode wires also insulated from one another and in another plane. A scanning arrangement primes each anode-cathode cross-over sequentially and by simultaneously applying pulses across certain of these primed cross-over sections, these certain sections will glow. The outline formed by the combination of the glowing sections will display information in accordance with the pulses. The outline, however, for some applications may be insufficiently defined, and there may also be a tendency for the glow to spread from one section to another thus further deteriorating the definition.

In another known form of cold cathode display tube there are a plurality of cathodes insulated from one another and each is formed to display a separate character—i.e. letter, figure or symbol—when connected as the cathode element. These cathodes are positioned one behind another and there will thus be a restriction on the number of cathodes which could be contained within one tube envelope. In addition to this consequent restriction on the number of characters, there will also be a tendency for those characters furthest from the viewing face of the envelope to be obscure.

It has been found in a cold cathode tube with two planar cathodes disposed facing each other and cooperating with a common anode, that by reducing the distance between the cathodes and keeping the discharging gap potential at a constant value, a distance is reached at which the glows on both cathodes are about to coalesce. This distance is dependent upon the gas and the pressure within the tube, and when this state is achieved the current density is increased from 100 to 1000 times larger than with a normal glow and the intensity of glow is similarly increased.

This increase in intensity is herein referred to as the "hollow cathode effect," so called because the effect is most readily obtained by glow discharge to the wall surfaces of a hole drilled in a metal cathode electrode. In this latter arrangement the anode is external to the hole and the glow is substantially within the hole. The effect as indicated above, depends upon the size of the hole in relation to the composition and pressure of the gas filling. With a cathode having a hole therethrough of 0.5 mm. diameter, the hollow cathode effect becomes clearly marked in helium at a pressure of 45 mm. Hg. Using the same cathode and neon gas the effect is obtainable over a wider range of pressure.

The present invention utilizes the hollow cathode effect to provide a co-ordinate array display tube in which selected "points" to be displayed are intensely luminous, while yet the glow discharge at any one or more points neither spreads to neighbouring areas, nor primes adjacent "points." To this end rows of cathode electrodes,

2

each in the form of metal bars pierced with a row of holes whose wall surfaces are the actual cathode surfaces of the several discharge gaps, are assembled together with anode rods lying transversely across the cathode bars, each rod being opposite one corresponding hole in each bar. The cathode bars are preferably made of aluminum, anodised except in the holes, and, in the embodiment to be described, have castellations raised on each side, like teeth in a double sided comb, the holes being pierced in the troughs between castellations. Adjacent holes in the same cathode bar are thus effectively isolated from one another by the castellations between them; strips of mica are clamped between the adjacent cathode bars so as to isolate holes adjacent one another in consecutive cathode bars. The anode rods are arranged to lie along the troughs, and the glow from a discharging "point" is viewed from the opposite side, through the opposite end of the hole.

Normally cold cathode tubes require a large voltage difference between the breakdown voltage and the maintaining voltage. However, since no output signal voltage is required from a display tube it is desirable that these voltages should be as close together as possible so that a minimum voltage swing will be required for switching. Taking this requirement into account together with those for the hollow cathode effect, it has been found that by using a neon-argon mixture of neon + 1% by volume of argon, at a pressure of 100 mm. of mercury, the voltage difference is considerably less than when neon, argon, or helium is used individually.

An embodiment of the invention will now be described with reference to the drawings accompanying the provisional specification, in which:

Fig. 1 is a side view, partly in section, in the plane I—I of Fig. 2, of a cold cathode display tube; and

Fig. 2 is an exploded view in perspective of part of the tube of Fig. 1.

The cold cathode tube shown in Fig. 1 comprises a base 1 and a glass envelope 2 with a viewing face 3 and containing neon + 1% (by volume) or argon at a pressure of 100 mm. Hg. A plurality of anode rods and cathode bars are arranged as a co-ordinate array as shown in Fig. 2 and positioned adjacent to the viewing face 3. There are five castellated cathode bars 4 to 8 each in the form of a double sided comb with the teeth on each side being positioned symmetrically opposite one another. In Fig. 1 is shown a cross-section of the electrode structure taken in a plane through the cathode 6 as indicated at I—I in Fig. 2. A hole 32 extends through the cathode from each base between adjacent teeth on one side to the associated bases on the other side. These holes are each 0.5 mm. diameter and 2 mm. in length.

Each cathode bar is made of aluminium and all its surfaces except for the holes are anodised. These small cylindrical holes are formed after anodising. Inter-leaving mica strips 9 to 12 are sandwiched between the cathode bars 4 to 8 and mica end plates 13 and 14 are clamped on the outer surfaces of the bars 4 and 8 by means of eyelets on rods 22 to 25 which pass through respective holes bushed as at 26, in the ends of the cathode bars.

Seven anode rods 15 to 21 in the form of nickel wires pass through holes in the mica strips 9 to 12 and through the slots between the teeth on the sides of the cathode bars remote from the viewing face. Each anode rod is positioned adjacent to one of the holes in each of the cathode bars—i.e. it lies beneath a row of five corresponding holes in the cathode bars. The anode rod is riveted at its ends to the mica plates 13 and 14. In the exploded view shown in Fig. 2 the anode rods, the support wires 22 to 25 and the bushes 26 are shown extended merely for ease of illustration.

3

The assembly shown in Fig. 2 is mounted between an annular mica disc 27 and a mica disc 28 with rods 29 riveted to these discs and supported by the base of the tube in a manner not shown. The disc 27 is annular so that viewing of the cathodes is not prevented.

The five cathode bars and the seven anode rods are each connected to individual pins on the base of the tube by lead-out wires, and since during operation high voltages will exist between these anode and cathode lead-out wires, special precautions must be taken to screen one set from the other. In this embodiment a set of insulated cathode lead-out wires, such as 33, 34, are connected to stubs 30 (Fig. 2) which are firmly located partially within small holes in the cathode bars, and pass through ceramic tubes such as the tube 31, surrounding the inner ends of the corresponding connecting pins in the base 1. Anode lead-out wires are indicated at 35.

When a character or the like is to be displayed at the viewing face of the tube, certain of the holes in the cathode bars are caused to glow in sequence and it is the outline formed by the combination of these glowing parts which forms the display. There will be a glow discharge at any cathode-anode cross-over when the requisite electrical conditions exist at the cross-over. The dimensions of the holes in the cathode bars are selected such that the hollow cathode effect is achieved when a glow occurs.

A standing bias voltage of +50 volts is applied to the anode rods and a standing bias of -50 volts is applied to the cathode bars. The maintaining voltage is 115 volts and the striking voltage is 124 volts. Positive and negative pulses of 13 volts representative of a character are applied to the anode rods and the cathode bars respectively by a scanning arrangement. Any anode-cathode cross-over section across which these pulses are applied simultaneously will glow, and will extinguish at the end of one pulse because insufficient voltage exists to maintain the discharge. A similar train of pulses is reapplied for so long as it is desired to display the character, the repetition rate and pulse duration being such as to obtain persistence of vision.

It is necessary to obtain effective gap isolation since otherwise a glow would tend to spread from one anode-cathode cross-over to the next. The hollow cathode is a preferential discharge area, furthermore the anodised surface of the cathode bars inhibits discharge. The mica strips 9 to 12 and mica plates 13 and 14 effectively prevent the glow from spreading around the side of the cathode and diffusion of ionising products from the glow is prevented from spreading along the length of the cathode bar by the castellations. The size of the castellations depends upon the gas employed. There is thus obtained adequate isolation between independent gaps and each glow has a high intensity and is of small dimensions.

To simplify switching in the scanning arrangement it may be desirable to apply pulses representative of a character to a common third electrode. One method of performing this is to have two anode wires replacing each single anode rod in the arrangement hereinbefore described. There would thus be 7 auxiliary anode wires and 7 main anode wires, the latter being connected together as a common electrode. More than one additional electrode could be employed. Scanning of the cathode bars and auxiliary anodes is continuous so that

4

each cross-over section is primed sequentially. Pulses representative of a character can be applied without any switching to the common anode electrode to light up the display.

While the principles of the invention have been described above in connection with specific embodiments, and particular modifications thereof, it is to be clearly understood that this description is made only by way of example and not as a limitation on the scope of the invention.

What we claim is:

1. A cold cathode glow discharge tube comprising an envelope, a rectangular co-ordinate array of discharge gaps within said envelope each formed between an anode electrode and the surfaces of a cathode electrode, an ionizable gas within said envelope of a composition and pressure sufficient to provide an intensely luminous "hollow cathode" glow discharge at the said gaps, means inhibiting the spread of glow beyond the said surfaces of said cathodes, and means substantially isolating each discharge gap from coupling within the tube to any other discharge gap.

2. A glow discharge tube according to claim 1 wherein said cathode electrodes comprise a plurality of metal electrodes in the form of a bar having its edge slotted at equal intervals, and said anode electrode comprising a plurality of anode rods positioned transverse to the cathode bars within a corresponding slot in each cathode bar.

3. A glow discharge tube according to claim 2 in which each cathode bar is castellated on two opposite sides with each oppositely projecting pair of castellations in line with one another and in which holes pierce the bars symmetrically in the troughs between adjacent castellations.

4. A glow discharge tube according to claim 3 comprising a strip of insulating material, of width substantially equal to the depth of a cathode bar from end to end of opposite castellations and of length exceeding that between the first and last trough on a bar, said strip of material being clamped between each adjacent pair of cathode bars, and in which each anode rod lies in a respective aligned row of corresponding troughs, passing through close fitting holes in the said strips of insulating material.

5. A glow discharge tube according to claim 4 in which the cathode bars, intervening said insulating strips, and the anode rods are mounted together as a unitary sub-assembly between laminae of insulating material, and the sub-assembly is mounted within a hermetically sealed envelope filled with said gas, with the castellated sides of the cathode bars on the opposite side to the anode rods facing a transparent wall of the envelope, and conducting leads connected to the cathode bars and anode rods being disposed behind the sub-assembly.

6. A glow discharge tube according to claim 5 in which the material of the cathode electrode is aluminium anodised outside the hole or holes from which discharge is desired.

#### References Cited in the file of this patent

#### UNITED STATES PATENTS

1,810,692	Wald	June 16, 1931
2,858,480	Shadowitz	Oct. 28, 1958
2,876,385	Landrey	Mar. 3, 1959