



(86) Date de dépôt PCT/PCT Filing Date: 2008/02/20
 (87) Date publication PCT/PCT Publication Date: 2008/08/28
 (85) Entrée phase nationale/National Entry: 2009/07/10
 (86) N° demande PCT/PCT Application No.: US 2008/002285
 (87) N° publication PCT/PCT Publication No.: 2008/103406
 (30) Priorité/Priority: 2007/02/20 (US60/902,267)

(51) Cl.Int./Int.Cl. *A61M 1/00* (2006.01)
 (71) Demandeur/Applicant:
KCI LICENSING INC., US
 (72) Inventeur/Inventor:
LAWHORN, THOMAS P., US
 (74) Agent: BORDEN LADNER GERVAIS LLP

(54) Titre : SYSTEME ET PROCEDE POUR DISTINGUER UNE FUITE D'UN DETACHEMENT DE RECIPIENT DANS UN SYSTEME DE TRAITEMENT A PRESSION REDUITE
 (54) Title: SYSTEM AND METHOD FOR DISTINGUISHING LEAKS FROM A DISENGAGED CANISTER CONDITION IN A REDUCED PRESSURE TREATMENT SYSTEM

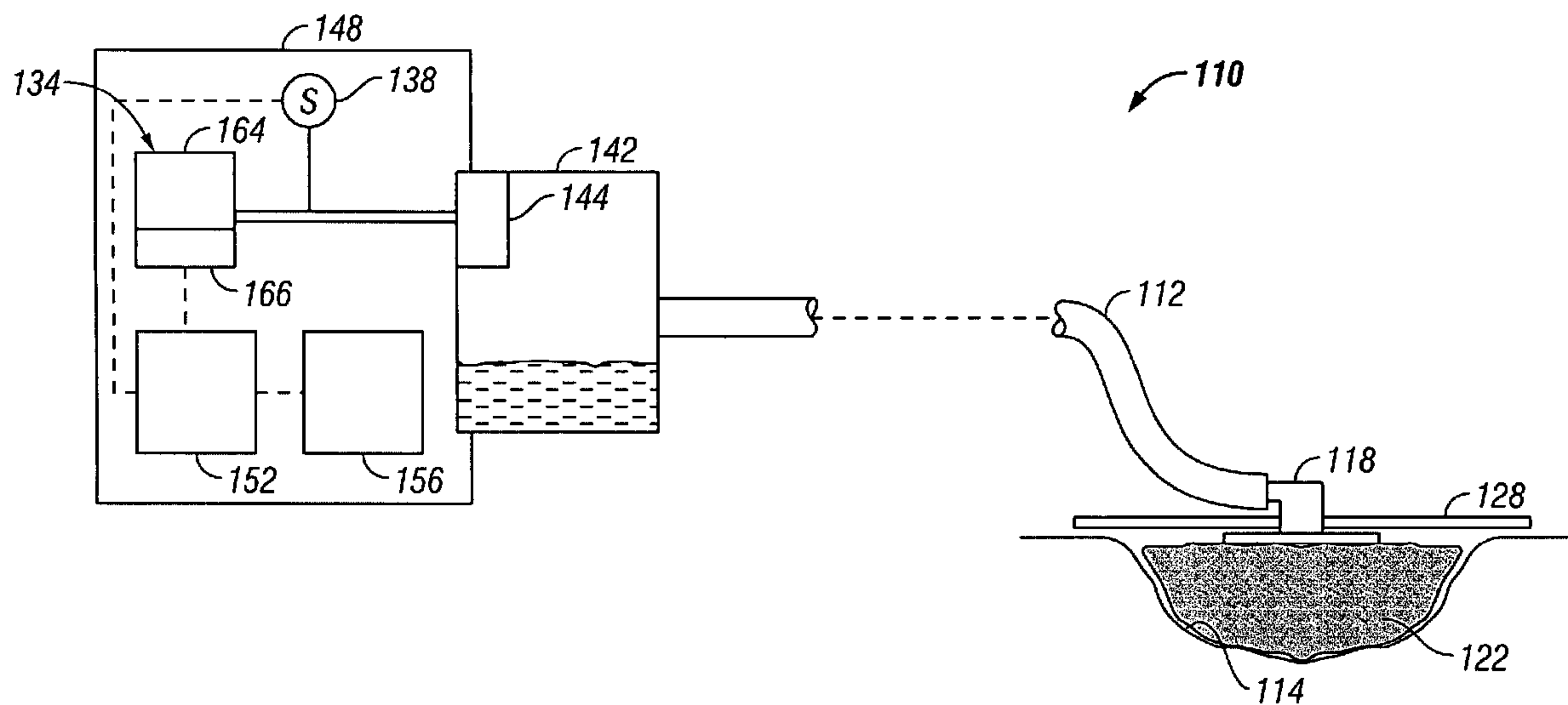

FIG. 1

(57) **Abrégé/Abstract:**

A reduced pressure treatment system includes a processing unit, a reduced pressure source, and a conduit fluidly connected between the reduced pressure source and a tissue site of a patient. The reduced pressure source is configured to operate at a target power level to apply a reduced pressure to the tissue site. A canister is provided to collect fluid drawn from the tissue site. A sensor is provided in communication with the reduced pressure source to determine a source pressure at the reduced pressure source, and an alarm indicator is provided in communication with the processing unit. The processing unit communicates a leak alarm signal or a canister disengaged alarm signal to the alarm indicator when an actual power level of the reduced pressure source exceeds the target power level for a selected period of time.

(12) INTERNATIONAL APPLICATION PUBLISHED UNDER THE PATENT COOPERATION TREATY (PCT)

(19) World Intellectual Property Organization
International Bureau(43) International Publication Date
28 August 2008 (28.08.2008)

PCT

(10) International Publication Number
WO 2008/103406 A1(51) International Patent Classification:
A61M 1/00 (2006.01)(21) International Application Number:
PCT/US2008/002285(22) International Filing Date:
20 February 2008 (20.02.2008)

(25) Filing Language: English

(26) Publication Language: English

(30) Priority Data:
60/902,267 20 February 2007 (20.02.2007) US(71) Applicant (for all designated States except US): **KCI LICENSING INC.** [US/US]; Legal Department-intellectual Property, P.o. Box 659508, San Antonio, TX 78265-9508 (US).

(72) Inventor; and

(75) Inventor/Applicant (for US only): **LAWHORN, Thomas, P.** [US/US]; 11603 Dense Star, San Antonio, TX 78245 (US).(74) Agents: **WELCH, Gerald, T.** et al.; Kinetic Concepts, Inc., P.O. Box 659508, San Antonio, TX 78265-9508 (US).

(81) Designated States (unless otherwise indicated, for every kind of national protection available): AE, AG, AL, AM, AO, AT, AU, AZ, BA, BB, BG, BH, BR, BW, BY, BZ, CA, CH, CN, CO, CR, CU, CZ, DE, DK, DM, DO, DZ, EC, EE, EG, ES, FI, GB, GD, GE, GH, GM, GT, HN, HR, HU, ID, IL, IN, IS, JP, KE, KG, KM, KN, KP, KR, KZ, LA, LC, LK, LR, LS, LT, LU, LY, MA, MD, ME, MG, MK, MN, MW, MX, MY, MZ, NA, NG, NI, NO, NZ, OM, PG, PH, PL, PT, RO, RS, RU, SC, SD, SE, SG, SK, SL, SM, SV, SY, TJ, TM, TN, TR, TT, TZ, UA, UG, US, UZ, VC, VN, ZA, ZM, ZW.

(84) Designated States (unless otherwise indicated, for every kind of regional protection available): ARIPO (BW, GH, GM, KE, LS, MW, MZ, NA, SD, SL, SZ, TZ, UG, ZM, ZW), Eurasian (AM, AZ, BY, KG, KZ, MD, RU, TJ, TM), European (AT, BE, BG, CH, CY, CZ, DE, DK, EE, ES, FI, FR, GB, GR, HR, HU, IE, IS, IT, LT, LU, LV, MC, MT, NL, NO, PL, PT, RO, SE, SI, SK, TR), OAPI (BF, BJ, CF, CG, CI, CM, GA, GN, GQ, GW, ML, MR, NE, SN, TD, TG).

Declaration under Rule 4.17:

— as to applicant's entitlement to apply for and be granted a patent (Rule 4.17(ii))

Published:

— with international search report

(54) Title: SYSTEM AND METHOD FOR DISTINGUISHING LEAKS FROM A DISENGAGED CANISTER CONDITION IN A REDUED PRESSURE TREATMENT SYSTEM

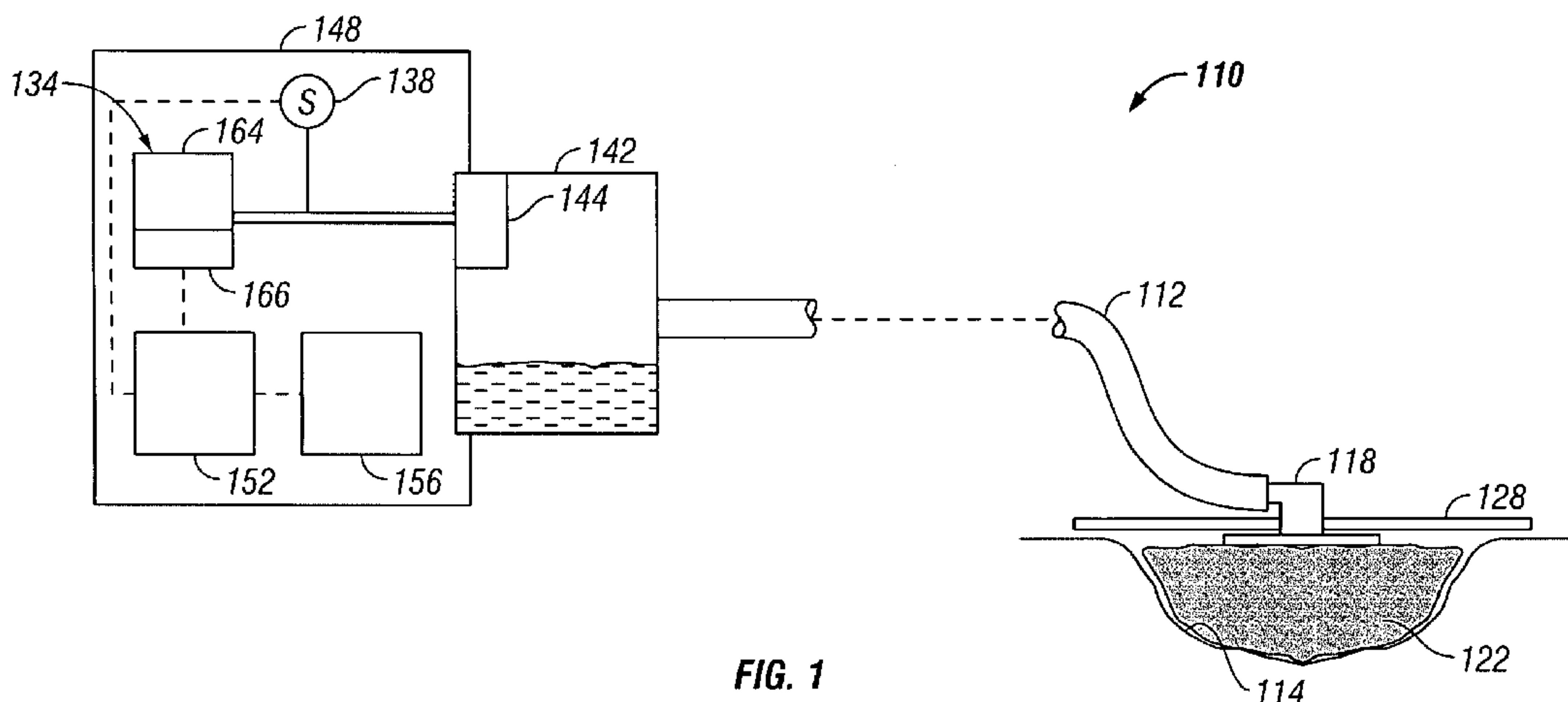

FIG. 1

(57) Abstract: A reduced pressure treatment system includes a processing unit, a reduced pressure source, and a conduit fluidly connected between the reduced pressure source and a tissue site of a patient. The reduced pressure source is configured to operate at a target power level to apply a reduced pressure to the tissue site. A canister is provided to collect fluid drawn from the tissue site. A sensor is provided in communication with the reduced pressure source to determine a source pressure at the reduced pressure source, and an alarm indicator is provided in communication with the processing unit. The processing unit communicates a leak alarm signal or a canister disengaged alarm signal to the alarm indicator when an actual power level of the reduced pressure source exceeds the target power level for a selected period of time.

WO 2008/103406 A1

SYSTEM AND METHOD FOR DISTINGUISHING LEAKS FROM A DISENGAGED CANISTER CONDITION IN A REDUCED PRESSURE TREATMENT SYSTEM

BACKGROUND

5

1. Field of the Invention

The present invention relates generally to tissue treatment systems and in particular to a reduced pressure treatment system having a system for distinguishing between a leak
10 condition and a disengaged canister condition.

2. Description of Related Art

Clinical studies and practice have shown that providing a reduced pressure in proximity to a tissue site augments and accelerates the growth of new tissue at the tissue site.
15 The applications of this phenomenon are numerous, but application of reduced pressure has been particularly successful in treating wounds. This treatment (frequently referred to in the medical community as “negative pressure wound therapy,” “reduced pressure therapy,” or “vacuum therapy”) provides a number of benefits, including faster healing and increased formulation of granulation tissue. Typically, reduced pressure is applied to tissue through a
20 porous pad or other manifold device. The porous pad contains cells or pores that are capable of distributing reduced pressure to the tissue and channeling fluids that are drawn from the tissue. The porous pad often is incorporated into a dressing having other components that facilitate treatment.

One problem with current reduced pressure systems is the interruption of reduced
25 pressure to the tissue site when a leak develops in the system or a component of the system, such as a fluid collection canister, becomes disengaged. Previous reduced pressure systems used a flow sensor to determine the amount of air flow moving through the reduced pressure system. Upon detecting a “high” flow rate, an alarm condition indicating “Canister Not Engaged” was typically activated. If a slightly lower flow rate was detected, it was assumed
30 that a leak had developed, and an alarm condition indicating such was activated. Using a flow sensor to detect these conditions has certain drawbacks. The addition of flow sensors to the reduced pressure system requires additional hardware and the associated software required to receive and process data from the flow sensors. The flow sensors also may exhibit decreased

accuracy due to certain environmental conditions. For example, when the flow rate sensor determines flow by measuring a pressure drop across an orifice, temperature conditions may dramatically affect the hardware sensing the pressure drop, thereby presenting errors in the final flow rate determination.

5

SUMMARY

The problems presented by existing detection systems are solved by the systems and methods of the illustrative embodiments described herein. In one embodiment, a reduced pressure treatment system is provided and includes a processing unit, a reduced pressure source, and a conduit fluidly connected between the reduced pressure source and a tissue site of a patient. The reduced pressure source is configured to operate at a target power level to apply a reduced pressure to the tissue site. The reduced pressure treatment system further includes a canister in fluid communication with the conduit and the reduced pressure source for collecting fluid drawn from the tissue site. A drape is configured for positioning over the tissue site to maintain the reduced pressure at the tissue site. A sensor is provided in communication with the reduced pressure source to determine a source pressure at the reduced pressure source, and an alarm indicator is provided in communication with the processing unit. The processing unit is configured to communicate at least one of a leak alarm signal and a canister disengaged alarm signal to the alarm indicator when an actual power level of the reduced pressure source exceeds the target power level for a selected period of time. The alarm indicator is configured to generate an alarm in response to receiving the at least one of the leak alarm signal and the canister disengaged alarm signal.

In another embodiment, a method of distinguishing leak detection and canister disengagement in a reduced pressure treatment system includes monitoring an actual power level and a source pressure of a reduced pressure pump. The actual power level is compared to a target power level, and the source pressure is compared to a first alarm pressure and a second alarm pressure. A leak alarm is indicated when the actual power level is greater than the target power level and the source pressure is greater than the first alarm pressure. A canister disengaged alarm is indicated when the actual power level is greater than the target power level and the source pressure is less than the second alarm pressure.

In still another embodiment, a reduced pressure treatment system includes means for monitoring an actual power level of a reduced pressure pump and means for monitoring a source pressure of the reduced pressure pump. Means for comparing the actual power level to

a target power level and means for comparing the source pressure to a first alarm pressure and a second alarm pressure are also provided. The system may further include means for indicating a leak alarm when the actual power level is greater than the target power level and the source pressure is greater than the first alarm pressure. Finally, the system may further
5 include means for indicating a canister disengaged alarm when the actual power level is greater than the target power level and the source pressure is less than the second alarm pressure.

Other objects, features, and advantages of the illustrative embodiments will become apparent with reference to the drawings and detailed description that follow.

10

BRIEF DESCRIPTION OF THE DRAWINGS

FIG. 1. illustrates a reduced pressure treatment system configured to indicate leak conditions and canister disengaged conditions according to an embodiment of the invention;
15 and

FIG. 2. depicts a method of distinguishing a leak condition from a canister disengagement condition according to an embodiment of the invention.

DETAILED DESCRIPTION OF ILLUSTRATIVE EMBODIMENTS

20

In the following detailed description of the illustrative embodiments, reference is made to the accompanying drawings that form a part hereof. These embodiments are described in sufficient detail to enable those skilled in the art to practice the invention, and it is understood that other embodiments may be utilized and that logical structural, mechanical, electrical, and
25 chemical changes may be made without departing from the spirit or scope of the invention. To avoid detail not necessary to enable those skilled in the art to practice the embodiments described herein, the description may omit certain information known to those skilled in the art. The following detailed description is, therefore, not to be taken in a limiting sense, and the scope of the invention is defined only by the appended claims.

30 The term “reduced pressure” as used herein generally refers to a pressure less than the ambient pressure at a tissue site that is being subjected to treatment. In most cases, this reduced pressure will be less than the atmospheric pressure at which the patient is located. Alternatively, the reduced pressure may be less than a hydrostatic pressure of tissue at the

tissue site. Although the terms “vacuum” and “negative pressure” may be used to describe the pressure applied to the tissue site, the actual pressure applied to the tissue site may be significantly less than the pressure normally associated with a complete vacuum. Reduced pressure may initially generate fluid flow in the tube in the area of the tissue site. As the hydrostatic pressure around the tissue site approaches the desired reduced pressure, the flow may subside, and the reduced pressure is then maintained. Unless otherwise indicated, values of pressure stated herein are gauge pressures. Similarly, references to increases in reduced pressure typically refer to a decrease in absolute pressure, while decreases in reduced pressure typically refer to an increase in absolute pressure.

The term “tissue site” as used herein refers to a wound or defect located on or within any tissue, including but not limited to, bone tissue, adipose tissue, muscle tissue, neural tissue, dermal tissue, vascular tissue, connective tissue, cartilage, tendons, or ligaments. The term “tissue site” may further refer to areas of any tissue that are not necessarily wounded or defective, but are instead areas in which it is desired to add or promote the growth of additional tissue. For example, reduced pressure tissue treatment may be used in certain tissue areas to grow additional tissue that may be harvested and transplanted to another tissue location.

Referring to FIG. 1, a reduced pressure treatment system 110 according to an embodiment of the invention includes a conduit 112 in fluid communication with a tissue site 114 of a patient. The conduit 112 may fluidly communicate with the tissue site 114 through a tubing adapter 118 and a distribution manifold 122. The distribution manifold 122 may be any material, either bioabsorbable or non-bioabsorbable, that is capable of manifolding a reduced pressure to the tissue site 114. In one embodiment, the distribution manifold 122 may be an open-cell, reticulated polyurethane foam. A drape 128 may be placed over the distribution manifold 122 and sealed around a perimeter of the tissue site 114 to maintain reduced pressure at the tissue site 114.

The conduit 112 is fluidly connected to a reduced pressure source 134. A sensor 138 is disposed at or near the reduced pressure source 134 to determine a source pressure generated by the reduced pressure source 134. In one embodiment, the sensor 138 may be a pressure transducer. A canister 142 is fluidly connected between the reduced pressure source 134 and the tissue site 114 to collect exudate and other fluids drawn from the tissue site 114. The canister 142 may include a hydrophobic filter 144 positioned near an outlet of the canister 142 to prevent fluid from exiting the canister and contaminating the reduced pressure source 134.

In one implementation, the canister 142 may be detachably cooperative with a treatment unit 148 that includes the reduced pressure source 134.

The reduced pressure system 110 may further include a processing unit 152 that communicates with at least one of the reduced pressure source 134, the sensor 138, and an alarm indicator 156. The processing unit 152 may include one or more processors, logic, analog components, or any other electronics that enable signals including information, such as source pressure at a reduced pressure source, to be received. The processing unit 152 may process the information provided by the signals. For example, a source pressure signal may be received by the processing unit 152 and a leak alarm and/or canister disengaged alarm may be driven by the processing unit 152.

In one implementation, the reduced pressure source 134 may be a reduced pressure or vacuum pump 164 driven by a motor 166. The processing unit 152 may be configured to receive signals from the motor 166 or components associated with the motor 166 to determine an actual power level that is being required to drive the vacuum pump 164. The processing unit 152 compares the actual power level to a target power level at which the reduced pressure source 134 is initially calibrated to run. When the actual power level exceeds the target power level for a selected period of time, either a leak condition or a canister disengagement condition exists within the reduced pressure system 110. In either of these conditions, the tissue site 114 experiences at least a partial interruption in the supply of reduced pressure. For example, if a leak occurs between the drape 128 and the perimeter of the tissue site 114, it becomes very difficult to maintain a reduced pressure at the tissue site 114. Similarly, if the canister 142 becomes disengaged from the treatment unit 148, the supply of reduced pressure is interrupted. In either of these conditions, additional power is required by the motor 166 and the pump 164 to attempt to maintain a particular level of reduced pressure at the tissue site 114.

To distinguish between a leak condition and a canister disengaged condition, the processing unit 152 monitors the source pressure determined by the sensor 138. When the canister 142 is disengaged, the source pressure is substantially lower than when the canister is engaged because the vacuum pump 164 is not required to maintain the negative pressure through the hydrophobic filter 144 of the canister 142. Thus, to determine a canister disengaged condition, the processing unit 152 compares the source pressure to a first alarm pressure. If the source pressure is below the first alarm pressure, the processing unit communicates a canister disengaged alarm signal to the alarm indicator 156. When the source

pressure remains high, thus indicating that the canister 142 is engaged, then the condition is by default a leak condition. In one configuration, the source pressure may be compared by the processing unit 152 to a second alarm pressure, and when the source pressure exceeds the second alarm pressure, a leak condition is declared. When a leak condition is determined, the processing unit communicates a leak alarm signal to the alarm indicator. In one embodiment, the first and second alarm pressures are equal.

The alarm indicator 156 is capable of generating distinctive alarms in response to receiving leak alarm and canister disengaged alarm signals from the processing unit 152. The alarm indicator may be an audible indicator such as a speaker or a visual indicator such as LEDs or other lights, or alternatively an LCD or other display.

Referring to FIG. 2, an exemplary method 210 for distinguishing between a leak condition and a canister disengagement condition in a reduced pressure treatment system is provided. The method includes at step 214 monitoring an actual power level and, at step 216, monitoring a source pressure of a reduced pressure pump. At step 218, the actual power level is compared to a target power level, and at step 222, the source pressure is compared to a first alarm pressure and a second alarm pressure. At step 226, a leak alarm is indicated when the actual power level is greater than the target power level and the source pressure is greater than the first alarm pressure. A canister disengaged alarm is indicated at step 230 when the actual power level is greater than the target power level and the source pressure is less than the second alarm pressure.

It should be apparent from the foregoing that an invention having significant advantages has been provided. While the invention is shown in only a few of its forms, it is not just limited but is susceptible to various changes and modifications without departing from the spirit thereof.

CLAIMS

We claim:

1. A reduced pressure treatment system comprising:

- 5 a processing unit;
a reduced pressure source;
a conduit fluidly connected between the reduced pressure source and a tissue site of
a patient, the reduced pressure source configured to operate at a target power
level to apply a reduced pressure to the tissue site;
10 a canister in fluid communication with the conduit and the reduced pressure source
for collecting fluid drawn from the tissue site;
a drape configured for positioning over the tissue site to maintain the reduced
pressure at the tissue site;
a sensor in communication with the reduced pressure source to determine a source
15 pressure at the reduced pressure source; and
an alarm indicator in communication with the processing unit, the processing unit
configured to communicate at least one of a leak alarm signal and a canister
disengaged alarm signal to the alarm indicator when an actual power level of
the reduced pressure source exceeds the target power level for a selected
20 period of time, the alarm indicator configured to generate an alarm in
response to receiving the at least one of the leak alarm signal and the
canister disengaged alarm signal.

2. The system according to claim 1, wherein:

- 25 the processing unit is configured to communicate the leak alarm signal when the
source pressure determined by the sensor is greater than a first alarm
pressure; and
the processing unit is configured to communicate the canister disengaged alarm
signal when the source pressure determined by the sensor is less than a
second alarm pressure.

3. The system according to claim 2, wherein the first alarm pressure is equal to the second alarm pressure.
4. The system according to claim 1, wherein the alarm indicator generates a leak alarm in response to receiving the leak alarm signal.
- 5 5. The system according to claim 1, wherein the alarm indicator generates a canister disengaged alarm in response to receiving the canister disengaged alarm signal.
6. The system according to claim 1, wherein the alarm indicator is a speaker and the alarm is a sound produced by the speaker.
7. The system according to claim 1, wherein the alarm indicator is a visual alarm indicator.
- 10 8. The system according to claim 1, wherein the reduced pressure source is a reduced pressure pump.
9. The system according to claim 1, wherein the sensor is a pressure sensor.
10. The system according to claim 1, wherein:
 - the processing unit is configured to communicate the leak alarm signal when the
15 source pressure determined by the sensor is greater than a first alarm pressure;
 - the processing unit is configured to communicate the canister disengaged alarm signal when the source pressure determined by the sensor is less than the first alarm pressure;
 - 20 the alarm indicator generates a leak alarm in response to receiving the leak alarm signal; and
 - the alarm indicator generates a canister disengaged alarm in response to receiving the canister disengaged alarm signal.
11. A method of distinguishing a leak condition from a canister disengagement condition in a
25 reduced pressure treatment system, the method comprising:
 - monitoring an actual power level of a reduced pressure pump;
 - monitoring a source pressure of the reduced pressure pump;
 - comparing the actual power level to a target power level;
 - comparing the source pressure to a first alarm pressure and a second alarm pressure.

indicating a leak alarm when the actual power level is greater than the target power level and the source pressure is greater than the first alarm pressure; and indicating a canister disengaged alarm when the actual power level is greater than the target power level and the source pressure is less than the second alarm pressure.

5

12. The method according to claim 11, wherein the first and second alarm pressures are equal.

13. The method according to claim 11, wherein the indicating steps further comprises audibly indicating.

10

14. The method according to claim 11, wherein the indicating steps further comprises visually indicating.

15. The method according to claim 11, wherein monitoring the source pressure further comprises sensing the source pressure with a pressure sensor.

16. The method according to claim 11, further comprising:

15

delaying indication of the alarms until the actual power level has exceeded the target power level for a selected period of time.

17. A reduced pressure treatment system comprising:

20

means for monitoring an actual power level of a reduced pressure pump;

means for monitoring a source pressure of the reduced pressure pump;

means for comparing the actual power level to a target power level;

means for comparing the source pressure to a first alarm pressure and a second alarm pressure;

means for indicating a leak alarm when the actual power level is greater than the target power level and the source pressure is greater than the first alarm pressure; and

25

means for indicating a canister disengaged alarm when the actual power level is greater than the target power level and the source pressure is less than the second alarm pressure.

18. The system according to claim 17, wherein the first and second alarm pressures are equal.

19. The system according to claim 17, wherein the means for indicating further comprise means for audibly indicating.
20. The system according to claim 17, wherein the means for indicating further comprise means for visually indicating.

1/2

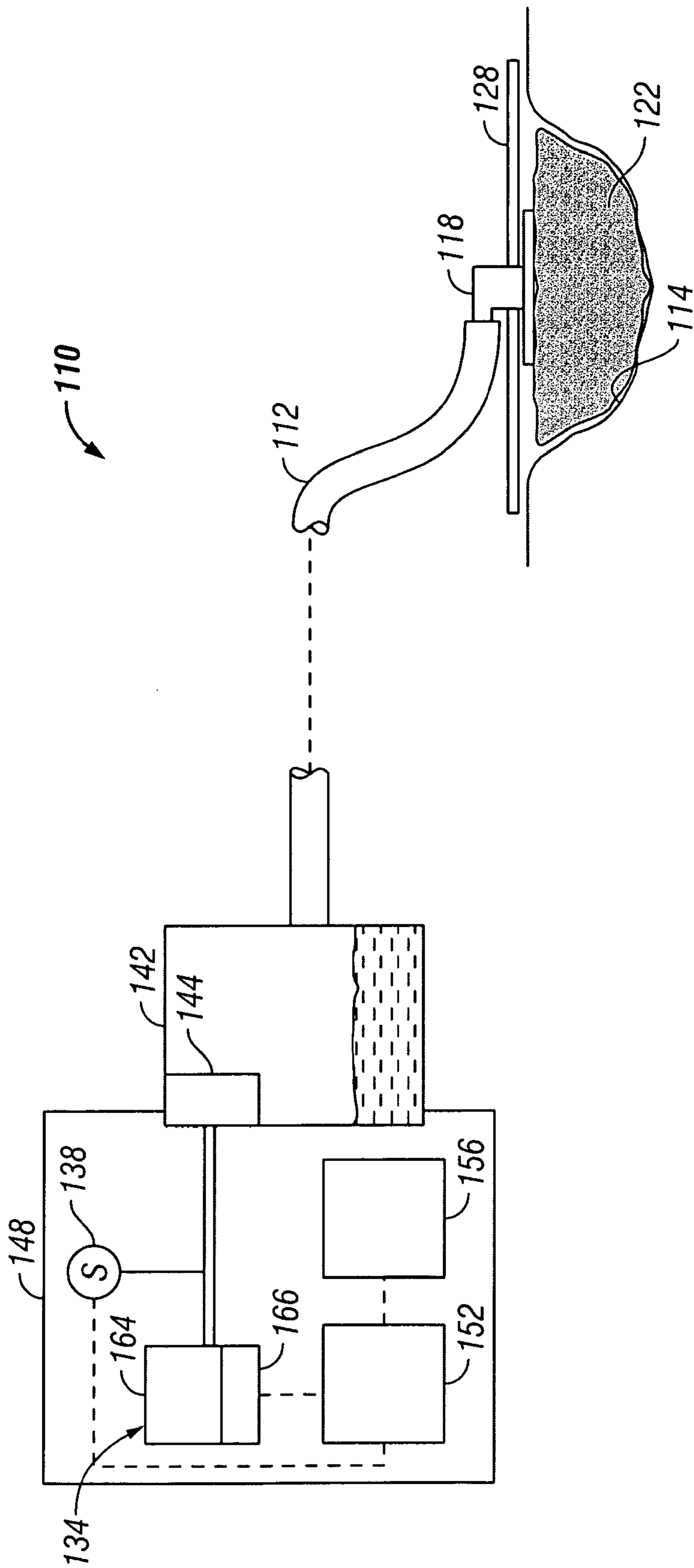

FIG. 1

2/2

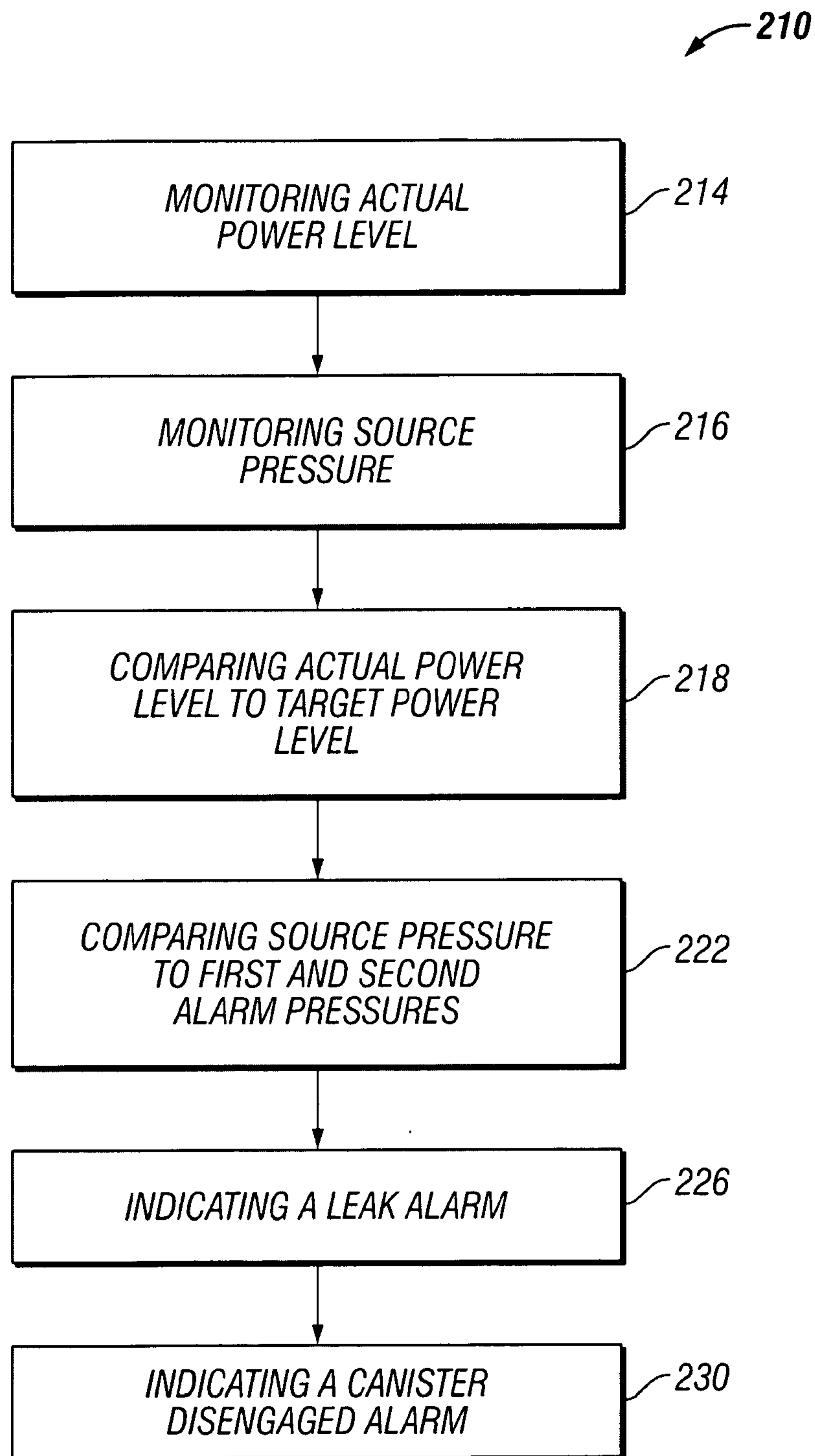

FIG. 2

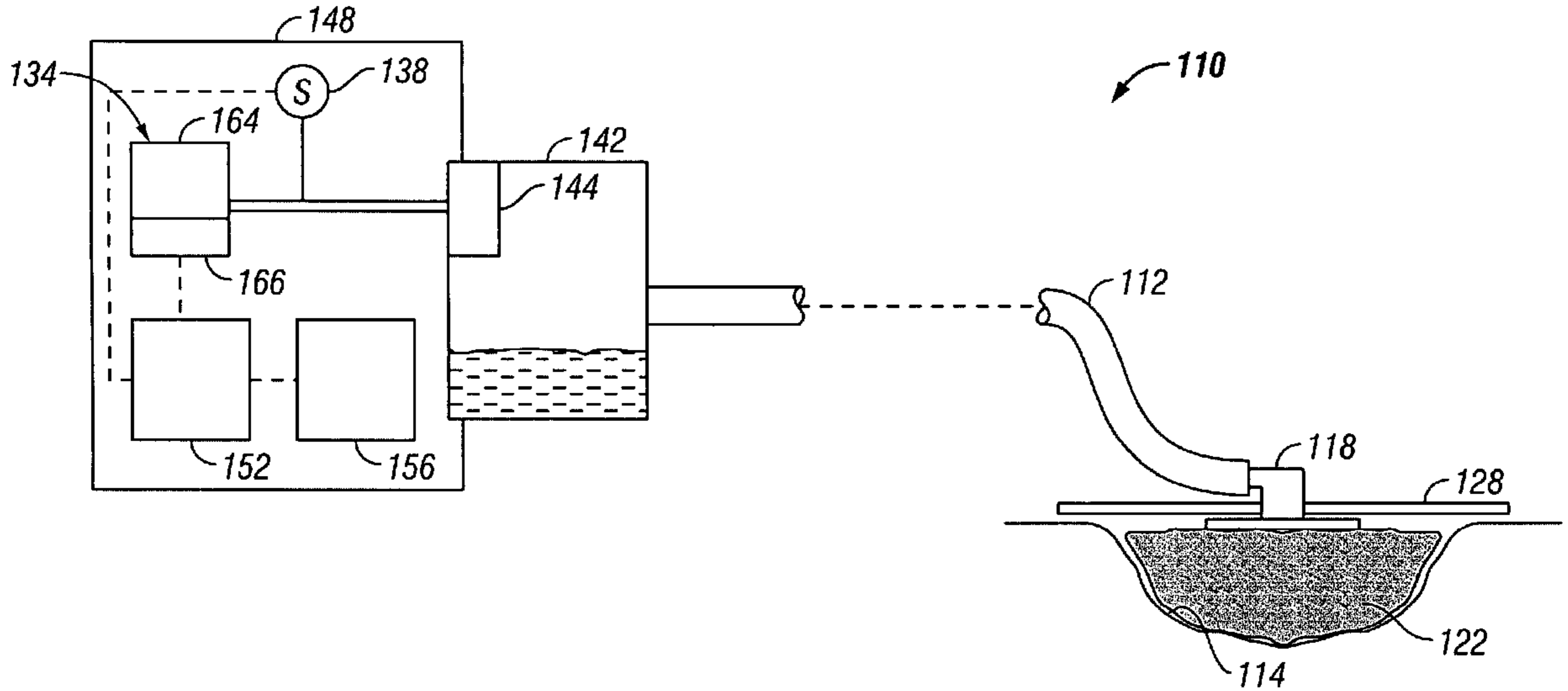

FIG. 1