

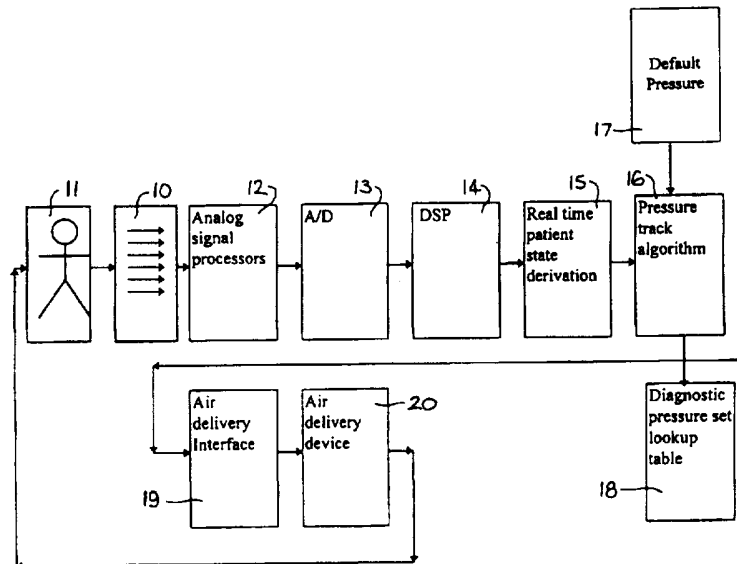

INTERNATIONAL APPLICATION PUBLISHED UNDER THE PATENT COOPERATION TREATY (PCT)

<p>(51) International Patent Classification ⁶ : A61M 16/00</p>	<p>A1</p>	<p>(11) International Publication Number: WO 97/16216 (43) International Publication Date: 9 May 1997 (09.05.97)</p>
<p>(21) International Application Number: PCT/AU96/00679 (22) International Filing Date: 31 October 1996 (31.10.96) (30) Priority Data: PN 6273 31 October 1995 (31.10.95) AU (71) Applicant (for all designated States except US): COM-PUMEDICS SLEEP PTY. LTD. [AU/AU]; 1 Marine Parade, Abbotsford, VIC 3067 (AU). (72) Inventor; and (75) Inventor/Applicant (for US only): BURTON, David [AU/AU]; 62 Broadway, Camberwell, VIC 3124 (AU). (74) Agent: PHILLIPS ORMONDE & FITZPATRICK; 367 Collins Street, Melbourne, Victoria 3000 (AU).</p>		<p>(81) Designated States: AL, AM, AT, AU, AZ, BA, BB, BG, BR, BY, CA, CH, CN, CU, CZ, DE, DK, EE, ES, FI, GB, GE, HU, IL, IS, JP, KE, KG, KP, KR, KZ, LC, LK, LR, LS, LT, LU, LV, MD, MG, MK, MN, MW, MX, NO, NZ, PL, PT, RO, RU, SD, SE, SG, SI, SK, TJ, TM, TR, TT, UA, UG, US, UZ, VN, ARIPO patent (KE, LS, MW, SD, SZ, UG), Eurasian patent (AM, AZ, BY, KG, KZ, MD, RU, TJ, TM), European patent (AT, BE, CH, DE, DK, ES, FI, FR, GB, GR, IE, IT, LU, MC, NL, PT, SE), OAPI patent (BF, BJ, CF, CG, CI, CM, GA, GN, ML, MR, NE, SN, TD, TG).</p> <p>Published With international search report.</p>

(54) Title: APPARATUS FOR GAS DELIVERY



(57) Abstract

Apparatus for controlling gas delivery to a patient, the delivery being adapted to maintain a physiological event such as effective respiratory function and/or absence of arousals. The apparatus includes means (10, 12, 13) for monitoring one or more physiological variables such as EEG, EOG, EMG, patient position and breathing associated with the patient. The apparatus also includes means (14, 15) for deriving from the variables, data representing physiological states of the patient corresponding to the variables and means (16, 17) for determining from the data for each physiological state, a gas pressure value beyond and below which there is a deterioration in the physiological event. The deriving means may include an automatic sleep staging algorithm (41) and the determining means may include a pressure seek algorithm.

FOR THE PURPOSES OF INFORMATION ONLY

Codes used to identify States party to the PCT on the front pages of pamphlets publishing international applications under the PCT.

AM	Armenia	GB	United Kingdom	MW	Malawi
AT	Austria	GE	Georgia	MX	Mexico
AU	Australia	GN	Guinea	NE	Niger
BB	Barbados	GR	Greece	NL	Netherlands
BE	Belgium	HU	Hungary	NO	Norway
BF	Burkina Faso	IE	Ireland	NZ	New Zealand
BG	Bulgaria	IT	Italy	PL	Poland
BJ	Benin	JP	Japan	PT	Portugal
BR	Brazil	KE	Kenya	RO	Romania
BY	Belarus	KG	Kyrgystan	RU	Russian Federation
CA	Canada	KP	Democratic People's Republic of Korea	SD	Sudan
CF	Central African Republic	KR	Republic of Korea	SE	Sweden
CG	Congo	KZ	Kazakhstan	SG	Singapore
CH	Switzerland	LI	Liechtenstein	SI	Slovenia
CI	Côte d'Ivoire	LK	Sri Lanka	SK	Slovakia
CM	Cameroon	LR	Liberia	SN	Senegal
CN	China	LT	Lithuania	SZ	Swaziland
CS	Czechoslovakia	LU	Luxembourg	TD	Chad
CZ	Czech Republic	LV	Latvia	TG	Togo
DE	Germany	MC	Monaco	TJ	Tajikistan
DK	Denmark	MD	Republic of Moldova	TT	Trinidad and Tobago
EE	Estonia	MG	Madagascar	UA	Ukraine
ES	Spain	ML	Mali	UG	Uganda
FI	Finland	MN	Mongolia	US	United States of America
FR	France	MR	Mauritania	UZ	Uzbekistan
GA	Gabon			VN	Viet Nam

APPARATUS FOR GAS DELIVERY

The present invention relates to apparatus for controlling gas delivery to a patient. The apparatus may provide a diagnostic and/or a therapeutic function.

5 The diagnostic function may include monitoring and/or diagnosis of physiological variables associated with the patient. The therapeutic function may include application of controlled gas delivery to the patient.

The apparatus of the present invention is particularly useful for investigation, diagnosis and treatment of sleep, respiratory and sleep related
10 respiratory disorders, sleep propensity and fatigue and will be described herein in that context. Nevertheless it is to be appreciated that it is not thereby limited to such applications.

Sleep apnea syndrome is a respiratory disorder affecting between 4 and 5% of the population and is now well documented in a number of reputable
15 medical journals. Sufferers of this debilitating disorder suffer reduced sleep efficiency, excessive blood pressure, cardiovascular effect ranging from mild to fatal, amongst other adverse health consequences and risks. It is recognised that an increase in upper airway resistance attributed to relaxation of upper airway muscles during sleep, contributes to cessation of breathing at frequent intervals
20 during an Obstructive Sleep Apnea (OSA) patient's sleep. OSA is now relatively well documented and understood within the respiratory and sleep medical fields.

In the early 1980's a development commonly referred to as Continuous Positive Air Pressure (CPAP) was discovered as a front line cure for OSA (Sullivan). CPAP is a device which applies a continuous positive air pressure to
25 the patient's airway by way of a nasal mask. This nasal mask is worn by the patient during sleep and a positive air pressure is applied to the patient's airway in order to keep the patients airway open and prevent a collapse of the patient's airway, which would otherwise lead to OSA.

Development of CPAP devices have been pursued by a range of
30 manufacturers across the world and a number of variations of CPAP have also been introduced to the market place. These variations include, inter alia:

- 2 -

Demand Positive Air Pressure (DPAP) which is a device that supplies positive air pressure by detecting the patients respiratory cycle and applies the air pressure when the patient 'demands' this;

Bi positive air pressure (BIPAP), which is a device that allows two states of positive pressure and monitors the patient's respiration and delivers air pressure depending on whether the patient is undergoing inspiration or expiration; and

Variable Positive Air Pressure (VPAP) which is a device that delivers a varying air pressure depending upon the patient's respiration cycle.

Other devices have been developed to automatically adjust air pressure delivered to a patient during sleep.

Whilst the prior art recognizes that respiratory disorders such as apnea or hypopnea may be addressed by applying positive air pressure to a patient, it has failed to recognize that even without the presence of respiratory events such as hypopnea or apnea (as detected or diagnosed by conventional means) upper airway resistance can exist and results in a reduction of a patient's sleep efficiency. The apparatus of the present invention may diagnose such upper airway resistance by detecting arousals. Arousals may be detected, for example, from a shift in frequency of the patients Electroencephalogram (EEG) and/or Electro-oculogram (EOG).

It is therefore recognised that even after treatment for OSA by application of the above mentioned CPAP or variations thereof, a patient can still experience arousals or micro-arousals during a night's sleep. These arousals and micro-arousals can be due in part to the fact that the air pressure required to be delivered to the patient to prevent OSA can vary depending upon the patients sleep position, sleep state and other factors such as intake of alcohol or drugs consumed prior to sleeping. The arousals and micro-arousals may be linked or associated with respiratory disorders

It has been shown that many arousals or micro-arousals can occur during a patient's sleep. The present invention may provide apparatus for monitoring the patient's physiological variables and to diagnose corresponding physiological states including sleep, arousal and respiration events while at the same time controlling delivery of gas to a patient via a nasal or nasal and oral mask. The

apparatus can in one mode be adapted to diagnose physiological states and in another mode adjust the pressure of air delivery to the patient to a level which accurately reflects the patient's state of wakefulness, sleep or arousal.

- Due to the complex and varying states of sleep and broad range of sleep disorders that can be diagnosed, many different physiological variables (raw data) and events (derived data) may be monitored and/or analysed. While some positive air pressure devices exist which can monitor respiratory parameters, the present applicant is not aware of any prior art device which is able to monitor and diagnose a comprehensive range of both sleep and respiratory parameters. The monitored variables/events can include one or more of the following:
- Electroencephalogram (EEG)
 - Electro-oculogram (EOG)
 - Electro-myogram (submental EMG from muscles under the chin)
 - Electro-myogram (diaphragm EMG from respiratory effort)
 - 15 • Electro-myogram (other EMG reflecting muscle and nerve activity either by invasive or non-invasive monitoring)
 - Status of patient position
 - Breathing and snoring sounds (via microphone)
 - Leg movements (Left and/or Right legs)
 - 20 • Electrocardiogram (ECG)
 - Oximetry ($S_a O_2$ - Oxygen saturation)
 - Carbon dioxide monitoring CO_2
 - Respiratory effort (Abdominal, thoracic or otherwise)
 - Airflow (Nasal or oral)
 - 25 • Continuous Positive Airflow Pressure (monitoring of patients mask pressure during application of CPAP treatment)
 - CPAP mask temperature (monitoring of CPAP mask air temperature for breathing activity and airflow of patient)

- 4 -

- CPAP mask sound (monitoring for patients breathing sounds within CPAP mask).
These sounds include snoring, wheezing and other disordered breathing sounds
- 5
- Status of lights
 - Graphic processing of video image (allows determination of whether patients eyes are open or closed).
 - Patient digital video recording and graphic processing techniques for determination of eye lid activity (ie status of patient eyes being opened or closed - relative to fully closed or fully opened eyes status).
- 10
- Time and date stamping of monitored physiological data, video and sound.
 - Infrared Video monitoring (for night studies)
 - Complex sound analysis (accurate full bandwidth or limited bandwidth recording and analysis of breathing sounds).
- 15
- Physiological events: ie ECG arrhythmia, EEG spike detection, EEG spindles amongst others
 - Endoscopy
 - Breath by breath analysis-pnuemotachograph
 - 3 D imaging
- 20
- Infrared eye detection for fatigue and sleep monitoring
 - EEG delta and alpha-wave detection
 - Delta Wave detections and related sleep/fatigue/impairment detection
 - Mattress Device: monitoring of patient sleep state and respiratory parameters by using a mattress sensor device. The mattress device can be used to
- 25
- monitor a patient's electro-oculogram, sleep state, arousals, position, electrocardiogram. There are presently two types commercially available mattress devices; Static Charge-sensitive Bed (SCSB) and polyvinylidene fluoride (PVDF- piezoelectric plastic).

30 The apparatus of the present invention may monitor and diagnose a patient's EEG, EMG, EOG, position, breathing/snoring sounds and other variables/events while at the same time control treatment such as positive air

pressure. The positive air pressure treatment may be adjusted dynamically to suit the patients prevailing:

- sleep state, respiratory events (ie OSA, central apnea, hypopnea, mixed apnea)
- 5 - position (different air pressure may be required depending upon the patient's sleep position),
- arousals status (ie micro arousals may occur due to insufficient or excessive pressure),
- snoring (varying degrees of pressure may be required depending upon the
- 10 patient's snoring - if for example the patient has taken alcohol or other drugs prior to their sleep, CPAP pressure may need to be varied in order to effectively eliminate snoring).

The apparatus of the present invention may deliver small or large adjustments in gas pressure delivery to the patient in order to maintain an

15 appropriate pressure at all times.

The apparatus of the present invention may operate in one of several modes. The apparatus may operate in a diagnostic mode in which patient variables and/or events are monitored, processed and recorded for later review. Processing of the variables/events may be performed in any suitable manner and

20 by any suitable means such as by means of a system as disclosed in AU Patent 632932 entitled "Analysis system for physiological variables", the disclosure of which is incorporated herein by cross reference. The diagnostic mode may include means for determining patient states. The latter may be derived from the monitored variables/events by means of one or more known automated sleep

25 staging methodologies. The diagnostic mode includes means for determining an appropriate gas pressure setting for each patient state. The latter may be carried out by means of a pressure setting algorithm and stored in a look-up table for recall during the treatment mode.

The apparatus may operate in a treatment only mode wherein pressure

30 settings determined during the diagnostic mode and stored in the look-up table may be applied to deliver gas to a patient according to the prevailing state of the patient as determined during the treatment mode.

The apparatus may operate in an integrated diagnostic and treatment mode wherein treatment via gas delivery is related to the currently monitored patient variables/events and diagnosed physiological states of the patient. The latter are determined in real time as part of the diagnostic mode.

5 A significant function of the diagnostic and integrated modes is to monitor the patient for micro-arousals. These micro-arousals can be detected from a change in frequency of the EEG and/or the EMG channels and/or by other means such as by detecting patient position/movement or by monitoring a mattress sensor device. By detecting the patient's micro-arousals, treatment of gas
10 delivery can be correctly verified as providing an appropriate gas delivery for the patient. This method of arousal monitoring may determine whether or not the patient is actually being treated and benefiting from optimal sleep efficiency during gas delivery treatment.

The apparatus includes means for monitoring one or more physiological
15 variables including EEG, EOG, EMG, patient position and breathing/snoring. The monitoring means may include one or more transducers adapted to monitor the relevant physiological variable(s) such as a microphone for monitoring breathing/snoring sounds, and to provide an analog signal output indicative of the monitored variable. The monitoring means may include one or more electrodes
20 applied to a part or parts of the body of the patient such as the skull, canthus, chin, legs etc. The monitoring means may also include means suitable for monitoring inter alia, oxygen saturation, CO₂ levels, respiratory effort, breathing and snoring sounds.

The apparatus includes means for analog processing the or each channel
25 or signal obtained by the monitoring means. The analog processing means may include means for preamplifying, conditioning and filtering the signal(s). The apparatus may include means for converting the processed signal(s) to a digital signal(s). The conversion may be carried out in any suitable manner and by any suitable means such as an analog to digital converter.

30 The apparatus includes means for processing the digital signal(s). The digital processing means may include a digital computer such a microprocessor or microcomputer. The digital processing means may be programmed via

suitable software means to derive from the monitored physiological variables, corresponding patient states and/or events. The processing means may make use of one or more algorithms to automatically derive the patient states and/or events.

5 The algorithm(s) may be adapted to derive, inter alia, hypopnea, obstructive apnea, central apnea and mixed apnea respiratory events, arterial oxygen desaturation (SaO_2), wake, arousal and REM sleep states, and stages 1, 2, 3 or 4 of sleep for each epoch. The number of epochs entered for each state may vary but should be sufficient to allow a measure of confidence for each
10 patient state. For example, if there were only one epoch of REM sleep considered stable, this may prompt a clinician to review the patient's data as there may be a case for further investigation due to a below normal occurrence of REM sleep. A sequence of patient states for each epoch may be derived via this process. Where a large range and types of variables are being monitored, the
15 processing means may be adapted to limit the number of patient states, or combination of states which may be recognised in order to simplify configuration options and system use. The states/combinations available may depend upon the end use of the apparatus eg. whether the apparatus is intended to be used as a routine clinical tool or a research device.

20 The apparatus may include means for determining an appropriate gas delivery pressure for each patient state and/or context of patient states or combinations thereof. The context may refer to a current combination of states or preceding states or combinations thereof. The pressure determining means may include means for increasing pressure in the event that a deterioration in
25 respiratory event such as snoring, $S_a O_2$ desaturation, obstructive apnea, mixed apnea, central apnea, hypopnea or the like is detected. The pressure may continue to be increased until the event ceases, subject to a recommended maximum pressure not being exceeded. To more accurately establish a target pressure value wherein an increase in gas pressure ceases to cause
30 improvement in effective breathing, it may be desirable to slightly overshoot the target value. Pressure may then be reduced upon detecting that a monitored event has deteriorated. The apparatus may also include means for detecting

central apnea events triggered by the brain. In central apnea events gas delivery pressure changes may have little or no effect on a patient's respiratory function. It is therefore desirable to establish a central apnea condition before responding excessively to a respiratory event.

5 In one form the digital processing means may be programmed via suitable software to determine from each patient state and/or their contexts a gas pressure value beyond and below which there is a deterioration in a monitored event. The means for determining the appropriate gas delivery pressure may include a pressure seek algorithm. The algorithm may ensure that pressure to a
10 patient is tracked up or down until it is appropriate for a prevailing event such as a stage of sleep. The algorithm may also ensure that the state of the patient is stable before recording a pressure value for the prevailing epoch. A table of pressure values for each patient state may be derived by this process. The table may indicate the number of epochs associated with a particular pressure value or
15 values. It is expected that readings over several epochs will cluster around a narrow range of pressure values for each patient state.

 The table may be stored in a memory associated with the processing means. The memory may be on board the apparatus or it may be located remotely from the apparatus and connectable thereto via any suitable means
20 such as a telecommunication line and modem. In one form the remote memory may include a portable carrier such as a magnetic or smart card.

 A process of seeking an appropriate gas delivery pressure values may be commenced with a default or manually entered value for each patient state. Values may be entered manually by a physician either locally or remotely.
25 Default values may be determined from clinical trials. The default and manually entered values may be entered in a table of default pressure values.

 Where the apparatus is to be operated in an integrated diagnostic and treatment mode, pressure values which are determined by the pressure seek algorithm may be used to control in real time a gas delivery device via a suitable
30 interface. The gas delivery device may comprise a CPAP device or other externally controllable gas or air flow delivery unit. The pressure values which are

determined by the pressure seek algorithm may be entered in a pressure set look-up table and retained for future use.

Where the apparatus is to be operated in a treatment mode, the pressure values which are stored in the pressure set look-up table may be accessed
5 following patient state determination. The values entered in the pressure set look-up table may be used to control directly a gas delivery device. During treatment mode, pressure values appropriate to each patient state determined during the integrated diagnostic mode may be used. This may enable direct treatment of a patient where pressure values appropriate to each patient state
10 have previously been determined for that patient.

Where the apparatus is to be operated in a diagnostic mode, data representing patient states derived from the monitored physiological variables may be recorded for later recall and review.

According to one aspect of the present invention there is provided
15 apparatus for controlling gas delivery to a patient, said delivery being adapted to maintain a physiological event such as effective respiratory function and/or absence of arousals, said apparatus including:

means for monitoring one or more physiological variables associated with said patient;

20 means for deriving from said one or more variables, data representing physiological states of said patient corresponding to the or each variable; and

means for determining from said data for each physiological state, a gas pressure value beyond and below which there is a deterioration in said event.

According to a further aspect of the present invention there is provided a
25 method for controlling gas delivery to a patient, said delivery being adapted to maintain a physiological event such as effective respiratory function and/or absence of arousals, said method including the steps of:

monitoring one or more physiological variables associated with said patient;

30 deriving from said one or more variables, data representing physiological states of said patient corresponding to the or each variable; and

determining from said data for each physiological state, a gas pressure value beyond and below which there is a deterioration in said event.

A preferred embodiment of the present invention will now be described with reference to the accompanying drawings wherein:-

5 Fig. 1 shows a block diagram of apparatus according to one embodiment of the present invention;

Fig. 2 shows a block diagram of the apparatus according to another embodiment of the present invention;

10 Figs. 3a and 3b show a flow chart of one form of patient state table determining algorithm according to the present invention;

Fig. 4 shows one form of a patient state table with 11 epoch examples;

Figs. 5a and 5b show the general structure of one form of automatic sleep staging algorithm and an algorithm for evaluating probabilities of wake and sleep;

15 Figs. 6a and 6b show a flow chart of one form of gas pressure seek algorithm according to the present invention;

Figs. 7a and 7b show one form of a pressure set look up table according to the present invention;

Fig. 8 shows one example of diagnostic monitoring modes according to the present invention;

20 Figs. 9a and 9b show a flow chart of another form of gas pressure seek algorithm according to the present invention;

Fig. 10 shows a simplified patient state table; and

Fig. 11 shows one form of default pressure table.

25 Referring to Fig. 1, patient interface means 10 is adapted to monitor a plurality of physiological variables associated with a patient 11. Patient interface means 10 includes one or more electrodes and/or transducers adapted to monitor, inter alia, EEG, EMG, EOG, patient position and breathing to provide at their respective outputs analog signals indicative of the variables being monitored. A separate channel may be provided for each variable being
30 monitored. The analog output signals of patient interface means 10 are inputted to analog signal processing means 12. Analog processing means 12 includes one or more signal amplifiers, filters etc. for preamplifying and preconditioning the

signals to an appropriate bandwidth and amplitude level to provide a suitable input to analog to digital (A/D) converter means 13. A/D converter means 13 may include one or more A/D converters and is adapted to convert the analog processed signals to digital data. A/D converter means 13 may digitise each analog channel at a sampling rate suitable for that particular channel's signal and to a format which can be read by digital signal processing means 14. Digital processing means 14 includes a microprocessor or microcomputer and is adapted to accept digital data from A/D converter means 13.

Digital processing means 14 includes means 15 for deriving from the digital data, patient states/events corresponding to the monitored variables such as sleep stage 1, 2, 3, 4, PLM, arousal state, respiratory event, etc., during each epoch. Each epoch may be defined by a time segment having a set duration eg. 20 to 30 seconds. The patient state deriving means 15 may include an automatic sleep staging algorithm. After determining which channels of data are being presented (ie. which physiological variables are being monitored) the sleep staging algorithm may derive in real time the prevailing patient state and enter this in a patient state table. In deriving the prevailing patient state, means 15 may take into account both real time data from the physiological channels being monitored as well as the context of the data ie. the context of the prevailing patient state/event being evaluated with reference to preceding states.

Digital processing means 14 implements a pressure seek algorithm 16 to determine for a prevailing patient state and its context an appropriate gas pressure value for that prevailing state. The pressure seek algorithm 16 may include an iterative process to determine the appropriate pressure value. The process may include increasing pressure if a respiratory event such as snoring, S_aO_2 desaturation, obstructive apnea or hyponea is detected until the event ceases, thereby providing an effective improvement in breathing. Pressure may initially be increased from a clinically predetermined default value entered in default pressure table 17 or a value set by an attending physician. Figure 11 shows one form of default pressure table. To more accurately determine an appropriate pressure value a slight increase in pressure may be applied after an event ceases. The pressure may then be reduced until the event ceases and

stabilizes. The resultant pressure value may then be entered into a pressure set look-up table 18.

The process may be repeated over many epochs and the results stored in a memory such as look up table 18. The memory may include a remote device
5 such as a magnetic carrier or smart card. Where the apparatus is being used in a diagnostic only mode, data stored in look up table 18 may be used for future reference or in a treatment only mode. Where the apparatus is being used in an integrated diagnostic and treatment mode, the output from pressure seek algorithm 16 is used to control in real time air delivery interface 19 associated with
10 air delivery device 20, such as a CPAP or other externally controlled gas or air flow delivery device.

Fig. 2 shows the apparatus of Fig. 1 being used in a treatment mode. In Fig. 2 gas pressure values appropriate for each patient state are not determined in real time by pressure seek algorithm 16 but are instead read from pressure set
15 look-up table 18, as determined and stored during a prior integrated diagnostic and treatment mode.

Figs. 3a and 3b show a flow diagram of one form of patient state deriving means 15. Digital data representing EEG, EMG, EOG and patient movement is inputted to modules 30 to 39. Modules 30 to 39 process the data to extract
20 information required by sleep staging algorithm 41. The information processed includes an EEG histogram calculated using zero-crossing half-period analysis, "probabilities" of sleep and wake for the epoch (the "probability" of sleep in this context relates to delta and theta components), number of spindles, number of K-complexes, average EEG amplitude, relative average amplitude of EEG alpha, sigma and beta components (the purpose of this characteristic is to provide
25 correct information about the high frequency EEG components when it is distorted by zero-crossing period amplitude analysis), number of arousals, average EMG amplitude, and REM analysis.

The output from sleep staging algorithm 41 is inputted to the patient state table determining algorithm shown in the flow chart of Fig. 3b. The outputs of the
30 latter algorithm marked "STATE 1" to "STATE 20" are stored in a patient state table, an example of which is shown in Fig. 4.

Figs. 5a and 5b show one form of automatic sleep staging algorithm 41. Such algorithms are known in the art and will not be described in detail herein. Fig. 5a shows the general structure of the sleep staging algorithm 41 and Fig. 5b shows a syntactic algorithm for evaluating probabilities of wake and sleep.

5 Figs. 6a and 6b show a flow chart of an algorithm for determining appropriate gas pressure based on patient state. Real time patient state is derived at step 60 by patient state deriving means 15. Step 61 enters an initial pressure value for the particular patient state from default pressure table 17. Step 62 reads real time patient state information from patient state deriving
10 means 15. Step 63 performs a test to establish whether the patient sleep state is stabilizing. This may be determined by events decreasing in frequency ie. by a reduction in occurrence of apneas, hypopneas, desaturations and/or arousals or by a patient's sleep state remaining constant or changing to a deeper stage of sleep, eg. stage 4 to REM, stage 1 to 2, stage 2 to 3, stage 3 to 4 and
15 accompanied by a reduction in movement time. If the determination is no (N) pressure is increased or decreased (steps 67-68), the patient variables are reprocessed (step 69) and the algorithm returns to steps 62 and 63. If the determination is yes (Y), step 64 performs a test to establish whether the rate of sleep state stabilization is appropriate. The latter is appropriate if it is occurring at
20 a rate determined by clinical trials. If the determination is no (N) pressure is increased or decreased (steps 67-68), the patient variables are reprocessed (step 69) and the algorithm returns to steps 62 to 64. If the determination is yes (Y), step 65 performs a test to establish whether the patient respiratory state is stabilizing. As noted above this may be determined by events decreasing in
25 frequency. If the determination is no (N) pressure is increased or decreased (steps 67-68), the patient variables are reprocessed (step 69) and the algorithm returns to steps 62-65. If the determination is yes (Y) step 66 performs a test to establish whether the rate of respiratory stabilization is appropriate. The latter is appropriate if the reduction in frequency or severity of the respiratory event is
30 occurring at a rate determined by clinical trials. If the determination is no (N) pressure is increased or decreased (steps 67-68), the patient variables are reprocessed (step 69) and the algorithm returns to steps 63 to 66. If the

determination is yes (Y) the air pressure is stored in pressure set look-up table 18.

Figs. 7a and 7b show one example of a pressure set look-up table. The numbers at the top of the table represent the epochs (each epoch is selectable to
5 a 20 or 30 second time period) for each specific state and gas delivery. A table similar to Figs. 7a and 7b can be created for each and every diagnostic study. Stages 1, 2, 3, 4 and REM may be listed where the patient state is considered stable, eg. the incidence of respiratory events, arousals and micro-arousals are at a minimum that can be archived with optimal pressure (achieved by tracking
10 above and below what is considered as optimal). Arousal, micro-arousal, wake and movement time are listed because the patient may wake, arouse or move due to external factors such as noise disturbance. The apparatus may apply an air pressure during these incidences which is most compatible with such an occurrence. This pressure may, for example, be an optimal pressure for stage 1,
15 which most closely represents pressure in preparation for the first stage of sleep.

The pressure seek algorithm may ensure that pressure to the patient is tracked up and down and that the patient state is stable before the pressure value is noted into a particular epoch. A list of epochs where the pressure is considered "non-stable" may also be noted to allow validation and reply of the
20 patient's diagnostic study for verification of data recorded during diagnostic operation of the apparatus.

The numbers of epochs entered for each state allow a measure of confidence for each patient state. If for example, there were only one epoch of REM sleep considered stable, this may prompt the clinician to review the patient's
25 data as there may be a case for further investigation due to a below normal occurrence of REM sleep.

The table of Figs. 7a and 7b represents the diagnostic output for a study but this table could be substituted for a single column of optimum pressure reading against each patient state. Alternatively the patient may be "calibrated"
30 for different of types of study such as when the patient has had alcohol or other drug treatment. In these cases the patient may configure the apparatus to represent their condition from a range of options which may be calibrated for a

particular patient. After sufficient clinical data is available it may be possible to extrapolate various conditions or other tables of pressure values from the patient's standard data, rather than having to conduct separate studies when the patient has had drugs administered or is excessively tired or is under the influence of other causes that could significantly affect the patient's gas delivery requirements.

The last columns of Fig. 7a and 7b show an example of default pressure settings. These default settings may be preset in the apparatus or determined by a supervising medical practitioner or healthcare worker.

Only the first two rows of the table have been filled in to serve as an example of the format of table. The default table may consist of a left hand state column plus several options of defaults depending on patient category - eg. severe apnea suspect etc.

In Fig. 7a it is apparent that during stage 1 sleep a pressure setting equal to 8.5 cm H₂O was recorded during 20 epochs whilst the patient was on his back (B) and during stage 2 sleep a pressure setting equal to 9 cm H₂O was recorded during 20 epochs. These are the appropriate pressure values for stages 1, 2 when the patient is lying on his back. Therefore these values are shown entered in the column marked opt val (optimum value). These are also the values which will be recalled in a treatment only mode.

Fig. 8 shows a chart of some combinations of monitoring modes that may be made available to an end-user to simplify system use and configuration options. The modes available will depend on whether the present invention device is to be used as a routine clinical tool or a research device. Other factors that may determine what modes are available to end user include marketing factors - ie what the market requires in terms of end user options. The chart shows the optional minimum configurations for the various modes (1 to 16).

The key to monitoring modes 1-16 is as follows:

MODE KEY FUNCTION

30	1	W -	represents wake state monitoring
	2	S -	represents sleep state monitoring
	3	A -	represents arousal state monitoring

- 16 -

	4	R -	represents respiratory state monitoring
	5	WS -	represents wake and sleep state monitoring
	6	WA -	represents wake and arousal state monitoring
	7	WR -	represents wake and respiratory state monitoring
5	8	SW -	represents sleep and wake state monitoring
	9	SA -	represents sleep and arousal state monitoring
	10	SR -	represents sleep and respiratory state monitoring
	11	AS -	represents arousal and sleep state monitoring
	12	AR -	represents arousal and respiratory state monitoring
10	13	WSA	represents wake, sleep and arousal state monitoring
	14	WSR	represents wake, sleep and respiratory state monitoring
	16	WSAR	represents wake, sleep, arousal and respiratory state monitoring

15 For modes 5 to 16 the wake, sleep, arousal and respiratory modes can be combined according to the mode type, eg. WR (mode 7) means that the configuration for wake and respiratory are combined. The above modes are minimal configurations only and numerous other combinations are available. For example the respiratory mode shows a single channel being used for each mode

20 illustrated but in fact any combination of the channels marked under respiratory mode can be used for the respiratory mode.

Figures 9a and 9b show a flow chart of a gas pressure seek algorithm with added refinements. Steps 1 to 35 of the flow chart are described below.

25 **STEP 1**

"Turned on" refers to apparatus being in active mode. This does not necessarily mean that the apparatus is operating a gas delivery mode but at least is in a standby or power on-mode ready for a clinician or patient to select start.

30 **STEP 2.**

Auto event/state start may be selected to avoid patient discomfort during gas delivery, eg. when the patient is not yet in a sleep state or when the patient is not

in a sleep state and requires gas delivery due to occurrence of a respiratory event.

STEP 3

After start is selected the apparatus will;

- 5 a) immediately start gas delivery to patient, or
- b) start gas delivery to patient when a pre-configured sleep state(s) is detected, or;
- c) start gas delivery to patient when a pre-configured respiratory event(s) is detected, or;
- 10 d) start gas delivery to patient when a pre-configured arousal type(s) is detected, or;
- e) start gas delivery to patient when a pre-configured periodic leg movement is detected.

15 STEP 4

Auto time start allows the apparatus to be switched on to gas delivery at a certain presented time. Auto-start may be selected concurrently with auto sleep/event start and the apparatus will start gas delivery after a set time and when a set state is detected.

20

STEP 5

The apparatus provides a means for automatically scanning physiological input variables from a patient and determines;

- a) whether the data is typical and accurate;
- 25 b) whether the data is affected by some form of artefact or other distortion and alerts the system user or operator;
- c) what the artefact or other distortion is, and if possible automatically compensates for the artefact or distortion, eg. by way of filtering or gain change, switching to backup or secondary electrodes or sensors or by other means.

30

STEP 6

This step refers to applying an automatic channel integrity scan and determining which channels are valid and then using valid channel combinations to determine a valid diagnostic mode selection.

5

This automatic diagnostic mode selection can also be set for continuous update so that valid channels are reviewed during the patient diagnostic mode. The valid diagnostic mode can be reviewed to ensure that any channels that have dropped out or are no longer valid can be compensated for by an appropriate diagnostic mode (refer to Fig. 8 for a table of appropriate diagnostic modes). The diagnostic mode will be selected by determining valid input channels and then selecting a mode that has at least the minimum valid channels as listed in the diagnostic mode table.

10

15 If the operator selects only airflow from the mask feed as a means of patient data input and the automatic Diagnostic mode is selected, the apparatus will scan the input data if auto input data scan is selected and determine that the airflow mask channel is valid and will automatically select the diagnostic Respiratory event detection and possibly arousal detection only. Arousal may be deduced by
20 determining an artefact signal riding on the airflow waveform.

STEP 7

Start gas delivery when pre-selected state is detected.

25 **STEP 8**

This mode can be selected on for start of a study only to determine valid channels or for "study mode on" where the input data will be scanned during study to ensure that input channels remain valid.

30 This can be achieved by selecting a mode type (ie selecting one of the configurations for combination of sleep, wake, respiratory or arousal monitoring - refer Fig. 8). By selecting one of the mode types the apparatus will indicate which parameters for the particular mode are required to be monitored from the patient.

Alternatively, a user can select channels that are required to be monitored and the apparatus may then automatically decide which diagnostic mode should be operated.

5 **STEP 9**

Input data integrity scan is a function which allows the input channels to be scanned for the purpose of determining whether the signal characteristics of these input channels are appropriate to indicate that the patient data is of suitable quality for further diagnostic processing.

10

For example the EEG, EOG and EMG electrodes can be scanned and analysed with reference to signal to noise ratio, frequency and amplitude characteristics in order to ensure that these parameters are within a normal range for a useable patient data channel. If, for example, the signal to noise ratio is excessively high
15 for a particular channel or the frequency component of a channel consists of mains electro magnetic frequency, then this channel is likely to be either not connected or have a poor connection to the subject under diagnosis. It is therefore better to not use this patient data channel rather than risk inferior diagnosis of the patient.

20

Another means of scanning patient input data for verification of signal quality may be to evoke an impedance checking function. The impedance checking function may inject a small, safe, current through the patient's electrodes and if the patient electrode contact is poor then the current will produce a higher voltage indicating
25 that the patient electrode may be in poor contact.

This type of input channel verification is normally evoked automatically by the apparatus, during a patient's use thereof. In this way signal integrity and subsequent gas delivery control is able to be continually verified for accuracy
30 against patient variables. It is quite common for electrodes and sensors to come loose or develop poor connections during the night, while a patient is being monitored. It is desirable that the apparatus is able to compensate for this factor

- 20 -

and to have sufficient intelligence not to incorrectly diagnose a patient through corrupt data from poor patient connections.

5 Another function of this step is to determine which patient channels are to be used for patient state derivation. The apparatus can in some embodiments be configured with as little as one channel of data being input. This channel could be an airflow channel, for example, as determined by sensing an airflow path provided by a gas delivery device to a patient.

10 The apparatus may use conventional pneumotachograph data analysis and representation for monitoring patient's airflow and respiratory disorders or events.

This step can be run automatically during study in order to verify quality of input signals and if necessary diagnostic mode can be automatically changed to
15 compensate for patient data channels which may not be of suitable quality to achieve accurate and reliable patient diagnostic treatment.

STEP 10

Valid input channels can be selected by the system user. Alternatively valid input
20 channels can be automatically detected by the apparatus in step 7. The apparatus will dynamically scan and update the valid mode in accordance with scanned valid channels.

STEP 11

25 This step notes valid channel types and the subsequent valid mode for patient state and event determination. This information may be used in later stages of patient diagnostic state and event determination.

STEP 12

30 Valid Sleep Determination mode may be activated if the operator of the apparatus has selected this mode or if the automatic mode select function is activated at step 6 and input data scan detects at least the minimum configuration of input channels for sleep diagnostic mode.

STEP 13

If the Sleep diagnostic mode is activated the sleep state determination algorithm may be activated.

5 **STEP 14**

Valid Respiratory Determination mode may be activated if the operator of the apparatus has selected this mode or if the automatic mode select function is activated in step 6 and input data scan detects at least a minimum configuration of input channels for Respiratory diagnostic mode.

10

STEP 15

If the Respiratory diagnostic mode is activated a respiratory event determination algorithm may be activated.

15 **STEP 16**

Valid Arousal Determination mode may be activated if an operator of the apparatus has selected this mode or if the automatic mode select function is activated at step 6 and input data scan detects at least a minimum configuration of input channels for the Arousal diagnostic mode.

20

STEP 17.

If the arousal diagnostic mode is activated an arousal state determination algorithm may be activated.

25 **STEP 18.**

It is unlikely that the apparatus will not detect a valid mode as even the patient mask application allows the system to determine that the airflow sensor or the mask pressure sensor is a valid signal. In the case of a mask airflow signal only, for example, the apparatus may operate in a respiratory diagnostic mode.

30

One case where a valid diagnostic mode may not be detected is when the apparatus is turned on and the mask is not connected. In this case the airflow

- 22 -

signal may be scanned and determined as invalid, in which case a continuous pressure may be applied to the mask until automatic signal validation determines that the airflow signal becomes valid when the patient applies the mask.

- 5 A default pressure applied to the patient's mask may be determined either by an attending physician or clinical data.

STEP 19.

- 10 Figure 10 shows a simplified table logging patient sleep state, respiratory event and arousal event for the first 10 epochs of a diagnostic mode operation.

STEP 20.

- 15 The pressure value is noted before any seek routines are implemented so that a pressure value can be returned to in case, for example, the seek routine does not affect the patient respiratory or arousal events.

STEP 21.

Is start or continuation of respiratory instantaneous event detected.

Refer FIG 1 means 15

20

STEP 22.

Is start or continuation of arousal event detected?

STEP 23.

- 25 Run instantaneous pressure seek algorithm, ie increment gas delivery at rate X, to patient. Enter pressure value X for determination of the rate of increase for pressure seek adjustment. The value of X may be determined from clinical studies which may be established to determine an effective value of pressure rate change for the purpose of optimising the patient's state.

30

STEP 24.

Has patient safety pressure limit been exceeded?

Value Y represents a maximum pressure that can be applied to a patient. This value may be determined individually for different patients or may be a common value for a number of patients. Clinical trials may assist in determination of this value.

5

STEP 25.

Are symptoms of the start or continuation of respiratory and/or arousal events being reduced ?

The patient data needs to be continually monitored during pressure seek control
10 to ensure that pressure changes assist in ceasing respiratory and/or arousal events.

STEP 26.

Back off gas delivery pressure to a minimum pressure level required to avoid
15 event symptom(s), ie. note pressure from step 20. This step ensures that excessive pressure is not supplied to the patient but rather that a minimum value of pressure is applied to stabilise the patient's state.

STEP 27.

20 Stop instantaneous gas delivery pressure seek mode. This step prevents an increase in pressure where the pressure has corrected the arousal or respiratory event or a recommended maximum pressure is exceeded.

STEP 28.

25 Longer term seek algorithms are required to determine whether a patient sleep can be improved by optimising patient gas delivery.

Some diagnostic evaluations conducted by means 15 (Fig. 1) in order to determine "appropriate" longer term pressure changes include:

30

- 24 -

- a) is patient sleep state remaining constant or changing to deeper stage of sleep, eg. stage 4 to REM, stage 1 to 2, stage 2 to 3, stage 3 to 4, reduction in movement time;
- 5 b) "appropriate" denotes that the rate that the rate at which sleep stages change into a deeper stage of sleep occur at an ideal rate, where the ideal rate may be determined by clinical trials;
- c) "appropriate" also denotes that the reduction in frequency or severity of the
10 respiratory event is occurring at an ideal rate, where the ideal rate may be determined by clinical trials;
- d) determination of patient state stabilising including detection of:
events decreasing in frequency ie reduction in occurrence of apneas,
15 hypopneas, desaturations and/ or arousals.

STEP 29.

Is start or continuation of respiratory event trend detected?

Refer FIG 1 means 15

20

STEP 30.

Is start or continuation of arousal event trend detected?

STEP 31.

- 25 Run long term pressure seek algorithm, ie. increment gas delivery at rate Z, to patient. Enter pressure value Z for determination of rate of increase for pressure seek adjustment. The value of Z may be determined from clinical studies which may be established to determine an effective value of pressure rate change for the purpose of optimising the patient's state.

30

STEP 32.

Has patient safety pressure limit been exceeded?

Value W represents a maximum pressure that can be supplied to the patient. This value may be determined individually for different patients or may be a common value for a number of patients. Clinical trials may assist in determining this value.

5

STEP 33.

Are symptoms of start or continuation of respiratory and/or arousal events trend being reduced ?

10 The patient data needs to be continually monitored during pressure seek control to ensure that pressure changes assist in ceasing respiratory and/or arousal events.

STEP 34.

15 Back off gas delivery pressure to ensure that a minimum pressure level is determined to avoid event symptom(s), ie. note pressure from step 20. This step ensures that excessive pressure is not supplied to the patient but rather that a minimum value of pressure is applied to stabilise the patient's state.

STEP 35.

20 Stop long term gas delivery pressure seek mode. This step prevents an increase in pressure where the pressure has corrected the arousal or respiratory event or a recommended maximum pressure value is exceeded.

25 Finally, it is to be understood that various alterations, modifications and/or additions may be introduced into the constructions and arrangements of parts previously described without departing from the spirit or ambit of the invention.

CLAIMS

1. Apparatus for controlling gas delivery to a patient, said delivery being adapted to maintain a physiological event such as effective respiratory function
5 and/or absence of arousals, said apparatus including:
 means for monitoring one or more physiological variables associated with said patient;
 means for deriving from said one or more variables, data representing physiological states of said patient corresponding to the or each variable; and
10 means for determining from said data for each physiological state, a gas pressure value beyond and below which there is a deterioration in said event.
2. Apparatus according to claim 1 wherein said physiological variables include EEG, EOG, EMG, patient position and breathing.
3. Apparatus according to claim 1 or 2 wherein at least one of said means for
15 deriving and said means for determining is provided via digital processing means.
4. Apparatus according to claim 1, 2 or 3 wherein said deterioration is detected by said deriving means.
5. Apparatus according to any one of the preceding claims wherein said deriving means includes an automatic sleep staging algorithm.
- 20 6. Apparatus according to any one of the preceding claims wherein said deriving means includes means for evaluating sleep and/or arousal states.
7. Apparatus according to any one of the preceding claims wherein said deriving means includes means for detecting micro arousals.
8. Apparatus according to any one of the preceding claims wherein said
25 deriving means includes means for detecting respiratory events.
9. Apparatus according to any one of the preceding claims wherein said determining means includes a pressure seek algorithm.
10. Apparatus according to any one of the preceding claims wherein said data is derived during respective epochs of a monitored period and is stored in a
30 patient state table.
11. Apparatus according to claim 10 wherein said determined gas pressure values are stored in a pressure set look-up table.

12. Apparatus according to claim 10 or 11 when appended to claim 3 wherein said table is stored in a memory associated with said digital processing means.
13. Apparatus according to claim 12 wherein said memory includes a portable carrier.
- 5 14. Apparatus according to any one of the preceding claims including a gas delivery means for delivering gas to said patient in accordance with said determined gas pressure values.
15. Apparatus according to claim 14 wherein said gas delivery means includes a CPAP device.
- 10 16. A method for controlling gas delivery to a patient, said delivery being adapted to maintain a physiological event such as effective respiratory function and/or absence of arousals, said method including the steps of:
- monitoring one or more physiological variables associated with said patient;
- 15 deriving from said one or more variables, data representing physiological states of said patient corresponding to the or each variable; and
- determining from said data for each physiological state, a gas pressure value beyond and below which there is a deterioration in said event.
17. A method according to claim 16 wherein said variables include EEG, EOG,
- 20 EMG, patient position and breathing.
18. A method according to claim 16 or 17 wherein said deterioration is detected during said deriving step.
19. A method according to claim 16, 17 or 18 wherein said deriving step includes an automatic sleep staging algorithm.
- 25 20. A method according to any one of claims 16-19 wherein said deriving step includes a step of evaluating sleep and/or arousal states.
21. A method according to any one of claims 16-20 wherein said deriving step includes a step of detecting micro-arousals.
22. A method according to any one of claims 16-21 wherein said deriving step
- 30 includes a step of detecting respiratory events.
23. A method according to any one of claims 16-22 wherein said determining step includes a pressure seek algorithm.

- 28 -

24. A method according to any one of claims 16-23 wherein said data is derived during respective epochs of a monitored period and is stored in a patient state table.
25. A method according to claim 24 wherein said determined gas pressure values are stored in a pressure set look-up table.
26. A method of delivering gas to a patient including a method for controlling said delivery according to any one of claims 16-25.
27. Apparatus for controlling gas delivery to a patient substantially as herein described with reference to the accompanying drawings.
- 10 28. A method for controlling gas delivery to a patient substantially as herein described with reference to the accompanying drawings.

FIG 1

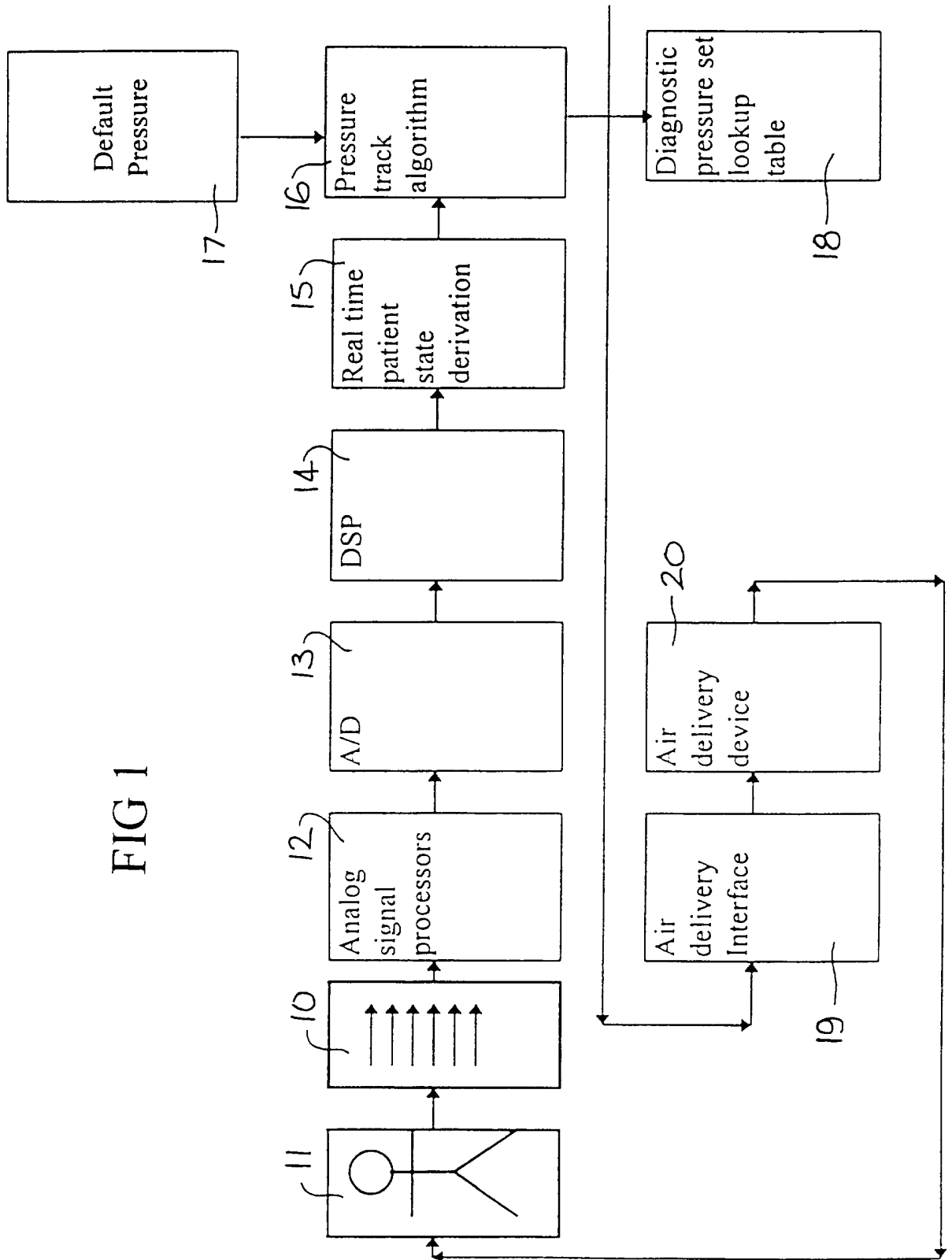

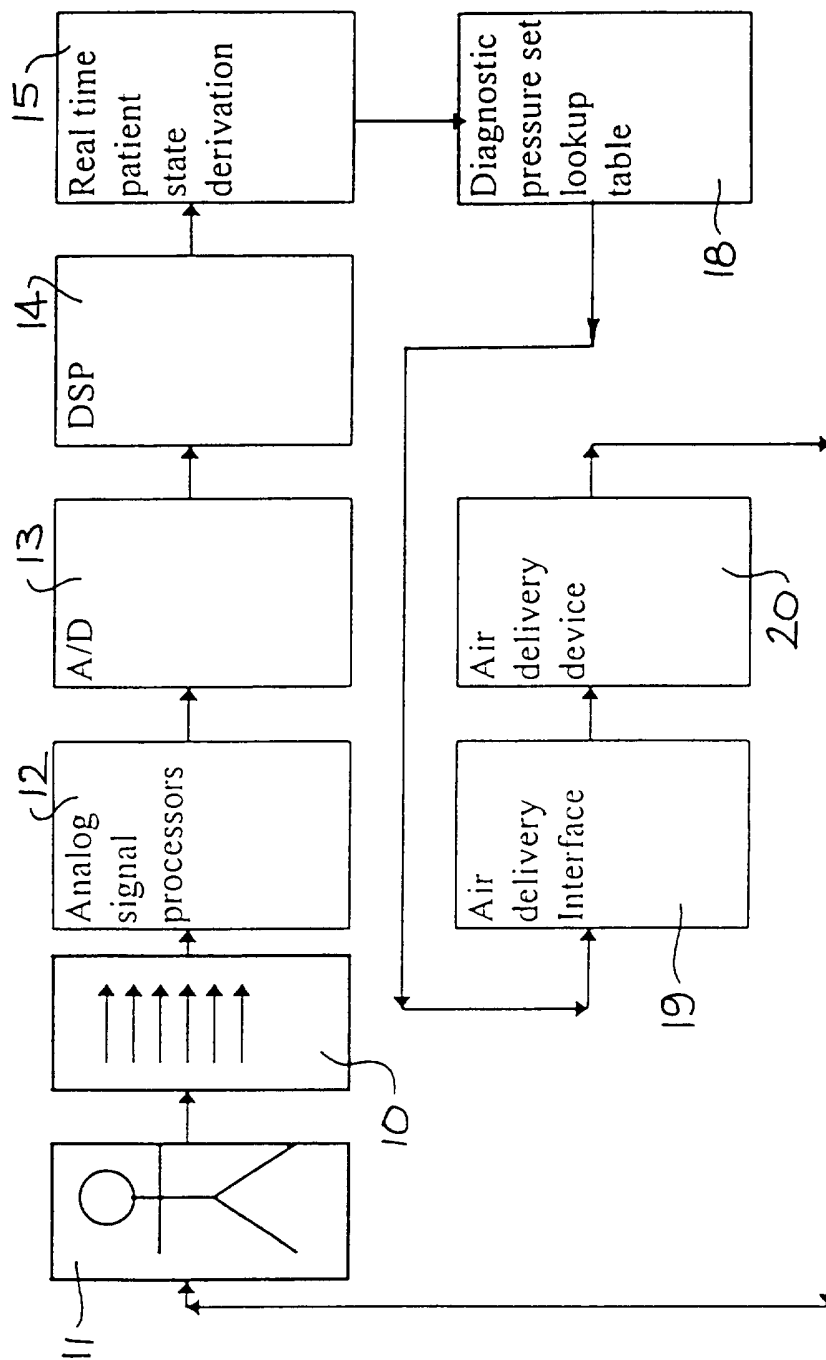

FIG 2

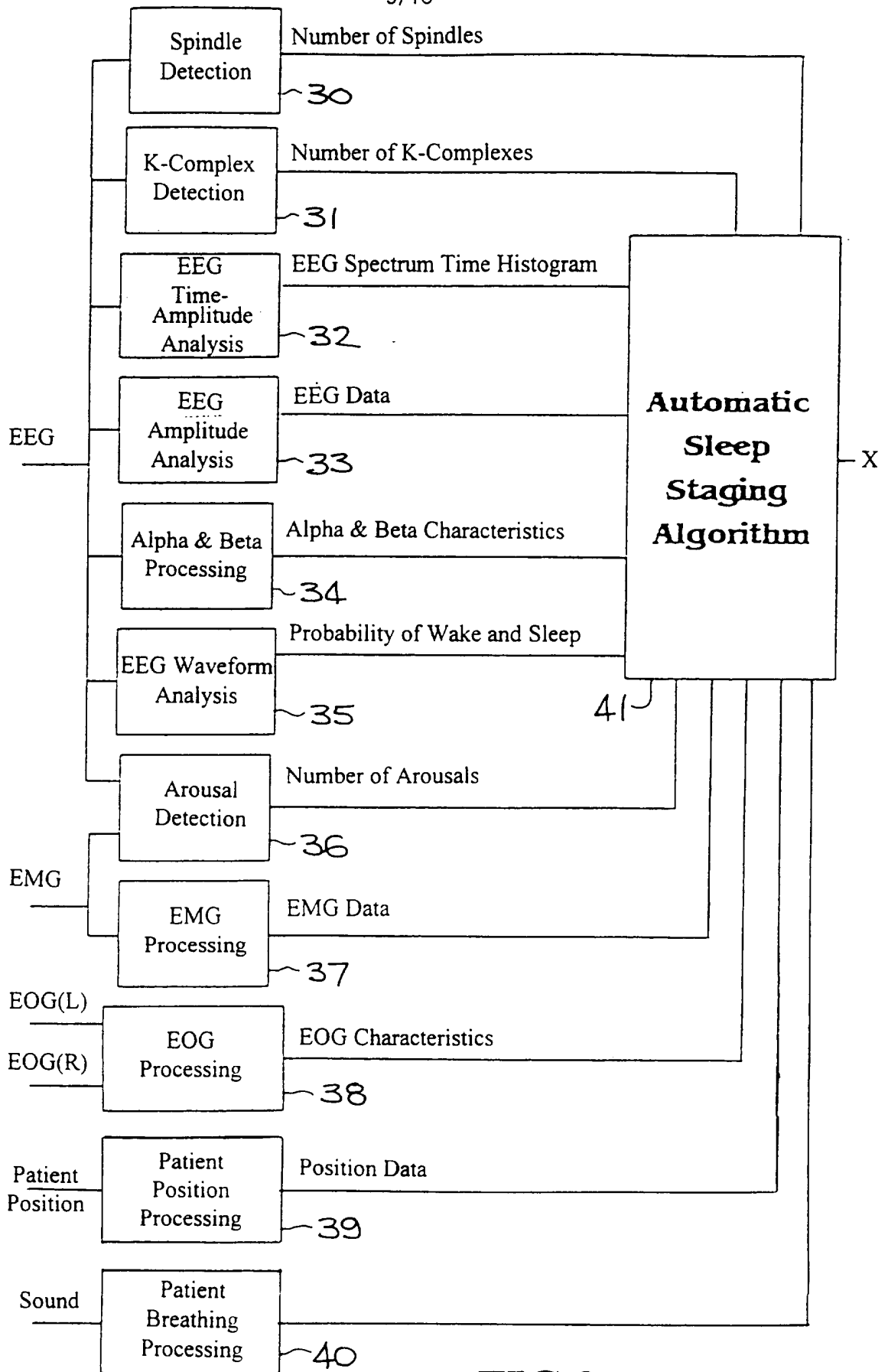
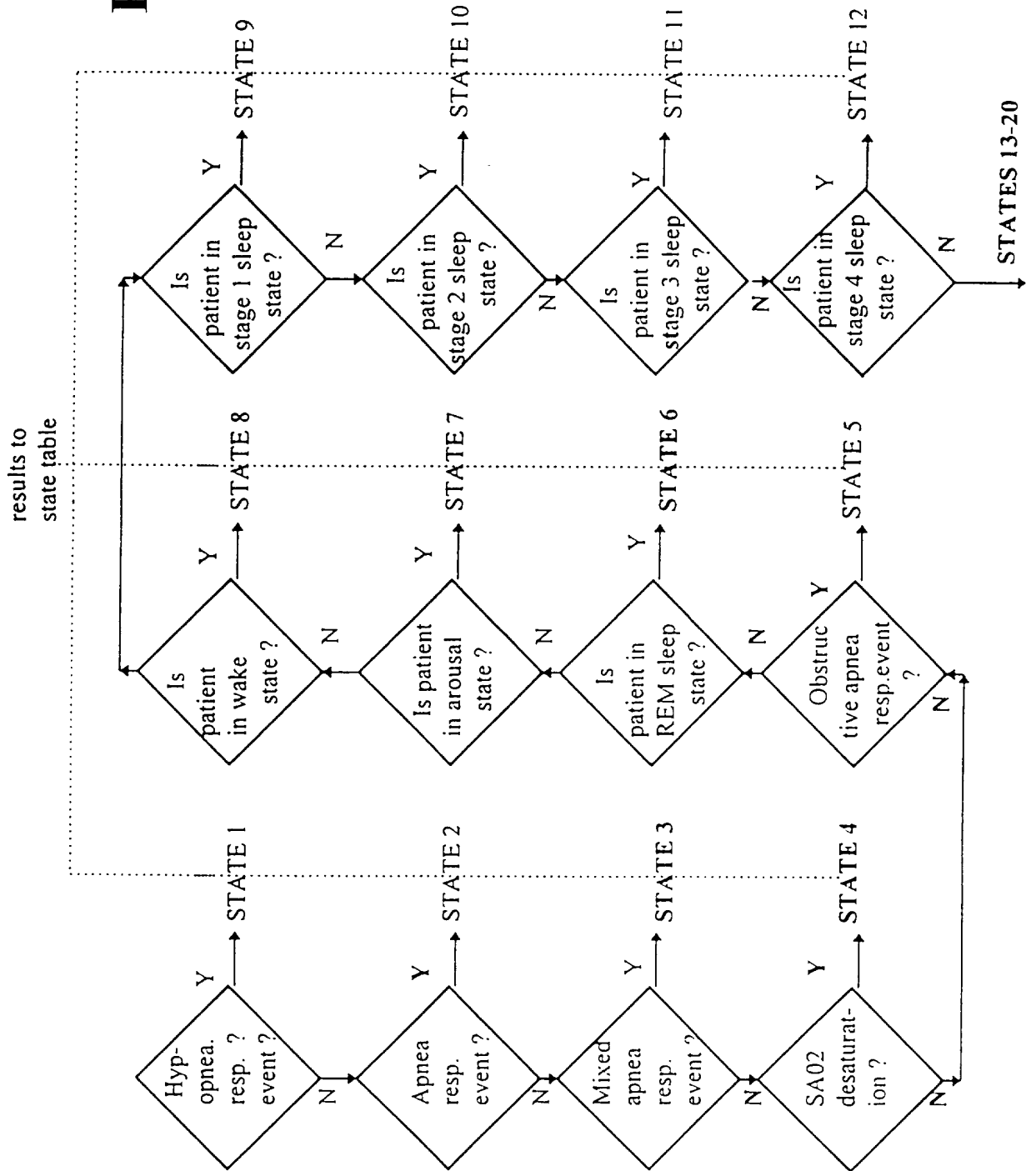

FIG 3a

FIG 3b



results to state table

state #	state	epoch n	epoch n+1	epoch n+2	epoch n+3	epoch n+4	epoch n+5	epoch n+6	epoch n+7	epoch n+8	epoch n+9	epoch n+10
S1	hyp	Y	N	N	Y	N	N	N	N	N	N	N
S2	apn	N	N	N	N	N	N	N	N	N	N	N
S3	3.mix	N	N	Y	N	N	N	N	N	N	N	N
S4	4.SA02	Y	N	N	N	N	N	N	N	N	N	N
S5	Obs	N	N	N	N	N	N	N	N	N	N	N
S6	REM	N	N	N	N	N	N	N	N	N	N	N
S7	arous	Y	N	N	Y	Y	Y	N	N	N	N	N
S8	wake	Y	Y	Y	Y	Y	Y	N	N	N	N	N
S9	stg 1	N	N	N	N	N	N	Y	Y	Y	Y	Y
S10	stg 2	N	N	N	N	N	N	N	N	N	N	N
S11	stg 3	N	N	N	N	N	N	N	N	N	N	N
S12	stg 4	N	N	N	N	N	N	N	N	N	N	N
S13	snore 0-low											
S14	snore 1 med											
S15	snore 2 high											
S16	snore 3 v high											
S17	heart rate 0-normal											
S18	heart rate 1-high											
S19	heart rate 2-low											
S20	heart rate 3-arryth.											

FIG 4

FIG 5a

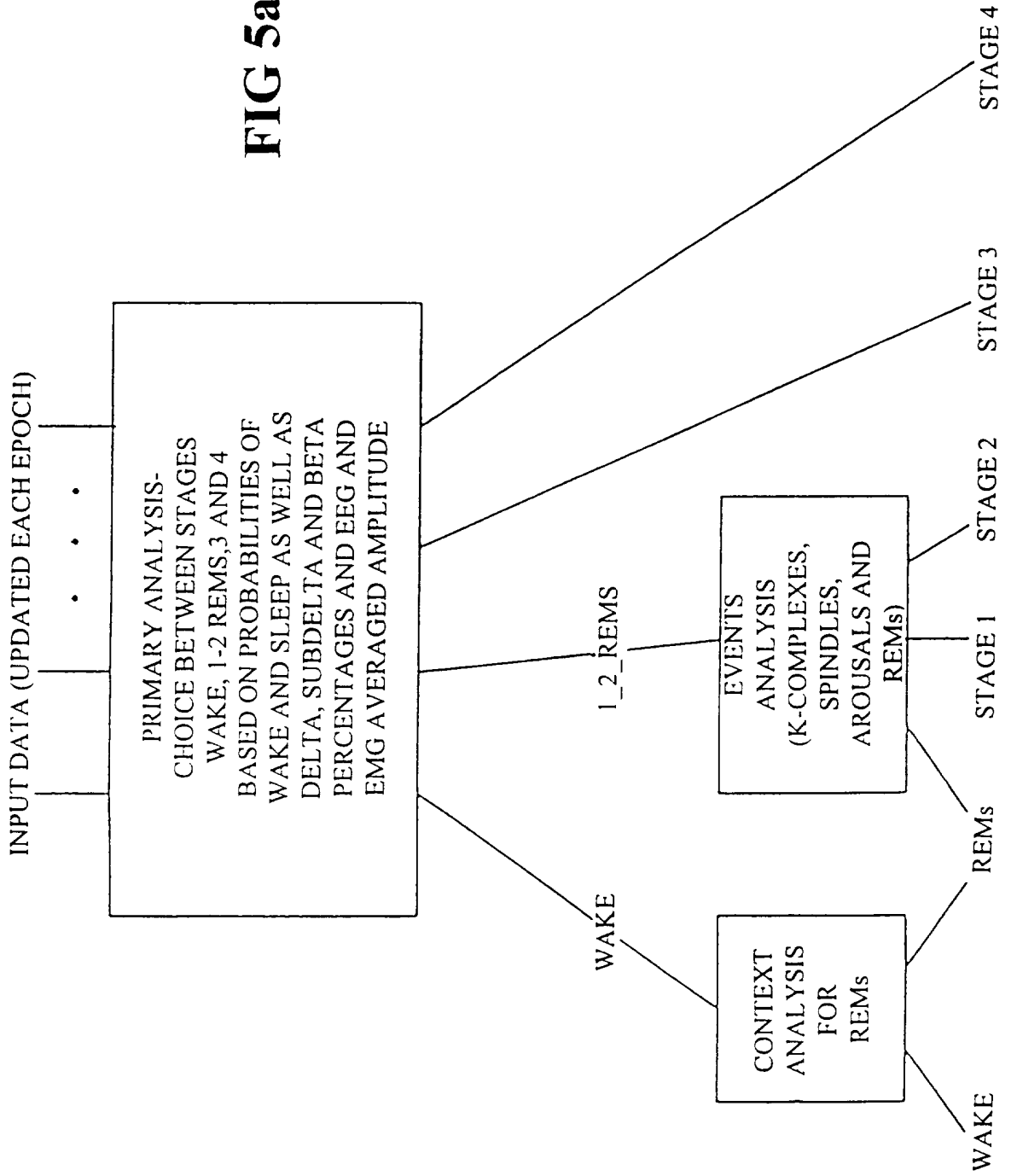

7/18

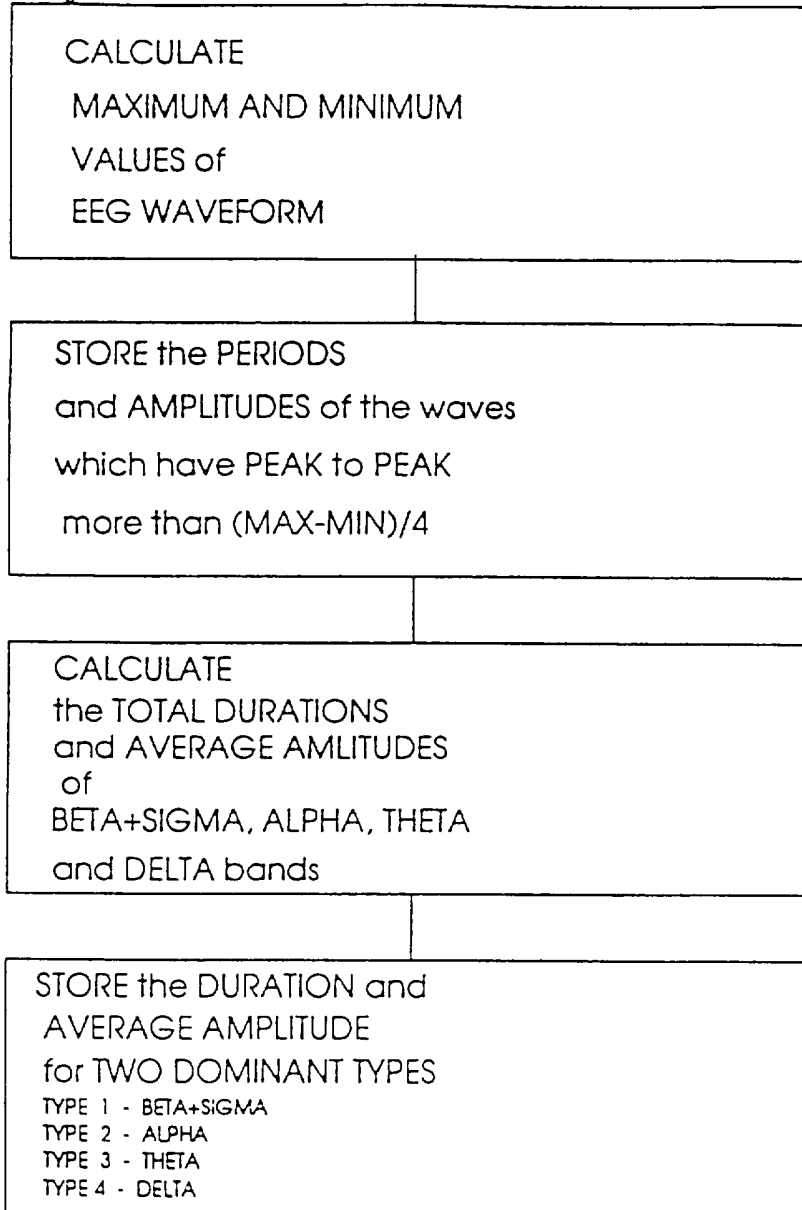
1. after each 1 sec:*2. after each epoch (20/30 sec):*

COMMON ANALYSIS of 1 sec DATA:

- a. detection of points where an EEG waveform type changes - the two dominant bands change
- b. calculation of SLEEP and WAKE probabilities:
 - Prob{WAKE} = the total duration of alpha when it is one of dominant types;
 - Prob{SLEEP} = the total duration of theta when it is one of dominant types+
the total duration of delta when it is one of dominant types;

FIG 5b

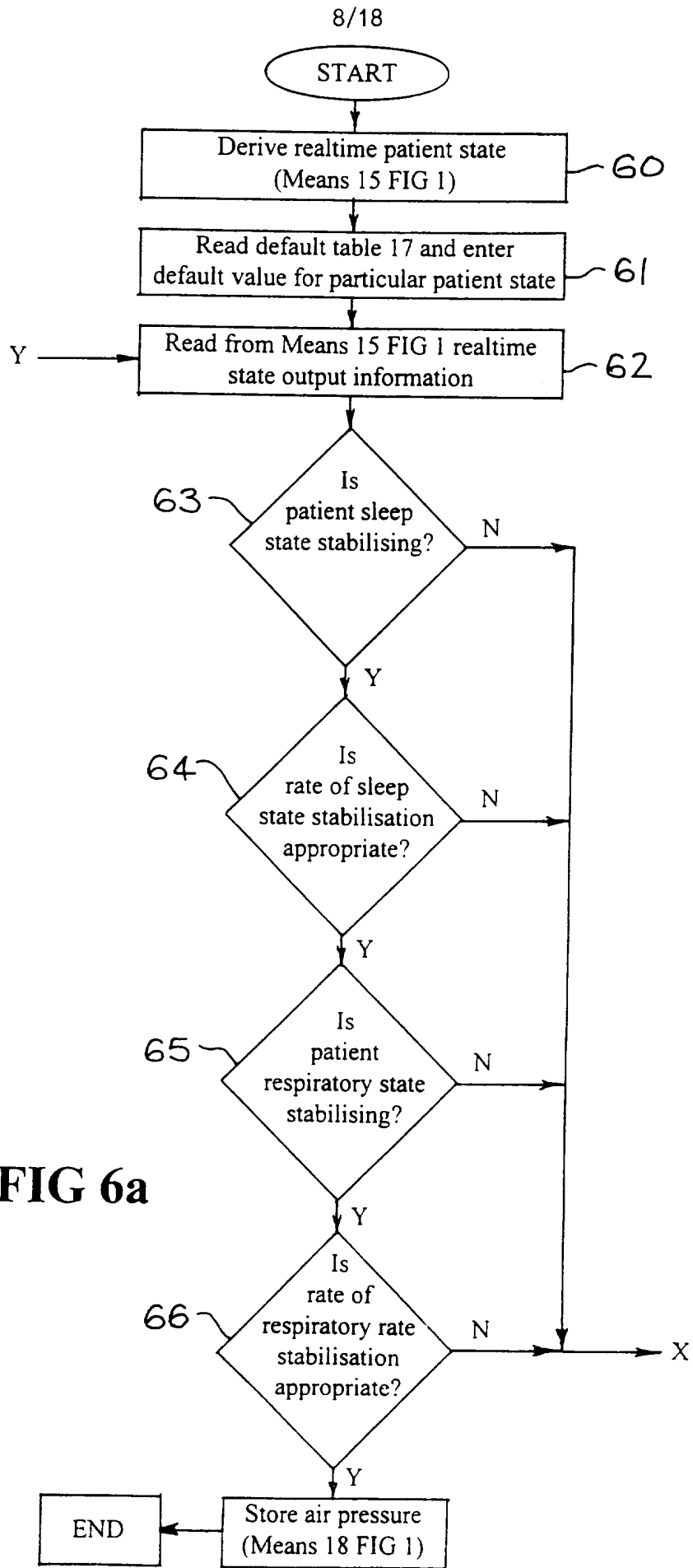

FIG 6a

9/18

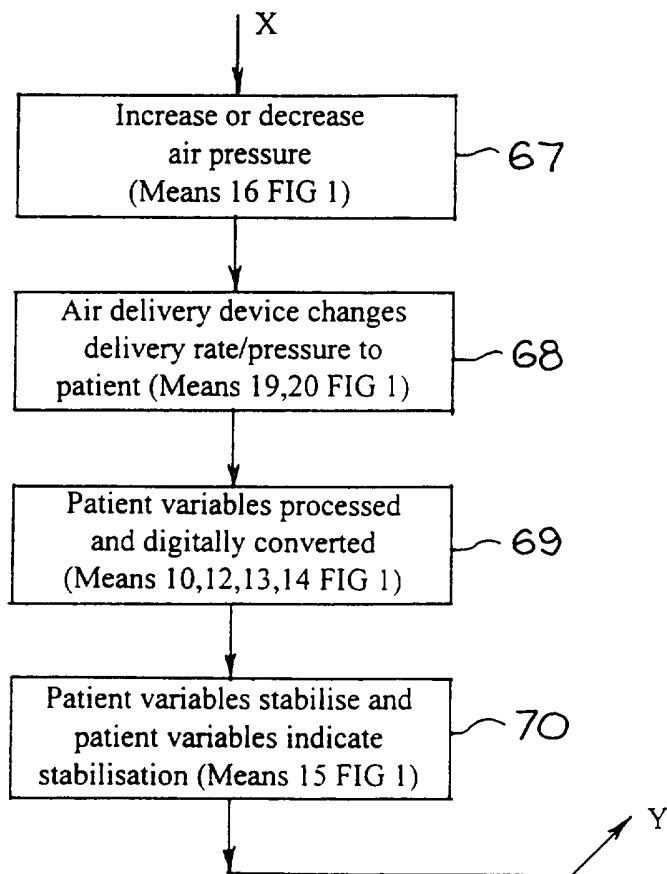

FIG 6b

FIG 8

KEY FOR MODE TABLE BELOW:
 MINIMUM CONFIGURATION
 NOT APPLICABLE

INPUT VARIABLE TYPE	DIAGNOSTIC MODE NUMBERS (PER KEY ON PAGES 15-16) AND MINIMUM INPUT VARIABLE CONFIGURATIONS FOR EACH MODE.															
	-WAKE-				-SLEEP-				AROUSAL-				RESPIRATORY----			
	1	1	1	1	2	2	2	2	3	3	3	3	4	4	4	4
EEG	<input checked="" type="checkbox"/>	<input checked="" type="checkbox"/>	<input checked="" type="checkbox"/>	<input checked="" type="checkbox"/>	<input checked="" type="checkbox"/>	<input checked="" type="checkbox"/>	<input checked="" type="checkbox"/>	<input checked="" type="checkbox"/>	<input checked="" type="checkbox"/>	<input checked="" type="checkbox"/>	<input checked="" type="checkbox"/>	<input checked="" type="checkbox"/>	<input checked="" type="checkbox"/>	<input checked="" type="checkbox"/>	<input checked="" type="checkbox"/>	<input checked="" type="checkbox"/>
ECG	<input checked="" type="checkbox"/>	<input checked="" type="checkbox"/>	<input checked="" type="checkbox"/>	<input checked="" type="checkbox"/>	<input checked="" type="checkbox"/>	<input checked="" type="checkbox"/>	<input checked="" type="checkbox"/>	<input checked="" type="checkbox"/>	<input checked="" type="checkbox"/>	<input checked="" type="checkbox"/>	<input checked="" type="checkbox"/>	<input checked="" type="checkbox"/>	<input checked="" type="checkbox"/>	<input checked="" type="checkbox"/>	<input checked="" type="checkbox"/>	<input checked="" type="checkbox"/>
EOG- LEFT AND/OR RIGHT EYE	<input checked="" type="checkbox"/>	<input checked="" type="checkbox"/>	<input checked="" type="checkbox"/>	<input checked="" type="checkbox"/>	<input checked="" type="checkbox"/>	<input checked="" type="checkbox"/>	<input checked="" type="checkbox"/>	<input checked="" type="checkbox"/>	<input checked="" type="checkbox"/>	<input checked="" type="checkbox"/>	<input checked="" type="checkbox"/>	<input checked="" type="checkbox"/>	<input checked="" type="checkbox"/>	<input checked="" type="checkbox"/>	<input checked="" type="checkbox"/>	<input checked="" type="checkbox"/>
EMG-SUBMENTAL	<input checked="" type="checkbox"/>	<input checked="" type="checkbox"/>	<input checked="" type="checkbox"/>	<input checked="" type="checkbox"/>	<input checked="" type="checkbox"/>	<input checked="" type="checkbox"/>	<input checked="" type="checkbox"/>	<input checked="" type="checkbox"/>	<input checked="" type="checkbox"/>	<input checked="" type="checkbox"/>	<input checked="" type="checkbox"/>	<input checked="" type="checkbox"/>	<input checked="" type="checkbox"/>	<input checked="" type="checkbox"/>	<input checked="" type="checkbox"/>	<input checked="" type="checkbox"/>
EMG-DIAPHRAGM	<input checked="" type="checkbox"/>	<input checked="" type="checkbox"/>	<input checked="" type="checkbox"/>	<input checked="" type="checkbox"/>	<input checked="" type="checkbox"/>	<input checked="" type="checkbox"/>	<input checked="" type="checkbox"/>	<input checked="" type="checkbox"/>	<input checked="" type="checkbox"/>	<input checked="" type="checkbox"/>	<input checked="" type="checkbox"/>	<input checked="" type="checkbox"/>	<input checked="" type="checkbox"/>	<input checked="" type="checkbox"/>	<input checked="" type="checkbox"/>	<input checked="" type="checkbox"/>
EMG-LEG MOVEMENT	<input checked="" type="checkbox"/>	<input checked="" type="checkbox"/>	<input checked="" type="checkbox"/>	<input checked="" type="checkbox"/>	<input checked="" type="checkbox"/>	<input checked="" type="checkbox"/>	<input checked="" type="checkbox"/>	<input checked="" type="checkbox"/>	<input checked="" type="checkbox"/>	<input checked="" type="checkbox"/>	<input checked="" type="checkbox"/>	<input checked="" type="checkbox"/>	<input checked="" type="checkbox"/>	<input checked="" type="checkbox"/>	<input checked="" type="checkbox"/>	<input checked="" type="checkbox"/>
LEG SENSOR- PIEZO	<input checked="" type="checkbox"/>	<input checked="" type="checkbox"/>	<input checked="" type="checkbox"/>	<input checked="" type="checkbox"/>	<input checked="" type="checkbox"/>	<input checked="" type="checkbox"/>	<input checked="" type="checkbox"/>	<input checked="" type="checkbox"/>	<input checked="" type="checkbox"/>	<input checked="" type="checkbox"/>	<input checked="" type="checkbox"/>	<input checked="" type="checkbox"/>	<input checked="" type="checkbox"/>	<input checked="" type="checkbox"/>	<input checked="" type="checkbox"/>	<input checked="" type="checkbox"/>
OXIMETRY	<input checked="" type="checkbox"/>	<input checked="" type="checkbox"/>	<input checked="" type="checkbox"/>	<input checked="" type="checkbox"/>	<input checked="" type="checkbox"/>	<input checked="" type="checkbox"/>	<input checked="" type="checkbox"/>	<input checked="" type="checkbox"/>	<input checked="" type="checkbox"/>	<input checked="" type="checkbox"/>	<input checked="" type="checkbox"/>	<input checked="" type="checkbox"/>	<input checked="" type="checkbox"/>	<input checked="" type="checkbox"/>	<input checked="" type="checkbox"/>	<input checked="" type="checkbox"/>
CO2	<input checked="" type="checkbox"/>	<input checked="" type="checkbox"/>	<input checked="" type="checkbox"/>	<input checked="" type="checkbox"/>	<input checked="" type="checkbox"/>	<input checked="" type="checkbox"/>	<input checked="" type="checkbox"/>	<input checked="" type="checkbox"/>	<input checked="" type="checkbox"/>	<input checked="" type="checkbox"/>	<input checked="" type="checkbox"/>	<input checked="" type="checkbox"/>	<input checked="" type="checkbox"/>	<input checked="" type="checkbox"/>	<input checked="" type="checkbox"/>	<input checked="" type="checkbox"/>
RESPIRATORY EFFORT ABDOMINAL	<input checked="" type="checkbox"/>	<input checked="" type="checkbox"/>	<input checked="" type="checkbox"/>	<input checked="" type="checkbox"/>	<input checked="" type="checkbox"/>	<input checked="" type="checkbox"/>	<input checked="" type="checkbox"/>	<input checked="" type="checkbox"/>	<input checked="" type="checkbox"/>	<input checked="" type="checkbox"/>	<input checked="" type="checkbox"/>	<input checked="" type="checkbox"/>	<input checked="" type="checkbox"/>	<input checked="" type="checkbox"/>	<input checked="" type="checkbox"/>	<input checked="" type="checkbox"/>
RESPIRATORY EFFORT THORACIC	<input checked="" type="checkbox"/>	<input checked="" type="checkbox"/>	<input checked="" type="checkbox"/>	<input checked="" type="checkbox"/>	<input checked="" type="checkbox"/>	<input checked="" type="checkbox"/>	<input checked="" type="checkbox"/>	<input checked="" type="checkbox"/>	<input checked="" type="checkbox"/>	<input checked="" type="checkbox"/>	<input checked="" type="checkbox"/>	<input checked="" type="checkbox"/>	<input checked="" type="checkbox"/>	<input checked="" type="checkbox"/>	<input checked="" type="checkbox"/>	<input checked="" type="checkbox"/>
AIRFLOW	<input checked="" type="checkbox"/>	<input checked="" type="checkbox"/>	<input checked="" type="checkbox"/>	<input checked="" type="checkbox"/>	<input checked="" type="checkbox"/>	<input checked="" type="checkbox"/>	<input checked="" type="checkbox"/>	<input checked="" type="checkbox"/>	<input checked="" type="checkbox"/>	<input checked="" type="checkbox"/>	<input checked="" type="checkbox"/>	<input checked="" type="checkbox"/>	<input checked="" type="checkbox"/>	<input checked="" type="checkbox"/>	<input checked="" type="checkbox"/>	<input checked="" type="checkbox"/>
CPAP PRESSURE	<input checked="" type="checkbox"/>	<input checked="" type="checkbox"/>	<input checked="" type="checkbox"/>	<input checked="" type="checkbox"/>	<input checked="" type="checkbox"/>	<input checked="" type="checkbox"/>	<input checked="" type="checkbox"/>	<input checked="" type="checkbox"/>	<input checked="" type="checkbox"/>	<input checked="" type="checkbox"/>	<input checked="" type="checkbox"/>	<input checked="" type="checkbox"/>	<input checked="" type="checkbox"/>	<input checked="" type="checkbox"/>	<input checked="" type="checkbox"/>	<input checked="" type="checkbox"/>
SOUND	<input checked="" type="checkbox"/>	<input checked="" type="checkbox"/>	<input checked="" type="checkbox"/>	<input checked="" type="checkbox"/>	<input checked="" type="checkbox"/>	<input checked="" type="checkbox"/>	<input checked="" type="checkbox"/>	<input checked="" type="checkbox"/>	<input checked="" type="checkbox"/>	<input checked="" type="checkbox"/>	<input checked="" type="checkbox"/>	<input checked="" type="checkbox"/>	<input checked="" type="checkbox"/>	<input checked="" type="checkbox"/>	<input checked="" type="checkbox"/>	<input checked="" type="checkbox"/>
LIGHT STATUS	<input checked="" type="checkbox"/>	<input checked="" type="checkbox"/>	<input checked="" type="checkbox"/>	<input checked="" type="checkbox"/>	<input checked="" type="checkbox"/>	<input checked="" type="checkbox"/>	<input checked="" type="checkbox"/>	<input checked="" type="checkbox"/>	<input checked="" type="checkbox"/>	<input checked="" type="checkbox"/>	<input checked="" type="checkbox"/>	<input checked="" type="checkbox"/>	<input checked="" type="checkbox"/>	<input checked="" type="checkbox"/>	<input checked="" type="checkbox"/>	<input checked="" type="checkbox"/>
SUBJECT'S POSITION STATUS	<input checked="" type="checkbox"/>	<input checked="" type="checkbox"/>	<input checked="" type="checkbox"/>	<input checked="" type="checkbox"/>	<input checked="" type="checkbox"/>	<input checked="" type="checkbox"/>	<input checked="" type="checkbox"/>	<input checked="" type="checkbox"/>	<input checked="" type="checkbox"/>	<input checked="" type="checkbox"/>	<input checked="" type="checkbox"/>	<input checked="" type="checkbox"/>	<input checked="" type="checkbox"/>	<input checked="" type="checkbox"/>	<input checked="" type="checkbox"/>	<input checked="" type="checkbox"/>
SUBJECT VIDEO IMAGE- SUBJECTS EYES OPEN/CLOSE	<input checked="" type="checkbox"/>	<input checked="" type="checkbox"/>	<input checked="" type="checkbox"/>	<input checked="" type="checkbox"/>	<input checked="" type="checkbox"/>	<input checked="" type="checkbox"/>	<input checked="" type="checkbox"/>	<input checked="" type="checkbox"/>	<input checked="" type="checkbox"/>	<input checked="" type="checkbox"/>	<input checked="" type="checkbox"/>	<input checked="" type="checkbox"/>	<input checked="" type="checkbox"/>	<input checked="" type="checkbox"/>	<input checked="" type="checkbox"/>	<input checked="" type="checkbox"/>
SUBJECT VIDEO IMAGE- EYE LID ACTIVITY	<input checked="" type="checkbox"/>	<input checked="" type="checkbox"/>	<input checked="" type="checkbox"/>	<input checked="" type="checkbox"/>	<input checked="" type="checkbox"/>	<input checked="" type="checkbox"/>	<input checked="" type="checkbox"/>	<input checked="" type="checkbox"/>	<input checked="" type="checkbox"/>	<input checked="" type="checkbox"/>	<input checked="" type="checkbox"/>	<input checked="" type="checkbox"/>	<input checked="" type="checkbox"/>	<input checked="" type="checkbox"/>	<input checked="" type="checkbox"/>	<input checked="" type="checkbox"/>
TIME AND DATE STAMPING OF VIDEO IMAGE	<input checked="" type="checkbox"/>	<input checked="" type="checkbox"/>	<input checked="" type="checkbox"/>	<input checked="" type="checkbox"/>	<input checked="" type="checkbox"/>	<input checked="" type="checkbox"/>	<input checked="" type="checkbox"/>	<input checked="" type="checkbox"/>	<input checked="" type="checkbox"/>	<input checked="" type="checkbox"/>	<input checked="" type="checkbox"/>	<input checked="" type="checkbox"/>	<input checked="" type="checkbox"/>	<input checked="" type="checkbox"/>	<input checked="" type="checkbox"/>	<input checked="" type="checkbox"/>
COMPLEX SOUND ANALYSIS	<input checked="" type="checkbox"/>	<input checked="" type="checkbox"/>	<input checked="" type="checkbox"/>	<input checked="" type="checkbox"/>	<input checked="" type="checkbox"/>	<input checked="" type="checkbox"/>	<input checked="" type="checkbox"/>	<input checked="" type="checkbox"/>	<input checked="" type="checkbox"/>	<input checked="" type="checkbox"/>	<input checked="" type="checkbox"/>	<input checked="" type="checkbox"/>	<input checked="" type="checkbox"/>	<input checked="" type="checkbox"/>	<input checked="" type="checkbox"/>	<input checked="" type="checkbox"/>
PHYSIOLOGICAL EVENTS- ARRHYTHMIA, EEG SPIKE DETECTION, EEG SPINDLES	<input checked="" type="checkbox"/>	<input checked="" type="checkbox"/>	<input checked="" type="checkbox"/>	<input checked="" type="checkbox"/>	<input checked="" type="checkbox"/>	<input checked="" type="checkbox"/>	<input checked="" type="checkbox"/>	<input checked="" type="checkbox"/>	<input checked="" type="checkbox"/>	<input checked="" type="checkbox"/>	<input checked="" type="checkbox"/>	<input checked="" type="checkbox"/>	<input checked="" type="checkbox"/>	<input checked="" type="checkbox"/>	<input checked="" type="checkbox"/>	<input checked="" type="checkbox"/>
ENDOSCOPY	<input checked="" type="checkbox"/>	<input checked="" type="checkbox"/>	<input checked="" type="checkbox"/>	<input checked="" type="checkbox"/>	<input checked="" type="checkbox"/>	<input checked="" type="checkbox"/>	<input checked="" type="checkbox"/>	<input checked="" type="checkbox"/>	<input checked="" type="checkbox"/>	<input checked="" type="checkbox"/>	<input checked="" type="checkbox"/>	<input checked="" type="checkbox"/>	<input checked="" type="checkbox"/>	<input checked="" type="checkbox"/>	<input checked="" type="checkbox"/>	<input checked="" type="checkbox"/>
BREATHE BY BREATHE ANALYSIS- PNEUMOTACHOGRAPH	<input checked="" type="checkbox"/>	<input checked="" type="checkbox"/>	<input checked="" type="checkbox"/>	<input checked="" type="checkbox"/>	<input checked="" type="checkbox"/>	<input checked="" type="checkbox"/>	<input checked="" type="checkbox"/>	<input checked="" type="checkbox"/>	<input checked="" type="checkbox"/>	<input checked="" type="checkbox"/>	<input checked="" type="checkbox"/>	<input checked="" type="checkbox"/>	<input checked="" type="checkbox"/>	<input checked="" type="checkbox"/>	<input checked="" type="checkbox"/>	<input checked="" type="checkbox"/>
3 D IMAGING	<input checked="" type="checkbox"/>	<input checked="" type="checkbox"/>	<input checked="" type="checkbox"/>	<input checked="" type="checkbox"/>	<input checked="" type="checkbox"/>	<input checked="" type="checkbox"/>	<input checked="" type="checkbox"/>	<input checked="" type="checkbox"/>	<input checked="" type="checkbox"/>	<input checked="" type="checkbox"/>	<input checked="" type="checkbox"/>	<input checked="" type="checkbox"/>	<input checked="" type="checkbox"/>	<input checked="" type="checkbox"/>	<input checked="" type="checkbox"/>	<input checked="" type="checkbox"/>
INFRA-RED EYE MOVEMENT AND DETECTION	<input checked="" type="checkbox"/>	<input checked="" type="checkbox"/>	<input checked="" type="checkbox"/>	<input checked="" type="checkbox"/>	<input checked="" type="checkbox"/>	<input checked="" type="checkbox"/>	<input checked="" type="checkbox"/>	<input checked="" type="checkbox"/>	<input checked="" type="checkbox"/>	<input checked="" type="checkbox"/>	<input checked="" type="checkbox"/>	<input checked="" type="checkbox"/>	<input checked="" type="checkbox"/>	<input checked="" type="checkbox"/>	<input checked="" type="checkbox"/>	<input checked="" type="checkbox"/>
EEG DELTA AND ALPHA WAVE DETECTION	<input checked="" type="checkbox"/>	<input checked="" type="checkbox"/>	<input checked="" type="checkbox"/>	<input checked="" type="checkbox"/>	<input checked="" type="checkbox"/>	<input checked="" type="checkbox"/>	<input checked="" type="checkbox"/>	<input checked="" type="checkbox"/>	<input checked="" type="checkbox"/>	<input checked="" type="checkbox"/>	<input checked="" type="checkbox"/>	<input checked="" type="checkbox"/>	<input checked="" type="checkbox"/>	<input checked="" type="checkbox"/>	<input checked="" type="checkbox"/>	<input checked="" type="checkbox"/>
DELTA WAVE DETECTIONS	<input checked="" type="checkbox"/>	<input checked="" type="checkbox"/>	<input checked="" type="checkbox"/>	<input checked="" type="checkbox"/>	<input checked="" type="checkbox"/>	<input checked="" type="checkbox"/>	<input checked="" type="checkbox"/>	<input checked="" type="checkbox"/>	<input checked="" type="checkbox"/>	<input checked="" type="checkbox"/>	<input checked="" type="checkbox"/>	<input checked="" type="checkbox"/>	<input checked="" type="checkbox"/>	<input checked="" type="checkbox"/>	<input checked="" type="checkbox"/>	<input checked="" type="checkbox"/>
MATRESS DEVICE (PVDF OR SC5B)	<input checked="" type="checkbox"/>	<input checked="" type="checkbox"/>	<input checked="" type="checkbox"/>	<input checked="" type="checkbox"/>	<input checked="" type="checkbox"/>	<input checked="" type="checkbox"/>	<input checked="" type="checkbox"/>	<input checked="" type="checkbox"/>	<input checked="" type="checkbox"/>	<input checked="" type="checkbox"/>	<input checked="" type="checkbox"/>	<input checked="" type="checkbox"/>	<input checked="" type="checkbox"/>	<input checked="" type="checkbox"/>	<input checked="" type="checkbox"/>	<input checked="" type="checkbox"/>

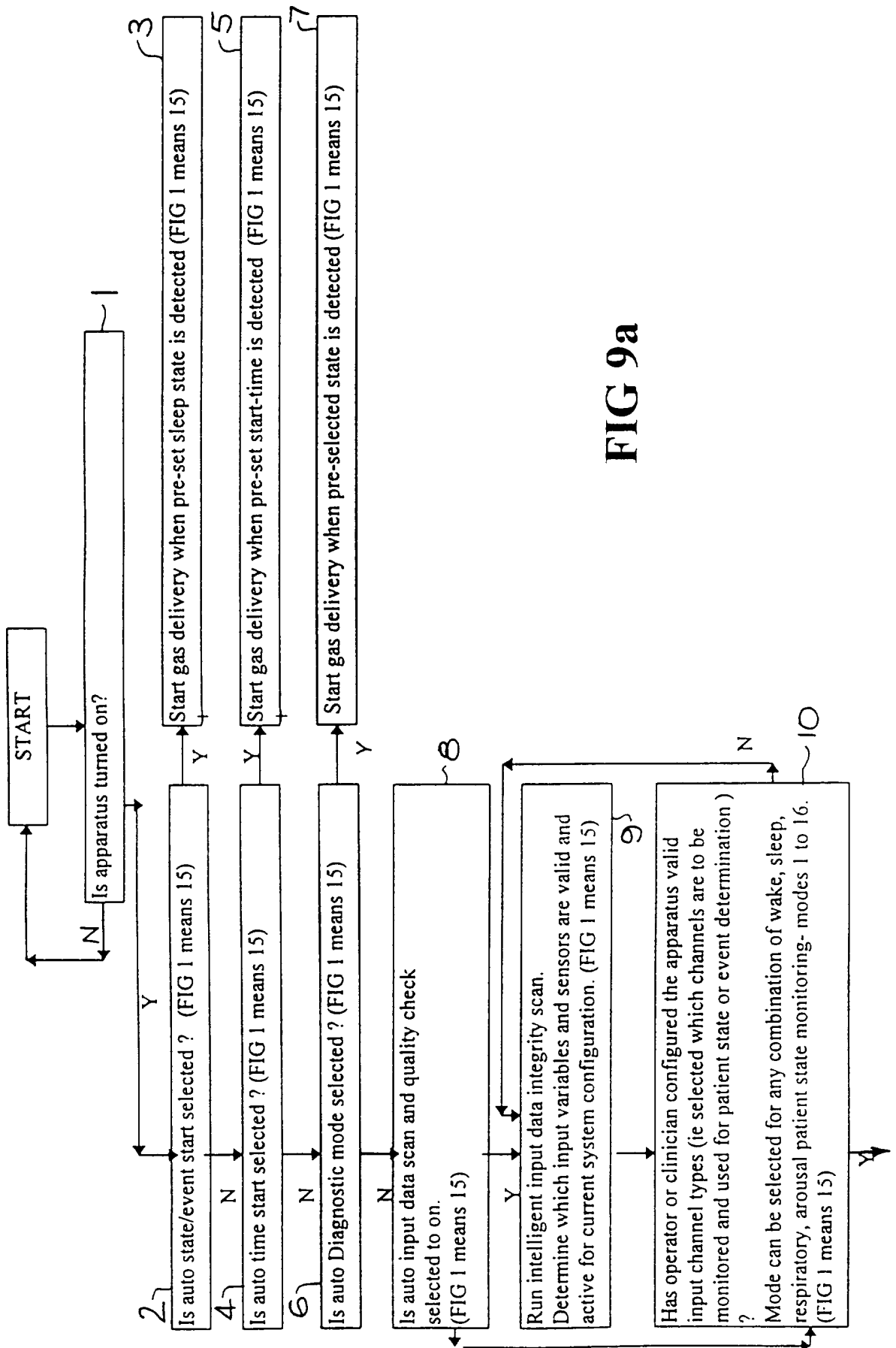

FIG 9a

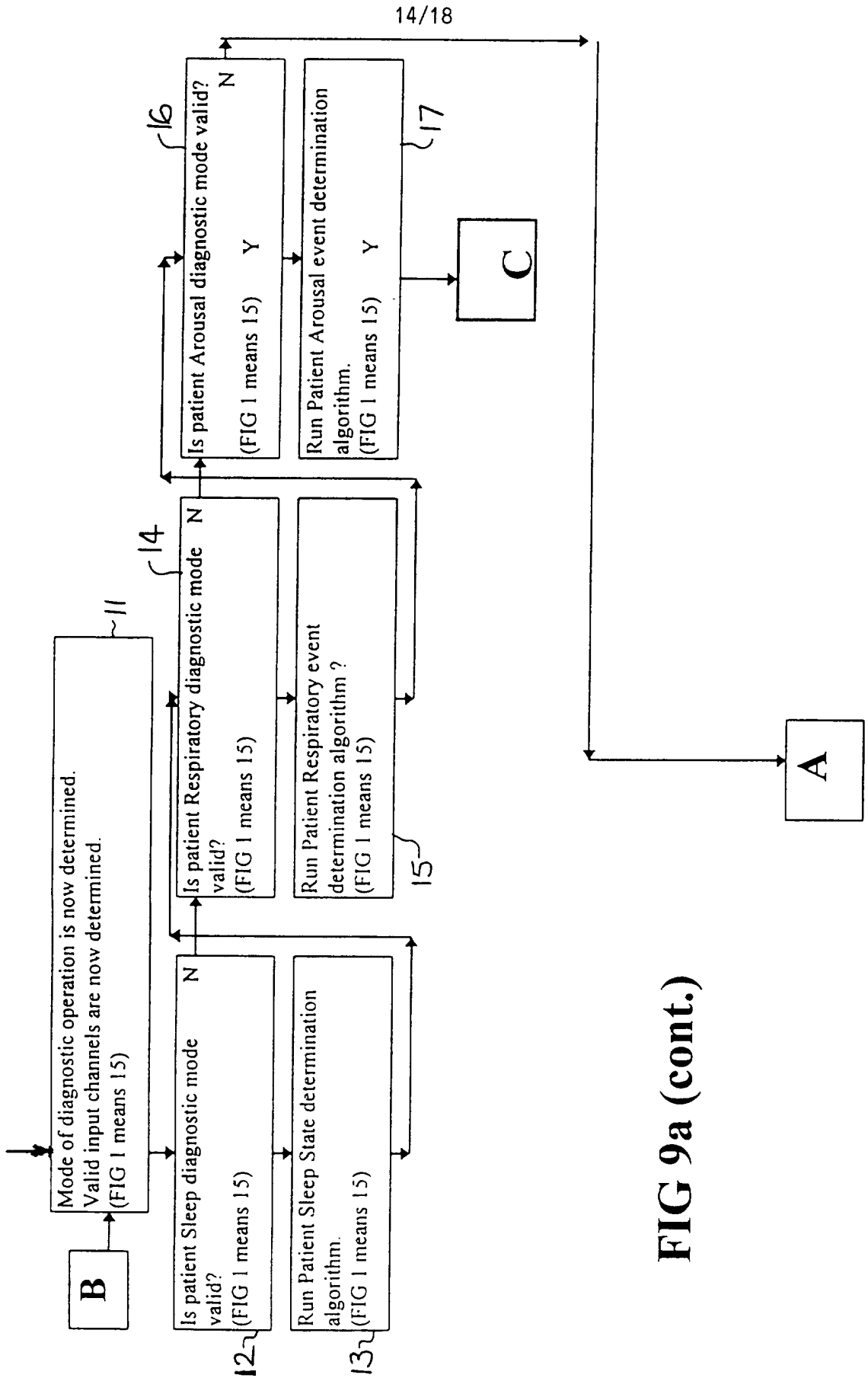
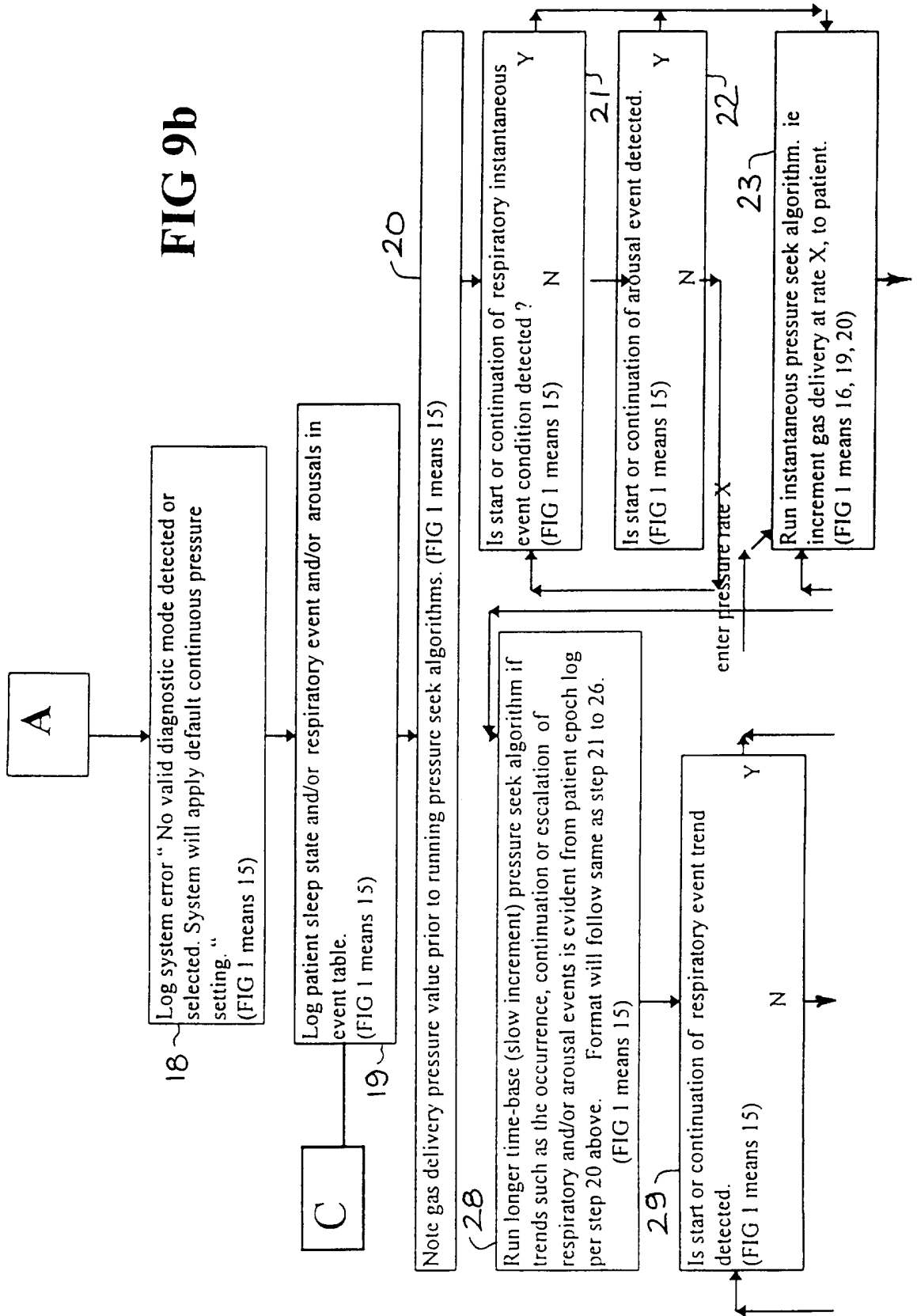

FIG 9a (cont.)

FIG 9b



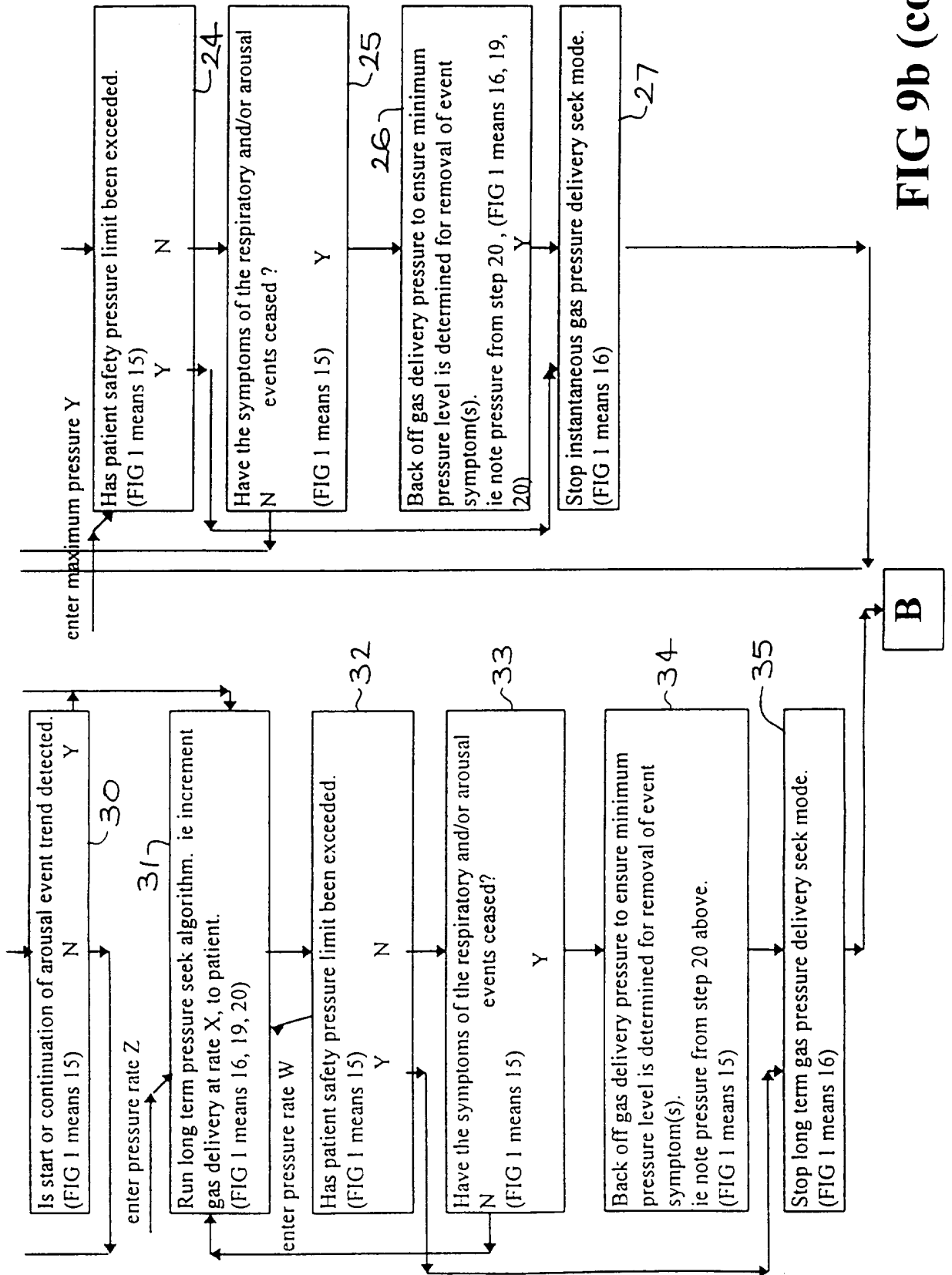

FIG 9b (cont.)

	EPOCHS NUMBERS								
States & events	1	2	3	4	5	6	7	8	9
Sleep state	Wake	Wake	Wake	Wake	Wake	Wake	Wake	Wake	Wake
Respiratory events	None	None	None	None	None	None	None	None	None
Arousal event	3	2	1	2	3	5	4	2	0
Patient position	S	S	S	S	S	S	S	S	S

FIG 10

18/18

SITES & EVENTS	epoch numbers																		
	1	2	3	4	5	6	7	8	9	10	11	12	13	14	15	16	17	18	
Sleep state	W	W	W	W	W	W	W	W	1	1	1	1	2	2	2	2	2	2	
Respiratory event type	-	-	-	-	-	-	-	-	-	-	-	O	C	O	-	-	-	-	
Arousal event and type	-	-	-	-	-	-	-	-	-	-	-	A	A	A	A	-	-	-	-
Patient position	S	S	S	S	S	S	S	B	B	B	B	B	L	L	L	L	L	L	L
Is patient state stable ? Y/N	Y	Y	Y	Y	Y	Y	Y	Y	Y	Y	Y	N	N	N	Y	Y	Y	Y	Y
Nominal pressure value-CMH20	8	8	8	8	8	8	8	8	8	8	8	9	9.5	10	10	10	10	10	10

TABLE KEY

- PATIENT LEFT POSITION L
- PATIENT RIGHT POSITION R
- PATIENT FRONT POSITION F
- PATIENT BACK POSITION B
- PATIENT SITTING POSITION S
- STAGE 1 SLEEP 1
- STAGE 2 SLEEP 2
- STAGE 3 SLEEP 3
- STAGE 4 SLEEP 4
- STAGE REM SLEEP R
- STAGE MOVEMENT TIME M
- AROUSAL A
- OBSTRUCTIVE SLEEP APNEA O
- MIXED APNEA M
- CENTRAL APNEA C

FIG 11

INTERNATIONAL SEARCH REPORT

International Application No.
PCT/AU 96/00679**A. CLASSIFICATION OF SUBJECT MATTER**Int Cl⁶: A61M 16/00

According to International Patent Classification (IPC) or to both national classification and IPC

B. FIELDS SEARCHEDMinimum documentation searched (classification system followed by classification symbols)
IPC A61M 16/00, post 1980Documentation searched other than minimum documentation to the extent that such documents are included in the fields searched
AU IPC as above

Electronic data base consulted during the international search (name of data base and, where practicable, search terms used)

C. DOCUMENTS CONSIDERED TO BE RELEVANT

Category*	Citation of document, with indication, where appropriate, of the relevant passages	Relevant to claim No.
X	WO 92/22244 A (AXE et al) 23 December 1992	1,3,8,10,12,14,16,22,24
X	AU 33877/93 (PRUITAN - BENNETT CORP) 22 April 1993	1,3,14,16,22
X	WO 88/10108 A (TRAVENOL CENTRE FOR MEDICAL RESEARCH) 29 December 1988	1,3,14,16,22



Further documents are listed in the continuation of Box C



See patent family annex

* Special categories of cited documents:

"A" document defining the general state of the art which is not considered to be of particular relevance

"E" earlier document but published on or after the international filing date

"L" document which may throw doubts on priority claim(s) or which is cited to establish the publication date of another citation or other special reason (as specified)

"O" document referring to an oral disclosure, use, exhibition or other means

"P" document published prior to the international filing date but later than the priority date claimed

"T"

later document published after the international filing date or priority date and not in conflict with the application but cited to understand the principle or theory underlying the invention

"X"

document of particular relevance; the claimed invention cannot be considered novel or cannot be considered to involve an inventive step when the document is taken alone

"Y"

document of particular relevance; the claimed invention cannot be considered to involve an inventive step when the document is combined with one or more other such documents, such combination being obvious to a person skilled in the art

"&"

document member of the same patent family

Date of the actual completion of the international search

16 January 1997

Date of mailing of the international search report

24 FEB 1997

Name and mailing address of the ISA/AU
AUSTRALIAN INDUSTRIAL PROPERTY ORGANISATION
PO BOX 200
WODEN ACT 2606
AUSTRALIA Facsimile No.: (06) 285 3929

Authorized officer

SUSAN T. PRING

Telephone No.: (06) 283 2190



INTERNATIONAL SEARCH REPORT

International Application No.

PCT/AU 96/00679

C (Continuation) DOCUMENTS CONSIDERED TO BE RELEVANT		
Category*	Citation of document, with indication, where appropriate, of the relevant passages	Relevant to claim No.
X	WO 94/23780 A (RESPIRONICS) 27 October 1994	1,3,8,16,22
X	AU 77641/94 A (RESCARE LTD) 18 May 1995	1,3,8,9,14-16, 22
X,P	WO 95/32016 (PURITAN - BENNETT CORP) 30 November 1995	1,3,10-16, e, 22,24,25
XP	AU 30678/95 A (RESPIRONICS, INC.) 16 November 1995	1,3,8,14,16,22
A,P	WO 95/33403 A (BADER) 14 December 1995	
A	WO 94/16610 A (UNIVERSITE DE RENNES) 4 August 1994	
A	WO 91/13575 (LEFFET & PLATT) 19 September 1991	

INTERNATIONAL SEARCH REPORT

International Application No.

Information on patent family members**PCT/AU 96/00679**

This Annex lists the known "A" publication level patent family members relating to the patent documents cited in the above-mentioned international search report. The Australian Patent Office is in no way liable for these particulars which are merely given for the purpose of information.

Patent Document Cited in Search Report		Patent Family Member					
WO	92/22244	AU	21892/92	CA	2111324	EP	592492
		US	5203343	US	5458137		
AU	33877/93	AU	59270/90	AU	48748/93	AU	34471/95
		EP	472664	WO	9014121	US	5134995
		US	5259373	US	5549106		
WO	94/23780	AU	66296/94	CA	2159336	EP	699085
		US	548137				
AU	77641/94	EP	651971				
WO	95/32016	AU	25895/95	US	5490502	US	5535739
		US	5546933				
AU	30678/95	AU	62221/90	AU	38508/93	CA	2924477
		EP	425092	FI	904566	JP	3222963
		US	5148802	US	5239995	US	5433193
		US	5313937				
WO	95/33403	SE	9401959				
WO	94/16610	EP	681447	FR	2700683		
WO	91/13575	AU	75696/91	CA	2077679	EP	528809
		US	5062169	ZA	9101451		

END OF ANNEX