

(No Model.)

F. F. BOURDIL.
LIQUID ATOMIZER AND PULVERIZER.

No. 465,013.

Patented Dec. 15, 1891.

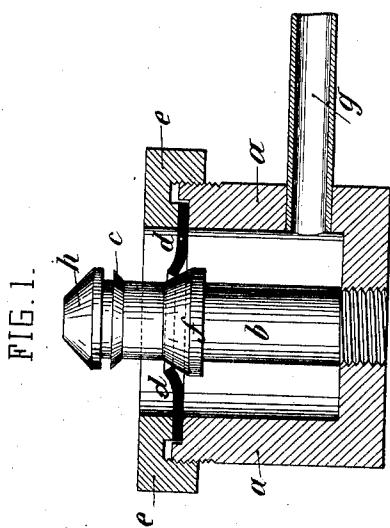
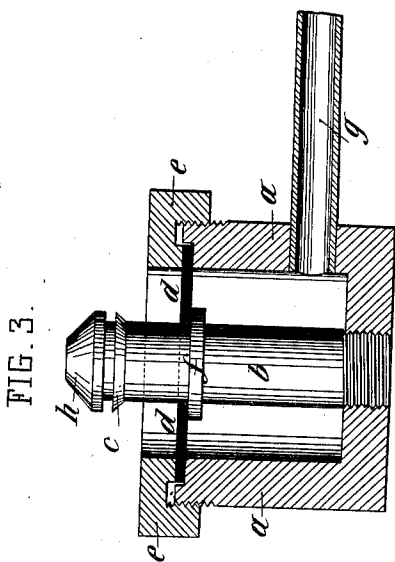
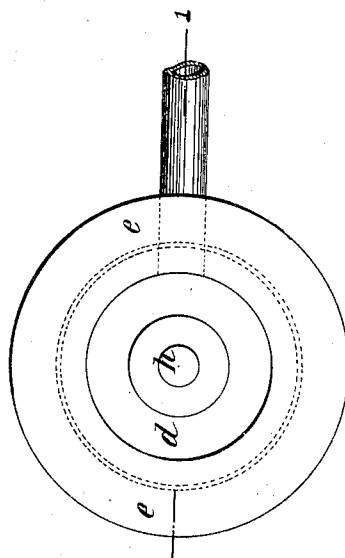

FIG. 2.



Witnessed
Henry E. Eording.
R. C. Mitchell.

Inventor
François Fernand Bourdil
by his Attorneys
Briesen & Knauth

UNITED STATES PATENT OFFICE.

FRANÇOIS FERNAND BOURDIL, OF PARIS, FRANCE.

LIQUID ATOMIZER OR PULVERIZER.

SPECIFICATION forming part of Letters Patent No. 465,013, dated December 15, 1891.

Application filed May 2, 1891. Serial No. 391,355. (No model.)

To all whom it may concern:

Be it known that I, FRANÇOIS FERNAND BOURDIL, of the city of Paris, France, have invented a Liquid Atomizer or Pulverizer, of which the following is a full, clear, and exact description.

This invention relates to apparatus for atomizing or pulverizing liquids; and it consists, essentially, in the combination of a flexible diaphragm having a central aperture, with a post or spindle passing through it having a shoulder, against which the liquid, divided into a thin stream by being forced between the post and diaphragm, is projected, and thereby becomes pulverized. This post is fixed into a box, of which the diaphragm forms the cover, to which the liquid is supplied under pressure.

Reference is to be had to the accompanying drawings, forming part of this specification, in which—

Figure 1 represents a side sectional elevation on line 1 1, Fig. 2, and Fig. 2 a plan, of the pulverizer. Fig. 3 represents a sectional elevation of a modification.

The same letters of reference denote like parts in all the figures.

The apparatus consists of a box *a*, in the center of which is fixed a post *b*, of cylindrical or other form, passing through a central aperture in a flexible diaphragm *d*, made of india-rubber or other elastic or flexible material, clamped between a seat in the upper edge of the box and a ring *e* screwing thereon. The inner edge of the diaphragm rests on a shoulder *f* upon the post *b*, which shoulder may either be coned for the purpose of slightly raising the said inner edge of the diaphragm *d*, as shown in Fig. 1, or be made flat, as in Fig. 3. The diaphragm acts as a valve, through which the liquid introduced under pressure by pipe *g* is expelled in the form of a film along the upper part of the post. The latter is provided with an abutment for the liquid in the form of a coned flange *c*, against which the film of liquid is thus projected,

whereby it is pulverized. The diameter of the post *b* may be reduced without affecting the action of the atomizer. In order to still further increase the fineness of the spray produced, air or gas may be introduced into the box along with the liquid either by the same or a separate pipe. The conical head *h* above the flange *c* is to facilitate the placing of the diaphragm *d* in position.

It will be understood that the form, dimensions, and details of the apparatus may be varied without departing from the invention.

This liquid atomizer or pulverizer may be used wherever it is desired to atomize a liquid—for example, for the treatment of plants, for moistening the air in factories, or for intimately mixing or treating certain liquids or materials, and in medicine or hygiene for pulverizing antiseptic, disinfecting, or other liquids—and it may be combined with any kind of pumps or compressing apparatus and appliances for forcing liquids.

I claim—

1. The herein-described liquid atomizer or pulverizer, consisting in the combination of a chamber having an inlet, with an apertured flexible diaphragm traversing said chamber, and with a post traversing the aperture in said diaphragm, substantially as herein shown and described.

2. The herein-described liquid atomizer or pulverizer, consisting in the combination of a chamber having an inlet, with an apertured flexible diaphragm, and with a post traversing the aperture in said diaphragm, said post having an abutment or projecting surface presented in the path of the film of liquid forced between the diaphragm and post, substantially as specified.

The foregoing specification of my liquid atomizer or pulverizer signed by me this 14th day of April, 1891.

FRANÇOIS FERNAND BOURDIL.

Witnesses:

ROBT. M. HOOPER,
ALBERT MOREAU.