

(No Model.)

A. P. QUIGLEY.

WRENCH.

No. 341,503.

Patented May 11, 1886.

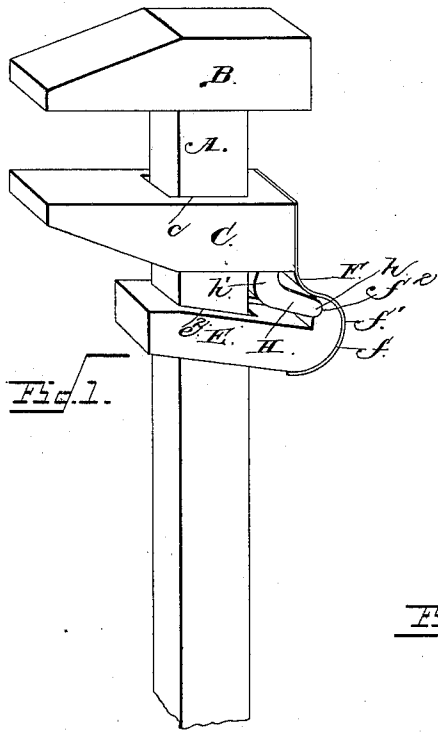

Fig. 1.

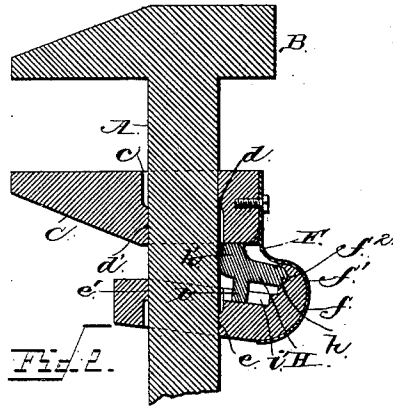

Fig. 2.

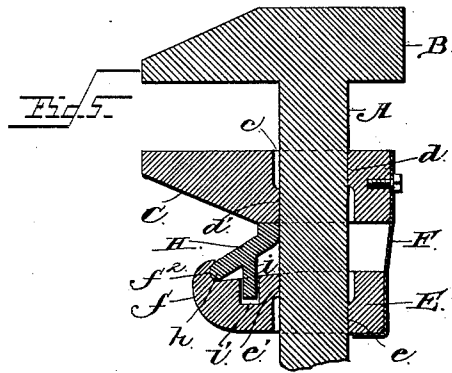

Fig. 5.

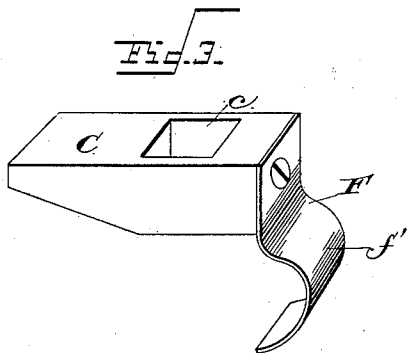

Fig. 3.

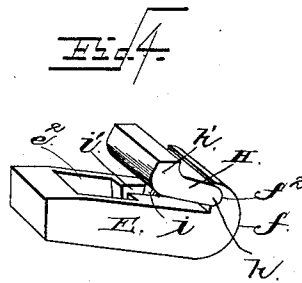

Fig. 4.

Witnesses
M. C. Fowler
H. A. Berwick

Inventor
A. P. Quigley
By *his* Attorneys
C. A. Snowden

UNITED STATES PATENT OFFICE.

ANDREW PATRICK QUIGLEY, OF JAMESTOWN, NEW YORK, ASSIGNOR OF
ONE-HALF TO JAMES L. WEEKS, OF SAME PLACE.

WRENCH.

SPECIFICATION forming part of Letters Patent No. 341,503, dated May 11, 1886.

Application filed March 6, 1886. Serial No. 194,394. (No model.)

To all whom it may concern:

Be it known that I, ANDREW PATRICK QUIGLEY, a citizen of the United States, residing at Jamestown, in the county of Chautauqua and State of New York, have invented new and useful Improvements in Monkey-Wrenches, of which the following is a specification, reference being had to the accompanying drawings.

My invention relates to improvements in monkey-wrenches; and it consists in the peculiar and novel construction and combination of parts, substantially as hereinafter fully set forth, and specifically pointed out in the claims.

The primary object of my invention is to provide an improved monkey-wrench with an adjustable or movable jaw which can be moved very rapidly and easily on the handle-bar, and which shall be held firmly and rigidly thereon without danger of becoming displaced or retrograde movement after the jaw has been once adjusted to a nut or other class of work.

A further object of the invention is to provide an improved wrench that will open to double the capacity of an ordinary monkey or screw wrench of the same size, and thus adapt a single wrench to a wider range of uses, while at the same time the cost of manufacture and sale of my improved device is reduced to a minimum.

The improved device is very simple, strong, and durable in its construction, thoroughly effective and reliable in its operation, easy and quick of adjustment, and cheap of manufacture.

In the accompanying drawings, Figure 1 is a perspective view of a wrench constructed in accordance with my invention. Fig. 2 is a vertical central longitudinal sectional view thereof. Fig. 3 is a detail perspective view of the adjustable or movable jaw detached from the handle-bar. Fig. 4 is a similar view of the binding-sleeve; Fig. 5, a vertical sectional view of a modification of my invention.

Referring to the drawings, in which like letters of reference indicate corresponding parts in all the figures, A designates the handle-bar of my improved wrench, which is made, preferably, square or rectangular in cross-section, as is usual; and B, the rigid jaw, permanently

affixed to or cast with the handle-bar at the upper free end thereof.

C designates the movable jaw, that corresponds in shape to the rigid jaw B, both of which are of the common well-known or any preferred forms. The movable jaw C has an opening, *c*, therein, that corresponds to the shape of, and is a little larger in one direction than, the shape and size of the handle-bar A in cross-section. The movable jaw is free to slide on the handle-bar longitudinally thereof, and on the inner faces of the walls of the opening *c*, which are a farther distance apart than one of the transverse diameters of the bar A. The movable jaw has shoulders *d d'* formed thereon, which are of a depth equal to or a little greater than one-half of the depth of the opening, these shoulders being arranged on opposite sides and edges—that is to say, the shoulder *d* is on the upper edge and one side of the opening, while the shoulder *d'* is on the opposite side and lower edge of said opening.

E designates a binding-sleeve fitted on the bar beneath the movable jaw, and also having an opening, *e*, to fit the bar, two of the inner faces of the opening having shoulders *e e'*, similar to the shoulders *d d'*, but reversed in their relative positions to each other, as shown more clearly in Fig. 2 of the drawings—that is to say, the shoulder *e*, that lies and bears on the same side of the bar as the shoulder *d*, is arranged at the lower edge of the sleeve E, and the shoulder *e'*, which bears against the bar on the same side as the shoulder *d'*, is arranged at the upper edge of the sleeve E.

F designates a pressure-spring, which is rigidly connected to the jaw C by means of a screw or other suitable means, and bears against a curved end or face of the binding-sleeve. The rear end of the binding-sleeve is curved, as at *f*, to present a broad bearing-surface for the outwardly and rearwardly curved end, *f'*, of the pressure-spring, and the inner face of the extended end *g* of the sleeve is curved or hollowed out to provide a socket or bearing, *f²*, for the lower curved end, *h*, of a brace-plate or detent, H, which is curved upwardly, as at *h'*, and bears against the lower under side of the rear end of the movable jaw and against the rear face of the bar A. This brace-plate is inclosed within and protected

from injury by the movable jaw, the sleeve, and spring, and on its lower face the brace-plate has a stud, *i*, that fits loosely in a socket, *i'*, of the binding-sleeve E, to prevent accidental displacement thereof.

The pressure-spring F serves to cause the projecting shoulders or faces *d d' e e'* to bite or bind on the front and rear faces of the handle-bar, so that the sleeve and movable jaw will be held rigidly and immovably on the bar. A space or chamber is left between the handle-bar and the remaining depth of the inner faces of the jaw and sleeve not occupied by the shoulders thereon, so that the shoulders can be thrown out of engagement with the bar by a slight upward pressure on either the free or outer end of the sleeve or movable jaw, which pressure will be sufficient to overcome the resistance of the spring, and will be transmitted thereby to either the jaw or sleeve which the hand of the operator does not act upon. Thus, if pressure by hand is exerted on the outer end of the movable jaw, the spring will be caused to release its tension on the sleeve, and will serve to release the shoulders *e e'* from engagement with the handle-bar, and vice versa. It will thus be seen that the movable jaw can be rapidly moved to any desired adjustment on the handle-bar to open the jaws to the necessary extent by simply pressing on either the movable jaw and sliding them along the handle-bar, and that they instantaneously re-engage the bar when the hand-pressure thereon is released.

When the jaws have been fitted to a nut or other piece of work and the handle is turned to operate on the work, the strain or force will be brought onto the outer end of the movable jaw, so that its shoulders will be forced into more close and intimate engagement or contact with the handle-bar, and the greater the force exerted on the jaw the firmer will the shoulders' bite on the bar, thus holding the jaw rigid and immovable in place. The lateral strain on the jaw will be transmitted in a measure to the brace plate or detent H, and thus to the binding-sleeve, which will likewise be more firmly and securely held on the bar, and thus serve to brace and very materially strengthen the device.

In the modification shown in Fig. 5 of the drawings the bearing or socket *f²* and the brace-plate or detent H are arranged at the outer end of the binding-sleeve, and the plate bears against the front end of the movable jaw, the operation of this form of my invention being substantially the same as that hereinbefore described, and which will be readily understood.

From the foregoing description, taken in connection with the accompanying drawings, it will be seen that I provide a wrench that is

very simple, strong, and durable in its construction, which can be adjusted with great ease and in a minimum of time, which is very cheap and inexpensive to manufacture, and thoroughly effective and reliable in its operation.

My improved wrench entirely dispenses with the use of an adjusting-screw, which is expensive to manufacture, is liable to soon wear out or become broken, and requires time and labor to adjust the same. The improved wrench can be used advantageously on bridge, railroad, and other heavy work, and will answer the same purpose as a key-wrench.

I do not desire to limit myself to the particular construction and form and proportion of parts herein shown and described as an embodiment of my invention, as I am aware that many changes therein can be made without departing from the spirit of my invention or the advantages thereof.

Having thus fully described my invention, what I claim as new, and desire to secure by Letters Patent, is—

1. In a wrench, the combination of a bar, a rigid jaw, a movable jaw having binding-shoulders at opposite edges with an intermediate space, a binding-sleeve having similarly-disposed shoulders, and a pressure spring connecting the movable jaw and sleeve to adapt them for simultaneous adjustment and normally hold the shoulders thereof in contact with the bar, substantially as described.

2. The combination of a bar having a rigid jaw, the movable jaw, a binding-sleeve, a spring, and a brace or detent fitted between the movable jaw and sleeve, substantially as described.

3. The combination of a bar having a rigid jaw, a movable jaw, a binding-sleeve, a pressure-spring connecting the movable jaw and binding-sleeve, and a brace or detent fitted between and carried by the movable jaw and binding-sleeve and bearing against the bar, substantially as described.

4. In a wrench, the combination of a bar having a rigid jaw, a movable jaw having the binding-shoulders *d d'*, a sleeve having the shoulders *e e'*, a pressure-spring carried by the movable jaw and bearing on the sleeve, and a brace or detent, H, fitted between the movable jaw and sleeve, and having a stud, *i*, fitted to the sleeve, substantially as described.

In testimony that I claim the foregoing as my own I have hereto affixed my signature in presence of two witnesses.

ANDREW PATRICK QUIGLEY.

Witnesses:

EDWARD R. BOOTSY,
JAMES J. TOWLER.